



401-17.11.EN

***API Maxum OH2 –  
End Suction Process Pump***

**Technical Specification Pages**

This page left intentionally blank.

**1.0 Overview.**

The API Maxum OH2 is our heavy duty process pump for handling hydrocarbons in refining and process industry applications. It is offered as a centerline mounted unit. Hydraulic performance extends to 11,500 GPM and 720 feet of head.

**1.1 Basic Design Features**

Basic design features for the API Maxum OH2 are given in the table below.

<b>Basic Design Features</b>									
Pump Size	Bearing Frame	Max Speed (RPM)	1 <sup>st</sup> Critical Speed (RPM)	Casing Design		Shaft Deflection @ 20% BEP		Shaft Stiffness L <sup>3</sup> /D <sup>4</sup>	WK <sup>2</sup> @ Max. Impeller Dia.
				Discharge	Volute(s)	@ Seal (in.)	@ Impeller (in.)		
AA- 1½ x 1 x 6	3	3500	13068	Centerline	Single	0.0002	0.0009	183.3	9.500
AB - 2 x 1½ x 6	3	3500	12098	Centerline	Single	0.0006	0.0019	183.3	10.45
AC- 3 x 1½ x 6	3	3500	11317	Centerline	Single	0.0006	0.0021	183.3	11.40
AD - 3 x 2 x 6	3	3500	12098	Centerline	Single	0.0011	0.0036	183.3	10.45
AE - 4 x 3 x 6	3	3500	10122	Centerline	Dual	0.0021	0.0070	183.3	15.20
BA - 1½ x 1 x 8	4	3500	12262	Centerline	Single	0.0003	0.0011	83.6	34.31
BB - 2 x 1½ x 8	4	3500	10754	Centerline	Single	0.0005	0.0017	83.6	41.42
BC - 3 x 1½ x 8	4	3500	11193	Centerline	Single	0.0006	0.0022	83.6	39.05
BD - 3 x 2 x 8	4	3500	11193	Centerline	Single	0.0008	0.0029	83.6	39.05
BE - 4 x 3 x 8	4	3500	10363	Centerline	Dual	0.0004	0.0014	83.6	43.79
BF - 6 x 4 x 8	4	3500	10012	Centerline	Dual	0.0005	0.0017	83.6	46.16
CA - 2 x 1½ x 10	5	3500	13192	Centerline	Single	0.0002	0.0012	42.3	92.29
CB - 3 x 1½ x 10	5	3500	13192	Centerline	Single	0.0002	0.0011	42.3	92.29
CC - 3 x 2 x 10	5	3500	12773	Centerline	Single	0.0004	0.0022	42.3	92.29
CD - 4 x 3 x 10	5	3500	12042	Centerline	Quad	0.0006	0.0032	42.3	108.6
CE - 6 x 4 x 10	5	3500	10429	Centerline	Dual	0.0002	0.0012	42.3	141.3
CF - 6 x 6 x 10	5	1750	8288	Centerline	Dual	0.0002	0.0010	42.3	141.3
CG - 8 x 6 x 10	5	1750	10020	Centerline	Dual	0.0002	0.0012	42.3	152.2
DA - 2 x 1½ x 13	6	3500	11224	Centerline	Single	0.0003	0.0019	35.0	209.6
DB - 3 x 2 x 13	6	3500	8511	Centerline	Single	0.0005	0.0026	35.0	201.8
DC - 4 x 3 x 13	6	3500	9515	Centerline	Quad	0.0009	0.0054	35.0	263.8
DD - 6 x 4 x 13	6	3500	9098	Centerline	Dual	0.0002	0.0013	35.0	287.1
DE - 6 x 6 x 13	6	1750	8306	Centerline	Dual	0.0002	0.0010	35.0	310.3
DF - 8 x 6 x 13	6	1750	7130	Centerline	Dual	0.0003	0.0016	35.0	310.3
DG - 10 x 8 x 13	6	1750	6728	Centerline	Dual	0.0004	0.0023	35.0	418.9
DH - 12 x 10 x 13	6	1750	6215	Centerline	Dual	0.0008	0.0043	35.0	418.9
ED- 6 x 4 x 16	8	1750	8223	Centerline	Dual	0.0001	0.0005	19.5	563.6
EA- 8 x 6 x 16	8	1750	7885	Centerline	Dual	0.0001	0.0011	19.5	647.3
EB - 10 x 8 x 16	8	1750	9053	Centerline	Dual	0.0001	0.0012	19.5	595.9
EE - 12 x 10 x 16	8	1750	7840	Centerline	Dual	0.0001	0.0006	19.5	722.6
EC - 14 x 12 x 16	8	1750	7752	Centerline	Dual	0.0004	0.0035	19.5	849.4
FA - 8 x 6 x 20	8	1750	7478	Centerline	Dual	0.0001	0.0012	19.5	1232.0
FB - 10 x 8 x 20	8	1750	7288	Centerline	Dual	0.0002	0.0018	19.5	1495.0
FC - 12 x 10 x 20	8	1750	6714	Centerline	Dual	0.0003	0.0026	19.5	1859.0
FD - 14 x 12 x 20	8	1750	6075	Centerline	Dual	0.0005	0.0039	19.5	2298.0

**1.2 Standard Surface Treatment**

All API Maxum OH2 Pumps handling liquids below 230 °F are painted to Carver Standard PA-007. This provides for one coat of Carver Blue, modified epoxy phenalkamine with a 4-6 mils dry film thickness. Pumps handling liquids above 230 °F are painted to Carver Standard PA-013 with two coats modified silicone alkyd resin, aluminum colored, to a total of 2 mils dry film thickness.

Since all pumps and parts are assumed to be installed and operated soon after receipt, no special preservation for long term storage are included, contact factory for long term storage.

<b>Standard Surface Preparation</b>		
Component	Material	Specification
Base	Steel - Top	Carver Standard PA-007-02
	Base Grout Area	Carver Standard PA-014
	Stainless Steel	Not applicable
Guards	316 SS	N/A
	Steel	Safety Yellow
Bearing frame	Steel	Carver Standard PA-007-02 or PA-013 (High Temp)
Casing	Steel	Carver Standard PA-007-02 or PA-013 (High Temp)
	Stainless Steel	Not applicable
Motor	Any	Manufactures Standard

**1.3 Basic Impeller Design Features**

Standard impeller design features for the API Maxum OH2 are given in the table below. All standard impellers are of the enclosed type with back wear rings for axial thrust control.

Basic Impeller Design Features										
Basic Pump Size	Type	Axial Thrust Back Design	Eye Area (inch) <sup>2</sup>	No. of Vanes	Shut Off Head (ft)	Specific Speed Ns	Suction Sp. Speed Nss	Max. Solids Size (inch)	Wear Ring Clearance (inch) Front Rear	
AA- 1½ x 1 x 6	Enclosed	Wear ring	2.4	4	120	1071	6907	0.23	0.012	0.012
AB - 2 x 1½ x 6	Enclosed	Wear ring	3.8	4	160	1337	14044	0.31	0.015	0.015
AC- 3 x 1½ x 6	Enclosed	Wear ring	5.1	5	158	1250	7446	0.38	0.014	0.014
AD - 3 x 2 x 6	Enclosed	Wear ring	8.2	6	190	1455	11644	0.50	0.016	0.016
AE - 4 x 3 x 6	Enclosed	Wear ring	12.0	8	171	2279	8516	0.88	0.016	0.016
BA - 1½ x 1 x 8	Enclosed	Wear ring	2.1	4	270	578	5183	0.14	0.012	0.012
BB - 2 x 1½ x 8	Enclosed	Wear ring	3.6	4	285	690	6423	0.19	0.012	0.012
BC - 3 x 1½ x 8	Enclosed	Wear ring	5.5	5	292	807	9761	0.25	0.014	0.014
BD - 3 x 2 x 8	Enclosed	Wear ring	8.0	5	285	952	7361	0.38	0.016	0.016
BE - 4 x 3 x 8	Enclosed	Wear ring	15.8	7	290	1746	10135	0.75	0.017	0.017
BF - 6 x 4 x 8	Enclosed	Wear ring	18.0	8	290	2111	11683	1.13	0.017	0.017
CA - 2 x 1½ x 10	Enclosed	Wear ring	3.3	6	475	413	4793	0.19	0.012	0.012
CB - 3 x 1½ x 10	Enclosed	Wear ring	5.9	5	420	413	9939	0.30	0.015	0.015
CC - 3 x 2 x 10	Enclosed	Wear ring	8.6	6	470	663	7887	0.38	0.016	0.016
CD - 4 x 3 x 10	Enclosed	Wear ring	16.0	7	465	668	11824	0.63	0.017	0.017
CE - 6 x 4 x 10	Enclosed	Wear ring	21.5	7	450	1117	11547	0.88	0.018	0.018
CF - 6 x 6 x 10	Enclosed	Wear ring	24.7	5	115	1960	7180	1.00	0.018	0.018
CG - 8 x 6 x 10	Enclosed	Wear ring	39.0	6	103	2828	10204	1.50	0.019	0.019
DA - 2 x 1½ x 13	Enclosed	Wear ring	5.2	6	730	329	5624	0.31	0.016	0.016
DB - 3 x 2 x 13	Enclosed	Wear ring	8.6	6	705	480	11296	0.38	0.016	0.016
DC - 4 x 3 x 13	Enclosed	Wear ring	18.2	7	670	855	11080	0.25	0.019	0.019
DD - 6 x 4 x 13	Enclosed	Wear ring	21.5	7	710	912	10500	0.69	0.018	0.018
DE - 6 x 6 x 13	Enclosed	Wear ring	28.6	7	167	1350	7475	0.88	0.018	0.018
DF - 8 x 6 x 13	Enclosed	Wear ring	44.0	8	172	1771	10595	1.44	0.020	0.020
DG - 10 x 8 x 13	Enclosed	Wear ring	60.0	7	160	2466	13029	1.88	0.021	0.021
DH - 12 x 10 x 13	Enclosed	Wear ring	89.0	6	164	3570	12182	2.75	0.023	0.023
ED - 6 x 4 x 16	Enclosed	Wear ring	21.6	6	287	736	7666	0.45	0.018	0.018
EA - 8 x 6 x 16	Enclosed	Wear ring	44.0	7	282	1211	10677	1.00	0.020	0.020
EB - 10 x 8 x 16	Enclosed	Wear ring	60.0	8	265	1477	12794	1.38	0.021	0.020
EE - 12 x 10 x 16	Enclosed	Wear ring	80.7	6	230	2543	14418	0.75	0.024	0.024
EC - 14 x 12 x 16	Enclosed	Wear ring	105.0	7	265	3106	13609	2.50	0.024	0.024
FA - 8 x 6 x 20	Enclosed	Wear ring	43.5	7	425	909	10268	0.75	0.020	0.020
FB - 10 x 8 x 20	Enclosed	Wear ring	61.0	7	435	1092	11449	1.00	0.021	0.021
FC - 12 x 10 x 20	Enclosed	Wear ring	102.0	7	425	1633	13006	1.38	0.023	0.023
FD - 14 x 12 x 20	Enclosed	Wear ring	125.0	7	405	2026	9912	2.00	0.025	0.025

**1.4 Minimum/Maximum Flow Calculation.**

Unless specified otherwise in the characteristic curves or on the data sheets, the following applies:

- Q<sub>min</sub> = 0.1 x Q<sub>opt</sub> for short operation
- Q<sub>min</sub> = 0.3 x Q<sub>opt</sub> for continuous operation
- Q<sub>max</sub> = 1.1 x Q<sub>opt</sub> for 2-pole operation
- Q<sub>max</sub> = 1.25 x Q<sub>opt</sub> for 4-pole operation
- Q<sub>opt</sub> = optimum efficiency

The data above refers to water and water-like liquids. However, if the physical properties of the fluids handled are different from water, the calculation formula below must be used to check if an additional heat build-up may lead to a dangerous temperature increase at the pump surface. If necessary, the minimum flow must be increased.

$$T_o = T_f + \Delta T$$

$$\Delta T = \frac{g * H}{c * \eta} * (1 - \eta)$$

- c Specific heat [J / kg K]
- g Acceleration due to gravity [m/s<sup>2</sup>]
- H Pump head [m]
- T f Temperature of fluid handled [°C]
- T o Temperature of casing surface [°C]
- η Pump efficiency at duty point [-]
- Δ T Temperature difference [°C]

## 1.5 Materials of Construction

Below are the available API Maxum OH2 materials of construction:

Materials of Construction	
Commonly Used Materials	WCB Carbon Steel, 12% Chrome Materials, 316 SS and CD4MCuN Duplex
API Material Codes	S1, S3, S4, S5, S6, S8, S9, A8, C6, D1 and D2
Severe Duty Materials	Hastelloy B, Hastelloy C, 254 SMO, 654 SMO and Titanium

Other materials available, including coatings and composites, to meet specific application requirements.

## 1.6 Key Mechanical Data

Many of the key API Maxum OH2 mechanical design specifications and parameters are as follows:

Key Mechanical Data					
Item	Bearing Frame				
	3	4	5	6	8
Max power (BHP) @ 3500 RPM	150	240	550	550	-
@ 1750 RPM	75	120	275	275	1500
@ 1150 RPM	50	80	180	180	1000
Bearing type - radial bearing	6211	6211	6213	6213	6219
thrust bearing	7311	7311	7313	7313	7318
Lubrication method (standard)	Oil - ISO Grade 68				
L <sub>10</sub> bearing life (hrs) - radial	50,000				
thrust	50,000				
Radial to thrust bearing centerline (in.)	5.992	5.992	8.939	8.939	13.198
Shaft diameter (in.) @ coupling	1.375	1.375	2.000	2.000	3.000
@ impeller hub (standard ext.)	1.000	1.375	1.375	1.875	2.375
@ radial bearing	2.166	2.166	2.559	2.559	3.741
@ thrust bearing	2.166	2.166	2.559	2.559	3.544
@ seal box	1.575	1.968	2.362	2.500	3.543
Coupling Key – width (in.)	0.313	0.313	0.500	0.500	0.750
length (in.)	2.625	2.625	2.000	2.000	5.000
Oil Volume - Cubic Inches	150	150	300	300	500
Gallons	.65	.65	1.3	1.3	2.2

## 1.7 Basic Structural Design Limits

The API Maxum OH2 pumps are design with a standard MAWP of 600 psig (40 bar) at 600 °F. Pressure boundary components are design to ASME section VIII with .125 inch (3mm) corrosion and .125 inch (3mm) core shift allowance. Higher pressure ratings may be available with alternate materials and/or higher level of casting inspection.

### 1.8 Seal Box Dimensions

The API Maxum OH2 is designed for cartridge mechanical seals in accordance with the minimum seal chamber dimensions per API Standard 610.

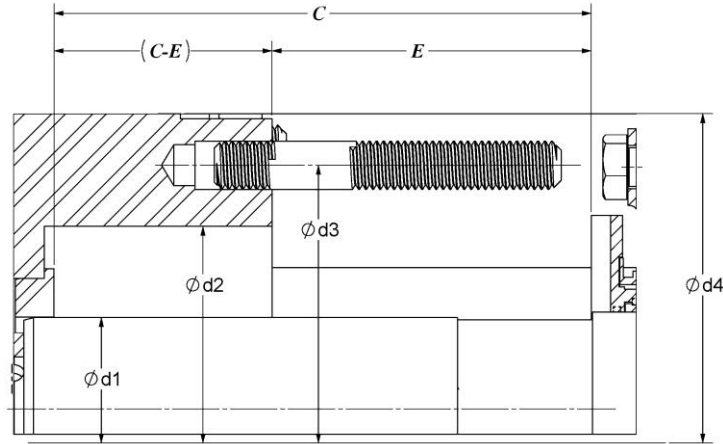

Reference Drawing 255-4000-001

Seal Chamber Dimensions (Inches)									
Bearing Frame Number	Pump Size	Shaft Diameter d1	Box Bore d2	Stud Circle d3	Max Gland Diameter d4	Total Length C	Clear Length E	Box Depth C-E	Stud Size (Qty = 4)
3	6	1.5748/1.5742	3.5430/3.5444	4.921	6.625	6.500	4.000	2.500	1/2"-13UNC
4	8	1.9685/1.9679	3.9370/3.9384	5.512	6.625	6.900	4.400	2.500	5/8"-11UNC
5	10	2.3622/2.3615	4.7244/4.7258	6.300	7.750	6.900	4.400	2.500	5/8"-11UNC
6	13	2.5000/2.4995	5.1181/5.1197	6.693	7.750	6.900	4.400	2.500	5/8"-11UNC
8	16 & 20	3.5433/3.5424	6.2992/6.3008	8.070	10.875	7.290	4.790	2.500	3/4"-10UNC

### 1.9 Bearing and Seal Arrangements

The standard API Maxum OH2 uses single row, duplex, 40° angular contact ball bearings to handle axial thrust loads and a single row, Conrad type bearing for the radial loads.

Both are oil lubricated for more effective lubricant penetration of the bearing internals. The bearings can also be provided with several different lubrication arrangements, including external water cooling for higher temperature applications.

Bearing and Seal Temperature Limits			
Bearing	Cooling	Min	Max
Oil Lube	Air	-20° F	399° F
	1 GPM water flush	400° F	600° F

In the table a cooling water temperature of 80° F is assumed. These temperatures limits must be observed to avoid adversely effecting pump life, permanently degrading the fluid, bringing the pump out of alignment, and/or seizing the pump.

The API Maxum OH2 warranty is based on strict adherence to these limits.

**1.10 API Maxum OH2 Hydraulic Coverage and Performance by Individual Size.**

API Maxum OH2 hydraulic performance extends to 11,500 GPM and 720 feet of head. This range is covered by thirty-five sizes in steel, 12% chrome steel and CD4MCu construction.

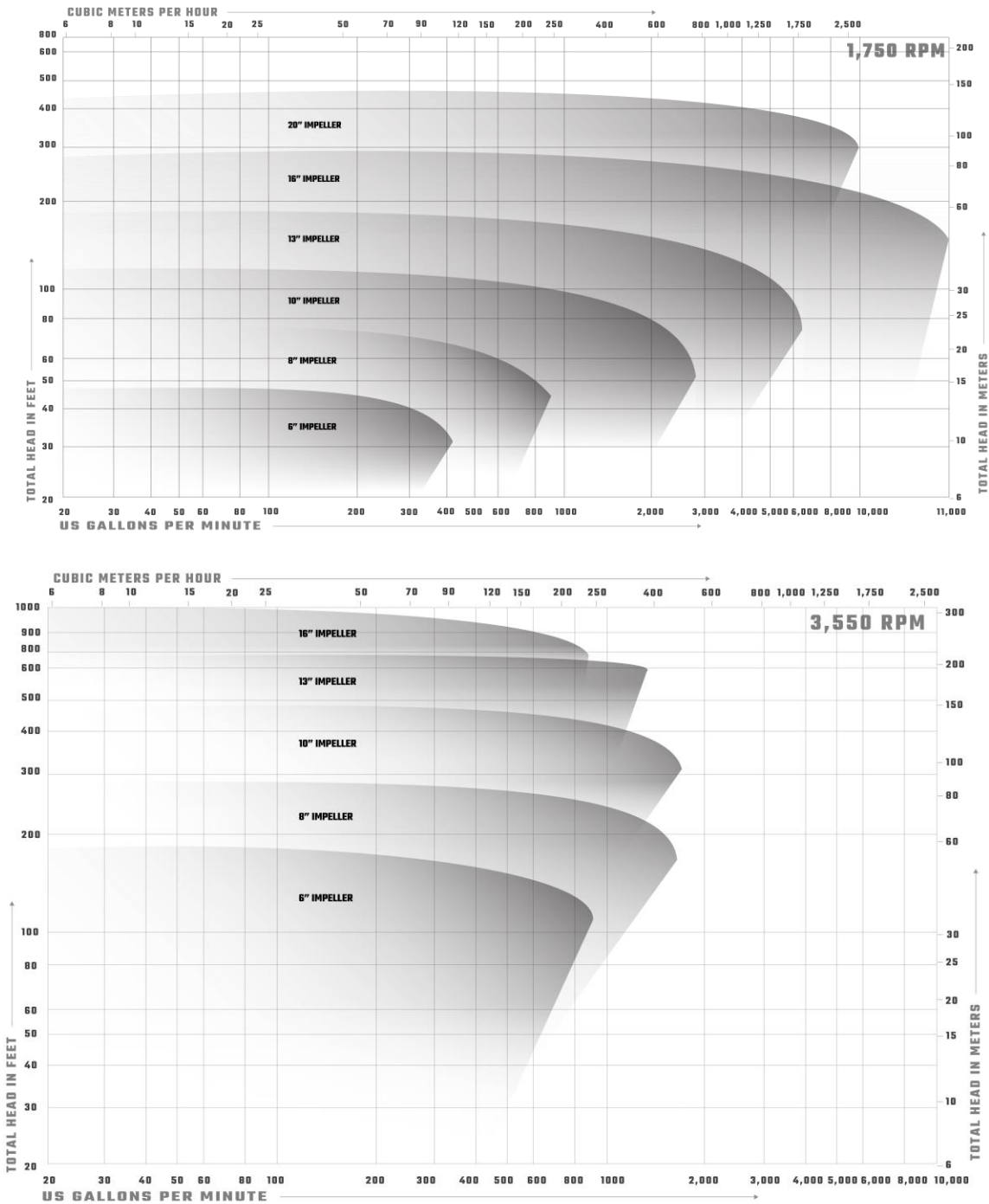

Other sizes and allowable speeds may also be possible. Contact Carver Sales and Marketing department

Hydraulic Performance – 6” Impeller Pumps

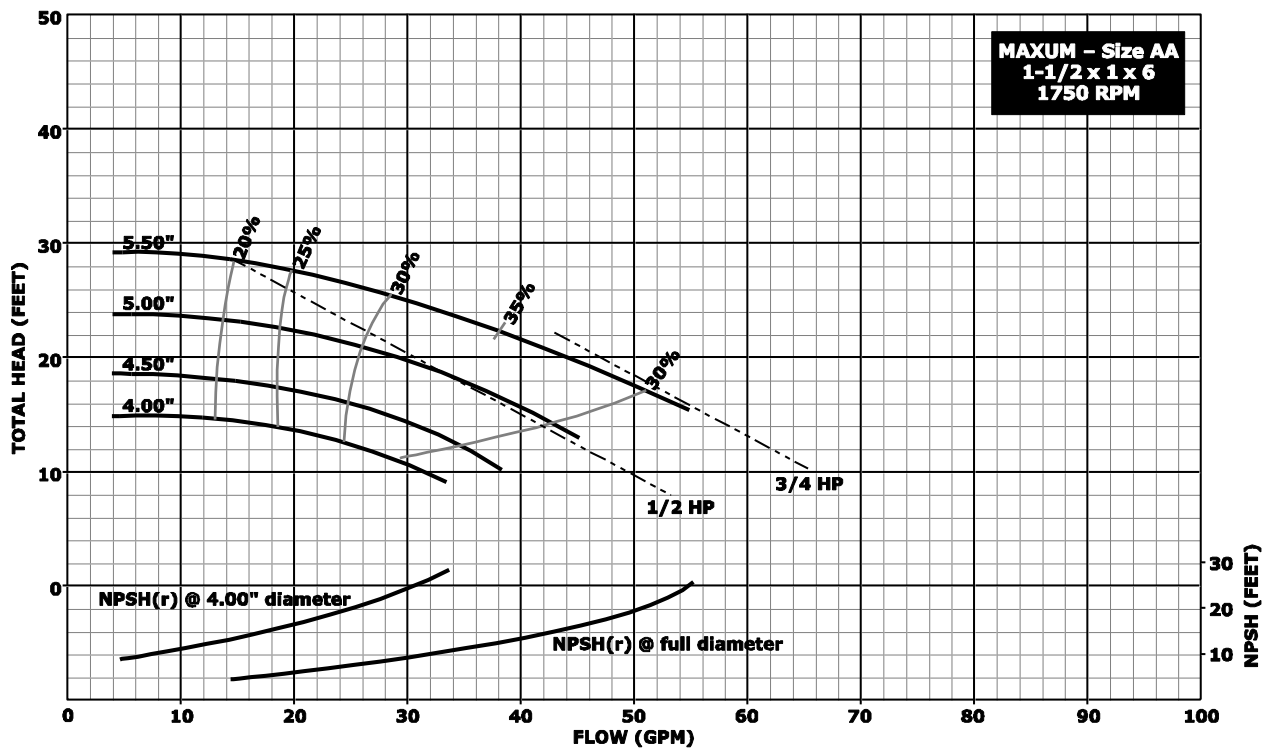
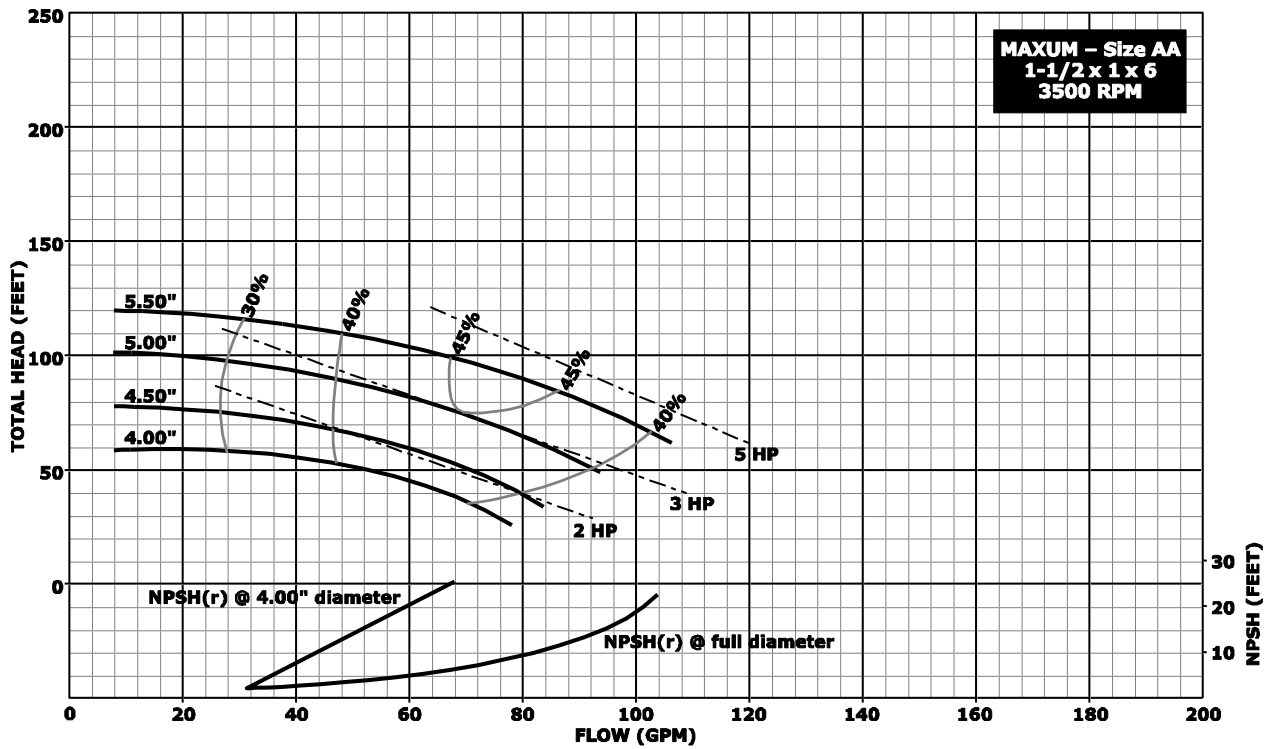

Notes:

1. Above data is based on 1.0 sp. gr. water at ambient temperature and pressure in accordance with Hydraulic Institute guidelines.
2. Impeller diameters between minimum and maximum shown are available in 1/8 inch increment trims.

Hydraulic Performance – 6” Impeller Pumps

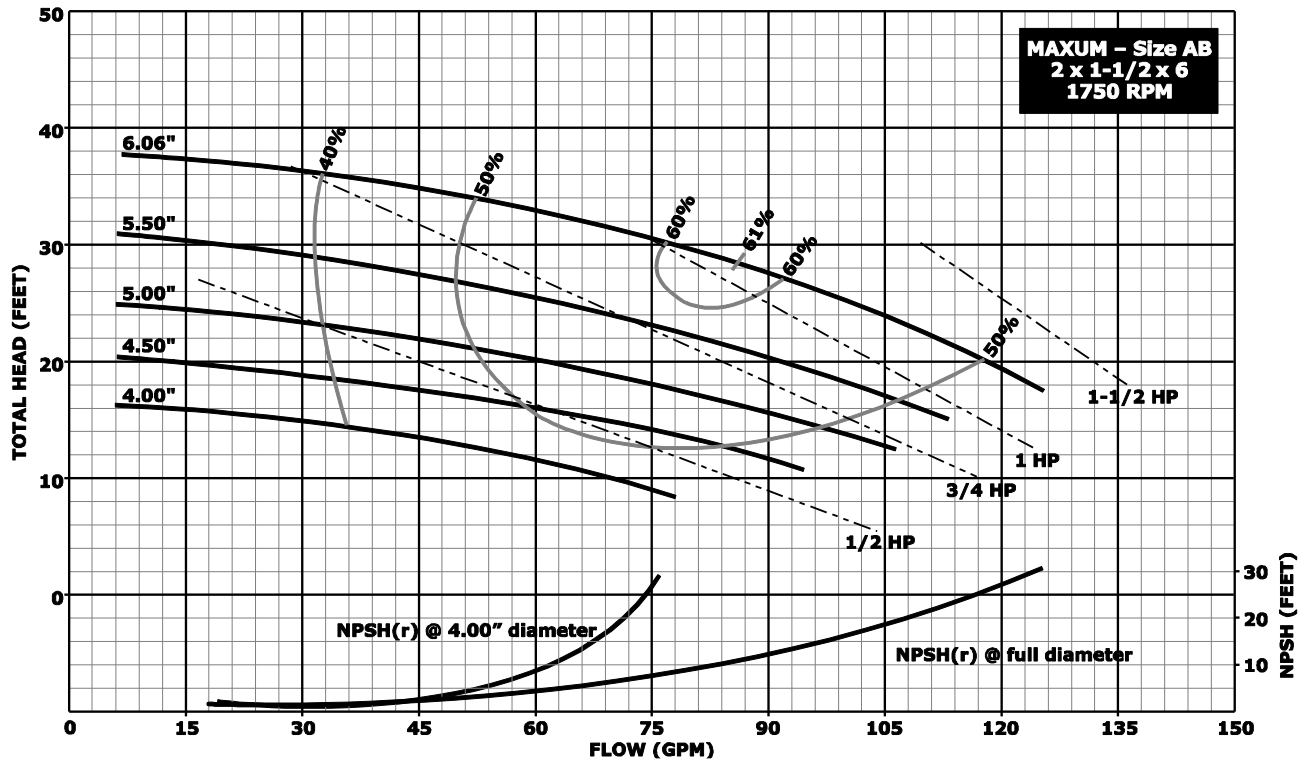
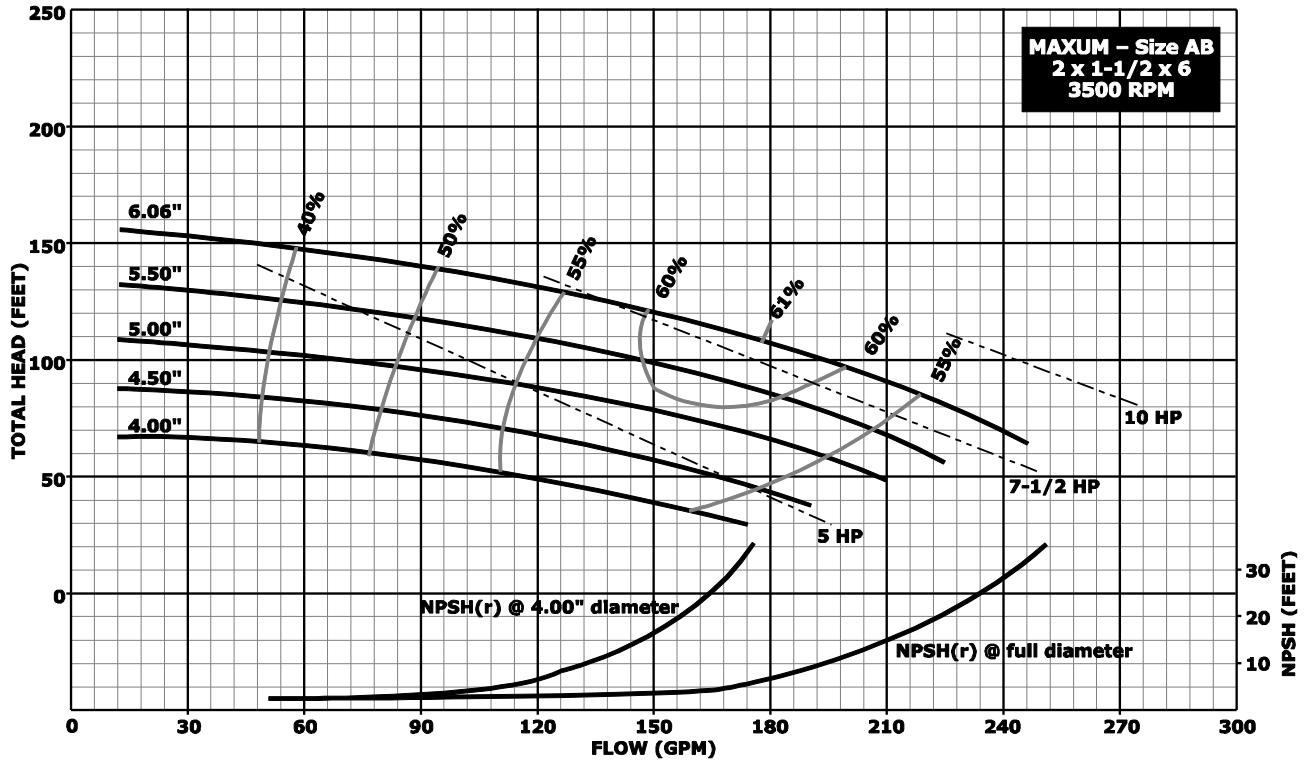

Notes:

1. Above data is based on 1.0 sp. gr. water at ambient temperature and pressure in accordance with Hydraulic Institute guidelines.
2. Impeller diameters between minimum and maximum shown are available in 1/8 inch increment trims.

Hydraulic Performance – 6” Impeller Pumps

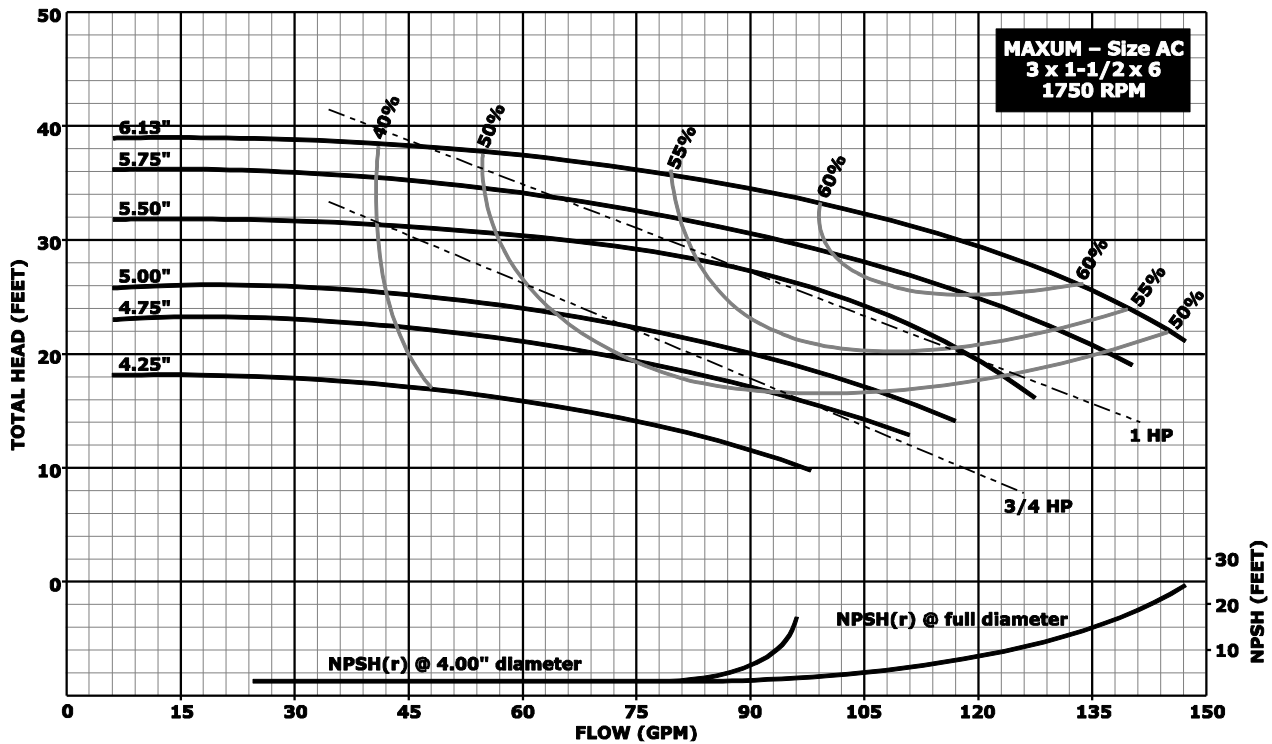
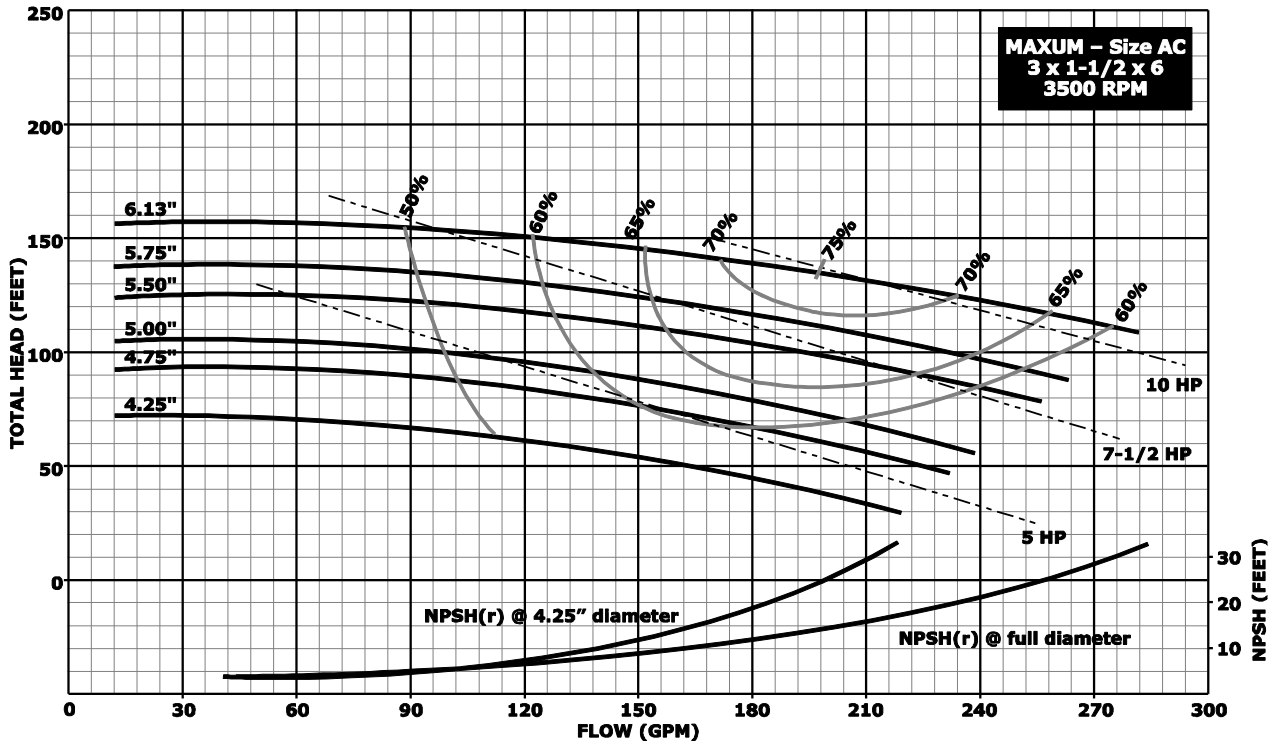

**Notes:**

1. Above data is based on 1.0 sp. gr. water at ambient temperature and pressure in accordance with Hydraulic Institute guidelines.
2. Impeller diameters between minimum and maximum shown are available in 1/8 inch increment trims.

Hydraulic Performance – 6” Impeller Pumps

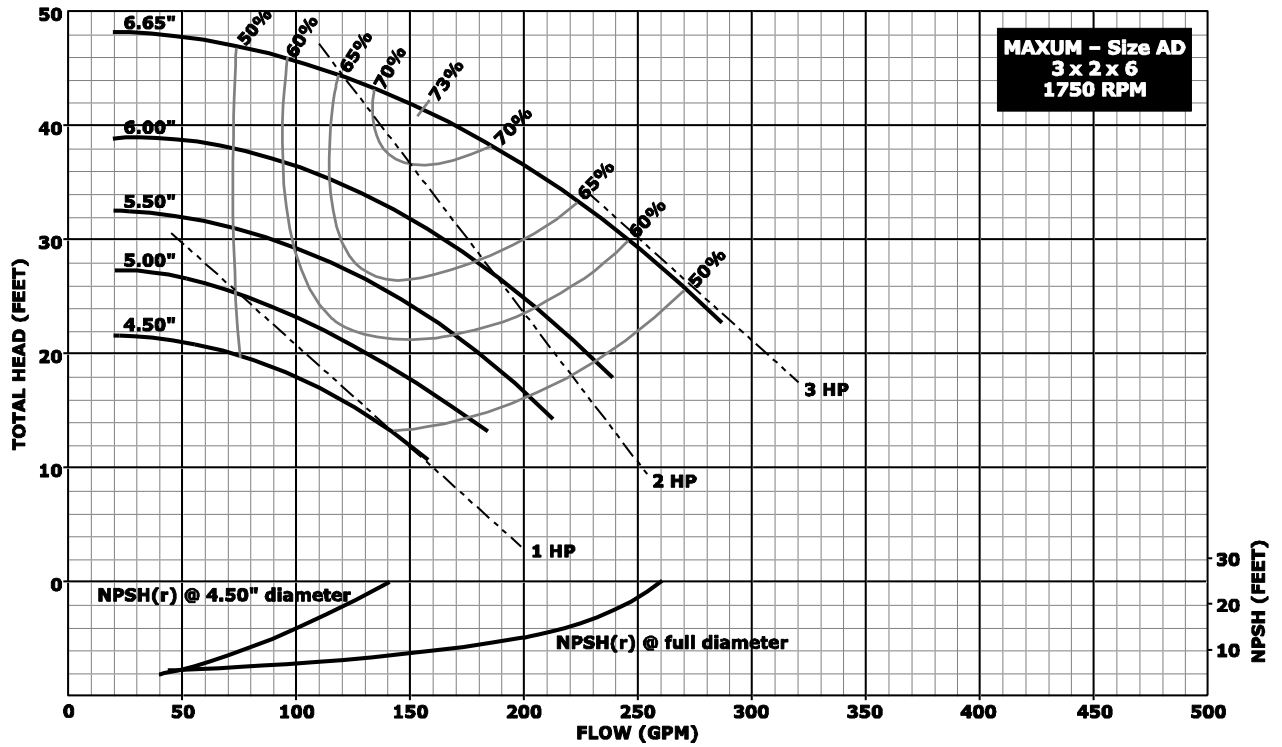
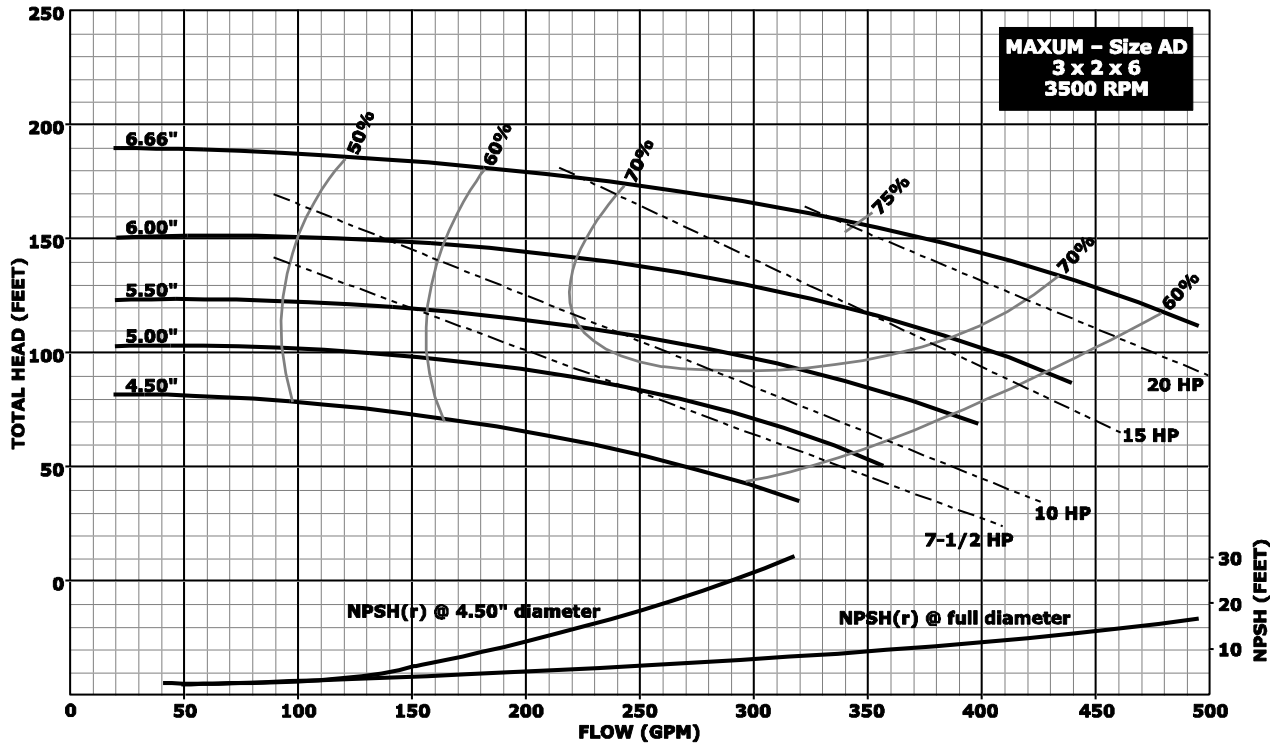

**Notes:**

1. Above data is based on 1.0 sp. gr. water at ambient temperature and pressure in accordance with Hydraulic Institute guidelines.
2. Impeller diameters between minimum and maximum shown are available in 1/8 inch increment trims.

Hydraulic Performance – 6” Impeller Pumps

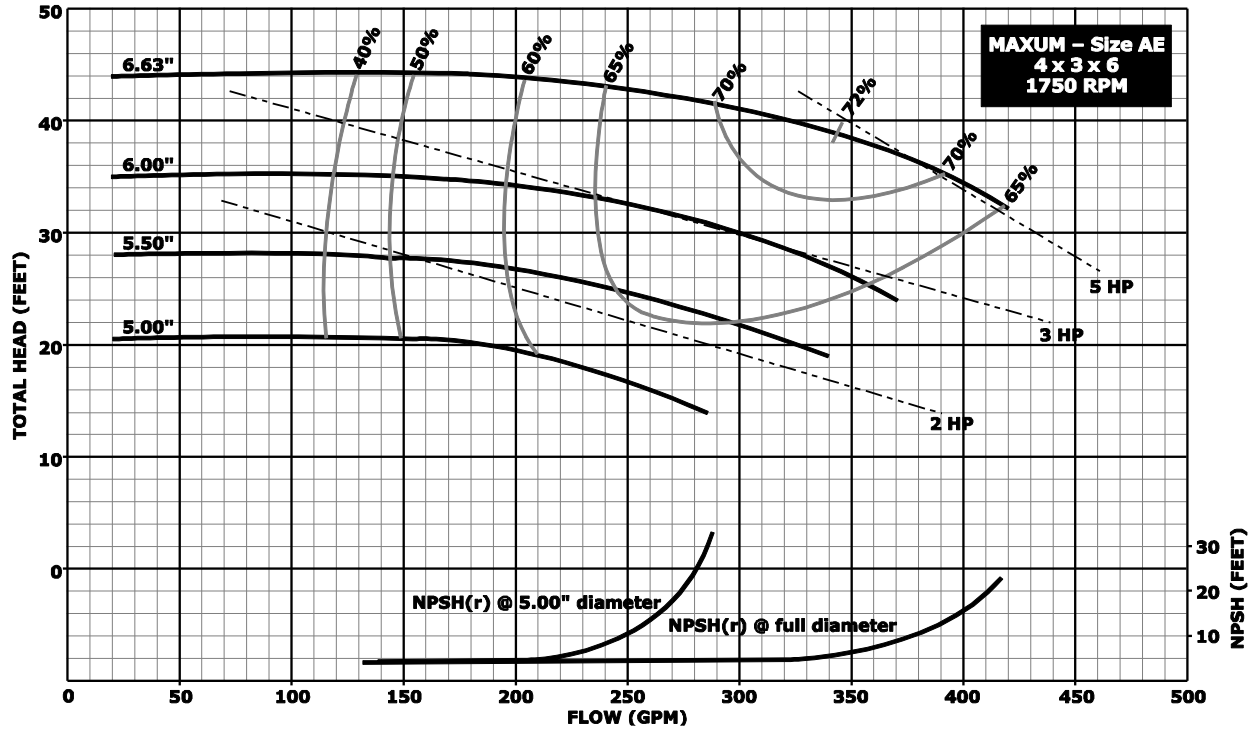
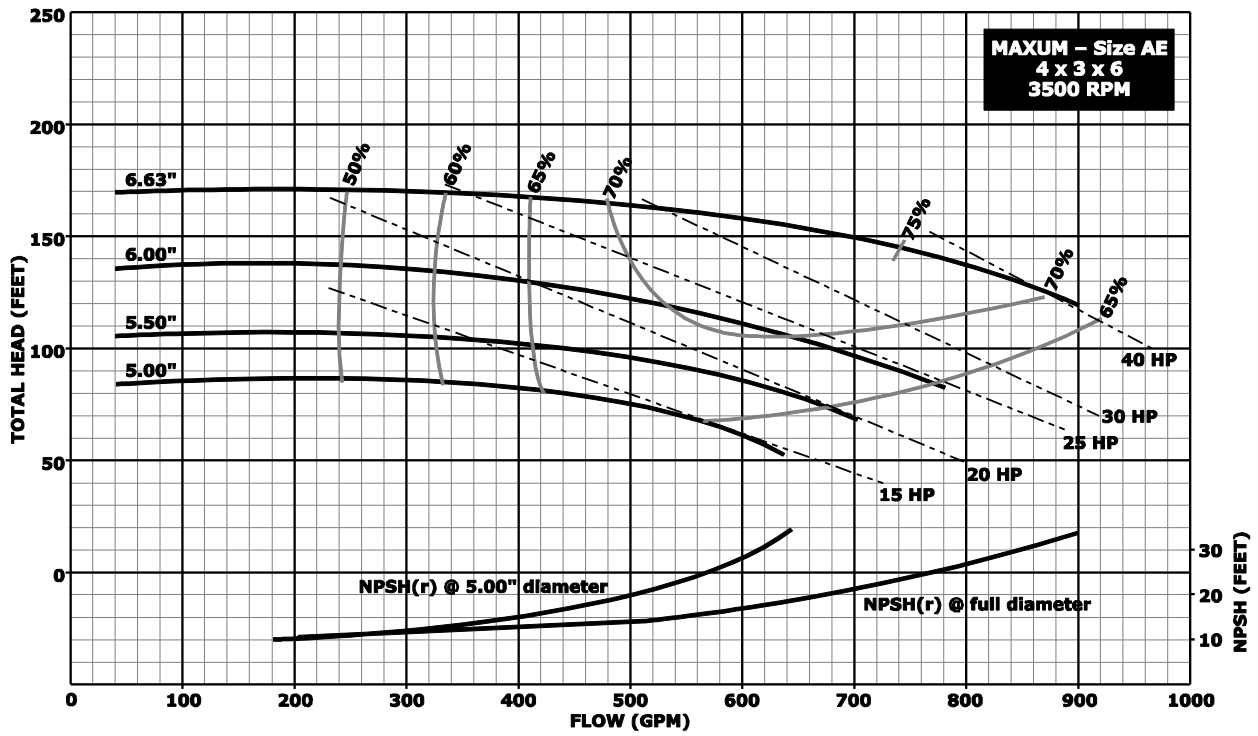

**Notes:**

1. Above data is based on 1.0 sp. gr. water at ambient temperature and pressure in accordance with Hydraulic Institute guidelines.
2. Impeller diameters between minimum and maximum shown are available in 1/8 inch increment trims.

Hydraulic Performance – 8” Impeller Pumps

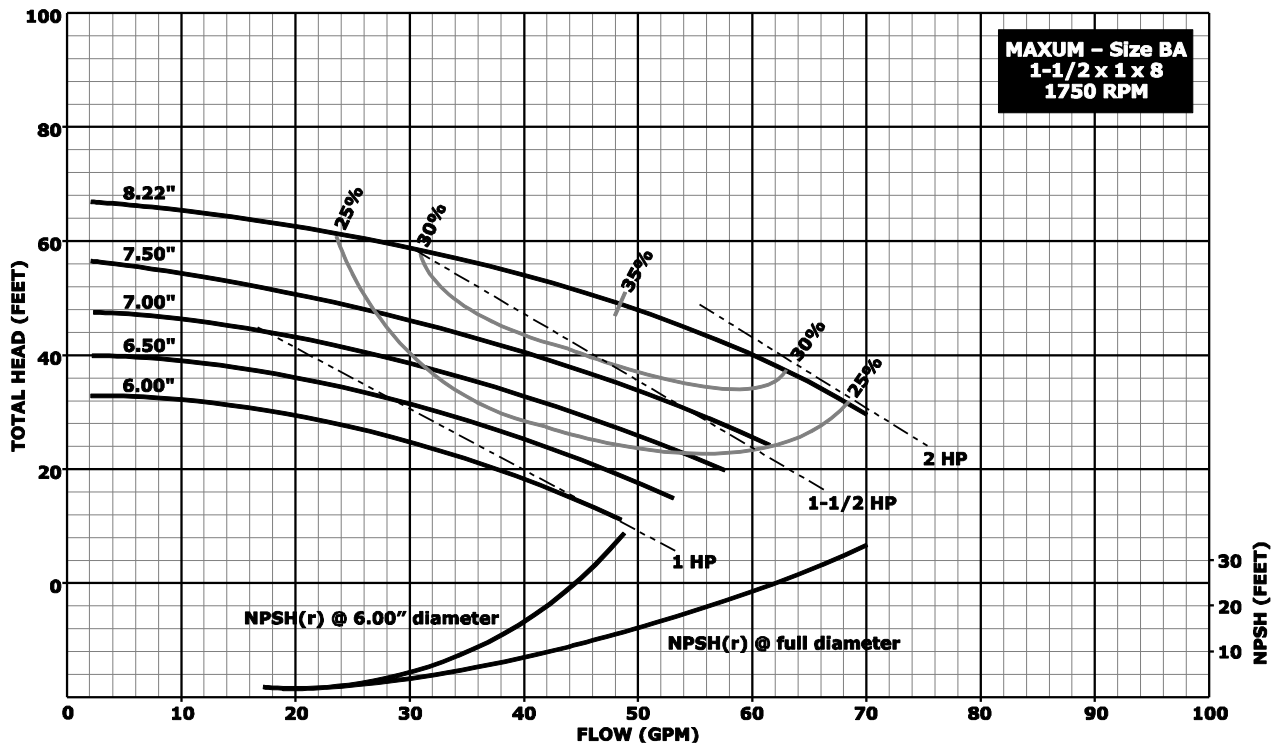
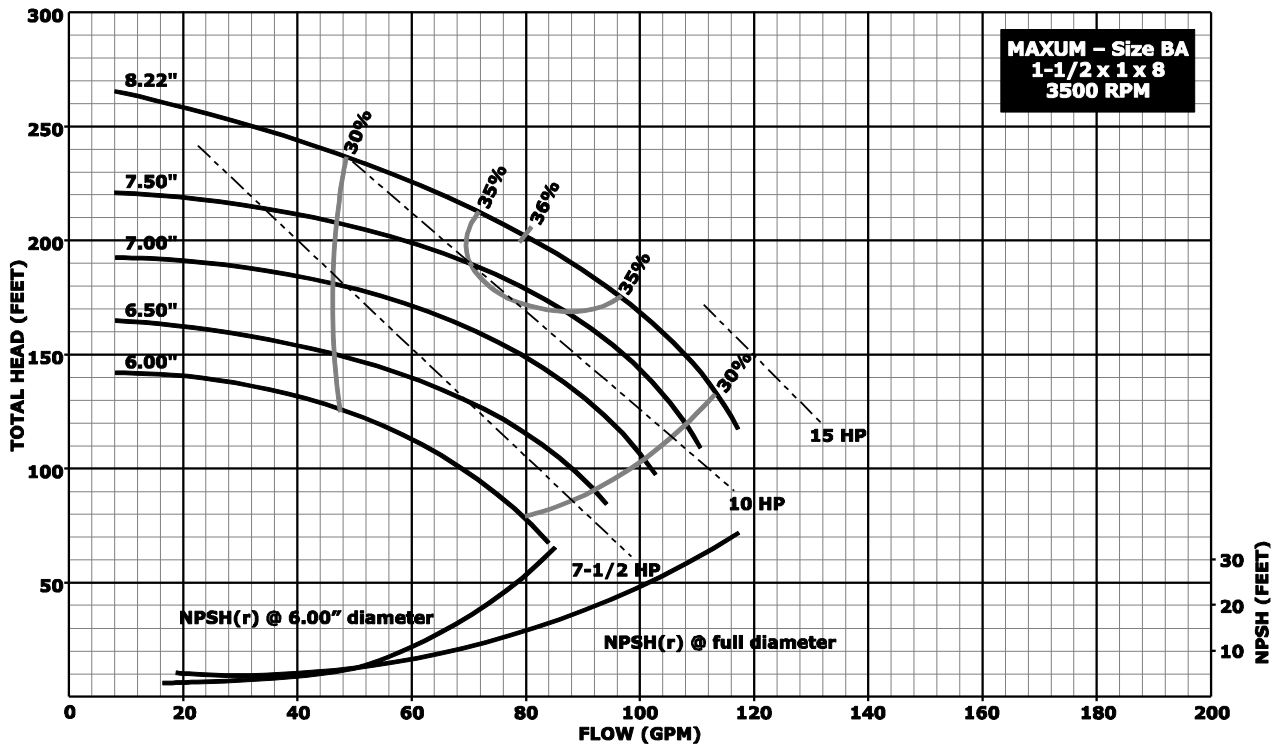

**Notes:**

1. Above data is based on 1.0 sp. gr. water at ambient temperature and pressure in accordance with Hydraulic Institute guidelines.
2. Impeller diameters between minimum and maximum shown are available in 1/8 inch increment trims.

Hydraulic Performance – 8” Impeller Pumps

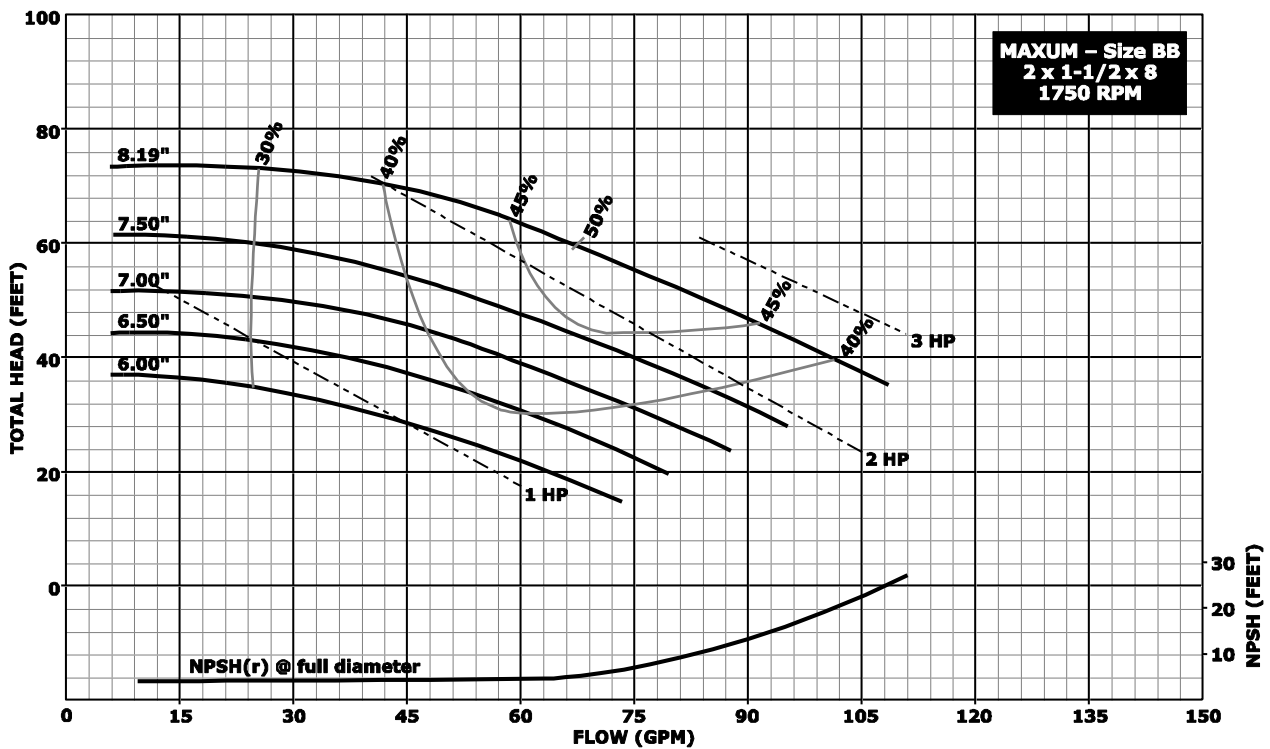
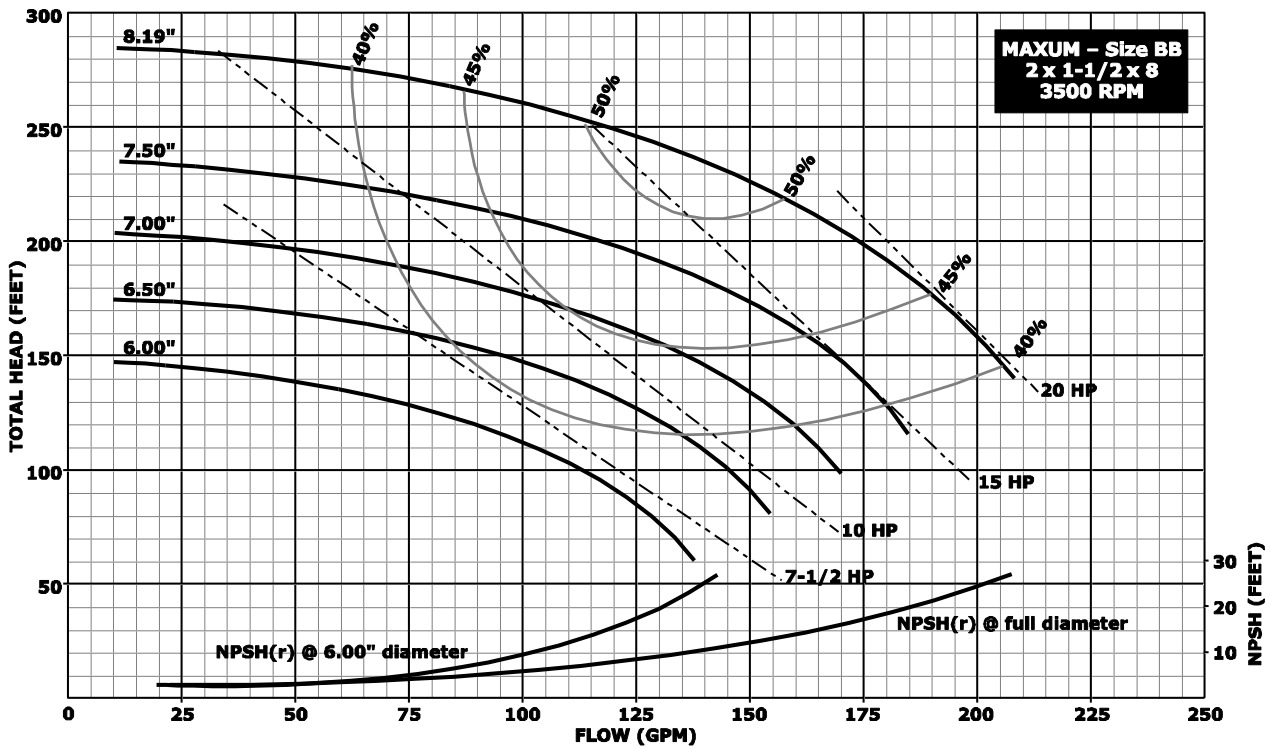

Notes:

1. Above data is based on 1.0 sp. gr. water at ambient temperature and pressure in accordance with Hydraulic Institute guidelines.
2. Impeller diameters between minimum and maximum shown are available in 1/8 inch increment trims.

Hydraulic Performance – 8” Impeller Pumps

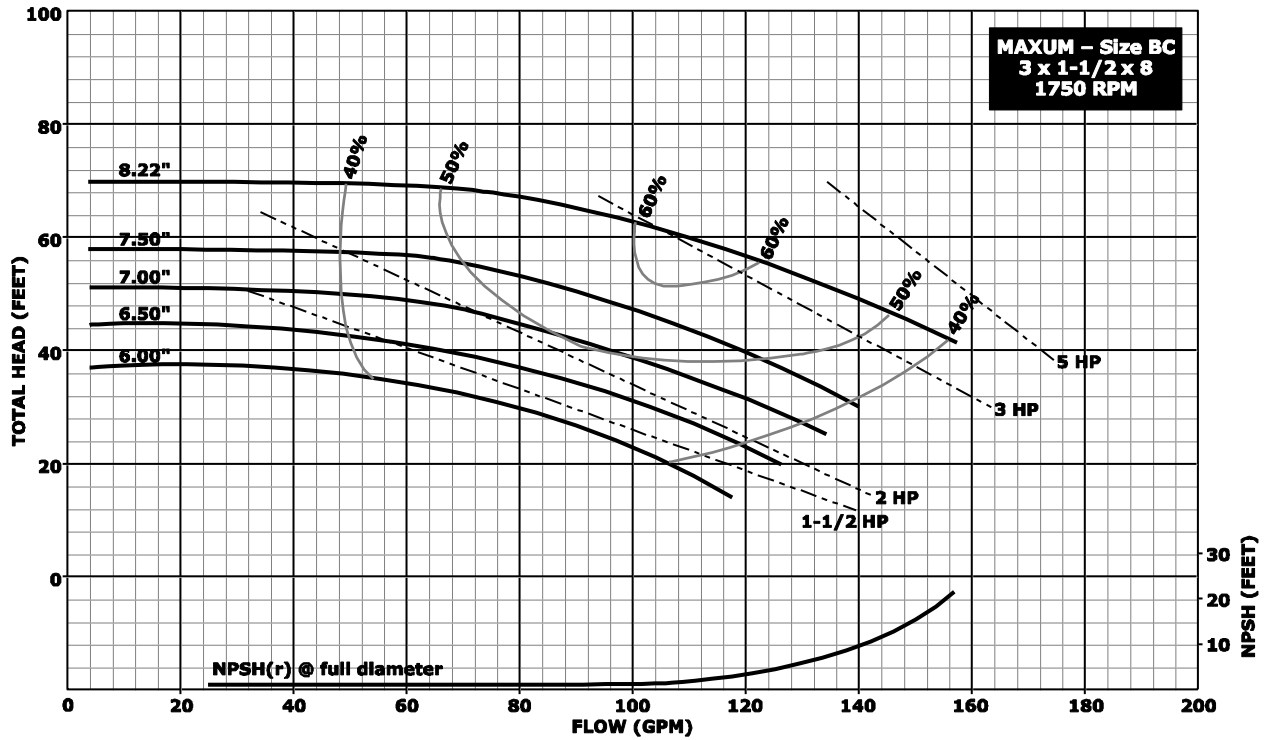
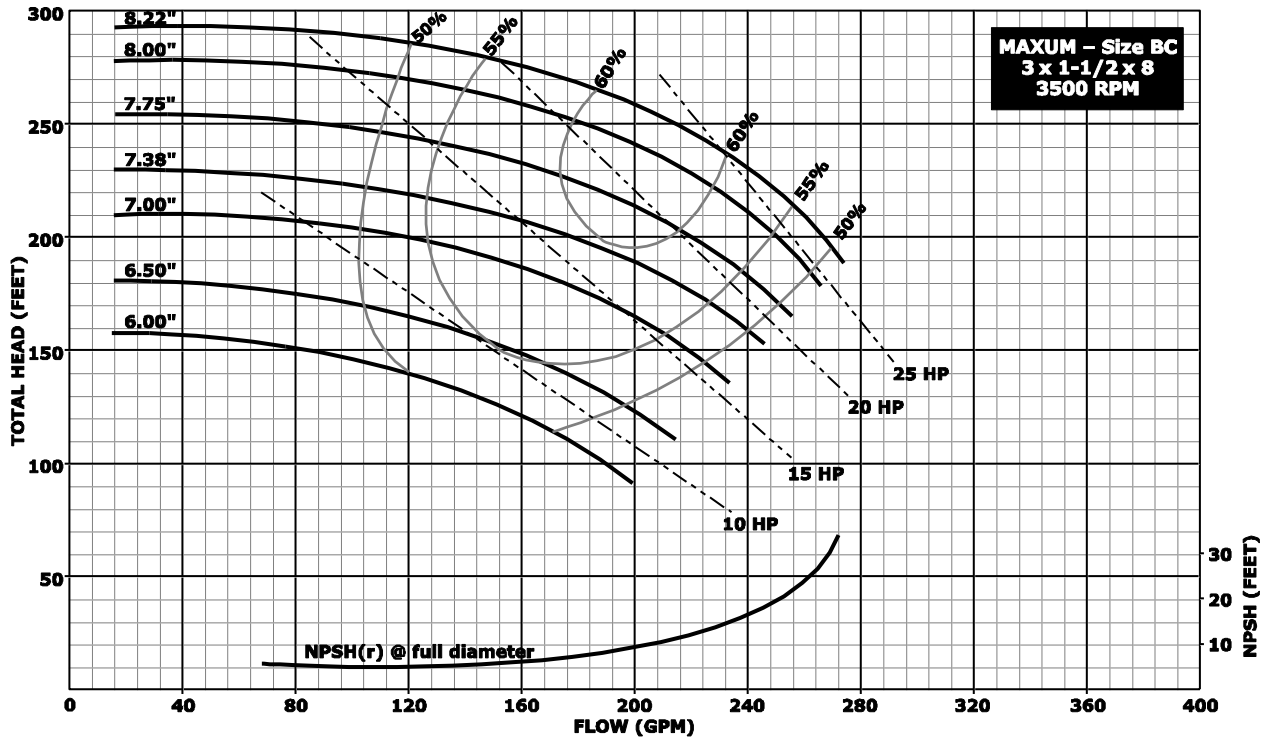

**Notes:**

1. Above data is based on 1.0 sp. gr. water at ambient temperature and pressure in accordance with Hydraulic Institute guidelines.
2. Impeller diameters between minimum and maximum shown are available in 1/8 inch increment trims.

Hydraulic Performance – 8” Impeller Pumps

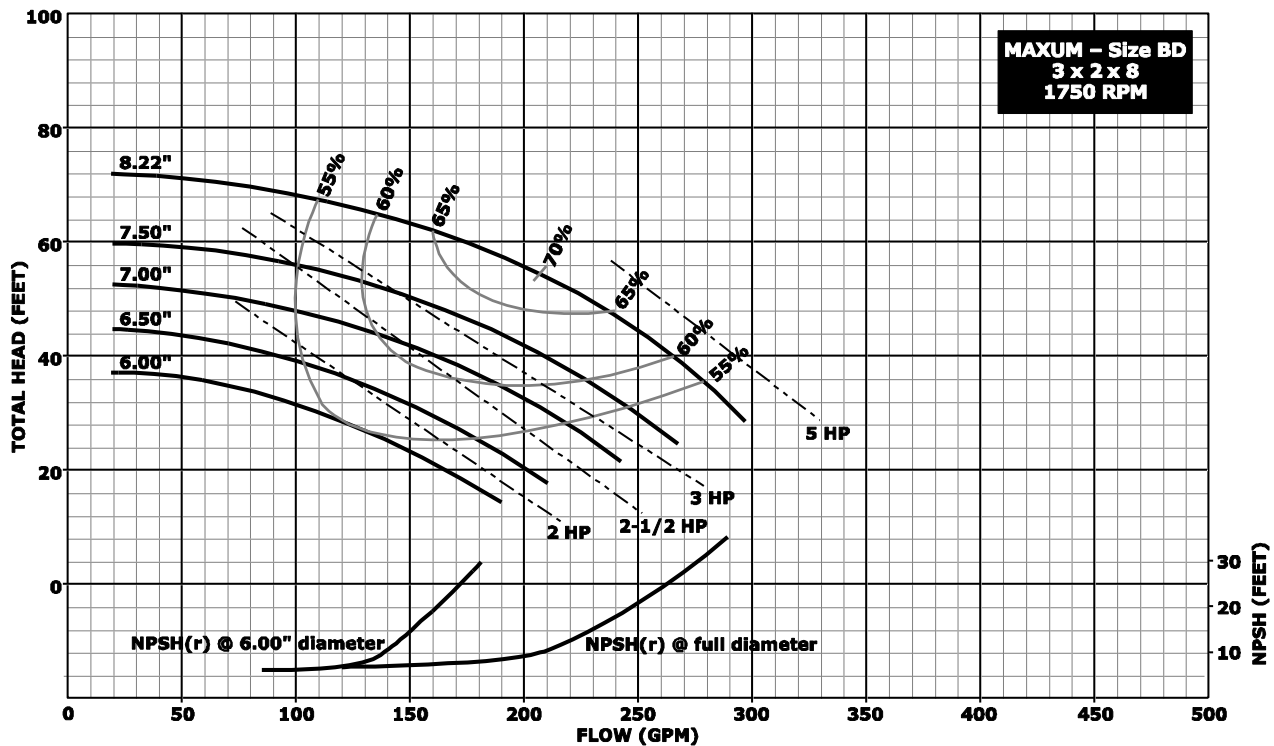
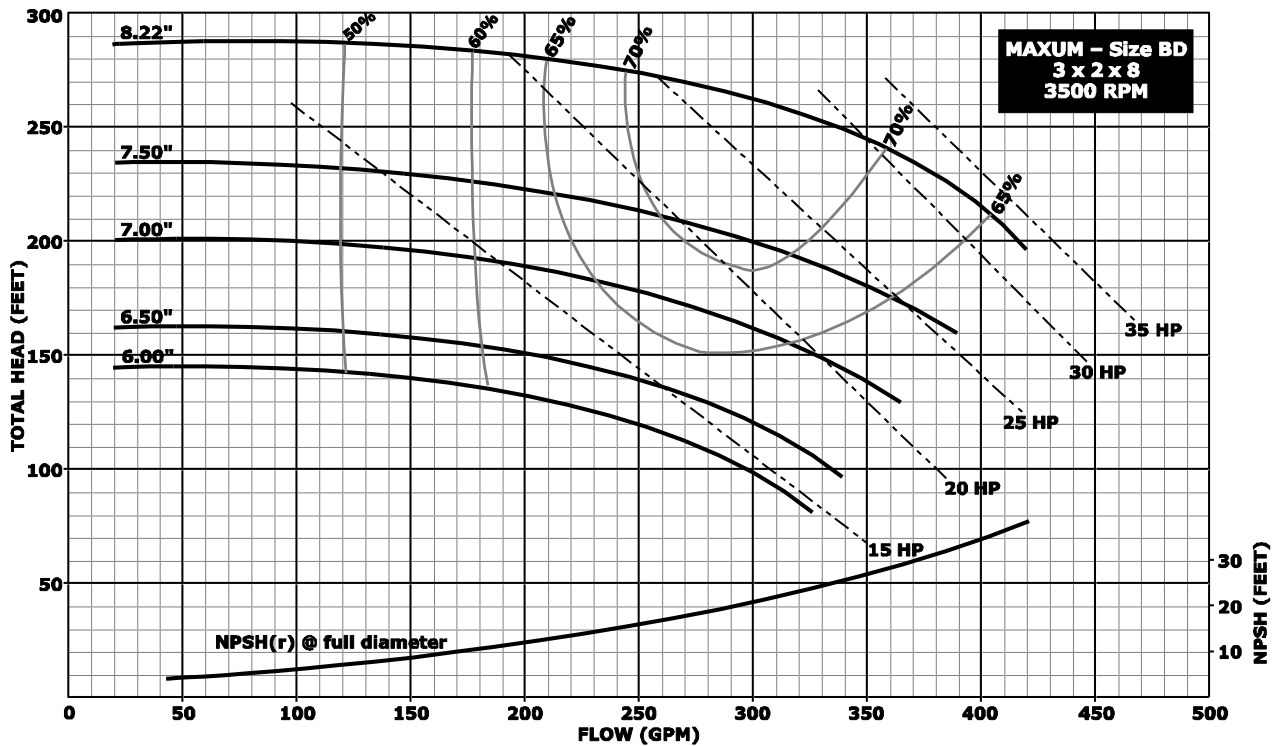

**Notes:**

1. Above data is based on 1.0 sp. gr. water at ambient temperature and pressure in accordance with Hydraulic Institute guidelines.
2. Impeller diameters between minimum and maximum shown are available in 1/8 inch increment trims.

Hydraulic Performance – 8” Impeller Pumps

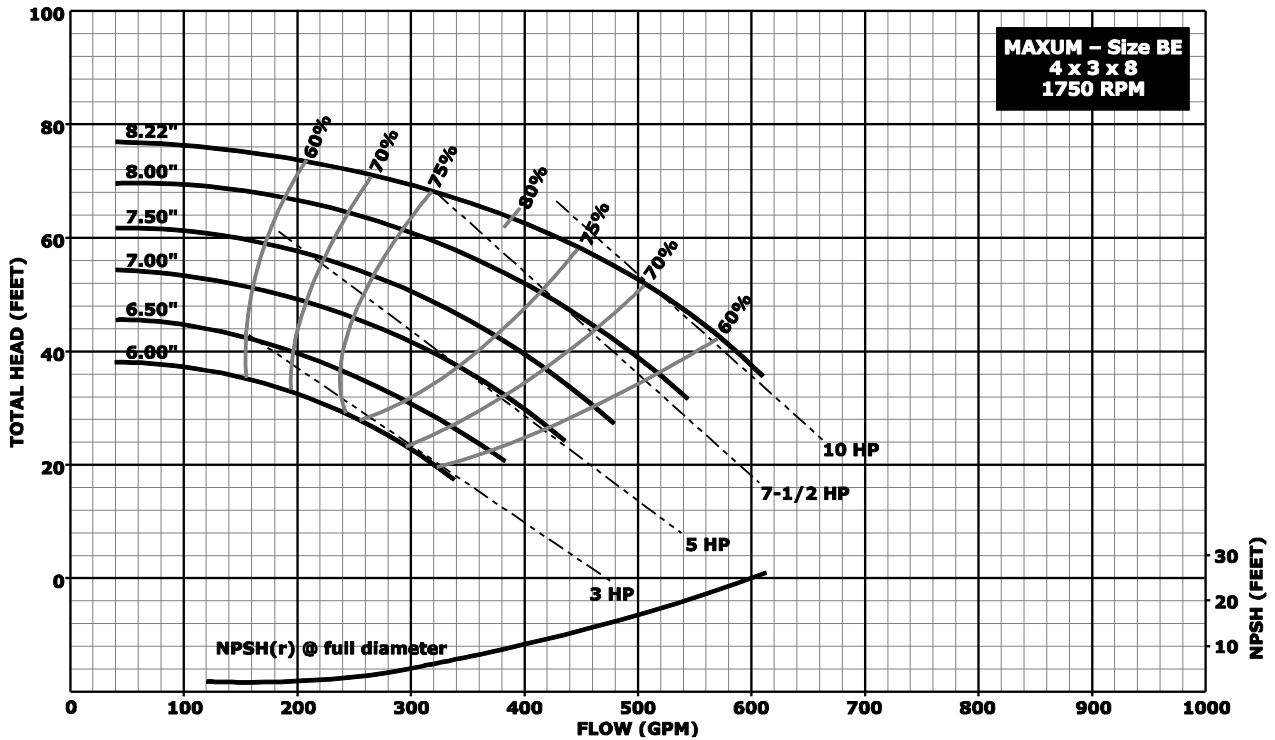
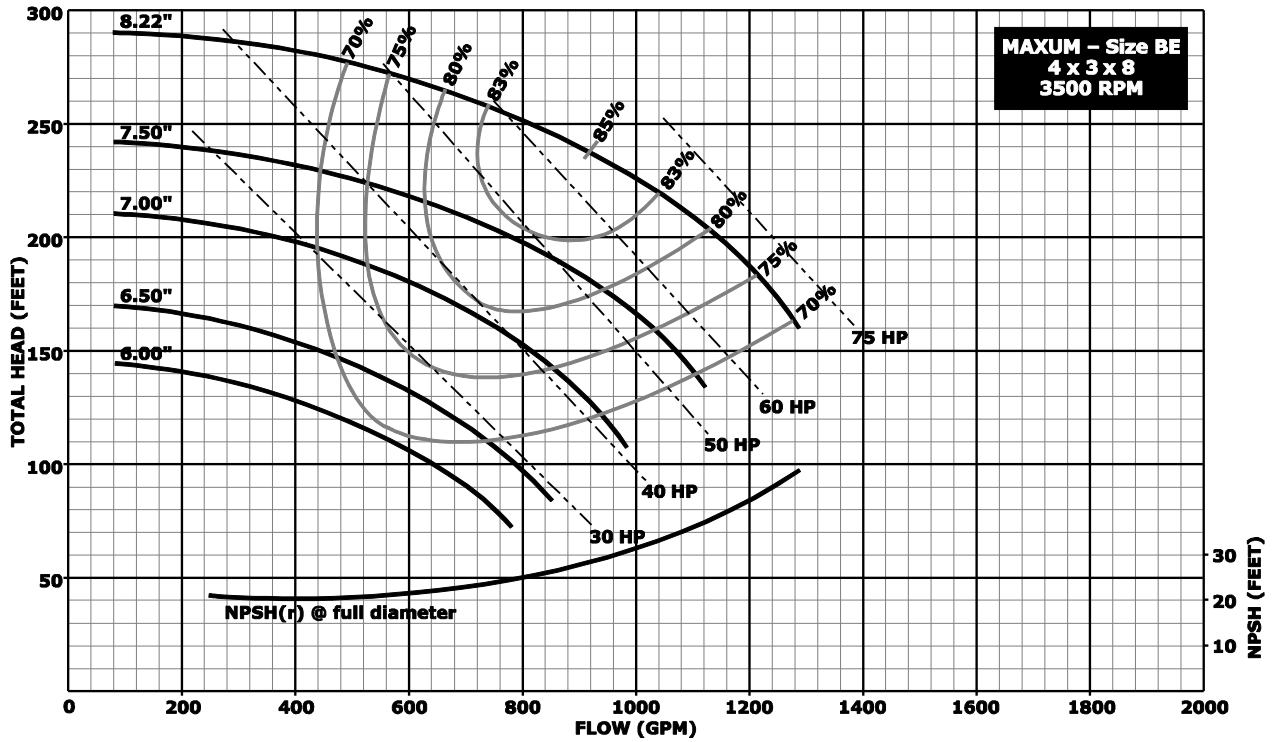

**Notes:**

1. Above data is based on 1.0 sp. gr. water at ambient temperature and pressure in accordance with Hydraulic Institute guidelines.
2. Impeller diameters between minimum and maximum shown are available in 1/8 inch increment trims.

Hydraulic Performance – 8” Impeller Pumps

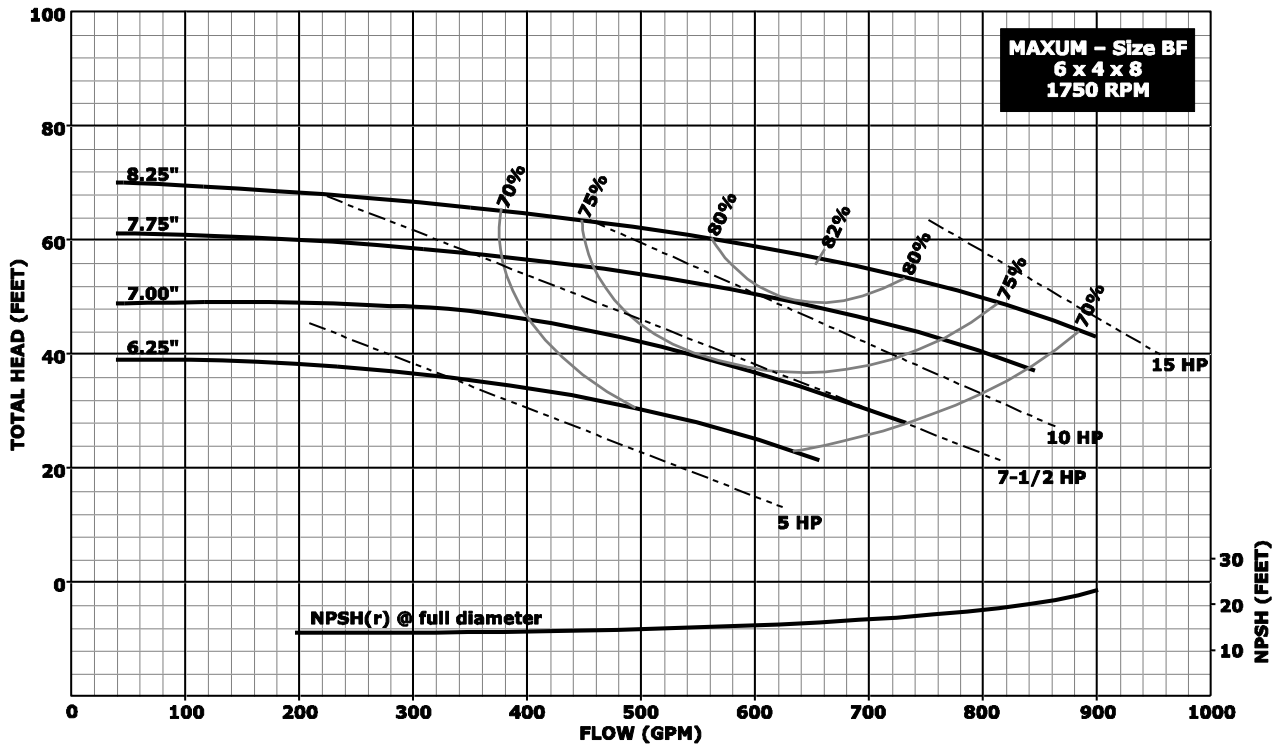
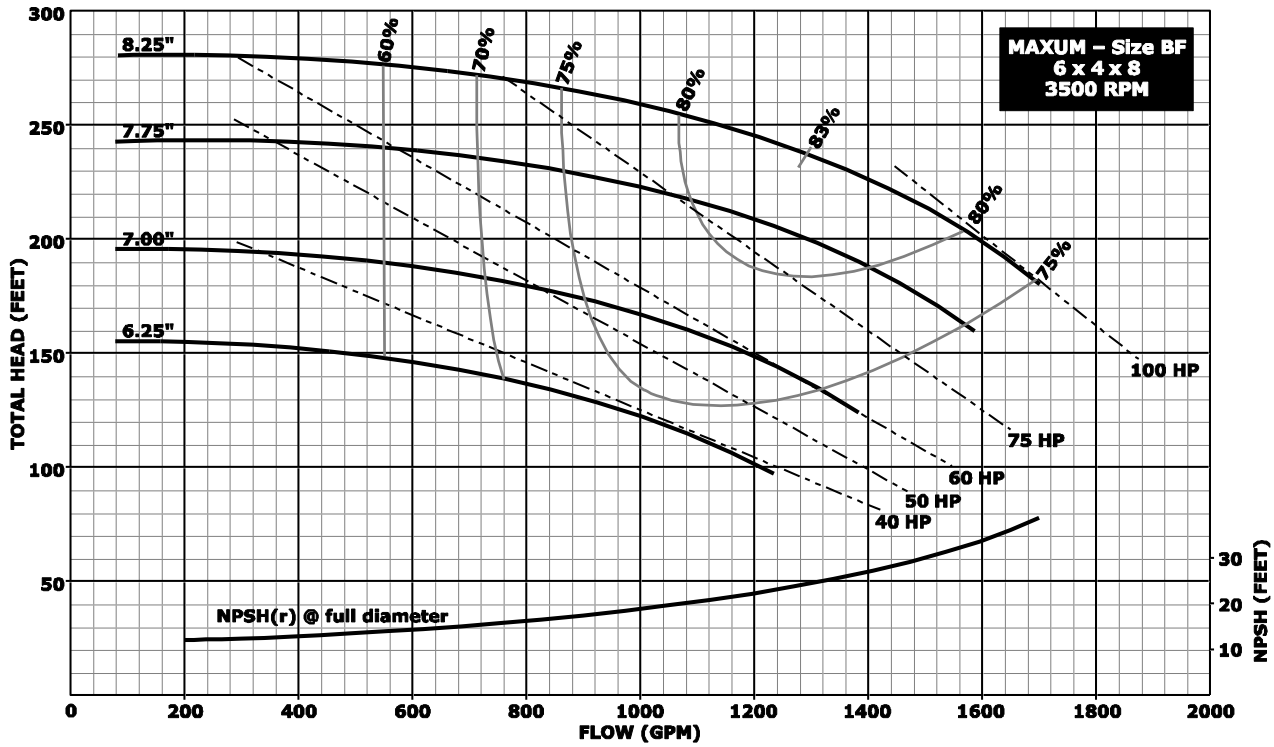

**Notes:**

1. Above data is based on 1.0 sp. gr. water at ambient temperature and pressure in accordance with Hydraulic Institute guidelines.
2. Impeller diameters between minimum and maximum shown are available in 1/8 inch increment trims.

Hydraulic Performance – 10” Impeller Pumps

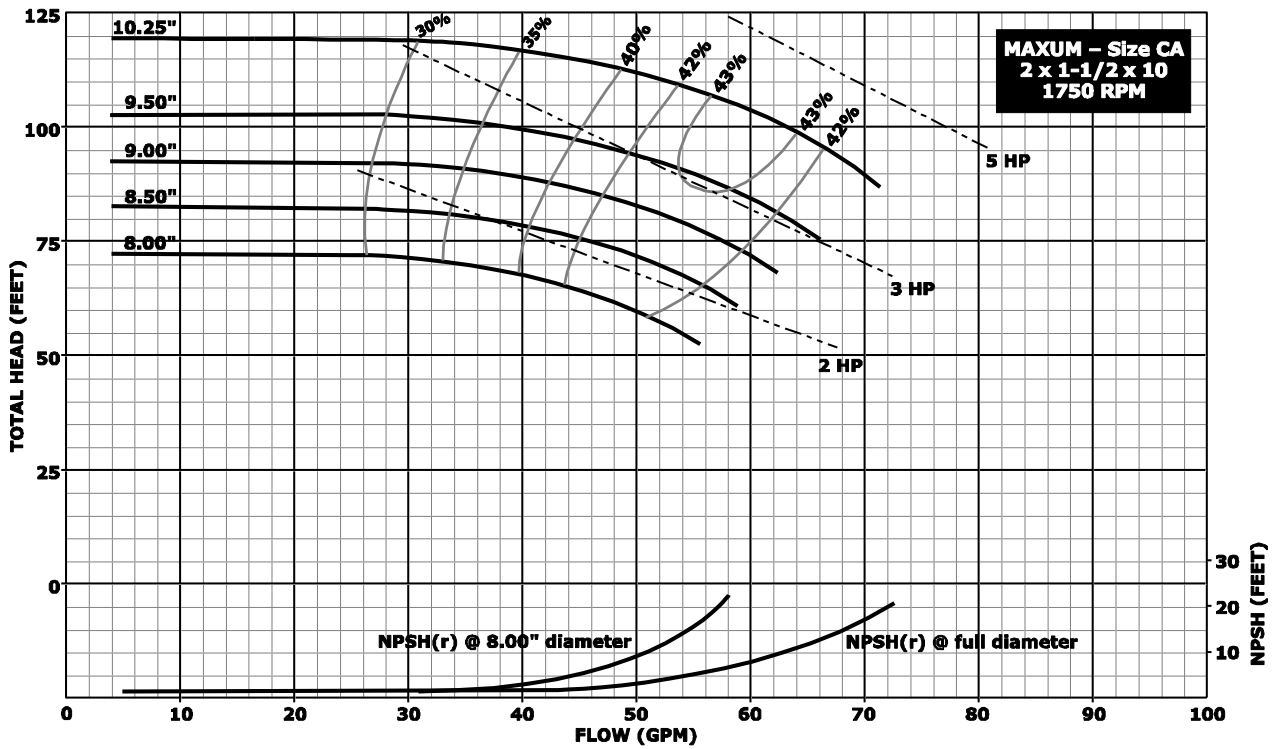
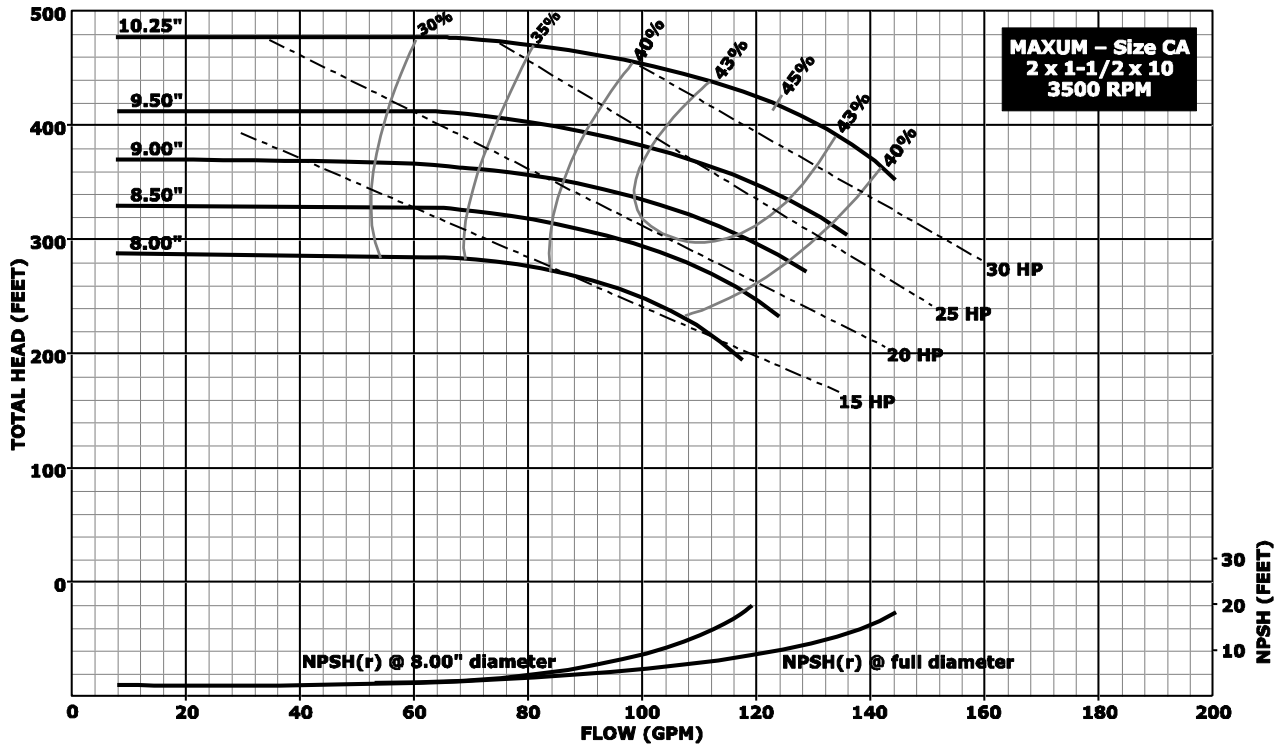

**Notes:**

1. Above data is based on 1.0 sp. gr. water at ambient temperature and pressure in accordance with Hydraulic Institute guidelines.
2. Impeller diameters between minimum and maximum shown are available in 1/8 inch increment trims.

Hydraulic Performance – 10” Impeller Pumps

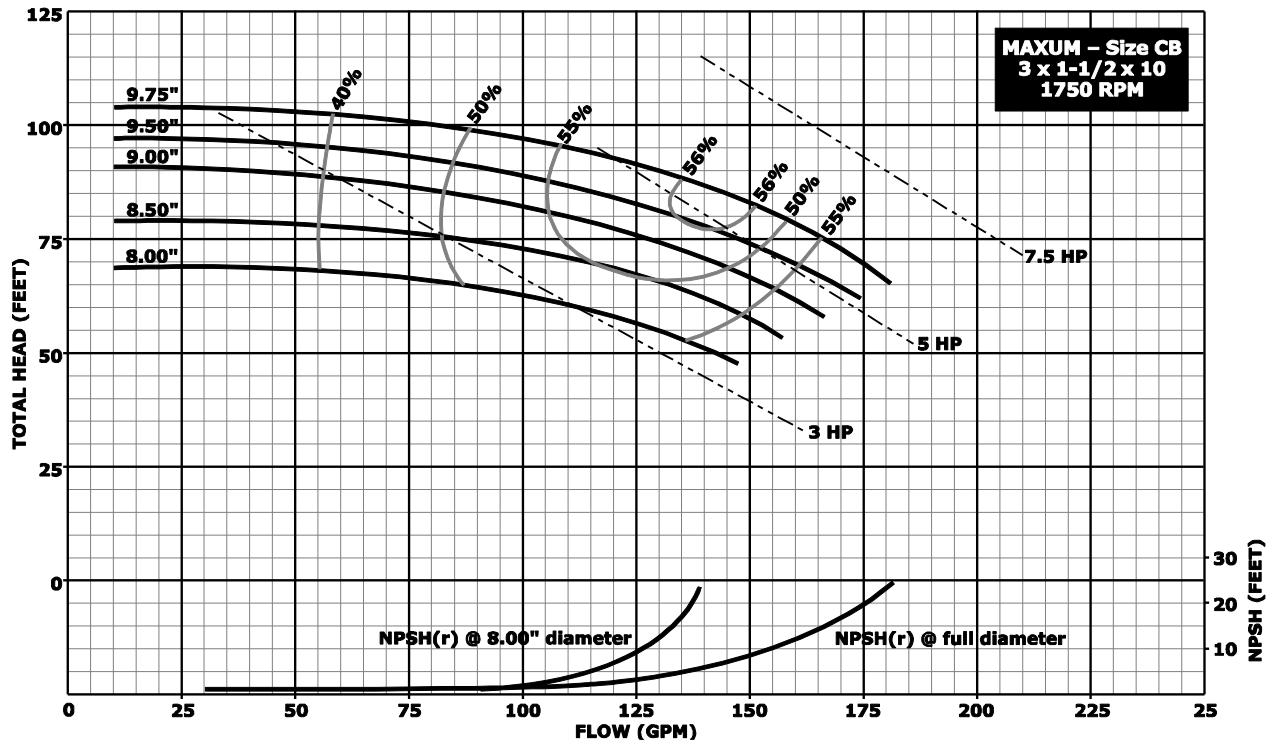
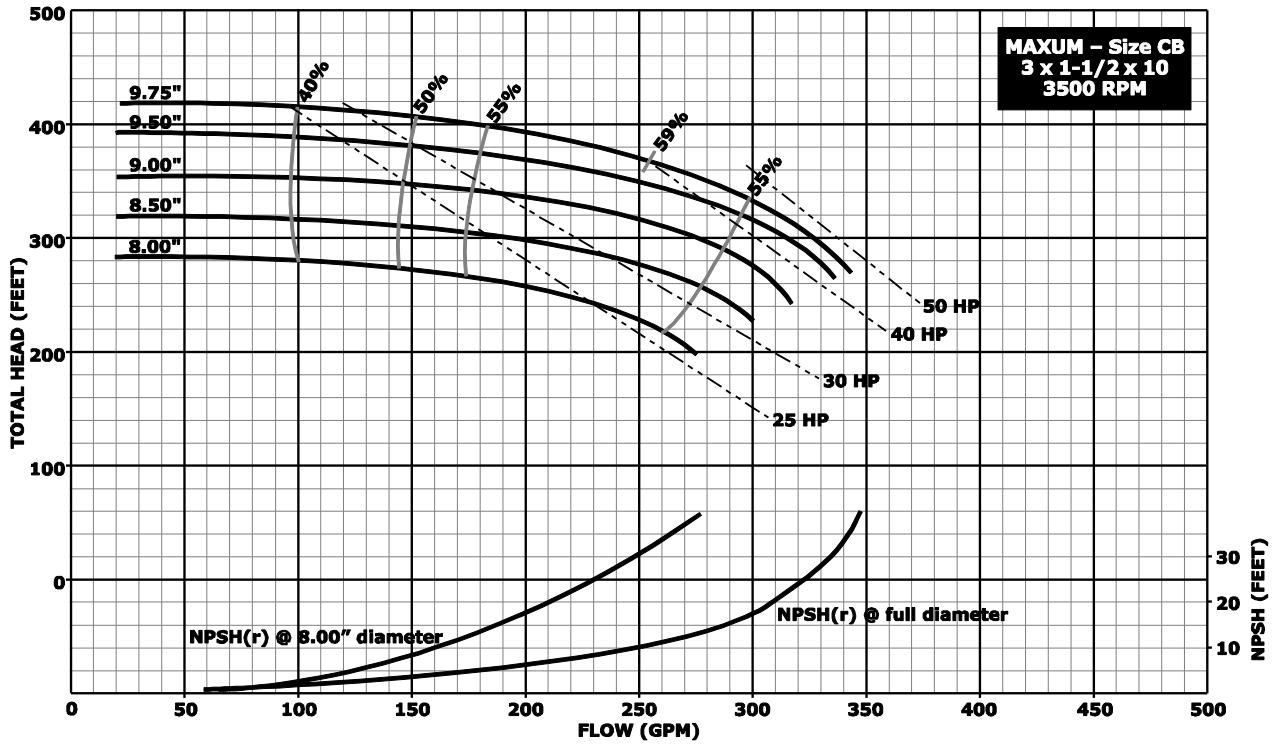

**Notes:**

1. Above data is based on 1.0 sp. gr. water at ambient temperature and pressure in accordance with Hydraulic Institute guidelines.
2. Impeller diameters between minimum and maximum shown are available in 1/8 inch increment trims.

Hydraulic Performance – 10” Impeller Pumps

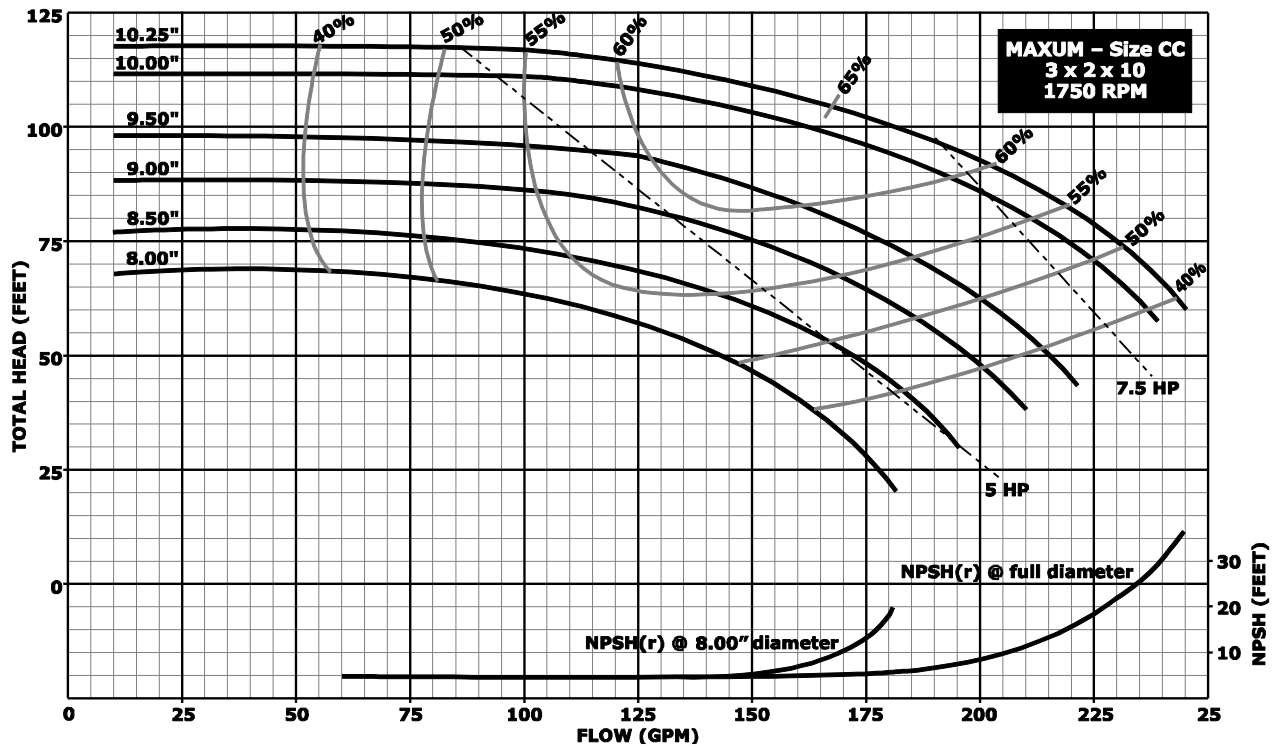
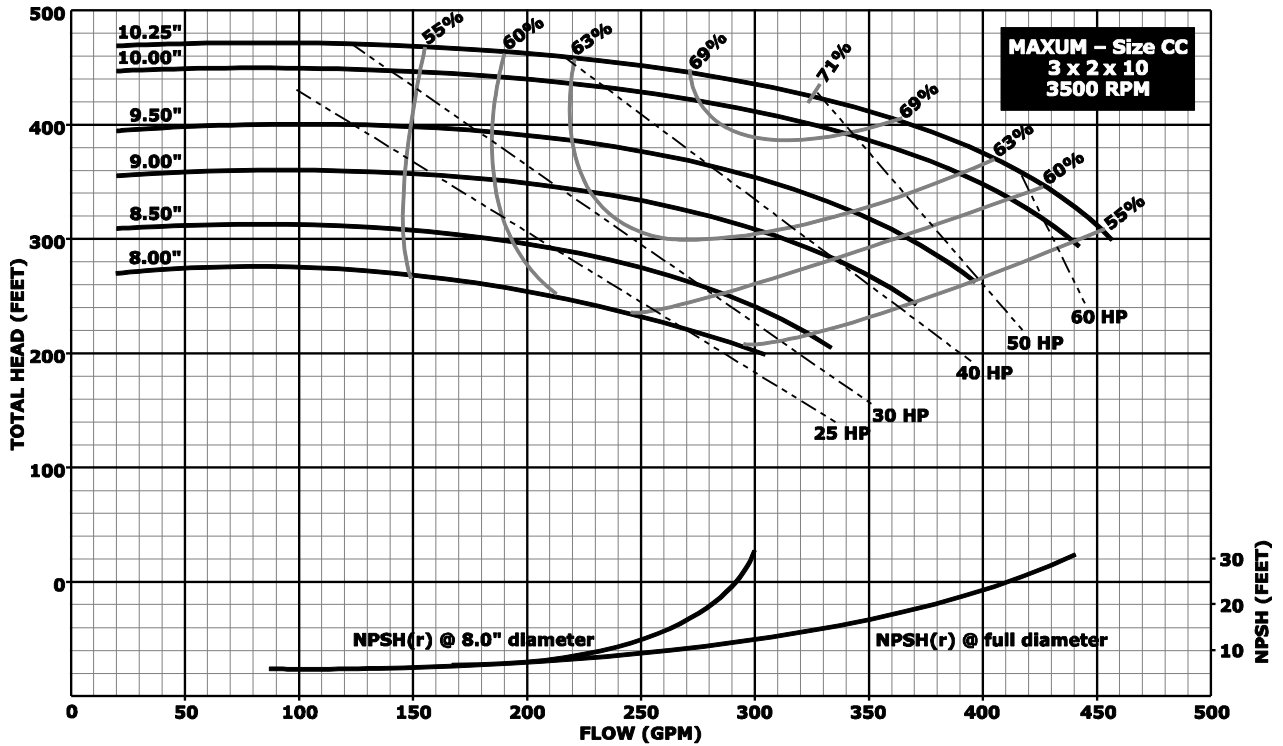

**Notes:**

1. Above data is based on 1.0 sp. gr. water at ambient temperature and pressure in accordance with Hydraulic Institute guidelines.
2. Impeller diameters between minimum and maximum shown are available in 1/8 inch increment trims.

Hydraulic Performance – 10” Impeller Pumps

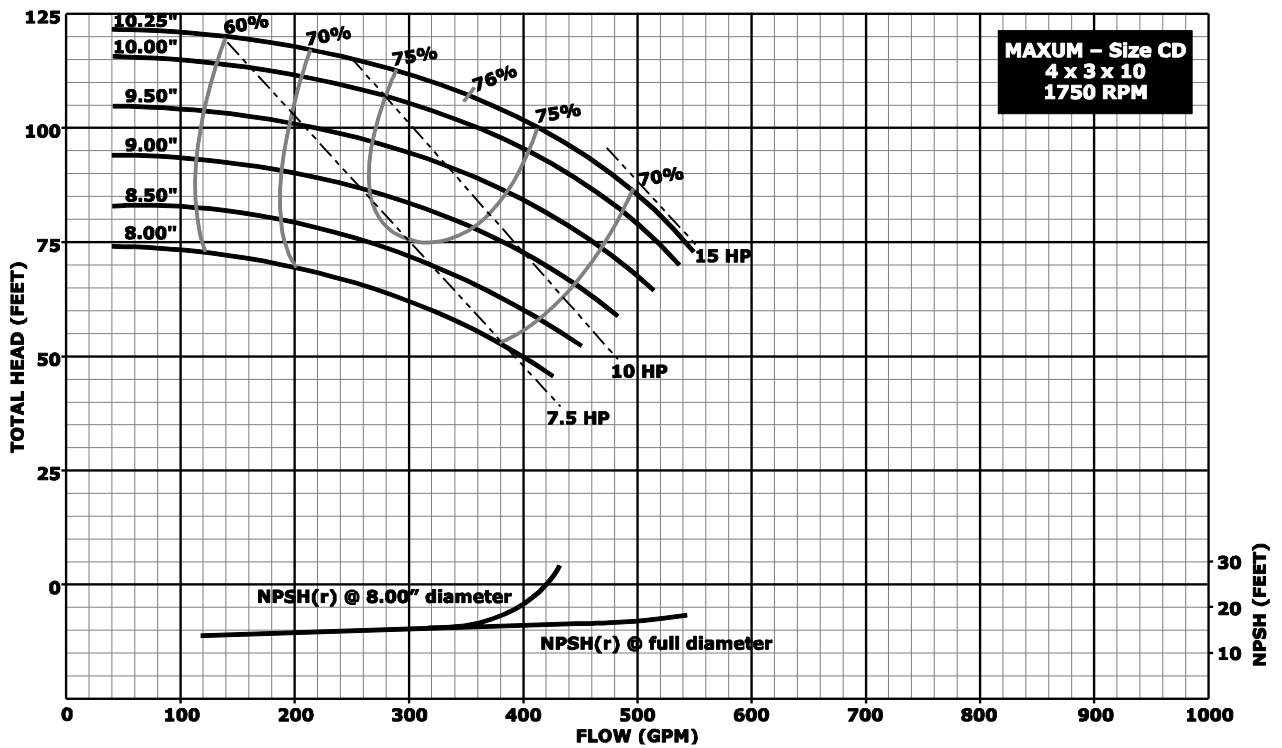
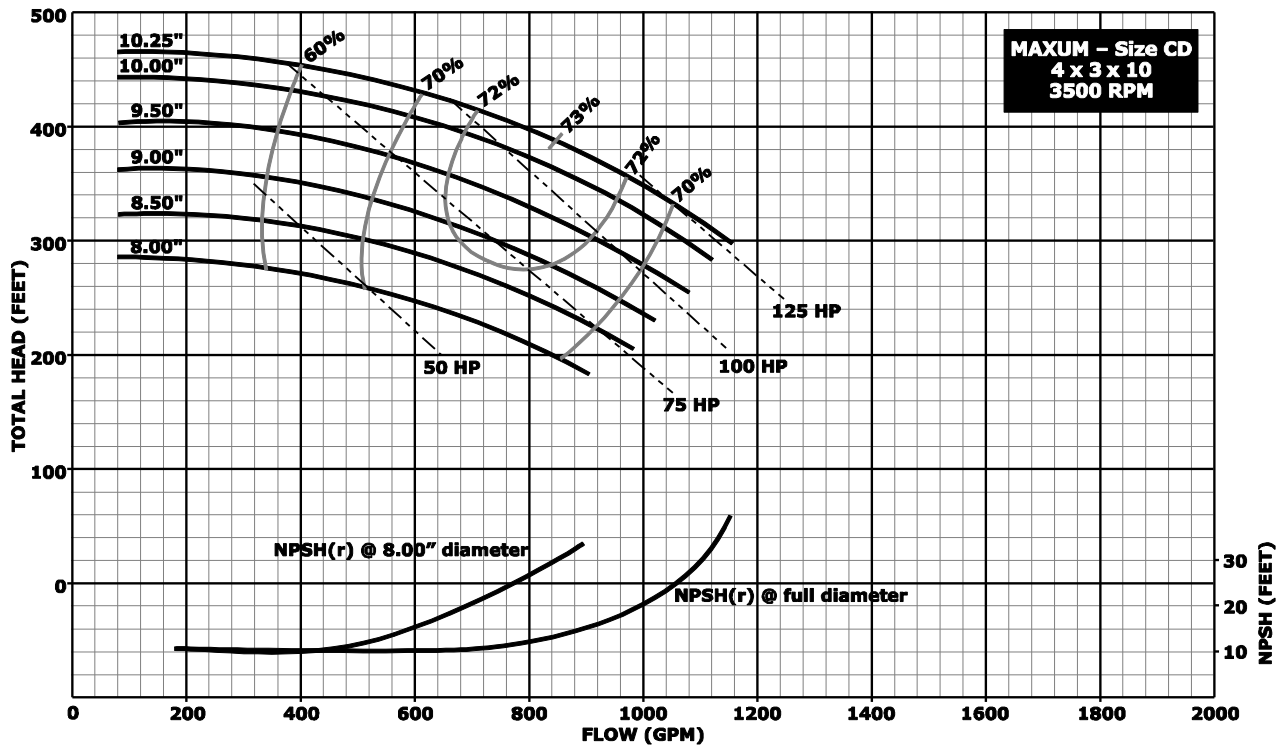

**Notes:**

1. Above data is based on 1.0 sp. gr. water at ambient temperature and pressure in accordance with Hydraulic Institute guidelines.
2. Impeller diameters between minimum and maximum shown are available in 1/8 inch increment trims.

Hydraulic Performance – 10” Impeller Pumps

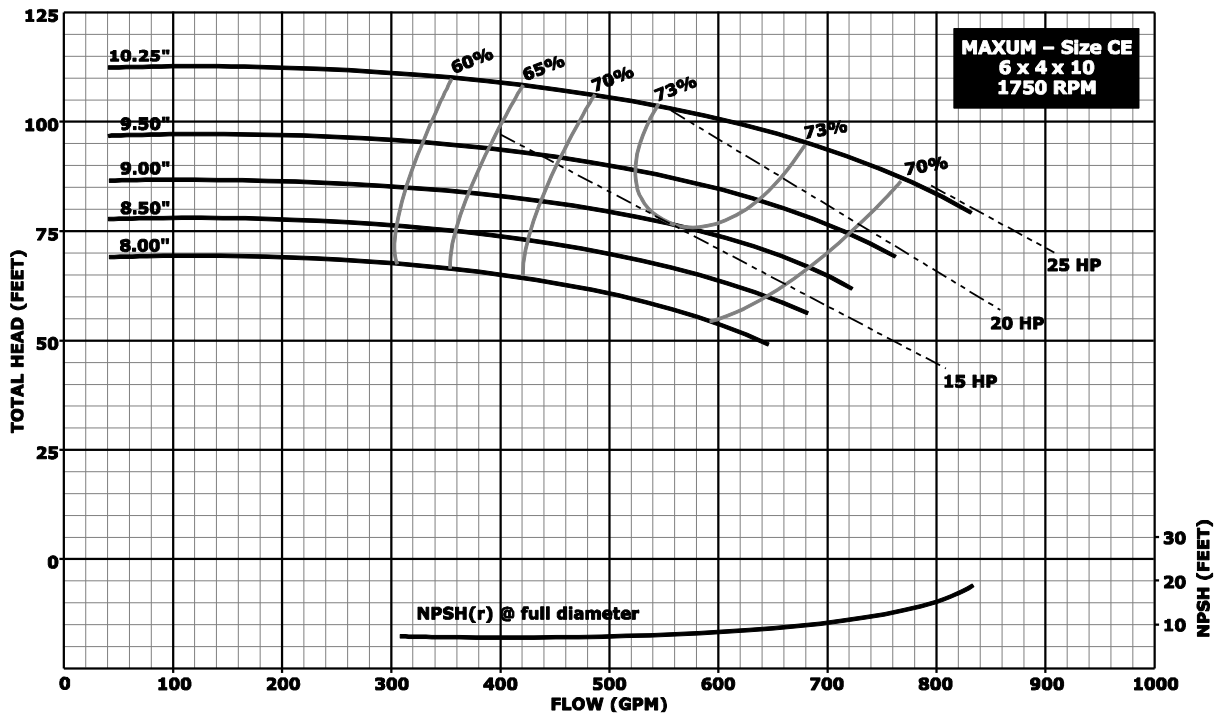
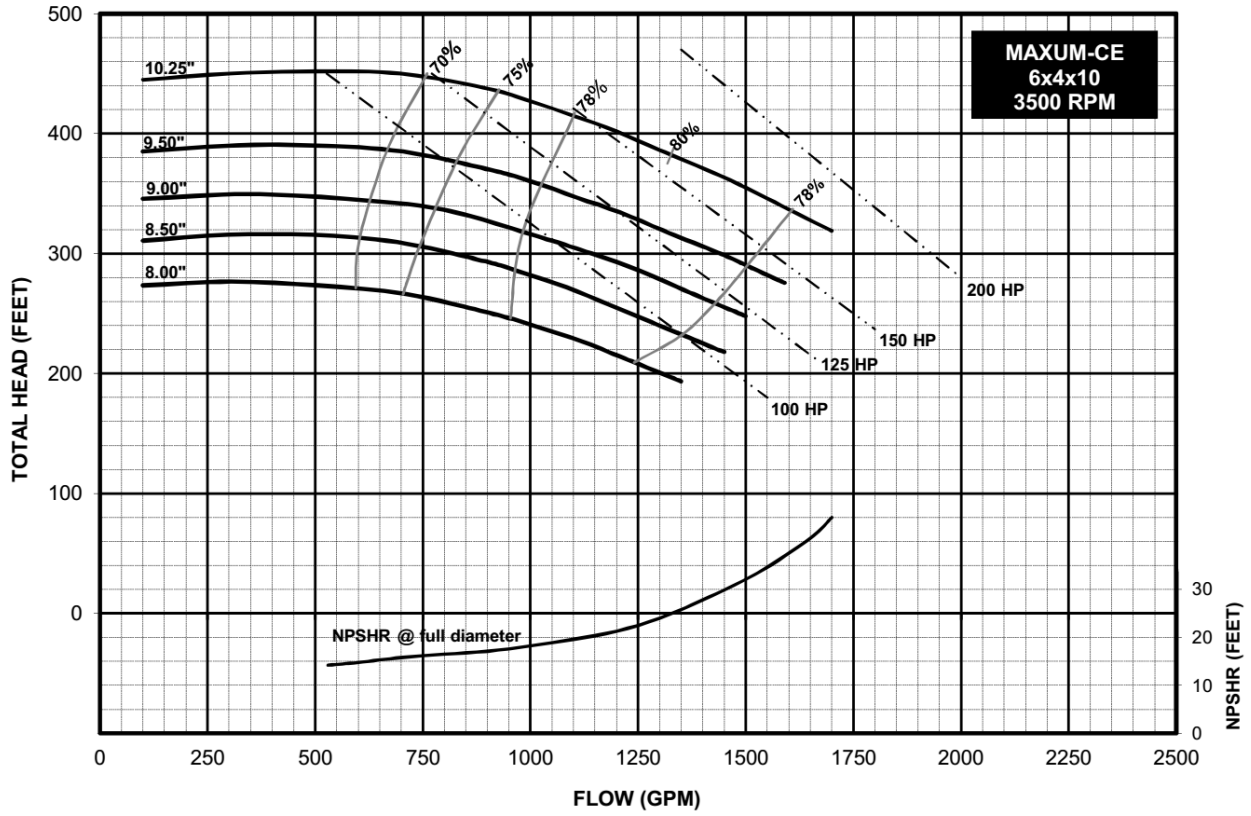

**Notes:**

1. Above data is based on 1.0 sp. gr. water at ambient temperature and pressure in accordance with Hydraulic Institute guidelines.
2. Impeller diameters between minimum and maximum shown are available in 1/8 inch increment trims.

Hydraulic Performance – 10” Impeller Pumps

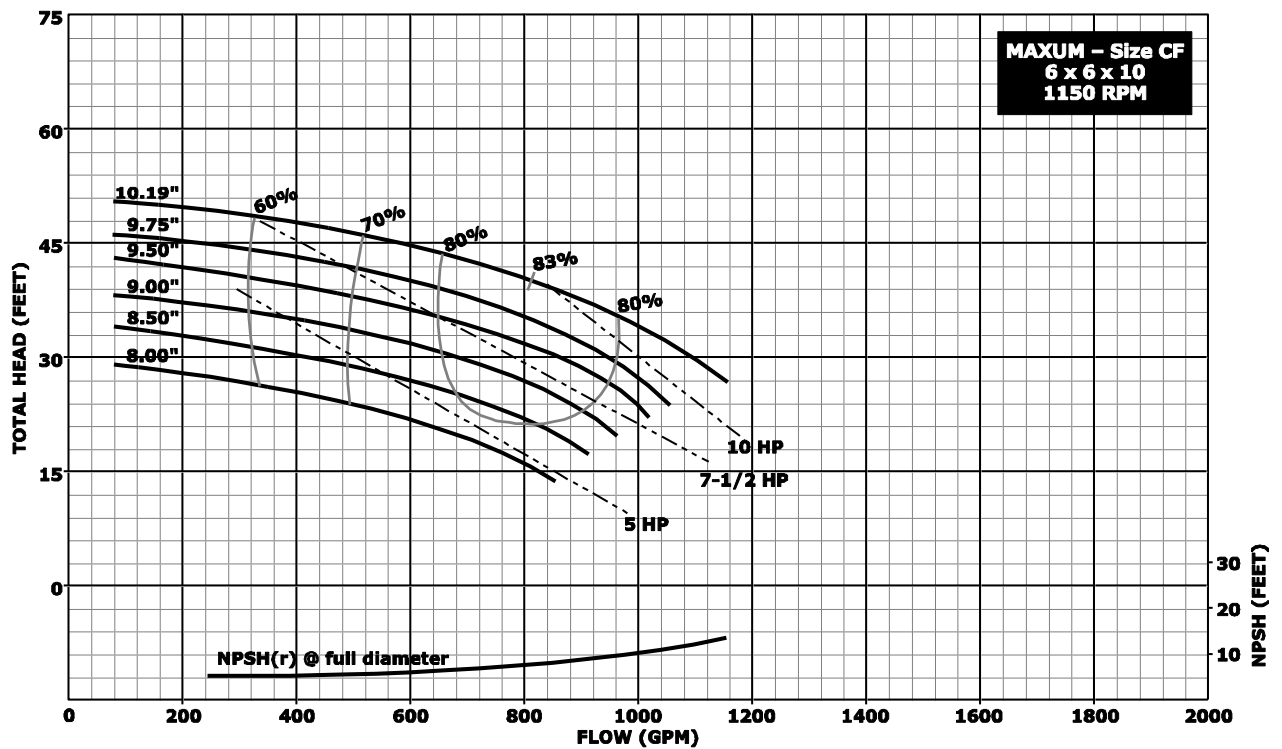
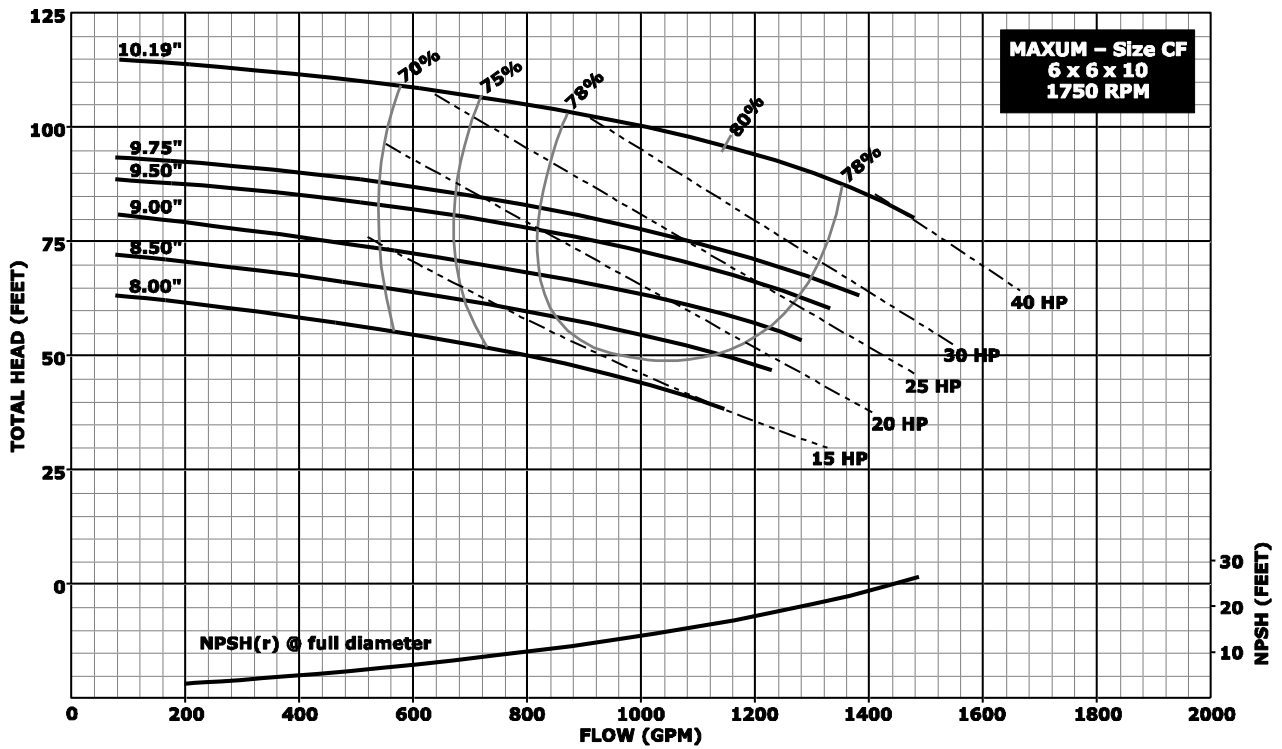

Notes:

1. Above data is based on 1.0 sp. gr. water at ambient temperature and pressure in accordance with Hydraulic Institute guidelines.
2. Impeller diameters between minimum and maximum shown are available in 1/8 inch increment trims.

Hydraulic Performance – 10” Impeller Pumps

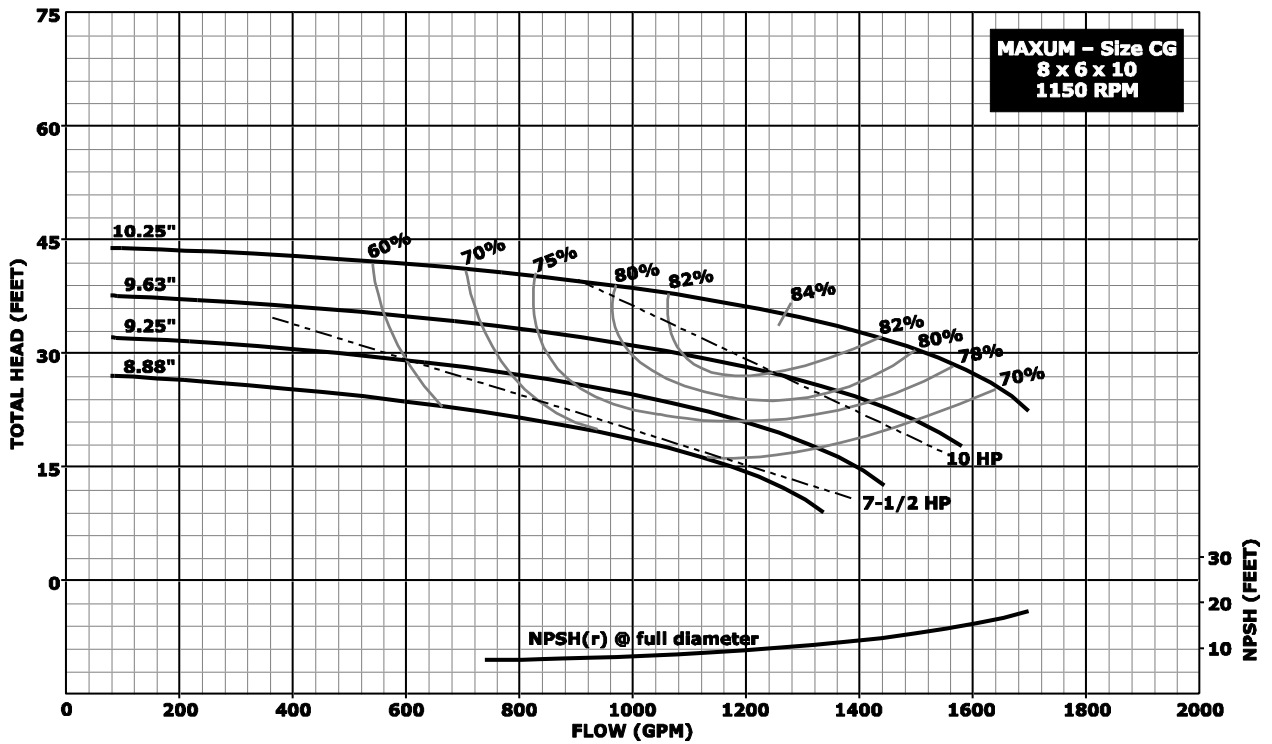
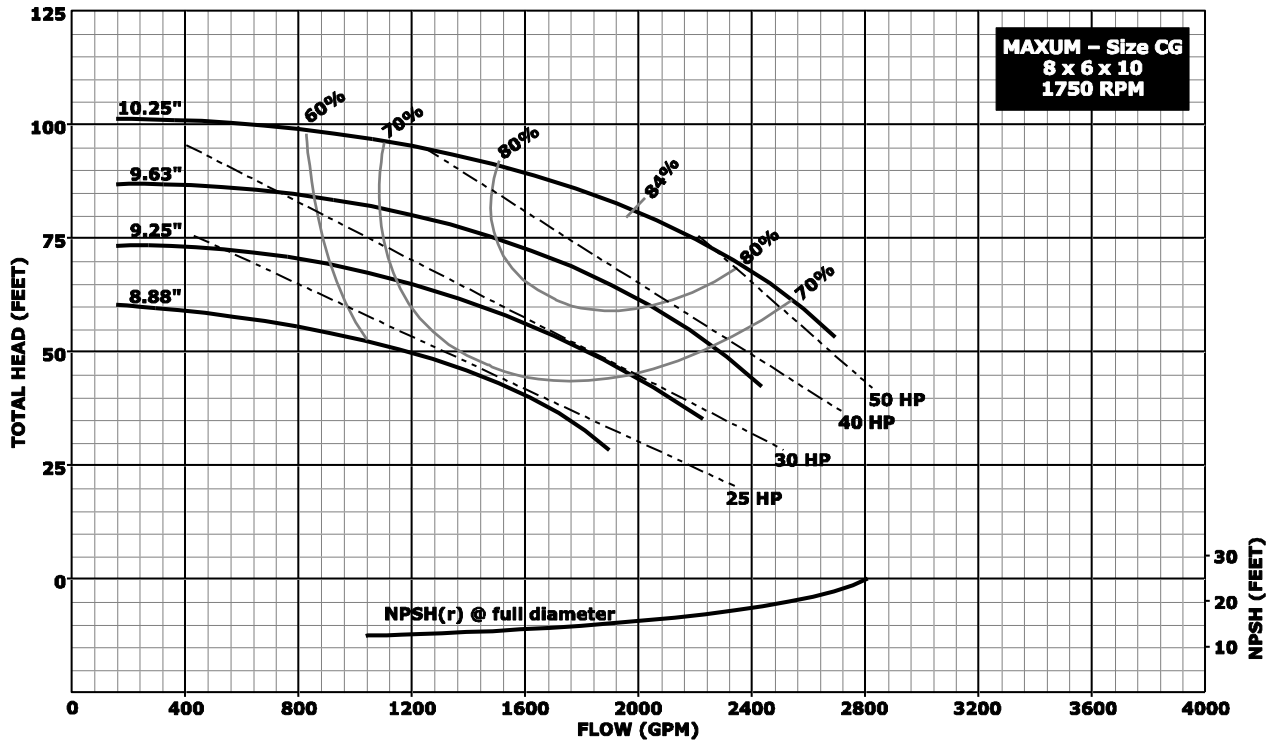

**Notes:**

1. Above data is based on 1.0 sp. gr. water at ambient temperature and pressure in accordance with Hydraulic Institute guidelines.
2. Impeller diameters between minimum and maximum shown are available in 1/8 inch increment trims.

Hydraulic Performance – 13” Impeller Pumps

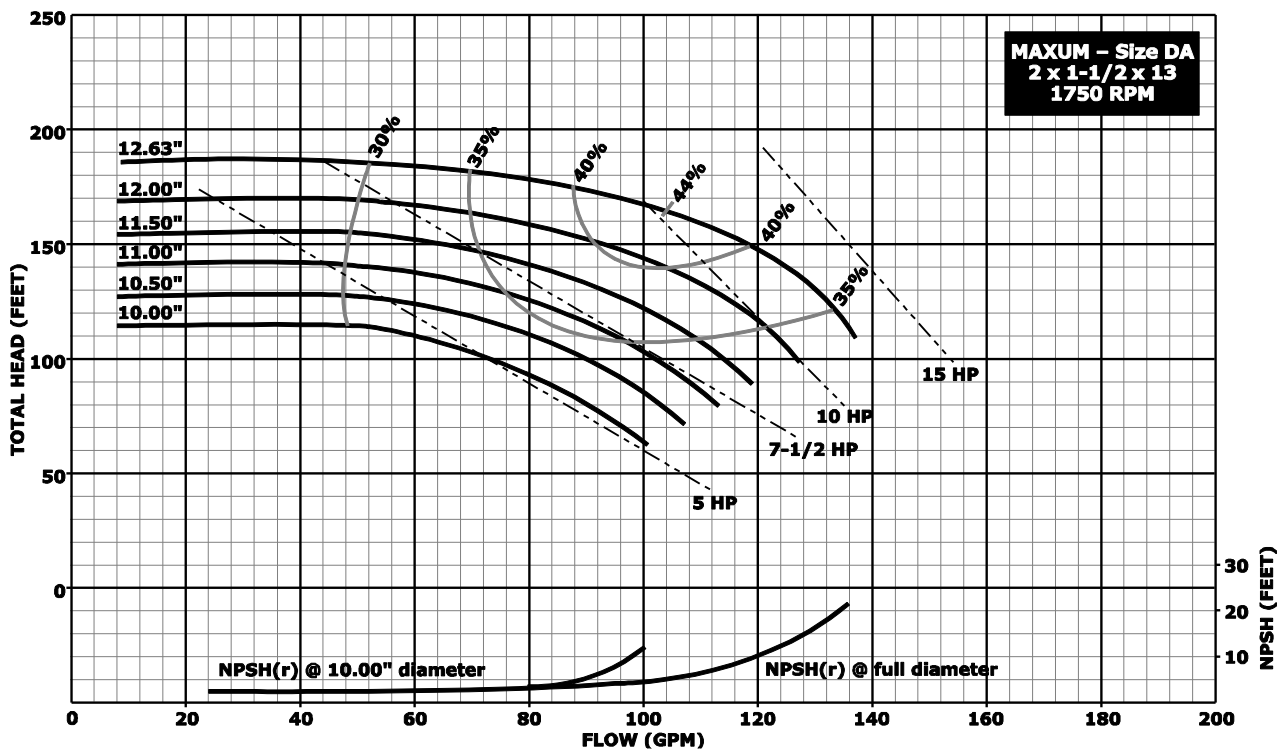
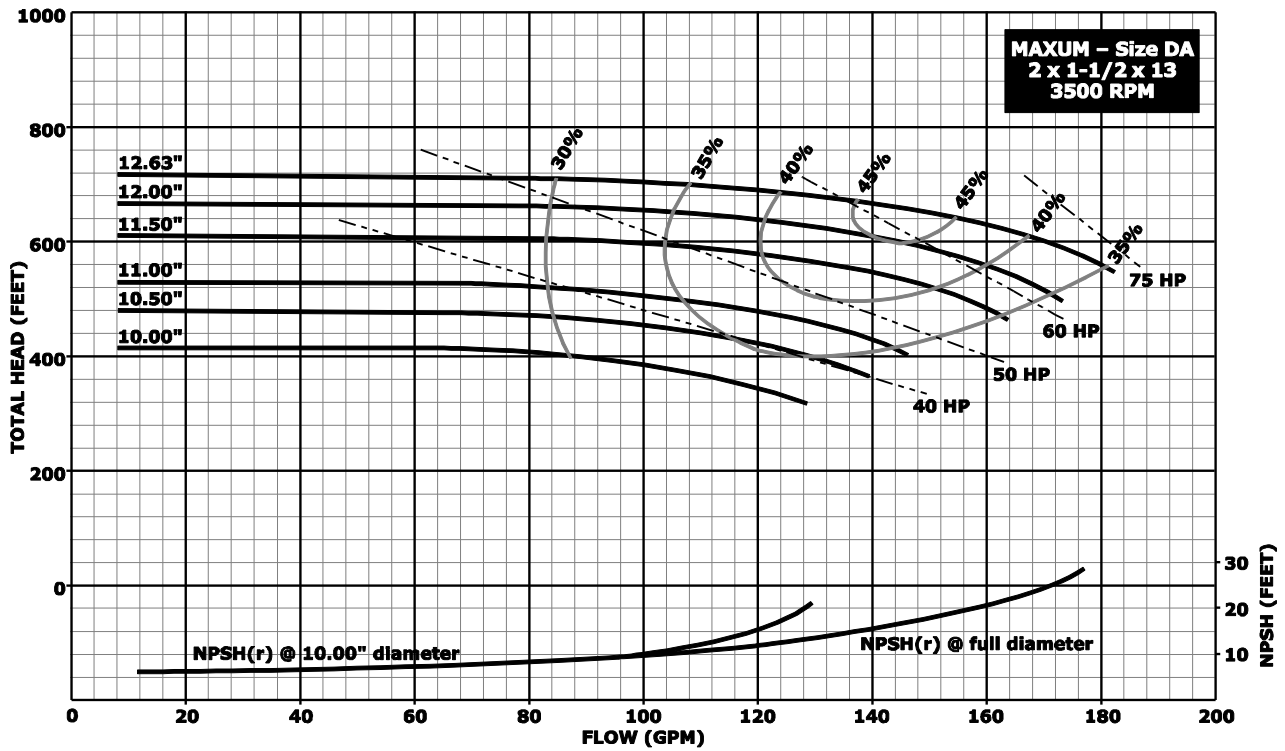

Notes:

1. Above data is based on 1.0 sp. gr. water at ambient temperature and pressure in accordance with Hydraulic Institute guidelines.
2. Impeller diameters between minimum and maximum shown are available in 1/8 inch increment trims.

Hydraulic Performance – 13” Impeller Pumps

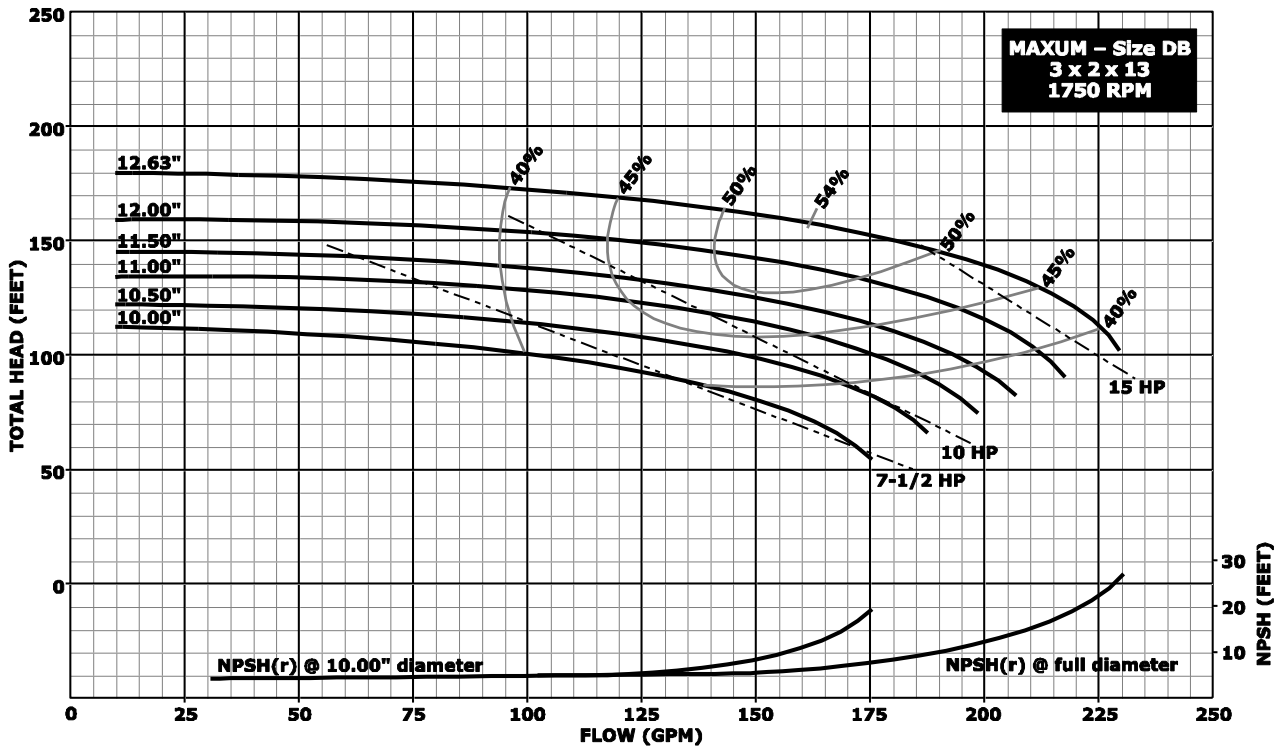
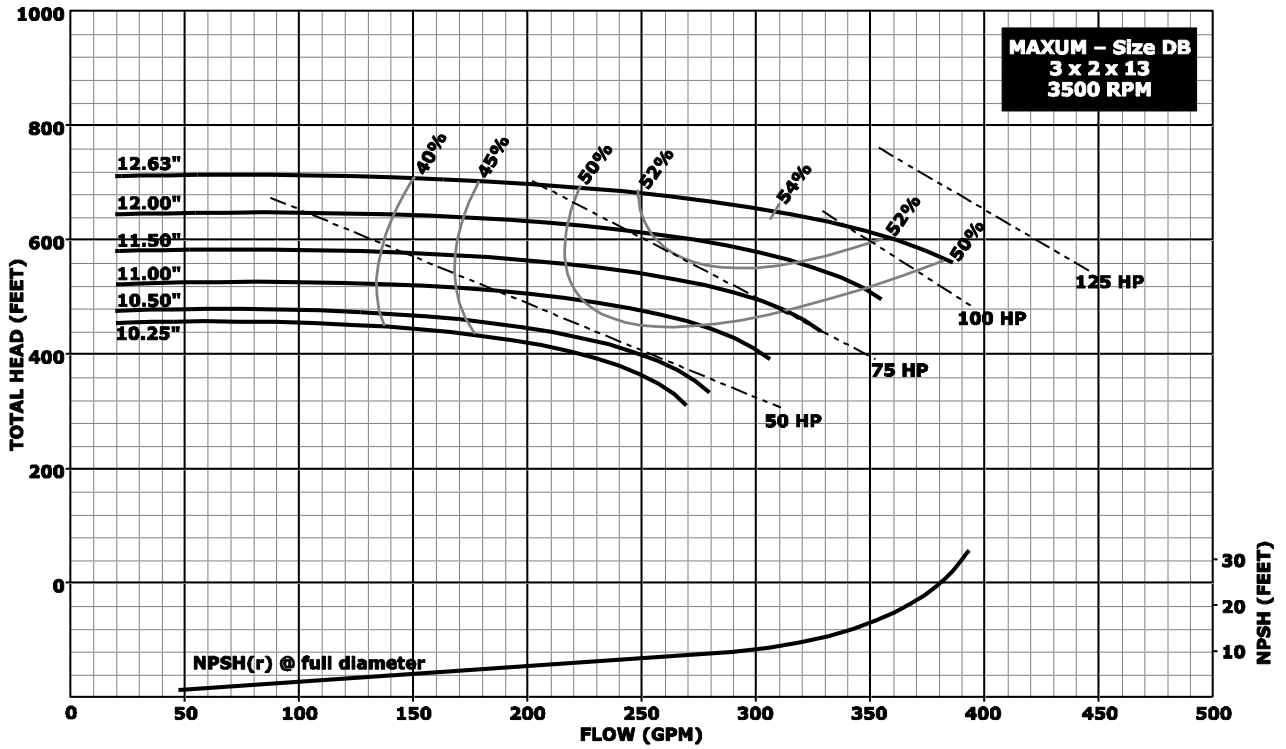

**Notes:**

1. Above data is based on 1.0 sp. gr. water at ambient temperature and pressure in accordance with Hydraulic Institute guidelines.
2. Impeller diameters between minimum and maximum shown are available in 1/8 inch increment trims.

### Hydraulic Performance – 13” Impeller Pumps

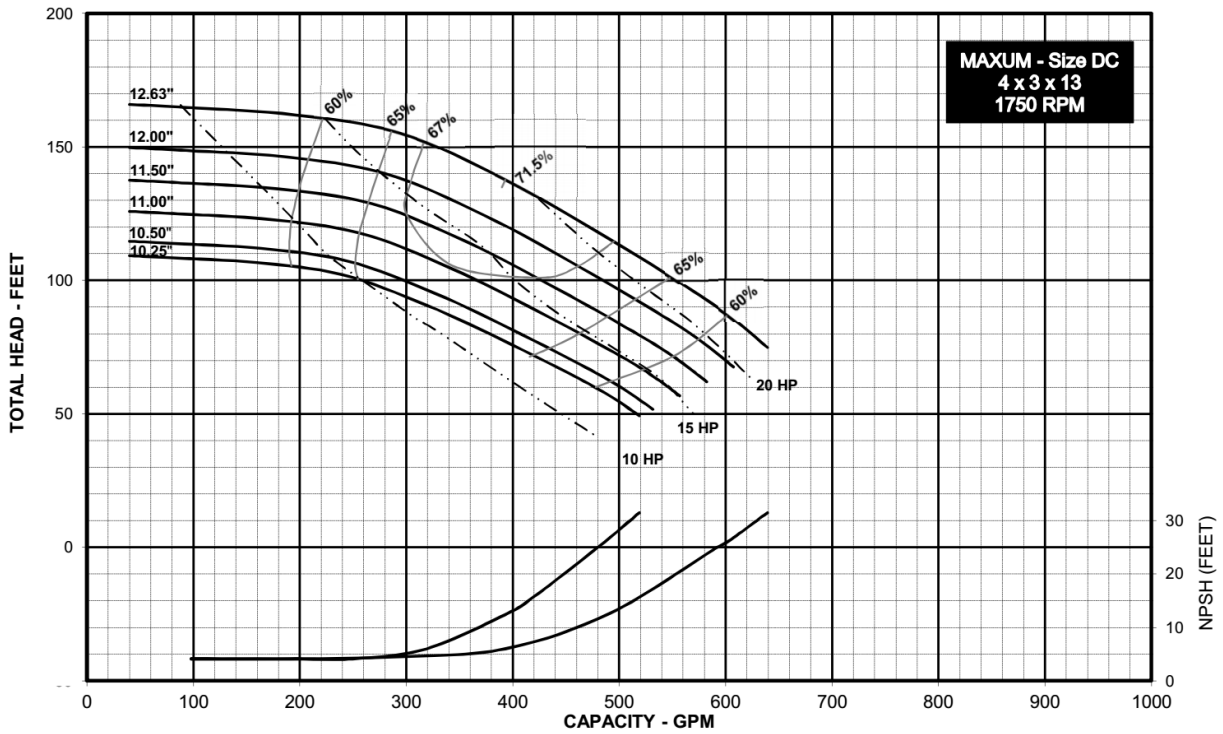
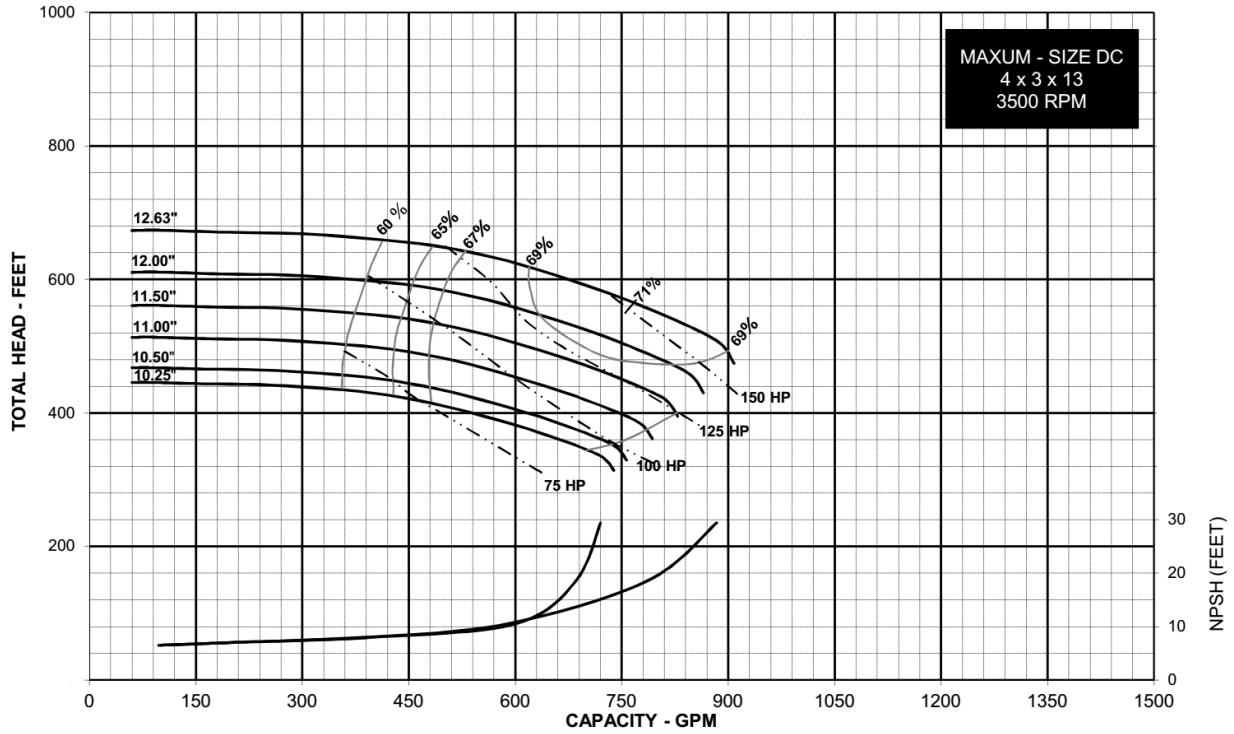

**Notes:**

1. Above data is based on 1.0 sp. gr. water at ambient temperature and pressure in accordance with Hydraulic Institute guidelines.
2. Impeller diameters between minimum and maximum shown are available in 1/8 inch increment trims.

Hydraulic Performance – 13” Impeller Pumps

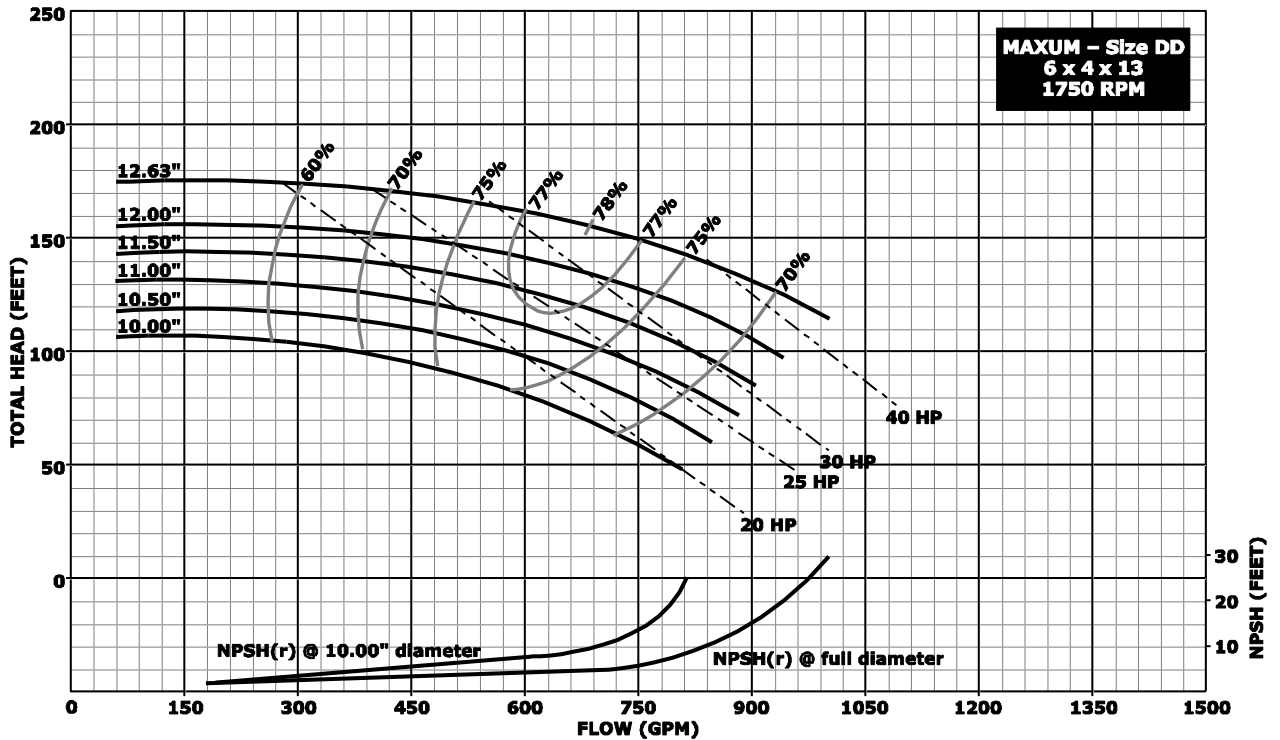
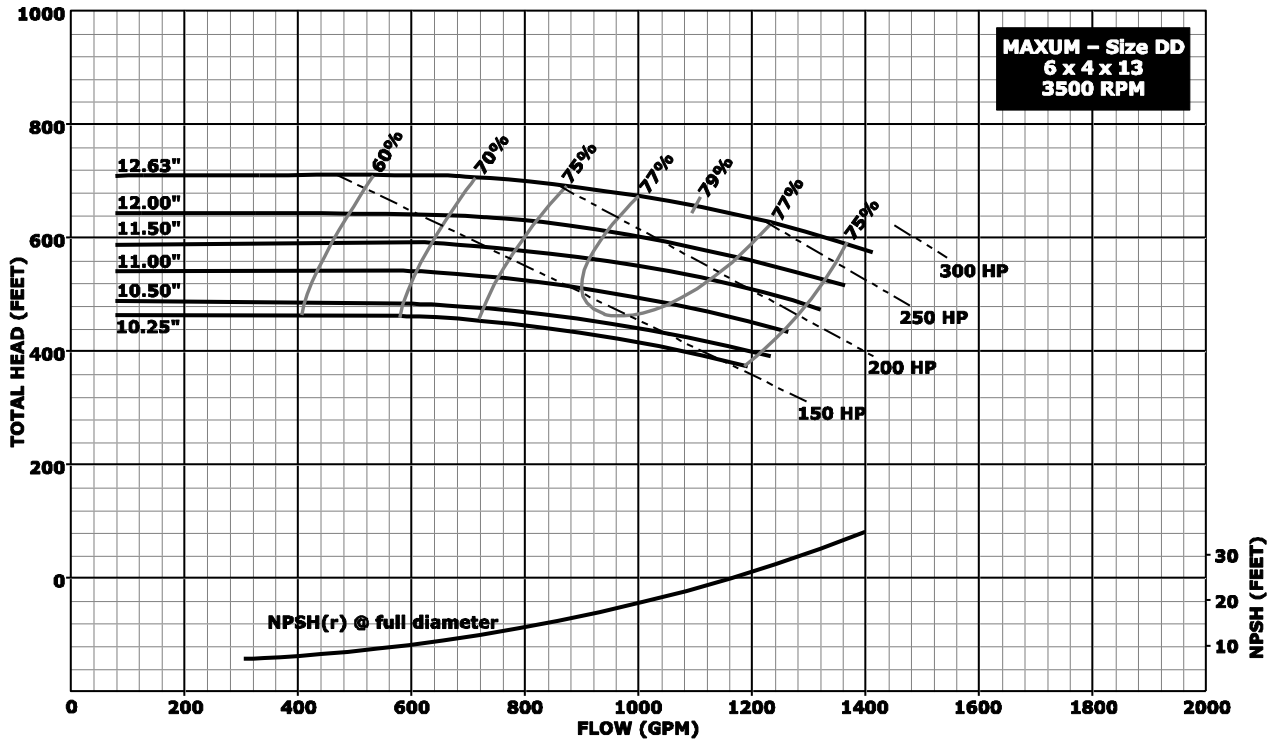

Notes:

1. Above data is based on 1.0 sp. gr. water at ambient temperature and pressure in accordance with Hydraulic Institute guidelines.
2. Impeller diameters between minimum and maximum shown are available in 1/8 inch increment trims.

Hydraulic Performance – 13” Impeller Pumps

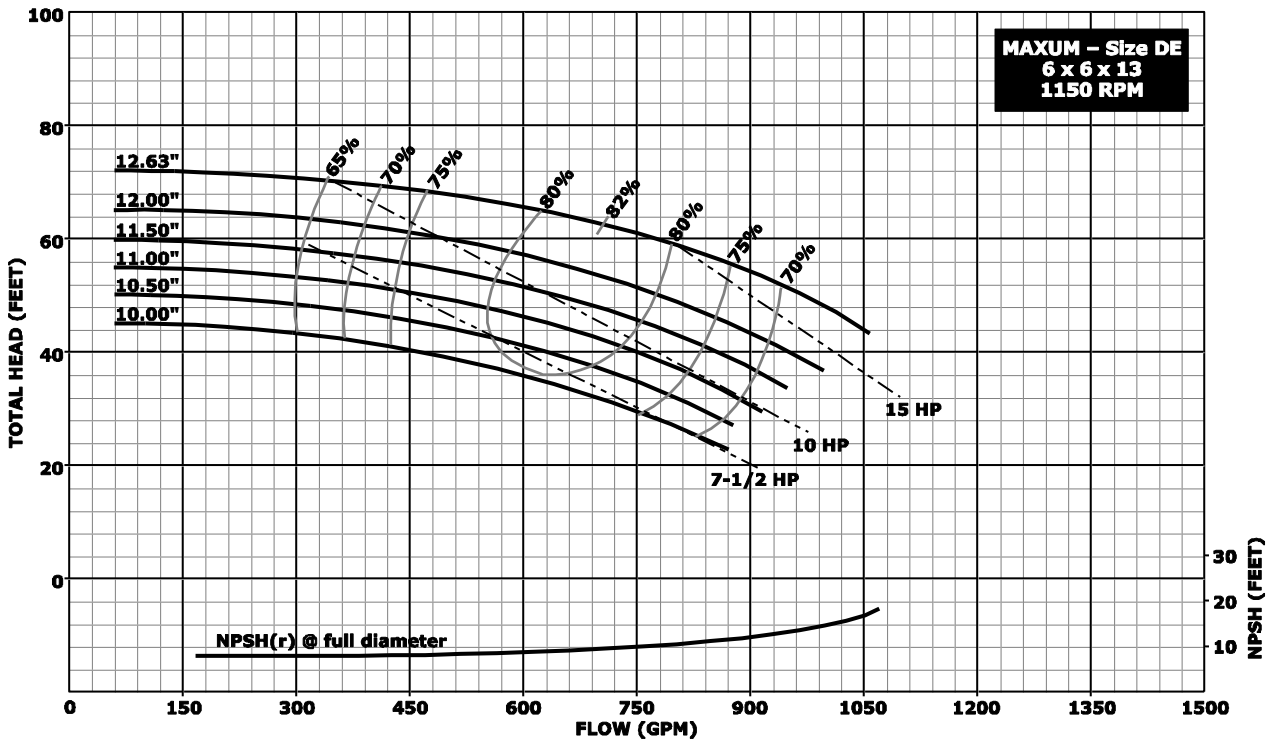
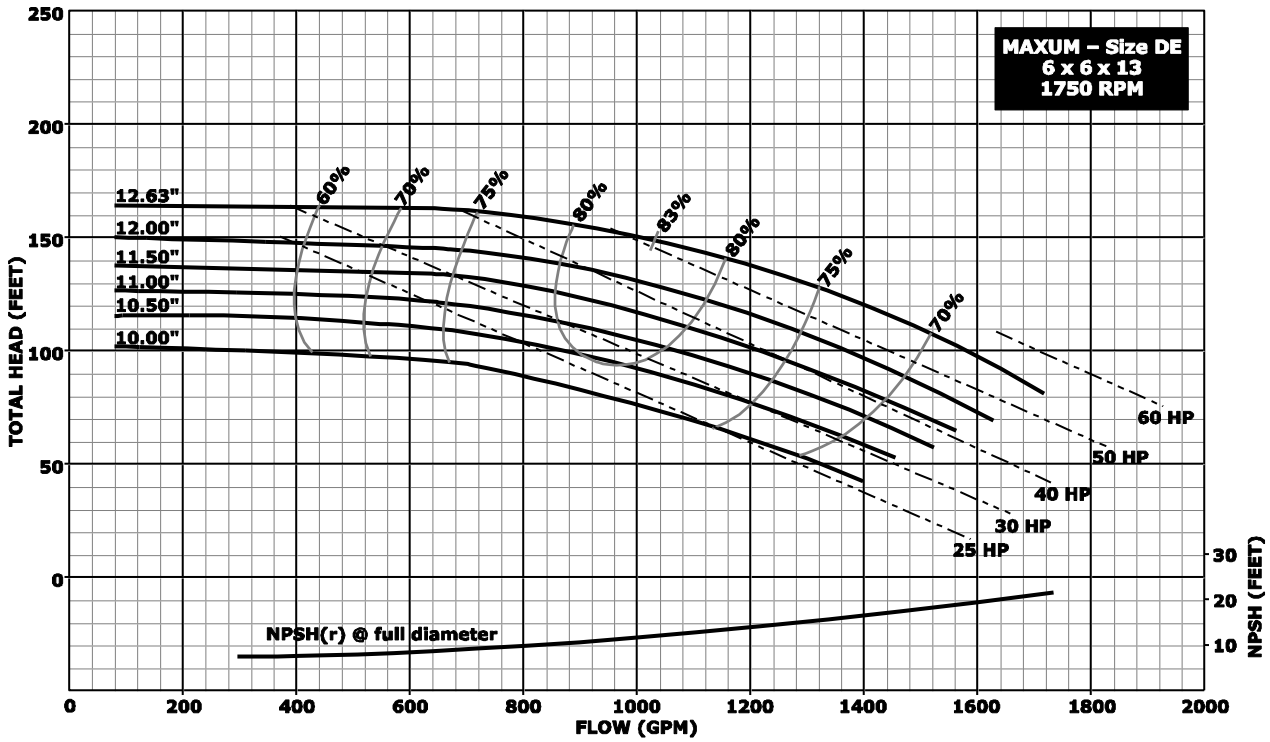

**Notes:**

1. Above data is based on 1.0 sp. gr. water at ambient temperature and pressure in accordance with Hydraulic Institute guidelines.
2. Impeller diameters between minimum and maximum shown are available in 1/8 inch increment trims.

Hydraulic Performance – 13” Impeller Pumps

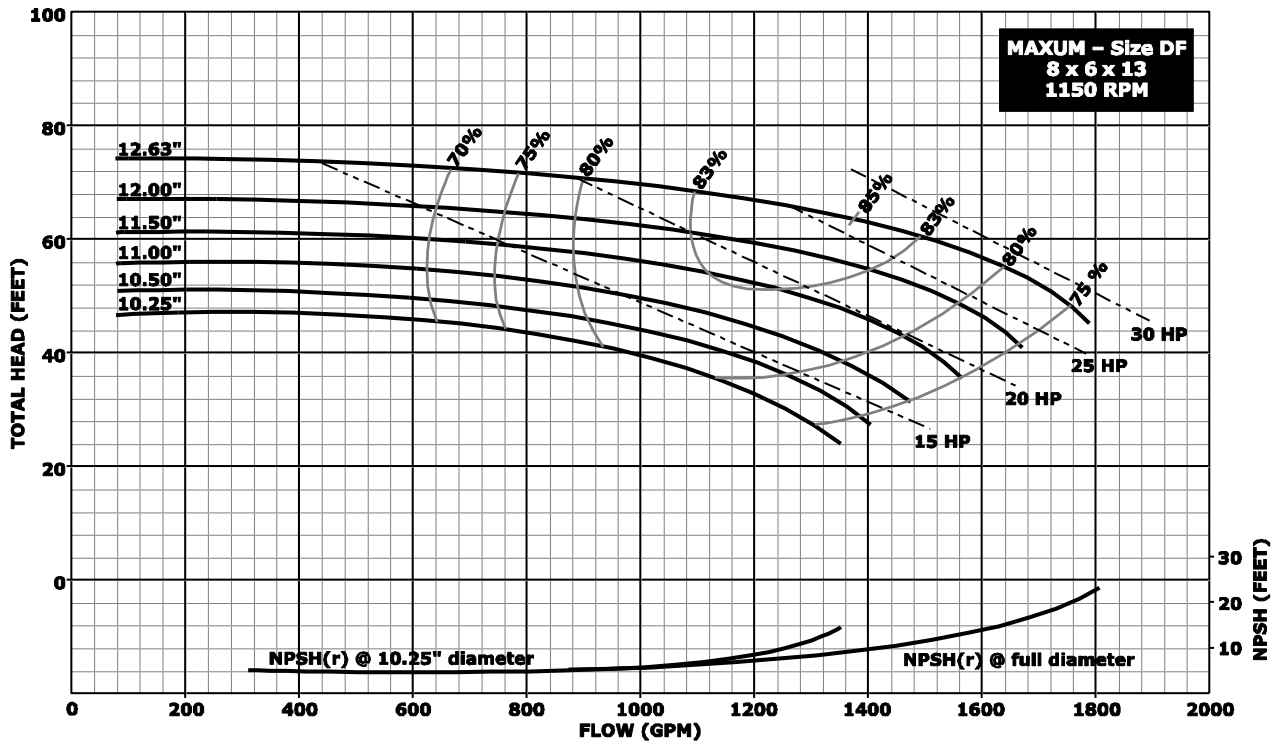
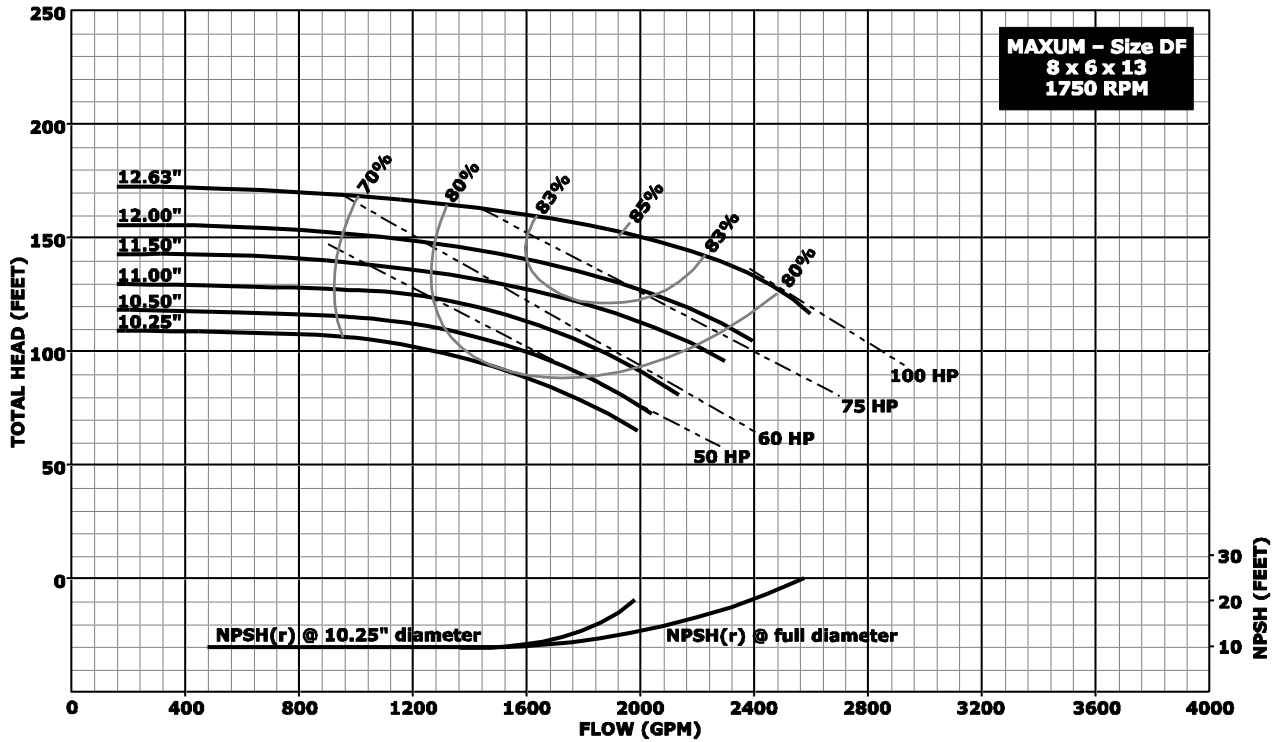

Notes:

1. Above data is based on 1.0 sp. gr. water at ambient temperature and pressure in accordance with Hydraulic Institute guidelines.
2. Impeller diameters between minimum and maximum shown are available in 1/8 inch increment trims.

### Hydraulic Performance – 13” Impeller Pumps

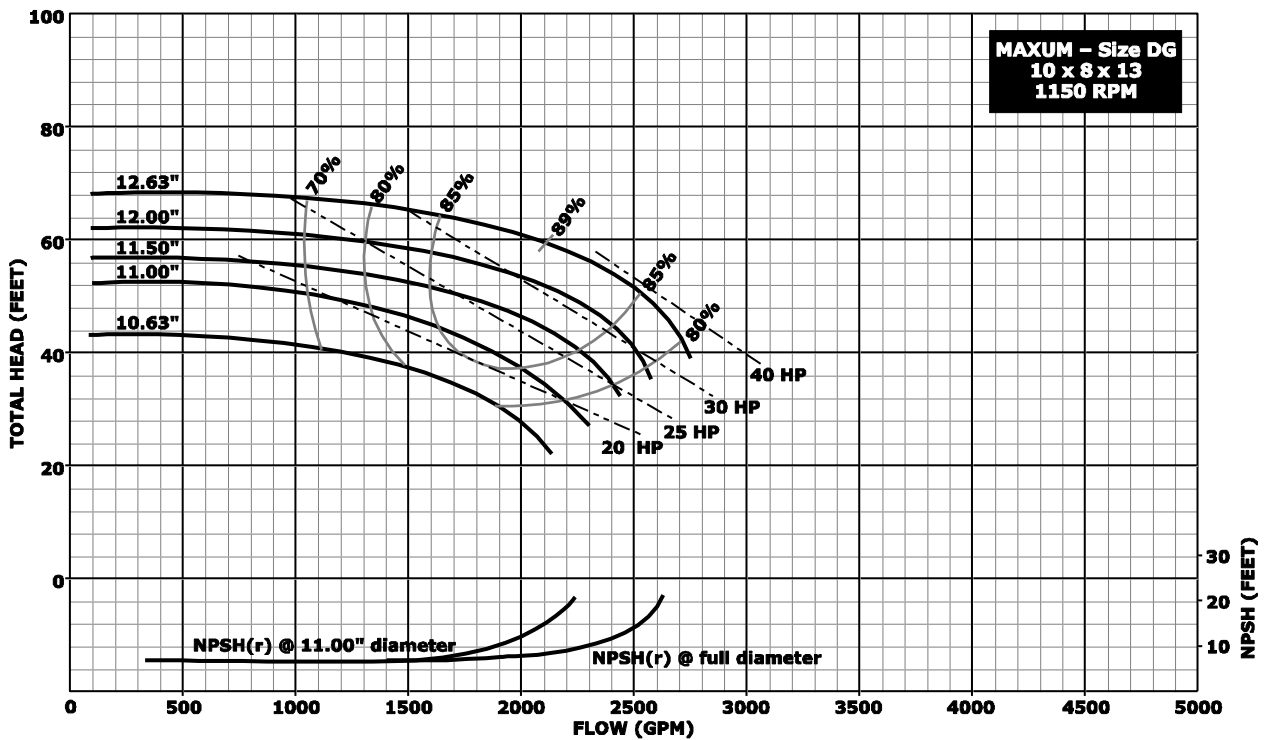
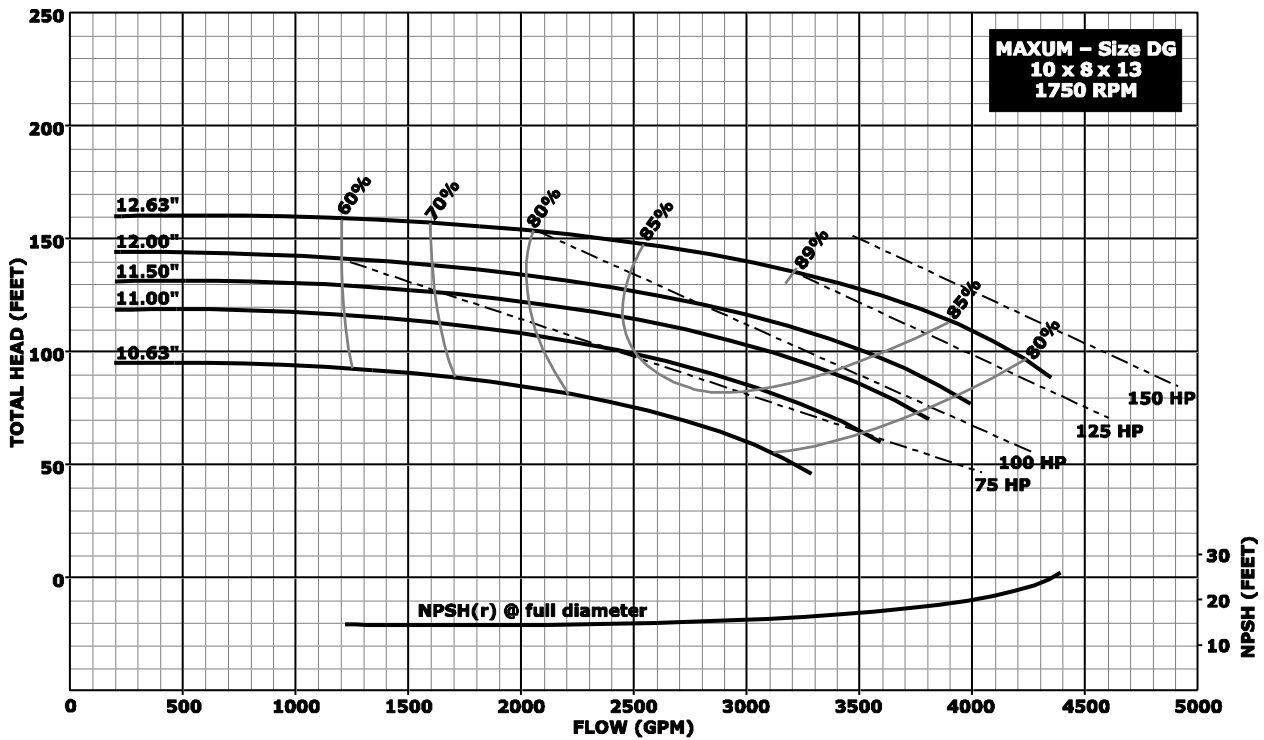

**Notes:**

1. Above data is based on 1.0 sp. gr. water at ambient temperature and pressure in accordance with Hydraulic Institute guidelines.
2. This is a mixed flow impeller pump, and trimming is accomplished by angular vane cuts. Impeller diameter trims shown are approximations only.

Hydraulic Performance – 13” Impeller Pumps

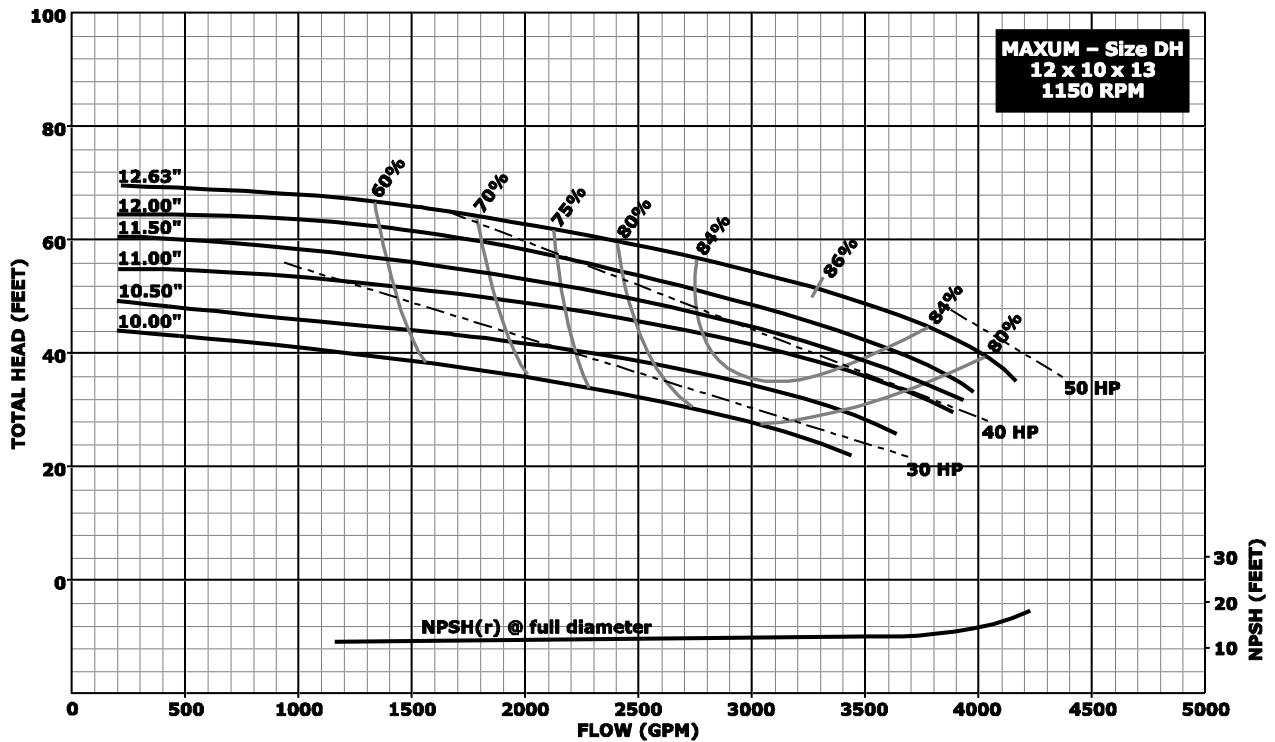
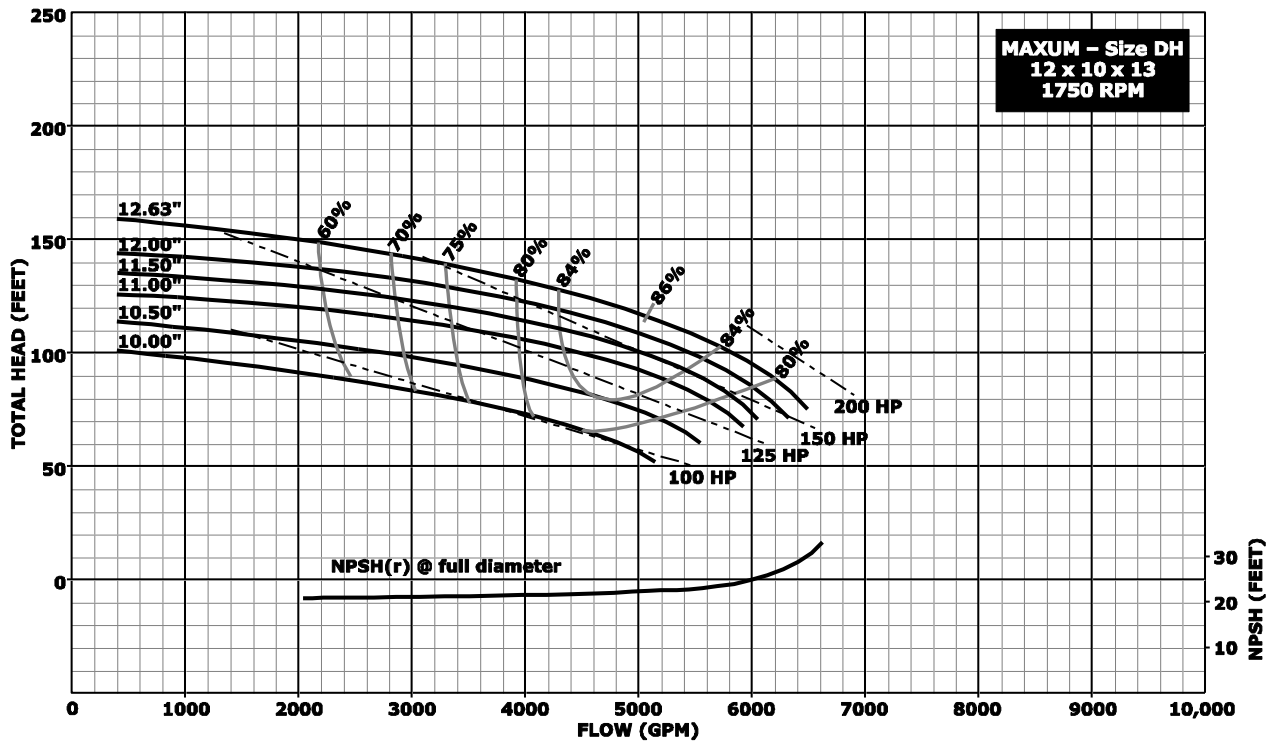

Notes:

1. Above data is based on 1.0 sp. gr. water at ambient temperature and pressure in accordance with Hydraulic Institute guidelines.
2. This is a mixed flow impeller pump, and trimming is accomplished by angular vane cuts. Impeller diameter trims shown are approximations only.

Hydraulic Performance – 16” Impeller Pumps

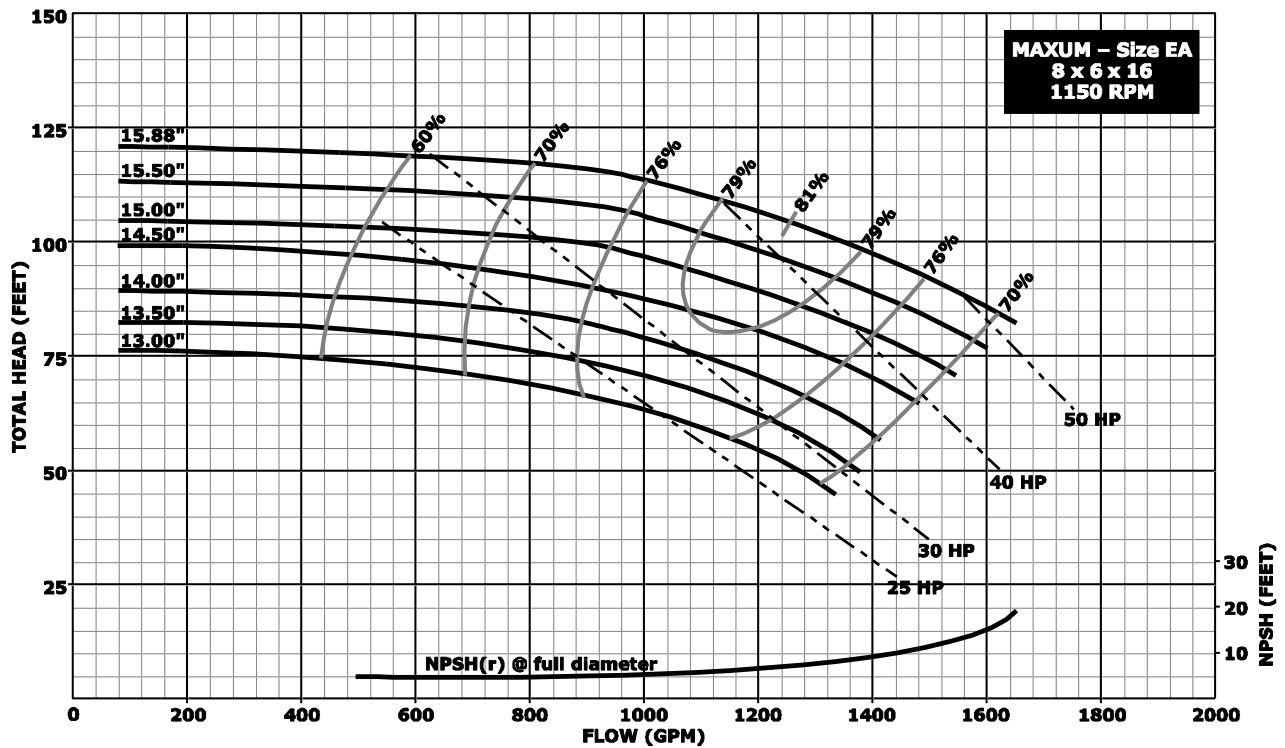
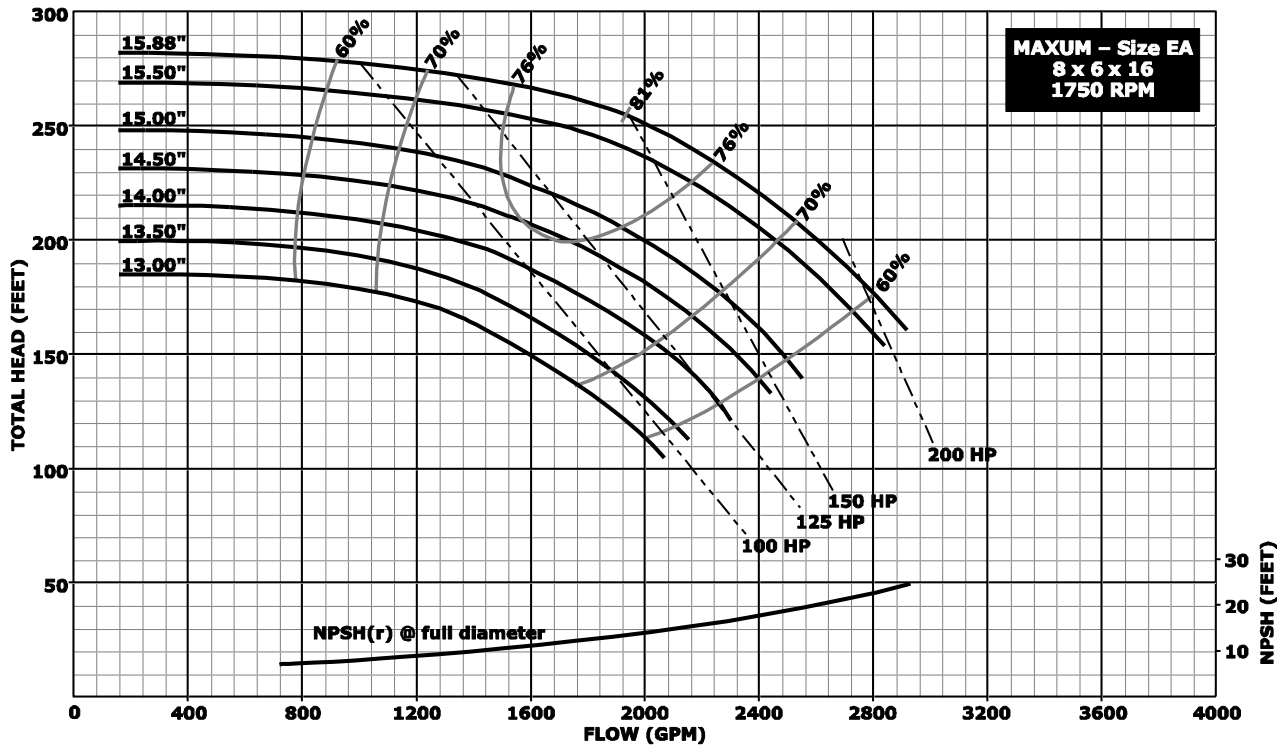

Notes:

1. Above data is based on 1.0 sp. gr. water at ambient temperature and pressure in accordance with Hydraulic Institute guidelines.
2. Impeller diameters between minimum and maximum shown are available in 1/8 inch increment trims.

Hydraulic Performance – 16” Impeller Pumps

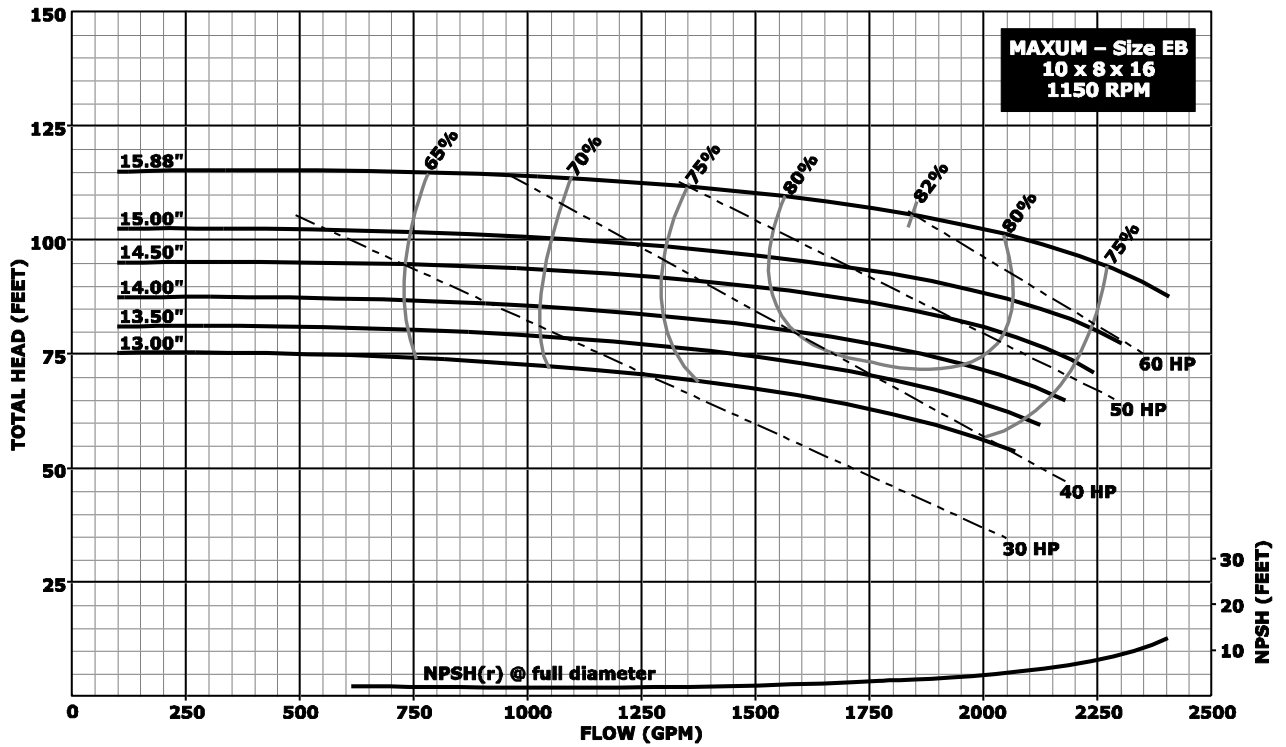
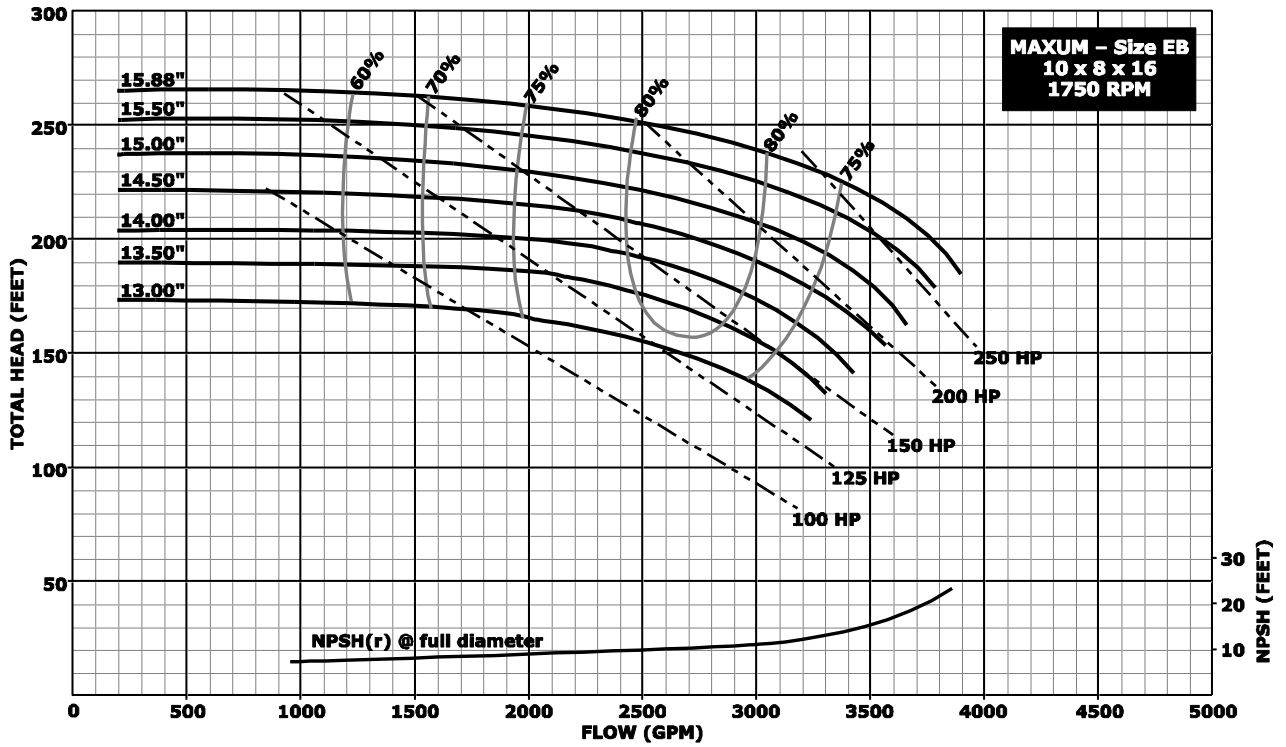

Notes:

1. Above data is based on 1.0 sp. gr. water at ambient temperature and pressure in accordance with Hydraulic Institute guidelines.
2. Impeller diameters between minimum and maximum shown are available in 1/8 inch increment trims.

Hydraulic Performance – 16” Impeller Pumps

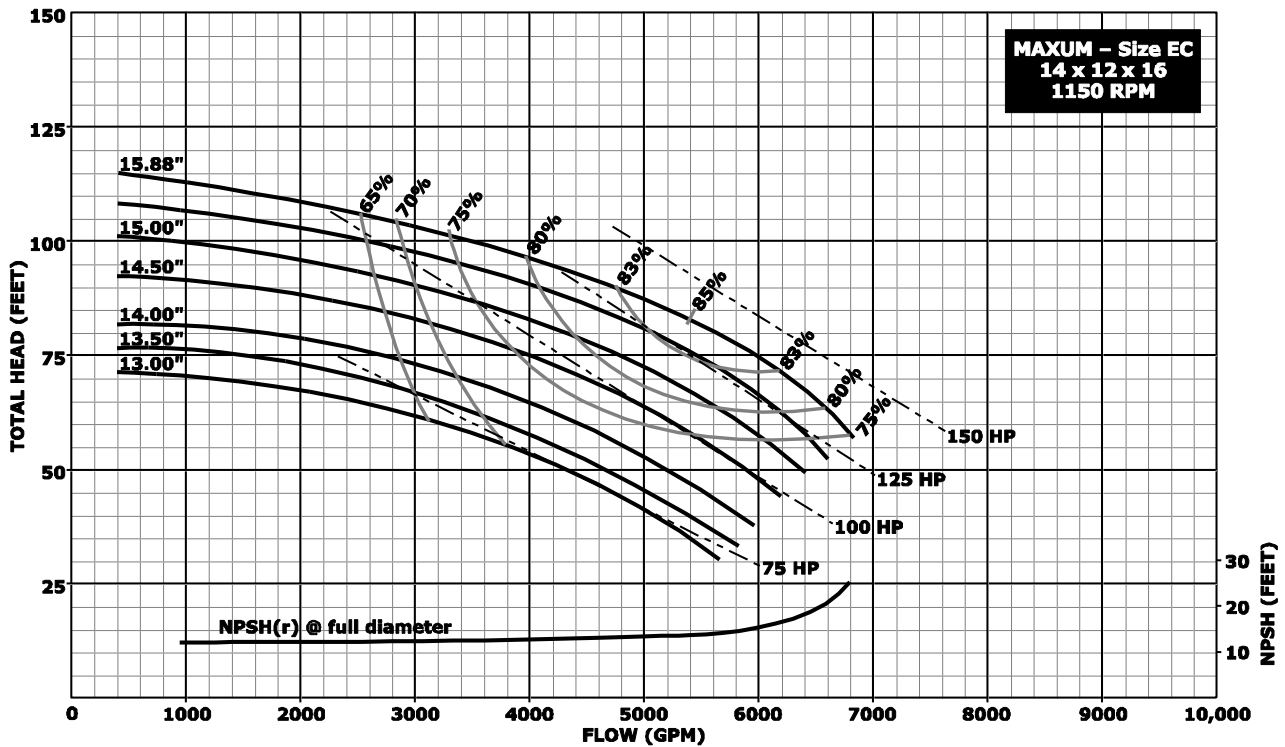
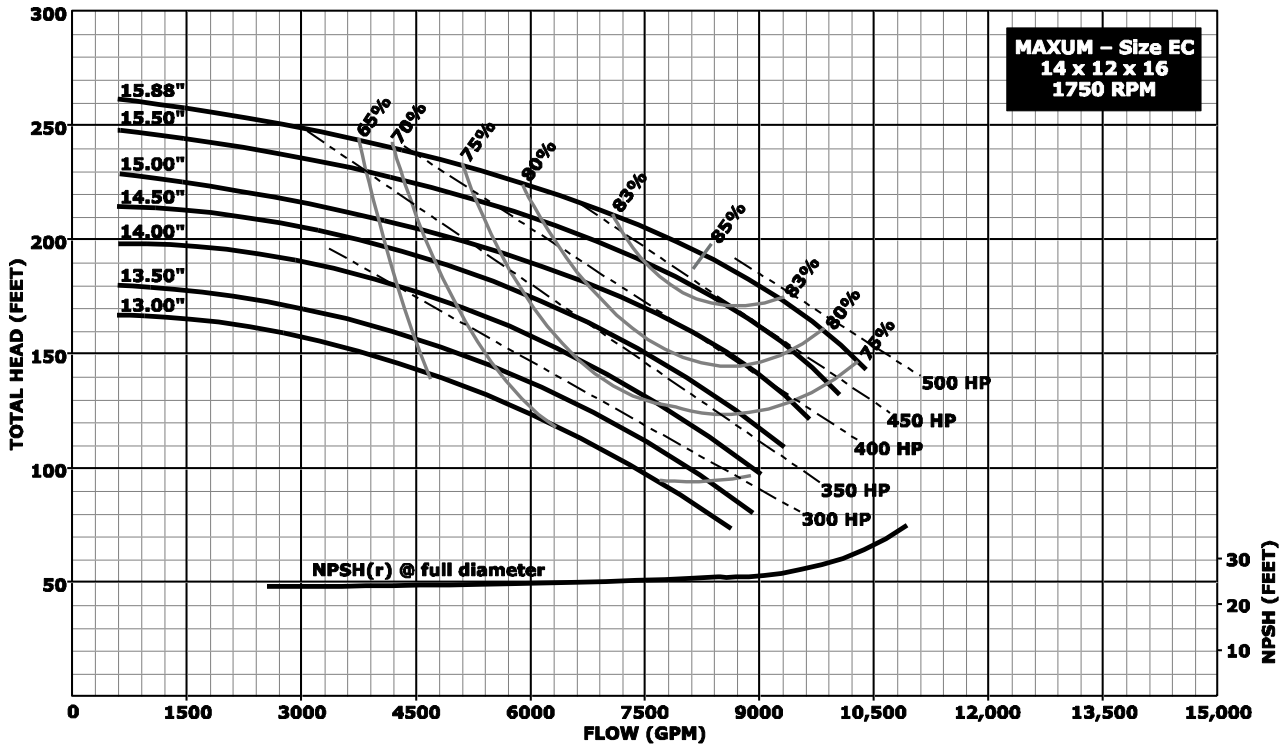

**Notes:**

1. Above data is based on 1.0 sp. gr. water at ambient temperature and pressure in accordance with Hydraulic Institute guidelines.
2. Impeller diameters between minimum and maximum shown are available in 1/8 inch increment trims.

Hydraulic Performance – 16” Impeller Pumps

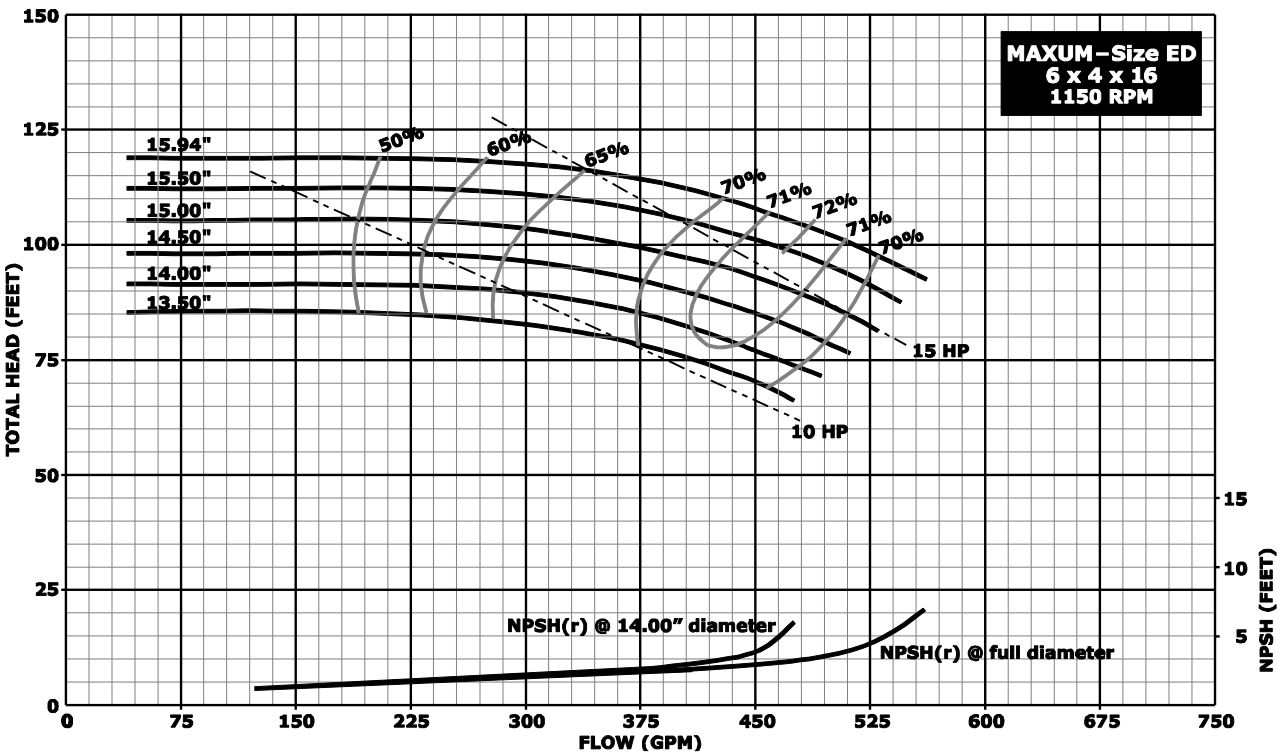
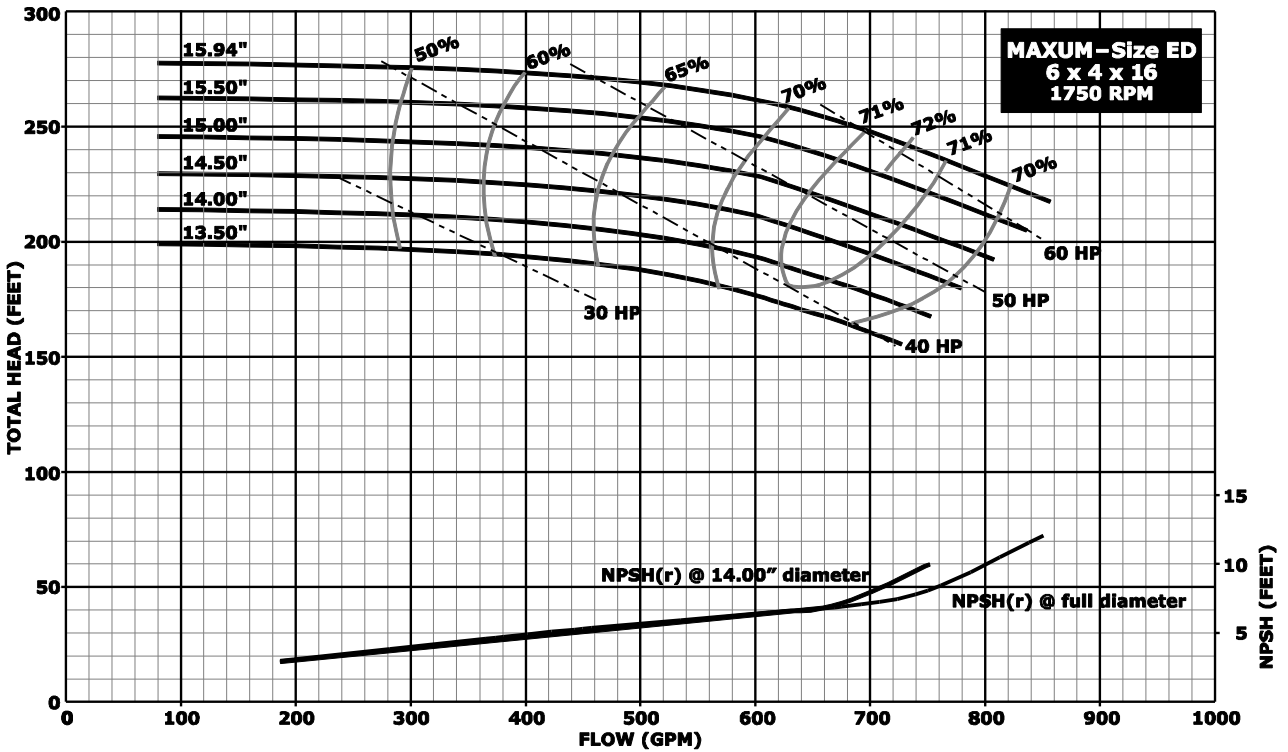

**Notes:**

1. Above data is based on 1.0 sp. gr. water at ambient temperature and pressure in accordance with Hydraulic Institute guidelines.
2. Impeller diameters between minimum and maximum shown are available in 1/8 inch increment trims.

Hydraulic Performance – 16" Impeller Pumps

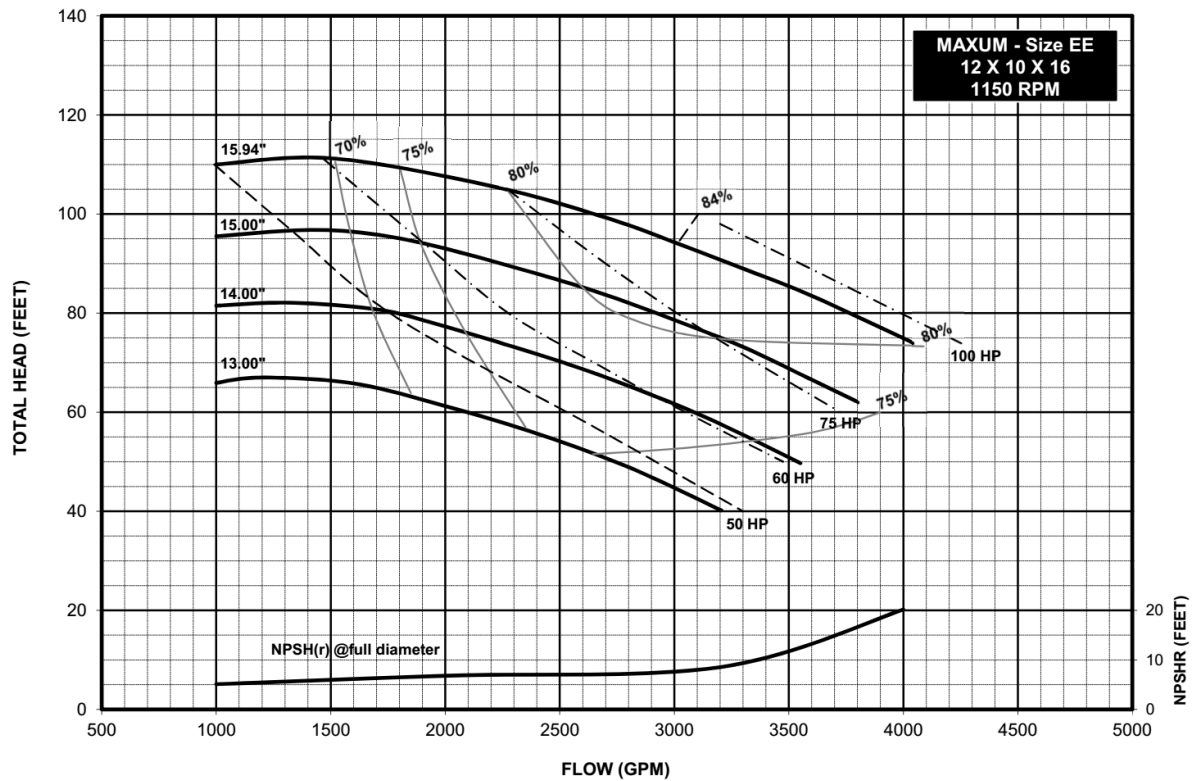
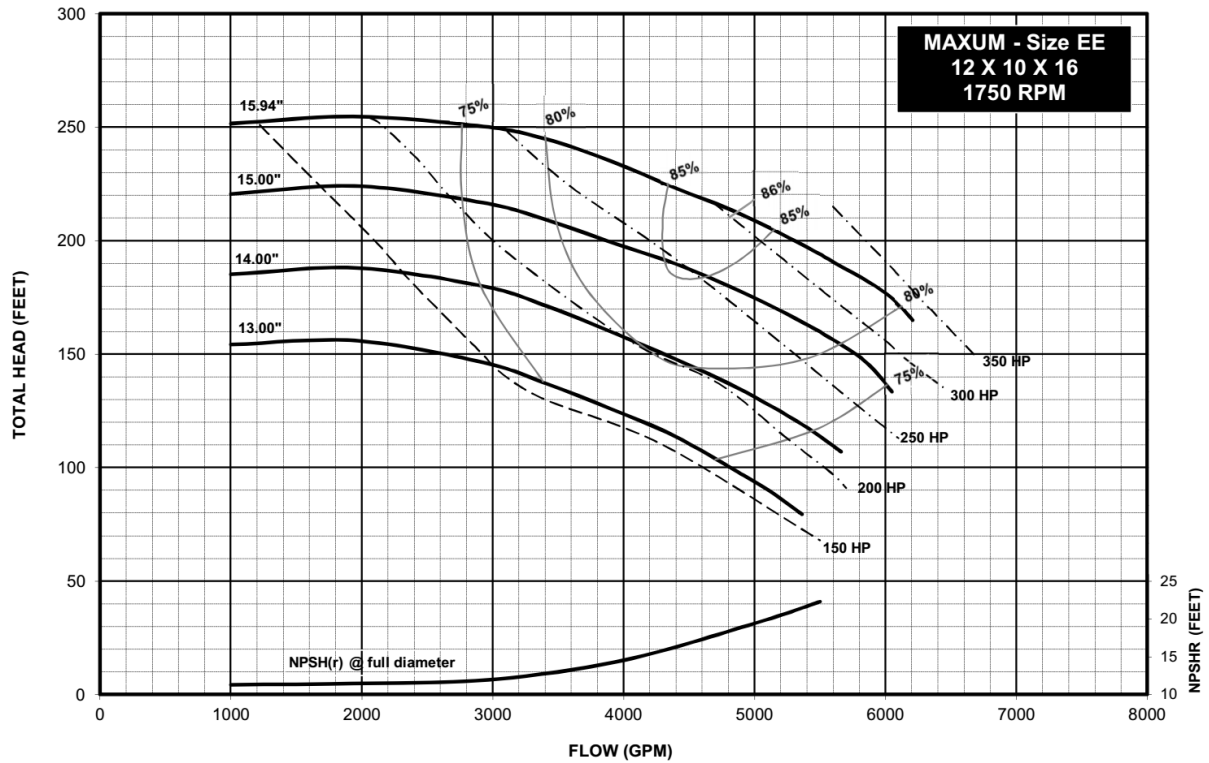

**Notes:**

1. Above data is based on 1.0 sp. gr. water at ambient temperature and pressure in accordance with Hydraulic Institute guidelines.
2. This is a mixed flow impeller pump, and trimming is accomplished by angular vane cuts. Impeller diameter trims shown are approximations only.

Hydraulic Performance – 20” Impeller Pumps

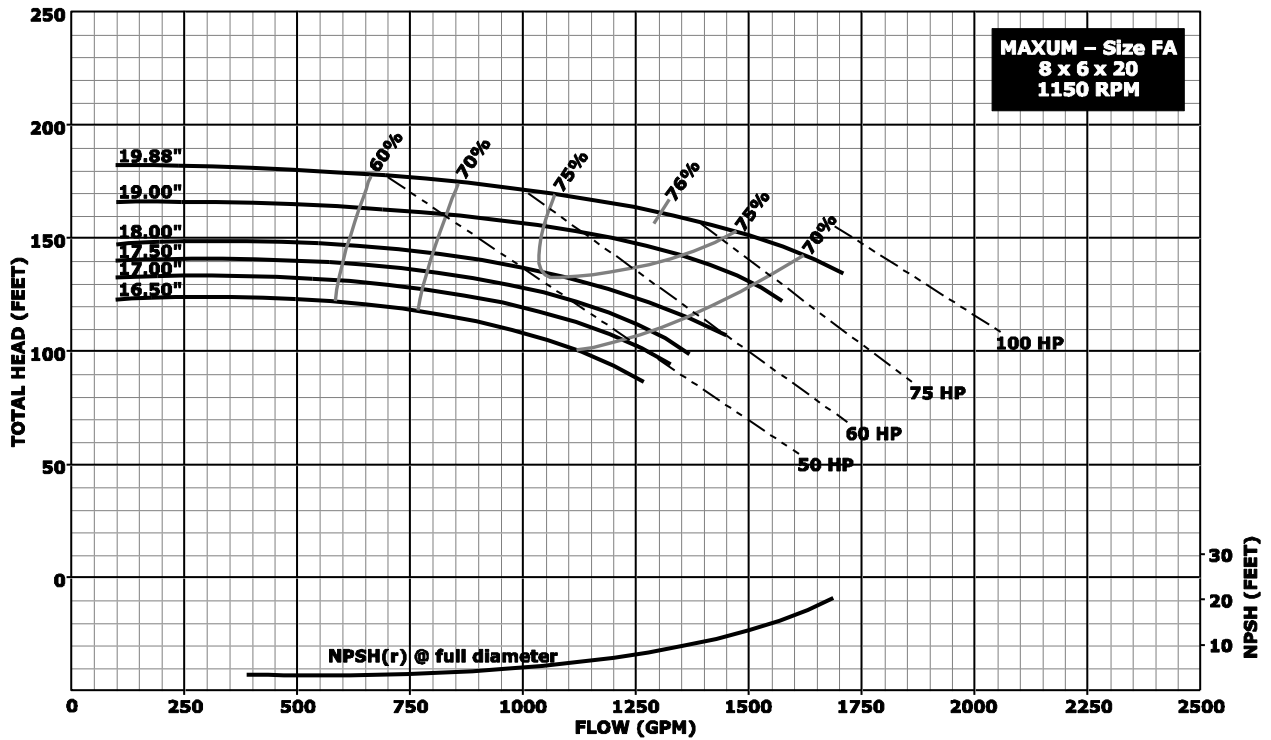
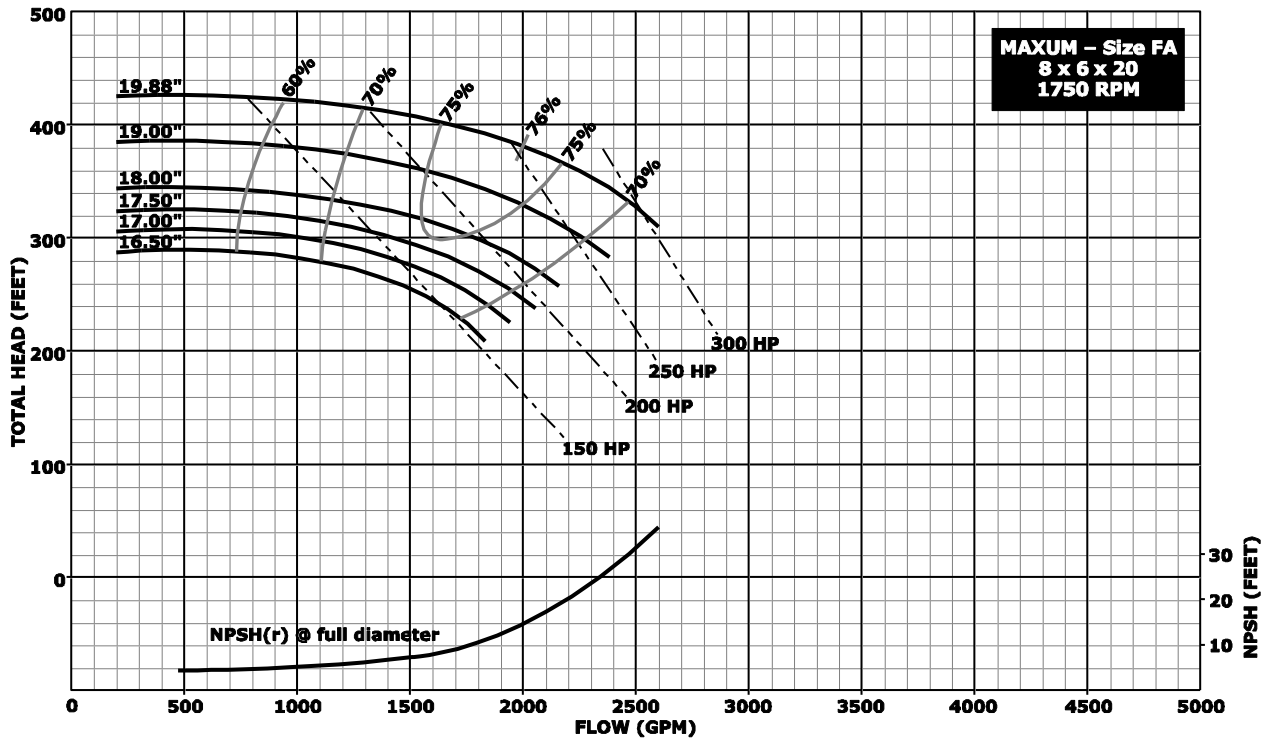

**Notes:**

1. Above data is based on 1.0 sp. gr. water at ambient temperature and pressure in accordance with Hydraulic Institute guidelines.
2. Impeller diameters between minimum and maximum shown are available in 1/8 inch increment trims.

Hydraulic Performance – 20” Impeller Pumps

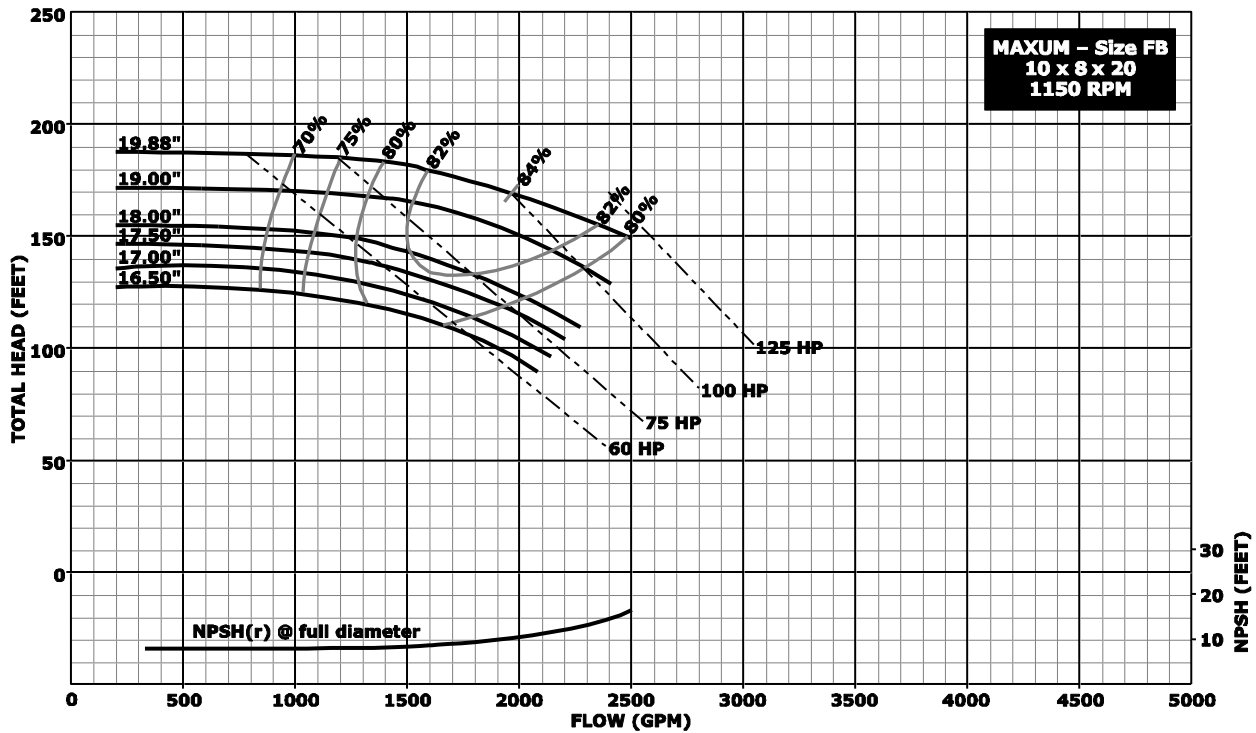
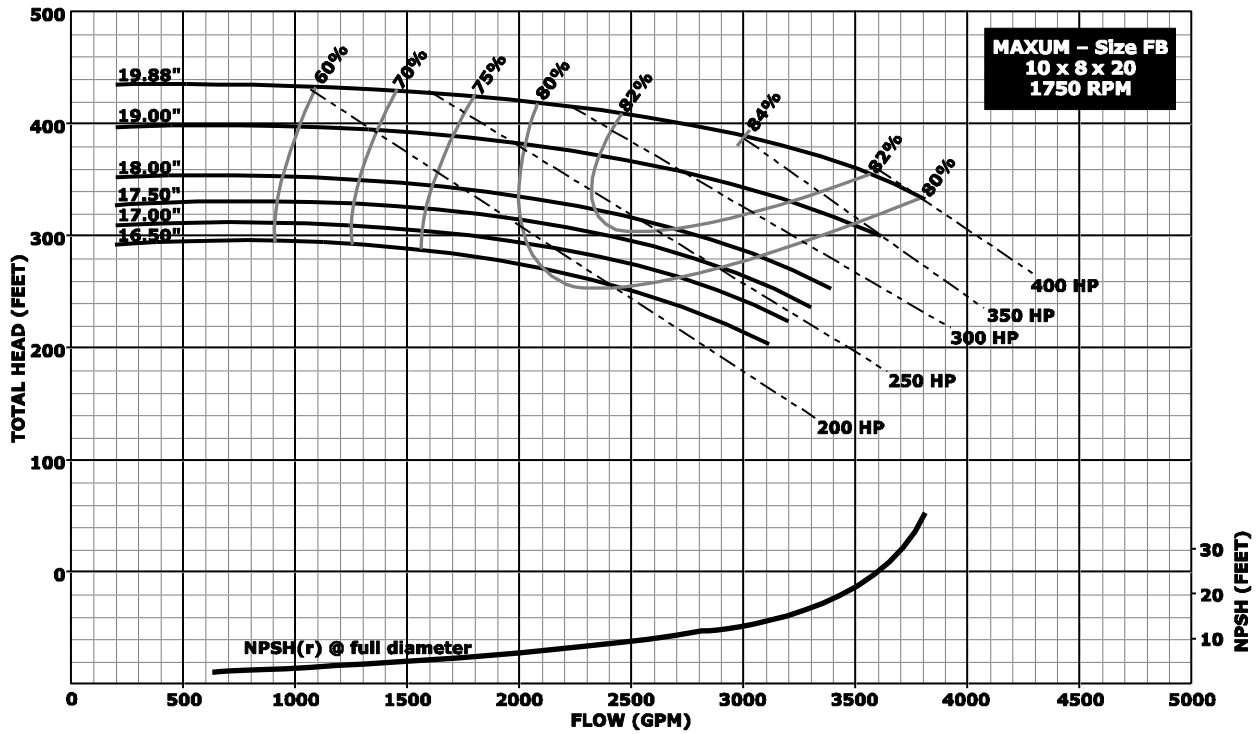

Notes:

1. Above data is based on 1.0 sp. gr. water at ambient temperature and pressure in accordance with Hydraulic Institute guidelines.
2. Impeller diameters between minimum and maximum shown are available in 1/8 inch increment trims.

Hydraulic Performance –20” Impeller Pumps

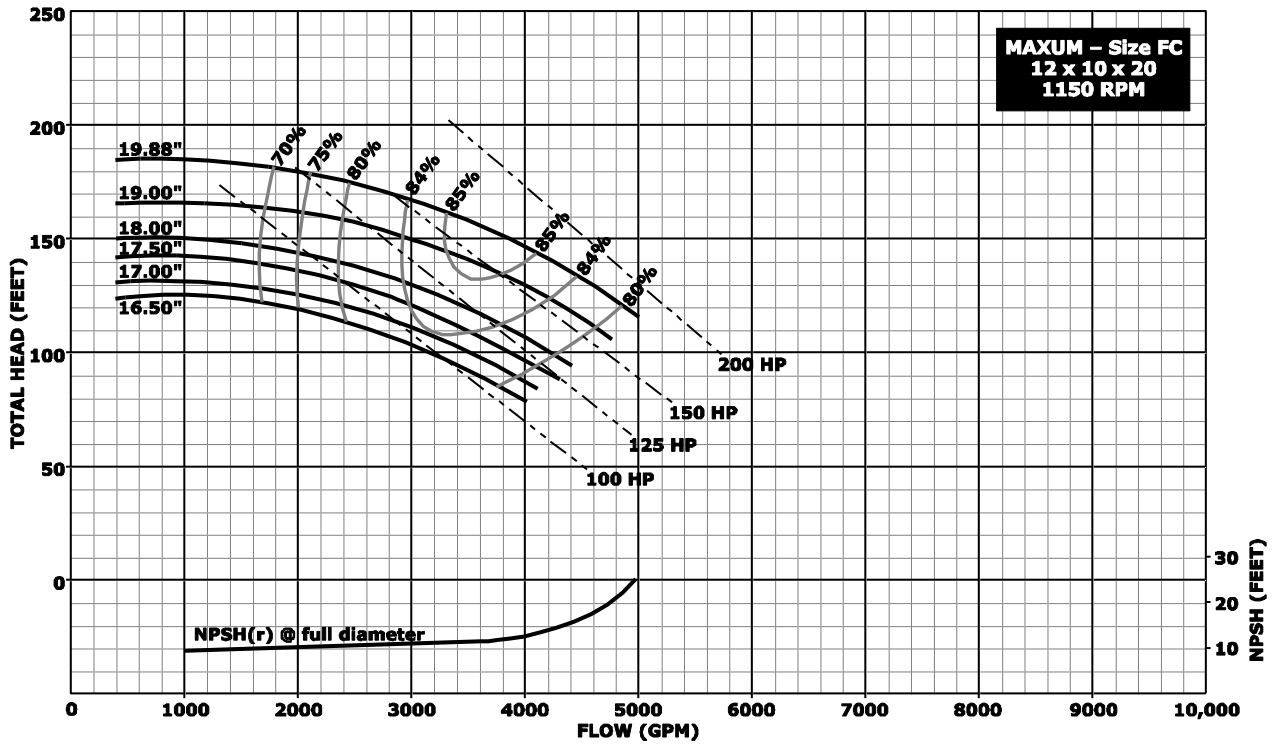
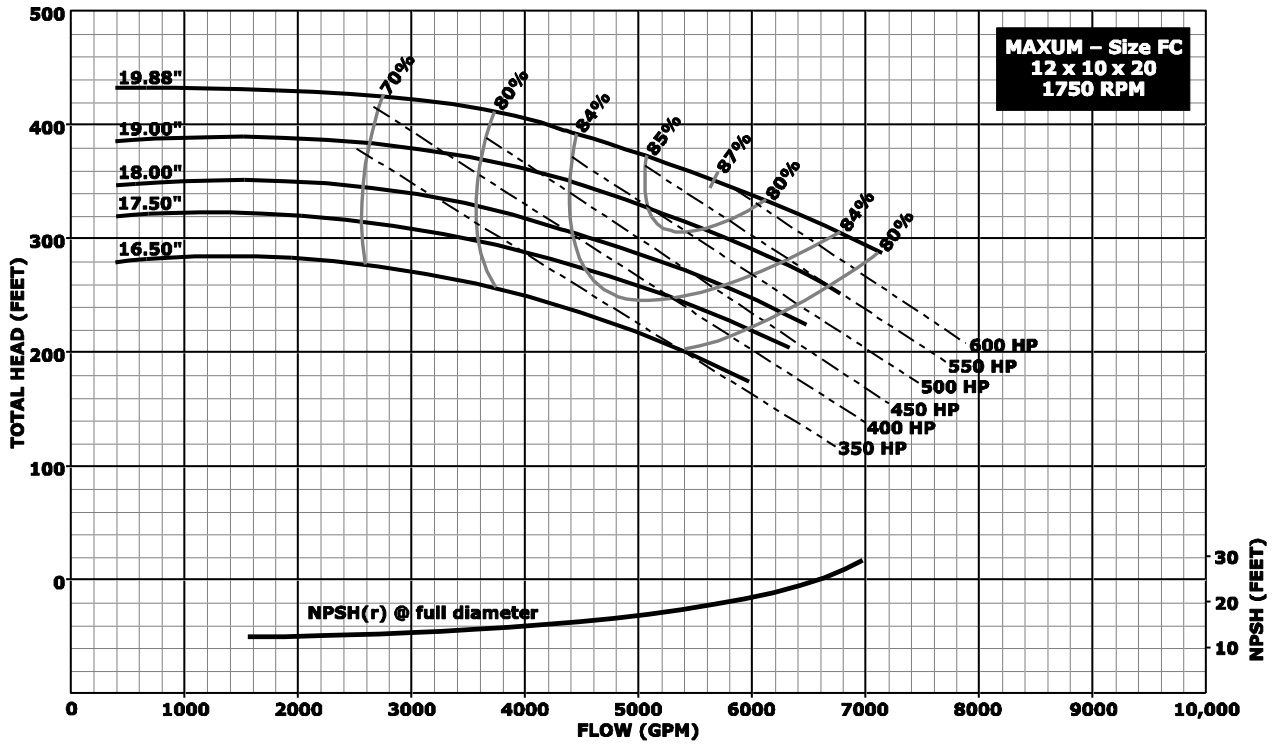

Notes:

1. Above data is based on 1.0 sp. gr. water at ambient temperature and pressure in accordance with Hydraulic Institute guidelines.
2. Impeller diameters between minimum and maximum shown are available in 1/8 inch increment trims.

Hydraulic Performance – 20” Impeller Pumps

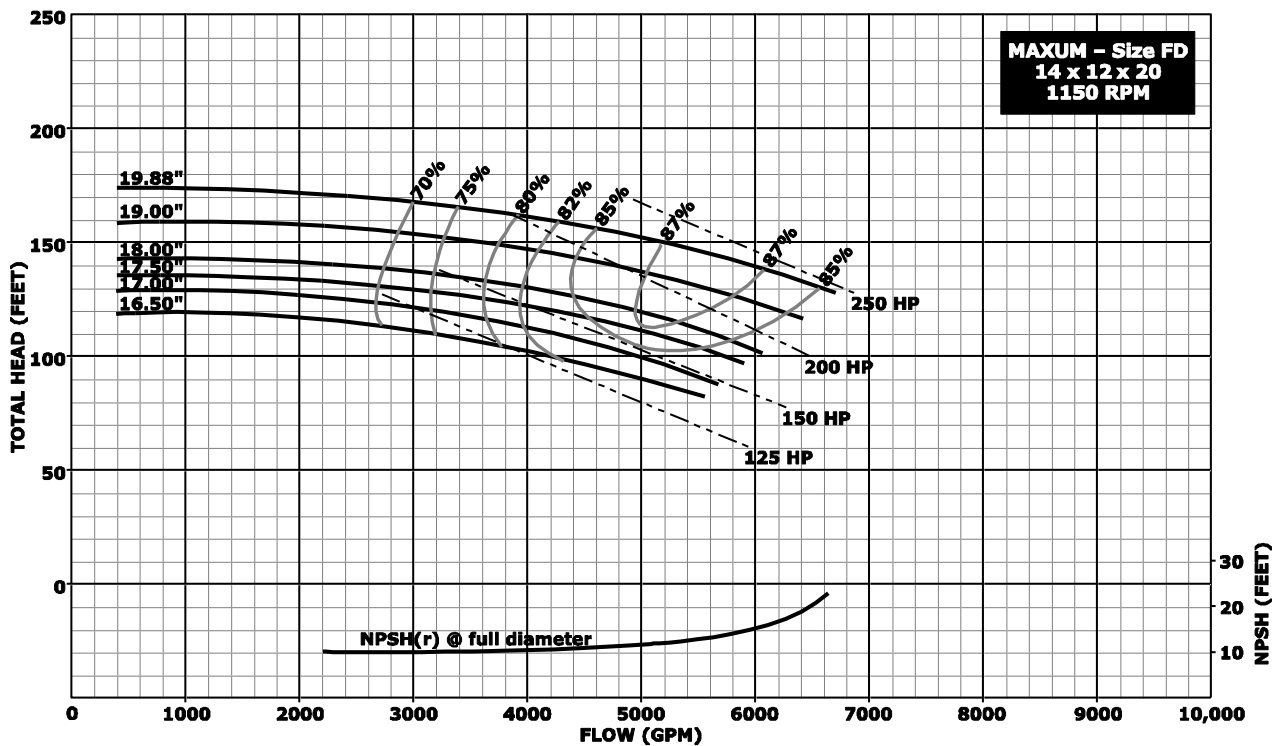
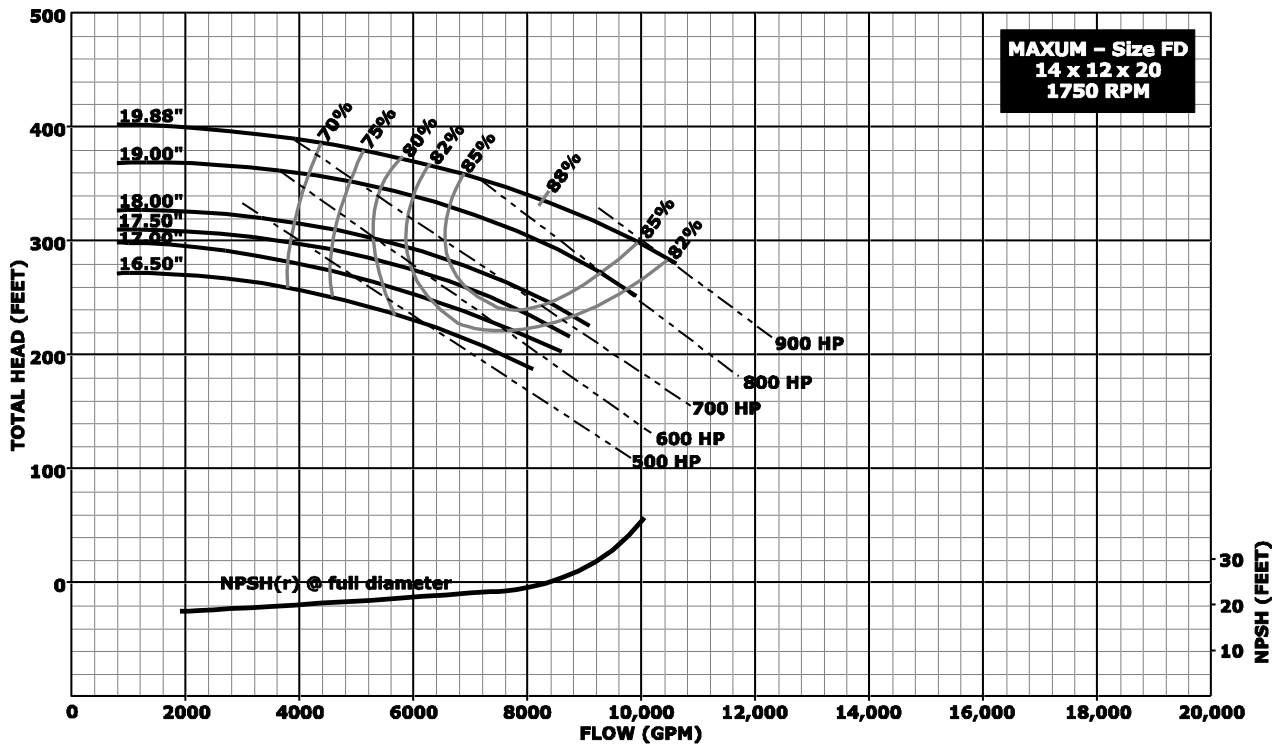

**Notes:**

1. Above data is based on 1.0 sp. gr. water at ambient temperature and pressure in accordance with Hydraulic Institute guidelines.
2. This is a mixed flow impeller pump, and trimming is accomplished by angular vane cuts. Impeller diameter trims shown are approximations only.

Permissible Nozzle Loads

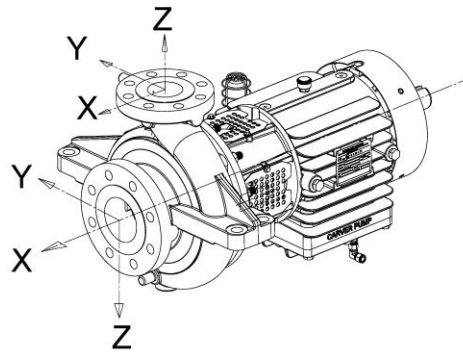

Pump Size	Suction						Discharge					
	Fx	Fy	Fz	Mx	My	Mz	Fx	Fy	Fz	Mx	My	Mz
AA- 1½ x 1 x 6	200	160	130	340	170	260	160	130	200	340	170	200
AB - 2 x 1½ x 6	200	160	130	340	170	260	160	130	200	340	170	200
AC- 3 x 1½ x 6	300	240	200	700	350	530	160	130	200	340	170	200
AD - 3 x 2 x 6	300	240	200	700	350	530	160	130	200	340	170	200
AE - 4 x 3 x 6	400	320	260	980	500	740	240	200	300	700	350	530
BA - 1½ x 1 x 8	200	160	130	340	170	260	160	130	200	340	170	200
BB - 2 x 1½ x 8	200	160	130	340	170	260	160	130	200	340	170	200
BC - 3 x 1½ x 8	300	240	200	700	350	530	160	130	200	340	170	200
BD - 3 x 2 x 8	300	240	200	700	350	530	160	130	200	340	170	200
BE - 4 x 3 x 8	400	320	260	980	500	740	240	200	300	700	350	530
BF - 6 x 4 x 8	700	560	460	1700	870	1,300	320	260	400	980	500	740
CA - 2 x 1½ x 10	200	160	130	340	170	260	160	130	200	340	170	200
CB - 3 x 1½ x 10	300	240	200	700	350	530	160	130	200	340	170	200
CC - 3 x 2 x 10	300	240	200	700	350	530	160	130	200	340	170	200
CD - 4 x 3 x 10	400	320	260	980	500	740	240	200	300	700	350	530
CE - 6 x 4 x 10	700	560	460	1700	870	1,300	320	260	400	980	500	740
CF - 6 x 6 x 10	700	560	460	1700	870	1,300	560	460	700	1700	870	1300
CG - 8 x 6 x 10	1100	850	700	2600	1,300	1,900	560	460	700	1700	870	1300
DA - 2 x 1½ x 13	200	160	130	340	170	260	160	130	200	340	170	200
DB - 3 x 2 x 13	300	240	200	700	350	530	160	130	200	340	170	200
DC - 4 x 3 x 13	400	320	260	980	500	740	240	200	300	700	350	530
DD - 6 x 4 x 13	700	560	460	1700	870	1,300	320	260	400	980	500	740
DE - 6 x 6 x 13	700	560	460	1700	870	1,300	560	460	700	1700	870	1300
DF - 8 x 6 x 13	1100	850	700	2600	1,300	1,900	560	460	700	1700	870	1300
DG - 10 x 8 x 13	1500	1200	1000	3700	1800	2800	850	700	1100	2600	1,300	1,900
DH - 12 x 10 x 13	1800	1500	1200	4500	2200	3400	1200	1000	1500	3700	1800	2800
ED- 6 x 4 x 16	700	560	460	1700	870	1,300	320	260	400	980	500	740
EA- 8 x 6 x 16	1100	850	700	2600	1,300	1,900	560	460	700	1700	870	1300
EB - 10 x 8 x 16	1500	1200	1000	3700	1800	2800	850	700	1100	2600	1,300	1,900
EE - 12 x 10 x 16	1800	1500	1200	4500	2200	3400	1200	1000	1500	3700	1800	2800
EC - 14 x 12 x 16	2000	1600	1300	4700	2300	6300	1,500	1200	1800	4500	2200	3400
FA - 8 x 6 x 20	1100	850	700	2600	1,300	1,900	560	460	700	1700	870	1300
FB - 10 x 8 x 20	1500	1200	1000	3700	1800	2,870	850	700	1100	2600	1,300	1,900
FC - 12 x 10 x 20	1800	1500	1200	4500	2200	3400	1200	1000	1500	3700	1800	2800
FD - 14 x 12 x 20	2000	1600	1300	4700	2300	6300	1,500	1200	1800	4500	2200	3400

M = Moments measured in Foot-Pounds (FT-lbs)

F = Forces measured in Pounds (lbs)

	<ol style="list-style-type: none"> <li>1. All force values in lbs. All moment values in ft.-lbs.</li> <li>2. All moment values in ft.-lbs.</li> <li>3. Not valid for construction unless certified.</li> </ol>	<p><b>Dwg: SP-API-1, Rev: 0</b></p>
---	--	-------------------------------------

### Bare Pump Dimensions

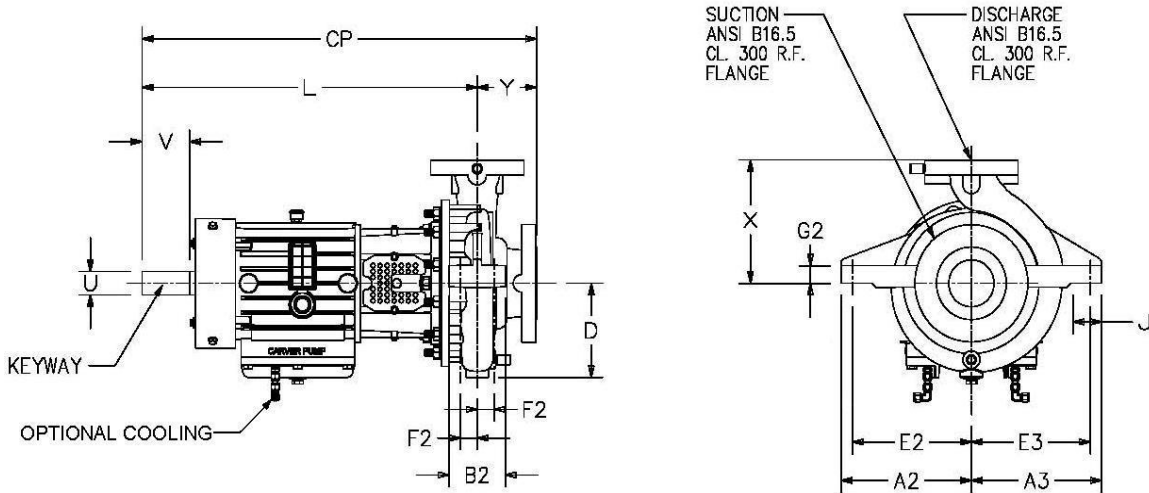

Pump Size	Pump Dimensions																
	X	Y	CP	A2	A3	B2	D	E2	E3	F2	G2	H	J	L	U	V	Keyway
1½ x 1 x 6	6.50	4.00	27.92	8.13	8.13	4.50	4.5	7.25	7.25	1.50	1.50	0.75	2.00	23.92	1.38	3.25	0.313 x 0.157
2 x 1½ x 6	6.50	4.38	28.29	8.13	8.13	4.50	4.75	7.25	7.25	1.50	1.50	0.75	2.00	23.92	1.38	3.25	0.313 x 0.157
3 x 1½ x 6	6.50	4.00	27.92	8.13	8.13	4.50	5.25	7.25	7.25	1.50	1.50	0.75	2.00	23.92	1.38	3.25	0.313 x 0.157
3 x 2 x 6	8.25	4.00	27.92	8.13	8.13	4.50	5.5	7.25	7.25	1.50	1.50	0.75	2.00	23.92	1.38	3.25	0.313 x 0.157
4 x 3 x 6	11.00	5.13	29.28	10.0	10.0	5.50	6.88	9.00	9.00	1.75	1.50	0.88	2.13	24.15	1.38	3.25	0.313 x 0.157
1½ x 1 x 8	8.00	4.00	28.14	8.75	8.75	4.50	5.75	7.88	7.88	1.50	1.50	0.75	2.00	24.14	1.38	3.25	0.313 x 0.157
2 x 1½ x 8	8.00	4.38	28.54	8.75	8.75	4.50	5.6	7.88	7.88	1.50	1.50	0.75	2.00	24.17	1.38	3.25	0.313 x 0.157
3 x 1½ x 8	8.50	4.00	28.19	8.75	8.75	4.50	6.25	7.88	7.88	1.50	1.50	0.75	2.00	24.19	1.38	3.25	0.313 x 0.157
3 x 2 x 8	9.50	4.00	28.23	8.75	8.75	4.50	6.25	7.88	7.88	1.50	1.50	0.75	2.00	24.23	1.38	3.25	0.313 x 0.157
4 x 3 x 8	11.00	5.25	29.56	9.87	9.87	5.13	7.3	9.00	9.00	1.75	1.50	0.88	2.13	24.31	1.38	3.25	0.313 x 0.157
6 x 4 x 8	11.25	5.50	30.17	11.50	11.50	5.50	7.75	10.5	10.5	2.00	1.50	0.88	2.50	24.67	1.38	3.25	0.313 x 0.157
2 x 1½ x 10	9.06	4.36	33.73	9.00	9.00	4.50	6.6	8.38	8.38	1.50	1.25	0.75	1.88	26.62	2.00	4.88	0.500 x 0.250
3 x 1½ x 10	8.88	5.00	34.51	9.00	9.00	4.50	6.75	8.38	8.38	1.50	0.75	0.75	1.88	29.51	2.00	4.88	0.500 x 0.250
3 x 2 x 10	9.50	5.13	34.57	9.00	9.00	4.50	7.0	8.38	8.38	1.50	1.50	0.75	1.88	29.44	2.00	4.88	0.500 x 0.250
4 x 3 x 10	10.50	5.25	34.85	11.50	11.50	5.00	8.0	10.50	10.50	1.50	1.50	1.00	2.75	29.60	2.00	4.88	0.500 x 0.250
6 x 4 x 10	11.50	5.88	35.61	14.00	14.00	6.00	8.8	12.50	12.50	2.00	1.50	0.88	3.50	29.73	2.00	4.88	0.500 x 0.250
6 x 6 x 10	15.13	6.88	36.80	15.50	15.50	7.25	9.75	14.00	14.00	2.50	2.00	1.00	3.00	29.93	2.00	4.88	0.500 x 0.250
8 x 6 x 10	15.00	6.63	36.90	15.50	15.50	7.25	10.75	14.50	14.50	2.56	2.00	1.00	3.25	30.27	2.00	4.88	0.500 x 0.250
2 x 1½ x 13	10.00	5.00	34.66	10.00	10.00	5.00	7.8	9.00	9.00	1.50	0.75	0.75	2.13	29.66	2.00	4.88	0.500 x 0.250
3 x 2 x 13	11.00	5.10	34.80	11.50	11.50	5.00	8.0	10.25	10.25	1.50	1.50	0.88	2.63	29.70	2.00	4.88	0.500 x 0.250
4 x 3 x 13	13.63	5.50	35.27	12.50	12.50	5.00	8.5	11.00	11.00	1.50	1.50	0.88	3.25	29.77	2.00	4.88	0.500 x 0.250
6 x 4 x 13	14.00	6.00	35.97	15.00	15.00	7.25	9.75	13.88	13.88	2.50	1.50	0.88	3.25	29.97	2.00	4.88	0.500 x 0.250
6 x 6 x 13	16.13	7.52	37.53	15.50	15.50	7.25	10.7	14.25	14.25	2.50	2.00	1.00	3.50	30.01	2.00	4.88	0.500 x 0.250
8 x 6 x 13	16.25	6.75	37.16	15.50	15.50	7.25	11.25	14.25	14.25	2.50	2.00	1.00	3.00	30.41	2.00	4.88	0.500 x 0.250
10 x 8 x 13	18.50	8.50	39.07	17.50	17.50	8.00	13.0	16.00	16.00	2.75	2.00	1.13	3.50	30.57	2.00	4.88	0.500 x 0.250
12 x 10 x 13	22.50	10.5	41.60	22.50	22.50	10.0	15.5	21.00	21.00	3.50	2.00	1.13	3.50	31.10	2.00	4.88	0.500 x 0.250
6 x 4 x 16	16.50	7.00	46.17	16.50	16.50	9.00	11.75	15.00	15.00	3.00	2.00	1.13	3.50	39.17	3.00	8.19	0.750 x 0.375
8 x 6 x 16	17.75	7.00	49.71	16.75	16.75	6.00	12.4	15.50	15.50	2.00	2.00	0.88	2.50	42.71	3.00	8.19	0.750 x 0.375
10 x 8 x 16	20.25	7.50	46.89	21.00	21.00	10.00	13.6	19.50	19.50	3.50	2.00	1.06	4.00	39.39	3.00	8.19	0.750 x 0.375
12 x 10 x 16	23.62	9.38	49.71	23.00	23.00	10.25	16.5	21.50	21.50	3.25	2.25	1.13	4.00	40.33	3.00	8.19	0.750 x 0.375
14 x 12 x 16	26.00	12.0	52.18	21.00	26.88	11.00	19.6	19.00	24.88	4.00	2.75	1.38	4.00	40.18	3.00	8.19	0.750 x 0.375
8 x 6 x 20	19.75	7.25	47.15	22.00	22.00	10.00	14.5	19.50	19.50	3.50	2.00	1.06	4.00	39.90	3.00	8.313	0.750 x 0.375
10 x 8 x 20	22.05	7.68	47.82	23.00	23.00	10.00	16.3	21.50	21.50	3.50	2.08	1.13	5.00	40.14	3.00	8.313	0.750 x 0.375
12 x 10 x 20	26.38	7.88	48.49	20.00	24.00	10.40	18.1	17.88	21.88	3.38	2.50	1.38	4.00	40.61	3.00	8.313	0.750 x 0.375
14 x 12 x 20	29.65	12.0	53.35	22.64	29.50	13.80	20.5	20.25	27.25	4.50	2.84	1.63	5.13	41.35	3.00	8.313	0.750 x 0.375



1. All dimensions in inches, machine tolerance +/- 0.125"
2. All motor dimensions are approximate.
3. Not valid for construction unless certified.

Dwg: SP-API-2, Rev: 0

## Standard Pump/Motor Assembly Dimensions All 6", 8", and 10" Impeller Sizes

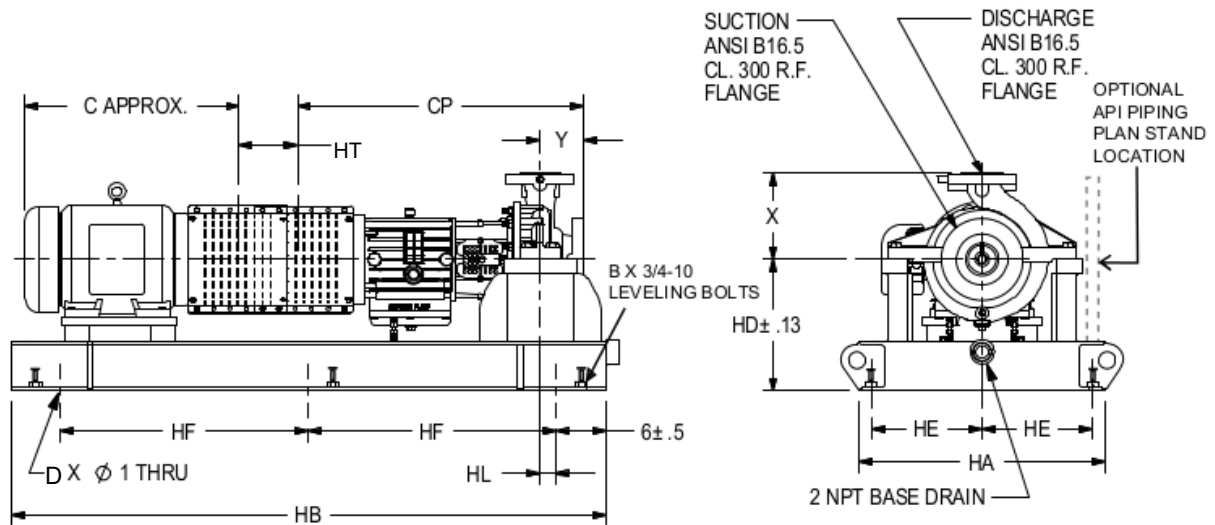

NOTE:  
1: LEVELING BOLTS ALWAYS TO OUTSIDE OF MOUNTING HOLES.

Pump Size	CODE	X	Y	CP	HL	H T	Pump Dimensions															
							182-184 T		213-215 T		254-256 T		284-286 TS		324-326 TS		364-365 TS		404-045 TS			
							Base	HD	Base	HD	Base	HD	Base	HD	Base	HD	Base	HD	Base	HD		
1 1/2 X 1 X 6	AA	6.50	4.00	27.92	4.00	5	1	17.0	1.5	17.0	-	-	-	-	-	-	-	-	-	-	-	-
2 X 1 1/2 X 6	AB	6.50	4.38	28.29	4.00	5	1	17.0	1.5	17.0	-	-	-	-	-	-	-	-	-	-	-	-
3 X 1 1/2 X 6	AC	6.50	4.00	27.92	4.00	5	1	18.0	1.5	18.0	1.5	18.0	-	-	-	-	-	-	-	-	-	-
3 X 2 X 6	AD	8.25	4.00	27.92	4.00	5	1	18.0	1.5	18.0	1.5	18.0	1.5	18.0	-	-	-	-	-	-	-	-
4 X 3 X 6	AE	11.00	5.13	29.28	4.00	5	1	19.0	1.5	19.0	1.5	19.0	1.5	19.0	1.5	19.0	-	-	-	-	-	-
1 1/2 X 1 X 8	BA	8.00	4.00	28.14	4.00	5	1	18.0	1.5	18.0	1.5	18.0	-	-	-	-	-	-	-	-	-	-
2 X 1 1/2 X 8	BB	8.00	4.38	28.54	4.00	5	1	18.0	1.5	18.0	1.5	18.0	1.5	18.0	-	-	-	-	-	-	-	-
3 X 1 1/2 X 8	BC	8.50	4.00	28.19	4.00	5	1	19.0	1.5	19.0	1.5	19.0	1.5	19.0	-	-	-	-	-	-	-	-
3 X 2 X 8	BD	9.50	4.00	28.23	4.00	5	1	19.0	1.5	19.0	1.5	19.0	1.5	19.0	1.5	19.0	-	-	-	-	-	-
4 X 3 X 8	BE	11.00	5.25	29.56	2.00	5	-	1.5	20.0	1.5	20.0	1.5	20.0	1.5	20.0	3	20.0	-	-	-	-	-
6 X 4 X 8	BF	11.25	5.50	30.17	2.00	5	-	-	-	1.5	20.0	1.5	20.0	1.5	20.0	3	20.0	5.5	20.0	-	-	-
2 X 1 1/2 X 10	CA	9.06	4.12	33.73	2.00	7	1.5	19.0	1.5	19.0	1.5	19.0	1.5	19.0	2	19.0	-	-	-	-	-	-
3 X 1 1/2 X 10	CB	8.88	5.00	34.51	2.00	7	1.5	19.0	1.5	19.0	1.5	19.0	1.5	19.0	2	19.0	-	-	-	-	-	-
3 X 2 X 10	CC	9.50	5.13	34.57	2.00	7	1.5	19.0	1.5	19.0	1.5	19.0	1.5	19.0	2	19.0	3.5	19.0	-	-	-	-
4 X 3 X 10	CD	10.50	5.25	34.85	2.00	7	-	1.5	20.0	1.5	20.0	1.5	20.0	2	20.0	3.5	20.0	5.5	20.0	-	-	-
6 X 4 X 10	CE	11.50	5.88	35.61	3.50	7	-	-	-	3	21.0	3.5	21.0	3.5	21.0	3.5	21.0	5.5	21.0	5.5	21.0	-
6 X 6 X 10	CF	15.13	6.88	36.80	3.50	7	-	-	-	5	22.0	5.5	22.0	5.5	22.0	5.5	22.0	-	-	-	-	-
8 X 6 X 10	CG	15.00	6.63	36.90	4.00	7	-	-	-	-	-	5.5	23.0	5.5	23.0	5.5	23.0	-	-	-	-	-

Pump Size	Pump Dimensions	
	444-445 TS	
	Base	HD
4 X 3 X 10	6	22.0
6 X 4 X 10	6	22.0

Baseplate Number	Baseplate Dimensions				
	HA	HB	HE	HF	D
1	30	60.5	13.5	24.25	6
1.5	30	72.5	13.5	30.25	6
2	30	84.5	13.5	24.16	8
3	36	72.5	16.5	30.25	6
3.5	36	84.5	16.5	24.16	8
5	42	72.5	19.5	30.25	6
5.5	42	84.5	19.5	24.16	8
6	42	96.5	19.5	28.17	8

NEMA Motor Dimensions (Approximate)					
NEMA Frame	C	NEMA Frame	C	NEMA Frame	C
182T	15	284TS	25	404TS	37
184T	16	286TS	27	405TS	37
213T	18	324TS	28	444TS	42
215T	20	326TS	29	445TS	42
254T	23	364TS	31		
256T	25	365TS	32		

	<ol style="list-style-type: none"> <li>1. All dimensions in inches, machine tolerance +/- 0.125"</li> <li>2. All motor dimensions are approximate.</li> <li>3. Not valid for construction unless certified.</li> </ol>	
--	--	--

### Standard Pump / Motor Assembly Dimensions All 13", 16", and 20" Impeller Sizes

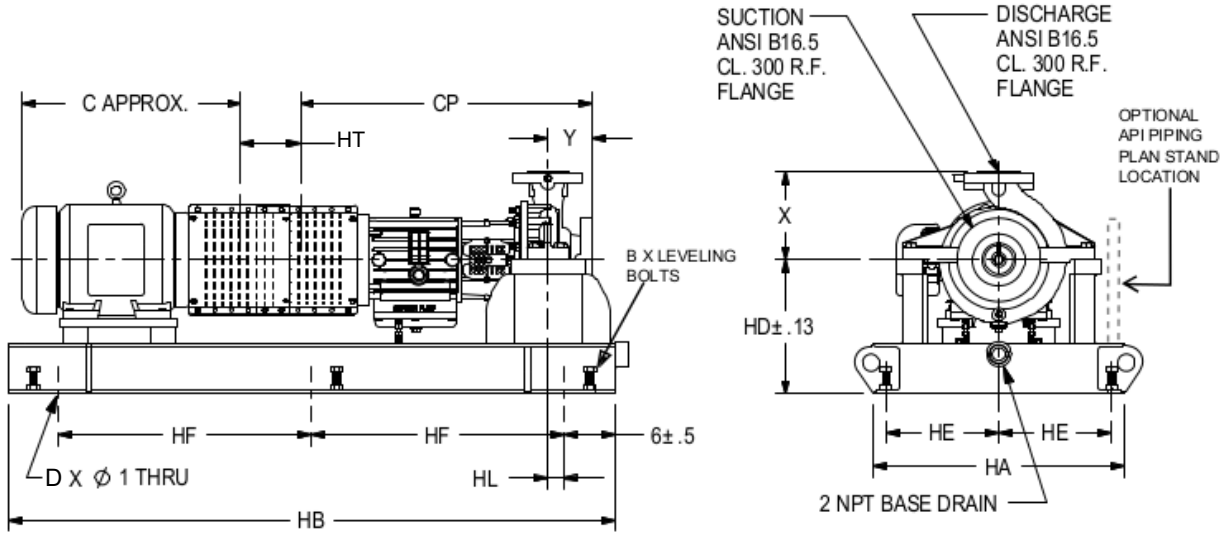

**NOTES:**

- 1: LEVELING BOLTS ALWAYS TO OUTSIDE OF MOUNTING HOLES.
- 2: CENTER BOLTS GOES TO THE RIGHT OF THE MOUNTING HOLES W/ QTY B = 6, 8, OR 10 (6 SHOWN).

Pump Size	CODE	X	Y	CP	HL	H T	Pump Dimensions											
							254-256 T		284-286 TS		324-326 TS		364-365 TS		404-405 TS		444-445 TS	
							Base	HD	Base	HD	Base	HD	Base	HD	Base	HD	Base	HD
2 X 1 1/2 X 13	DA	10.00	5.00	34.66	2	7	1.5	19	1.5	19	2	19	3.5	19	5.5	19	-	-
3 X 2 X 13	DB	11.00	5.10	34.80	2	7	3	19	3	19	3.5	19	3.5	19	5.5	19	6	21
4 X 3 X 13	DC	13.63	5.50	35.27	2	7	3	21	3	21	3.5	21	3.5	21	5.5	21	6	21
6 X 4 X 13	DD	14.00	6.00	35.97	4	7	-	-	5.5	22	5.5	22	5.5	22	6	22	6	22
6 X 6 X 13	DE	16.13	7.52	37.53	4	7	-	-	-	-	5.5	19	5.5	19	5.5	19	-	-
8 X 6 X 13	DF	16.25	6.75	37.16	4	7	-	-	-	-	5.5	24	5.5	24	6	24	6	24
10 X 8 X 13	DG	18.50	8.50	39.07	6	7	-	-	-	-	-	-	5.5	25	6	25	6	25
12 X 10 X 13	DH	22.50	10.5	41.60	10	7	-	-	-	-	-	-	9.5	26	9.5	26	10	26
6 X 4 X 16	ED	16.50	7.00	46.17	6	7	-	-	-	-	-	-	6	21	6	21	6.5	23
8 X 6 X 16	EA	17.75	7.00	46.25	6	7	-	-	-	-	-	-	6	21	6	21	6.5	23
10 X 8 X 16	EB	20.25	7.50	46.89	6	7	-	-	-	-	-	-	-	7.5	24	8	24	
12 X 10 X 16	EE	23.63	9.38	49.71	6	7	-	-	-	-	-	-	-	9.5	27	10	27	
14 X 12 X 16	EC	26.00	12.0	52.18	10	7	-	-	-	-	-	-	-	-	-	-	12	29
8 X 6 X 20	FA	19.75	7.25	47.15	6	7	-	-	-	-	-	-	-	9.5	25	10	25	
10 X 8 X 20	FB	22.05	7.68	47.82	6	7	-	-	-	-	-	-	-	9.5	27	10	27	
12 X 10 X 20	FC	26.38	7.88	48.49	6	7	-	-	-	-	-	-	-	9.5	29	10	29	
14 X 12 X 20	FD	29.65	12.0	53.35	10	7	-	-	-	-	-	-	-	-	-	-	-	-

Baseplate Number	Baseplate Dimensions				
	HA	HB	HE	HF	D
1.5	30	72.5	13.5	30.25	6
2	30	84.5	13.5	24.16	8
3	36	72.5	16.5	30.25	6
3.5	36	84.5	16.5	24.16	8
5.5	42	84.5	19.5	24.16	8
6	42	96.5	19.5	28.16	8
6.5	42	108.5	19.5	24.12	10
7.5	49	96.5	23	28.16	8
8	49	108.5	23	24.12	10
9.5	55	96.5	26	28.16	8
10	55	108.5	26	24.12	10
12	61	108.5	29	24.12	10

NEMA Motor Dimensions (Approximate)					
NEMA Frame	C	NEMA Frame	C	NEMA Frame	C
254T	23	326TS	29	444TS	42
256T	25	364TS	31	445TS	42
284 TS	25	365TS	32		
286 TS	27	404TS	37		
324 TS	28	405TS	37		

	1.	All dimensions in inches, machine tolerance +/- 0.125"	<b>Dwg: SP-API-4, Rev: 1</b>
	2.	All motor dimensions are approximate.	
	3.	Not valid for construction unless certified.	





**CARVERPUMP™**  
**Built for purpose**

2415 Park Avenue, Muscatine, IA 52761  
Phone: 563.263.3410 [www.carverpump.com](http://www.carverpump.com)

**API Maxum OH2 TECH PAGES**  
**401-17.11.EN**