



I-280

280 – 16.10.EN

ATEX

Inch Units

For Units Built After December 2015

RS – Multi-Stage, Centrifugal Pump

INSTALLATION, OPERATION AND MAINTENANCE INSTRUCTIONS

Part Number: _____

Serial Numbers: _____

 These operating instructions contain fundamental information and precautionary notes. Please read the manual thoroughly prior to installation of unit, electrical connection and commissioning. It is imperative to comply with all other operating instructions referring to components of individual units.

 This manual shall always be kept close to the unit's location of operation or directly on the pump set.



MANUFACTURER: CARVER PUMP COMPANY
2415 PARK AVE.
MUSCATINE, IOWA, USA 52761

www.carverpump.com
Phone: 1-563-263-3410
Email: sales@carverpump.com

PRODUCT DESCRIPTION: RS – Multi-Stage, Centrifugal Pump

PART NUMBER:

SERIAL NUMBER:

DATE MANUFACTURED:

APPLICABLE EUROPEAN DIRECTIVES:

Machinery: The designated product complies with the following basic requirements of Directive 2006/42/EC:
Appendix I, section 1.1.2, 1.1.3., 1.1.5., 1.3.1., 1.3.2., 1.3.3., 1.3.4., 1.3.7., 1.3.8., 1.4.1., 1.4.2.1.,
1.5.1., 1.5.8., 1.5.9., 1.5.13., 1.6.1., 1.6.4., 1.6.5., 1.7.

ATEX: 94/9/EC



APPLICABLE INTERNATIONAL STANDARDS:

Machinery: EN ISO 12100:2010 EN ISO 13732-1:2008
EN 626-1:2008 EN ISO 13857:2008

ATEX: EN 1127-1, EN 13463-1, EN 13463-5

NOTIFIED BODY

Det Norske Veritas, ATEX NB 0575 retains a copy of the Technical File

ATEX product marking:   II 2 G c T2

The product described in this Declaration of Conformity complies with the Applicable European Directives and relevant sections of the Applicable International Standards. The signature on this document authorizes the distinctive European mark to be applied to the equipment described. A Technical Construction File is available for inspection by designated bodies

Authorized Signature:

Date:

Mike Moyer
Engineering Manager



Important safety information is contained in the installation, operation and service manuals; read and understand this information prior to installing or using this equipment.

This Document applies only to the equipment described above and is invalid if not reproduced in its entirety.

SERVICE RECORD PAGE

Service No. _____ Model _____ Size and Type _____

Customer Order No. _____ Date Installed _____

Installation Date	Location	Application

PUMP RATING

Capacity _____ Total Head _____

Suction Pressure _____ Speed (RPM) _____

Liquid pumped _____ Temperature _____

Specific Gravity _____ Viscosity _____

Service _____

PUMP MATERIALS

Casing _____ Impeller _____ Shaft _____

Gaskets _____ Bearing Frame _____

Mechanical Seal/Packing _____

MOTOR DATA

Motor _____ Make _____ Serial No. _____

Type _____ Frame _____ AC or DC _____

HP _____ RPM _____ Volts _____

Phase _____ Cycles _____

NOTES ON INSPECTION AND REPAIRS

INSPECTION DATE	REPAIR TIME	REPAIRS	COST	REMARKS

INSTALLATION, OPERATION AND MAINTENANCE INSTRUCTIONS

TABLE OF CONTENTS

SECTION/PARAGRAPH	PAGE	SECTION/PARAGRAPH	PAGE
I. GENERAL DESCRIPTION.....	1	D. Leveling of Unit	18
A. General Information	1	E. Grouting	18
B. ATEX Directive 94/9/EC.....	1	F. Coupling Alignment.....	20
C. Disclaimer	1	G. Pre-Installation Procedures	21
D. Personnel Qualification and Training.....	1	H. Piping	21
E. Pump Identification.....	1	I. Auxiliary Piping Connection	
F. Parts Inventory Guide	2	and Gauges	21
G. Parts Ordering.....	2	J. Motor	21
II. SAFETY.....	2	K. Direction of Rotation	21
A. Safety Precautions	2	VIII. OPERATION	22
B. Summary of Safety Marking.....	2	A. Pre-Start Cautions	22
C. Products Used in Potentially Explosive		B. Priming.....	22
Atmospheres	2	C. Starting the Pump	23
D. Scope of Compliance	2	D. Turbine Applications	23
E. Safety Awareness	3	E. Minimum/Maximum Flow Calculations	23
F. Safety Instructions for the Operator/User ..	3	F. Operating Checks	23
G. Safety Instructions for Maintenance		G. Stopping the Pump	23
Inspection and Installation Work	3	H. Indefinite Shutdown	24
H. Non-Compliance with Safety Instructions ..	3	IX. TROUBLESHOOTING OPERATING	
I. Unauthorized Modification and		PROBLEMS.....	24
Manufacture of Spare Parts	3	X. MAINTENANCE	26
J. Unauthorized Modes of Operation	4	A. Lubrication of Pump Bearings.....	26
K. Explosion Protection	4	B. Lubrication of Motor Bearings.....	27
III. EQUIPMENT DESCRIPTION.....	7	C. Torque Values.....	27
IV. EFFECTS OF FLUIDS	8	XI. SERVICE AND REPAIR.....	28
A. Net Positive Suction Head (NPSH).....	8	A. Preparations for Disassembly of Pump	28
B. Changing Pump Speed	8	B. Disassembly of Pump with	
C. Effects of Viscosity	8	Standard Sleeve Bearing	29
D. Effects of Specific Gravity	8	C. Disassembly of Pump with	
V. TECHNICAL DATA.....	8	Optional Mechanical Seals	31
VI. INSPECTION AND STORAGE	16	D. Parts Inspection	33
A. Inspection.....	16	E. Reassembly of Pump with	
B. Packing for Return	16	Standard Sleeve Bearing	35
C. Storage of Pump	16	F. Reassembly of Pump with	
VII. INSTALLATION	17	Optional Mechanical Seals	39
A. Location.....	17	G. Replacement of Wear Ring.....	42
B. Handling.....	17	H. Motor	44
C. Foundation	17	I. Check Valve	44
		XII. PARTS LISTS AND DRAWINGS	44

TABLE OF CONTENTS - Continued

LIST OF TABLES			LIST OF ILLUSTRATIONS		
NUMBER	TITLE	PAGE	NUMBER	TITLE	PAGE
1.	Fluid Temperature Limits	5	1.	Seal Chamber Dimensions	11
2.	Maximum Allowable Pressures.....	6	2.	Standard Seal Flush Plans	13
3.	Axial Impeller Alignment Control Dimensions.....	9	3.	Bearing Frame Water Cooling	14
4.	Shaft Dimensions.....	12	4.	Sling Position for Moving Pump.....	17
5.	Sleeve Bearing Dimensions.....	12	5.	Sling Position for Moving Pumping Unit	17
6.	Standard Design Pump Mechanical Seal Settings	12	6.	Sling Position for Moving Pumping Unit with Lifting Lugs	17
7.	Optional Design Pump Mechanical Seal Settings	13	7.	Grouting and Foundation Bolting	19
8.	Key Mechanical Data	13	8.	Unit Leveling	19
9.	Permissible Nozzle Loads	15	9.	Coupling Alignment.....	20
10.	Minimum Flow Rates RS-6 and RS-9.....	15	10.	Constant Level Oiler	27
11.	Pumping Unit Troubleshooting	24	11.	Bushing Not Torqued Interference	38
12.	Oil Recommendations.....	27	12.	Tie Rods Not Torqued Interference	42
13.	Bearing Cooling Flow Rates (30 PSIG Max.)	27	13.	Sectional Assembly – Standard Sleeve Bearing	49
14.	Recommended Torque Values (ft-lbs).....	27	14.	Sectional Assembly – Optional Mechanical Seals.....	51
15.	Recommended Equipment	27	15.	Cooling Options	52
16.	Maximum Recommended Wear Ring Clearance (Inches).....	34			
17.	New Wear Ring Diametrical Clearance Limits (Inches)	43			
18.	Recommended Spare Parts List.....	45			

I. GENERAL DESCRIPTION AND SAFETY PRECAUTIONS.

A. GENERAL INFORMATION. Carver Pump Company products are carefully engineered and manufactured and, if properly installed, maintained, and operated, should provide maintenance-free operation and a long service life.



These instructions must always be kept close to the product's operating location or directly with the product.

This manual is designed to provide sufficient material to properly maintain the total pumping unit. The information presented should improve your knowledge and understanding of the RS Multi-Stage Centrifugal Pump, thus upgrading the reliability, service life, and quality of pump maintenance.

These operating instructions are intended to facilitate familiarization with the product and its permitted use to help satisfy ATEX safety requirements. These operating instructions do not take into account local regulations; the operator must ensure that such regulations are strictly observed by all, including the personnel called in for installation. Compliance with such laws relating to the proper installation and safe operation of the pumping equipment is the responsibility of the equipment owner and all necessary steps should be taken by the owner to assure compliance with such laws before operating the equipment. These instructions are intended to facilitate familiarization with the product and its permitted use to help satisfy safety requirements. Always coordinate repair activity with operations personnel and follow all plant safety requirements and applicable safety and health laws/regulations.

Refer to Figures 13, 14, and 15 to locate the pump parts by item number. Variations do exist between configurations, not all parts described in the text may be on your configuration.



These instructions should be read prior to installing, operating, using and maintaining the equipment in any region worldwide and in conjunction with the main user instructions provided. The equipment must not be put into service until all the conditions relating to safety instructions have been met.

B. ATEX DIRECTIVE 94/9/EC. It is a legal requirement that machinery and equipment put into service within certain regions of the world shall conform to the applicable CE Marking Directives for Equipment for Potentially Explosive Atmospheres (ATEX).

Where applicable the Directive covers important safety aspects relating to the equipment, its use and the satisfactory provision of technical documents. Where applicable this document incorporates information relevant to these Directives. To establish if the product itself is CE marked for a Potentially Explosive Atmosphere check the nameplate and the Certification provided.

C. DISCLAIMER. Information in these User Instructions is believed to be reliable. In spite of all the efforts of Carver Pump Company to provide sound and all necessary information the content of this manual may appear insufficient and is not guaranteed by Carver Pump Company as to its completeness or accuracy.

D. PERSONNEL QUALIFICATION AND TRAINING. All personnel involved in the operation, installation, inspection and maintenance of the unit must be qualified to carry out the work involved. If the personnel in question do not already possess the necessary knowledge and skill, appropriate training and instruction must be provided. If required, the operator may commission the manufacturer/supplier to provide applicable training.

Follow instructions in this manual carefully. Factory warranty applies only when pump operates under conditions as specified on order acknowledgment, and if pump is properly installed and maintained as recommended herein. A copy of this manual should be available to operating personnel. Additional copies of this manual are available upon request from Carver Pump Company and your local distributor. For comments and/or questions about information provided, please contact Carver Pump Company or your local distributor.

E. PUMP IDENTIFICATION. The type of pump, pump size, operating data, and serial number are all stamped on the nameplate attached to the pump. Pump specifications should be recorded upon receipt of the pumping unit. Record all necessary information on the pump service record page and inspection and repair record provided at the front of this manual. This information must be included in all correspondence regarding the unit. This will ensure that the correct pump and/or parts are ordered in a timely manner.

F. PARTS INVENTORY GUIDE. To avoid unnecessary delays for maintenance, spare parts should be readily available, purchase before and keep in stock, for normal service. Most conditions will be covered if this manual is followed. For every one to three pumps, stock one spare set consisting of items listed in Table 19, Recommended Spare Parts. Part numbers correspond to Figures 11, 12 and 13.

G. PARTS ORDERING. When ordering replacement parts, please specify:

- Serial number of pump (located on nameplate)
- Part name (located on parts list)
- Quantity of parts needed

Carver Pump Company may ship an interchangeable part that is not identical in appearance or symbol. This is done only if the part has been improved. Examine parts carefully upon delivery before questioning factory or company representative. Never return parts to the factory without authorization from Carver Pump Company.

If an impeller is ordered, specify diameter across blade tips. Be sure diameter was NOT trimmed further than diameter shown on Carver Pump Company records.

If a driver or driver parts are ordered, specify name of manufacturer and all other data found on the driver nameplate.

II. SAFETY.

A. SAFETY PRECAUTIONS. The manual is designed to provide adequate instructions for the safe and efficient installation, operation, or maintenance of the pump. Failure or neglect to properly install, operate, or maintain the pump may result in personal injury, property damage, or unnecessary damage to the pump. This manual must be read and understood both by the installing personnel and the responsible trained personnel/operators prior to installation and operation, and it must always be kept close to the location of the pumping unit for easy access.

B. SUMMARY OF SAFETY MARKING. The safety instructions contained in this manual follow specific ATEX safety marking where non-observance of the instruction will cause a hazard is specially marked with the symbol:



This symbol indicates explosive atmosphere marking according to ATEX. It is

used in safety instructions where non-compliance in the hazardous area would cause the risk of an explosion.



General hazard sign to ISO 7000 - 0434.

The word "Caution" is used to introduce safety instructions whose non-observance may lead to damage to the machine and its functions.

Instructions attached directly to the machine, e.g.

- Arrow indicating the direction of rotation
- Markings for fluid connections must always be complied with and be kept in a perfectly legible condition at all times.

Observe all notes, caution or danger tags attached to the equipment or included in this manual.

C. PRODUCTS USED IN POTENTIALLY EXPLOSIVE ATMOSPHERES



Measures are required to:

- Avoid excess temperature
- Prevent buildup of explosive mixtures
- Prevent the generation of sparks
- Prevent leakages
- Maintain the pump to avoid hazard

The following instructions for pumps and pump units when installed in potentially explosive atmospheres must be followed to help ensure explosion protection. Both electrical and non-electrical equipment must meet the requirements of European Directive 94/9/EC.

D. SCOPE OF COMPLIANCE.



Use equipment only in the zone for which it is appropriate. Always check that the driver, drive coupling assembly, seal and pump equipment are suitably rated and/or certified for the classification of the specific atmosphere in which they are to be installed.

Where Carver Pump has supplied only the bare shaft pump, the Ex rating applies only to the pump. The party responsible for assembling the pump set shall select the

coupling, driver, seal and any additional equipment, with the necessary CE Certificate/Declaration of Conformity establishing it is suitable for the area in which it is to be installed.

The output from a variable frequency drive (VFD) can cause additional heating affects in the motor and so, for pump sets with a VFD, the ATEX Certification for the motor must state that it covers the situation where electrical supply is from the VFD. This is particular requirement still applies even if the VFD is in a safe area.

E. SAFETY AWARENESS. It is imperative to comply with the safety instructions contained in this manual, the relevant national and international explosion protection regulations, health and safety regulations and the operator's own internal work, operation and safety regulations.



Ex symbol relates to additional requirements which must be adhered to when the pump is operated in potentially explosive atmospheres.

F. SAFETY INSTRUCTIONS FOR THE OPERATOR /USER.

- Any hot or cold components that could pose a hazard must be equipped with a guard by the operator.
- Guards which are fitted to prevent accidental contact with moving parts (e.g. coupling) must not be removed whilst the unit is operating.
- Leakages (e.g. at the shaft seal) of hazardous fluids (e.g. explosive, toxic, hot) must be contained so as to avoid any danger to persons or the environment. Pertinent legal provisions must be adhered to.
- Electrical hazards must be eliminated. (In this respect refer to the relevant safety regulations applicable to different countries and/or the local energy supply companies.)



If the pumps/units are located in potentially explosive atmospheres, it is imperative to make sure that unauthorized modes of operation are prevented. Non-compliance may result in the specified temperature limits being exceeded.

G. SAFETY INSTRUCTIONS FOR MAINTENANCE, INSPECTION AND INSTALLATION WORK.

The operator is responsible for ensuring that all maintenance, inspection and installation work be performed by authorized, qualified personnel who are thoroughly familiar with the manual and pumping unit.



To ensure safe operation the ball bearings must be replaced at 20000 hours of service or whenever the mechanical seal is inspected or serviced.

The pumping unit must have cooled down to ambient temperature, pump pressure must have been released, and the pump must have been drained before working on any pumping unit. Work on the pumping unit must be carried out during shutdown. The shutdown procedure described in the manual for taking the unit out of service must be adhered to.

Pumps handling fluids that are hazardous to personnel must be decontaminated prior to being worked on.

Immediately following completion of the work, all safety relevant and protective devices must be reinstalled and/or reactivated. Please observe all instructions set out in the Section VIII on start up before returning the pumping unit to service.

H. NON-COMPLIANCE WITH SAFETY INSTRUCTIONS.

Non-compliance with safety instructions may result in personal injury, property damage, or unnecessary damage to the pumping unit. Non-compliance with these safety instructions will also lead to forfeiture of any and all rights to claims for damages. Non-compliance, can for example, result in:

- Failure of important pumping unit functions.
- Failure of prescribed maintenance and servicing practices.
- Hazard to personnel by electrical, mechanical, and chemical effects as well as explosion.
- Hazard to the environment due to leakage of hazardous substances.

I. UNAUTHORIZED MODIFICATION AND MANUFACTURE OF SPARE PARTS.

Modifications or alterations of the pumping unit supplied are only permitted after consultation with Carver Pump and to the extent permitted by Carver Pump. Original spare parts and accessories authorized by Carver Pump ensure safety. The use of other parts can invalidate any liability of Carver Pump for consequential damage and/or warranty.

J. UNAUTHORIZED MODES OF OPERATION. The warranty relating to operating reliability and safety of the unit supplied is only valid if the pumping unit is used in accordance with its designated use as described in the following sections. The limits stated on the nameplate must not be exceeded under any circumstances.

K. EXPLOSION PROTECTION. If the pumps/units are installed in potentially explosive atmospheres, the measures and instructions given in the following sections K.1 to K.6 must be adhered to without fail, to ensure explosion protection.

K.1 Unit Fill.

 It is assumed that the system of suction and discharge lines and thus the wetted pump internals are completely filled with the fluid to be handled at all times during pump operation, so that an explosive atmosphere is prevented.

 If the operator cannot warrant this condition, appropriate monitoring devices must be used.



In addition, it is imperative to make sure that the seal chambers, auxiliary systems of the shaft seal and the heating and cooling systems are properly filled.

K.2 Marking.

 The marking on the pump only refers to the pump, i.e. the coupling and driver must be regarded separately. The coupling must have an EC manufacturer's declaration. The driver must be regarded separately.

An example of ATEX equipment marking is shown below. The actual classification of the pump will be engraved on the nameplate.

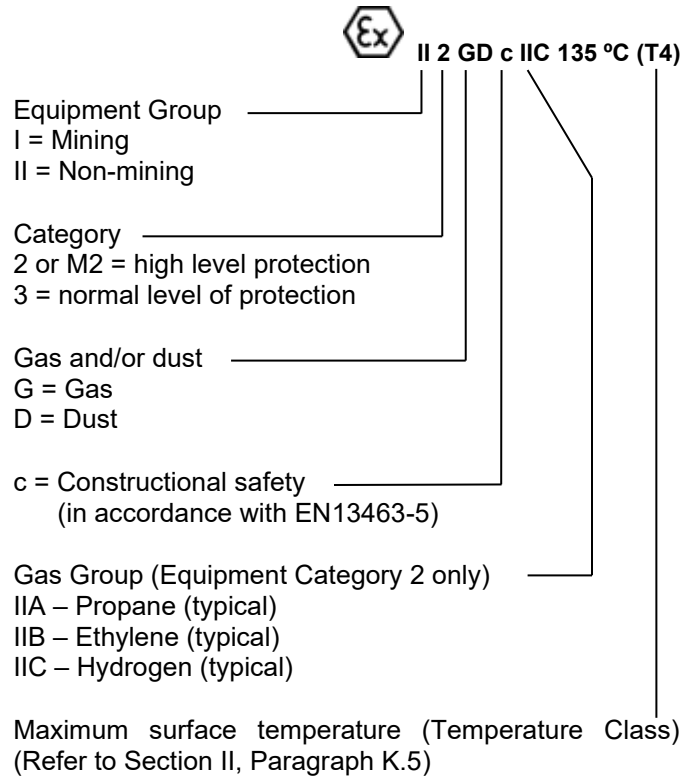

K.3 Checking the Direction of Rotation.

 If the explosion hazard also exists during the installation phase, the direction of rotation must never be checked by starting up the unfilled pump unit, even for a short period, to prevent temperature increases resulting from contact between rotating and stationary components.

K.4 Pump Operating Mode.

Make sure that the pump is always started up with the suction-side shut-off valve fully open and the discharge-side shut-off valve slightly open. However, the pump can also be started up against a closed swing check valve. The discharge-side shut-off valve shall be adjusted to comply with the duty point immediately following the run-up process.



Pump operation with the shut-off valves in the suction and/or discharge pipes closed is not permitted.



CAUTION

In this condition, there is a risk of the pump casing taking on high surface temperatures after a very short time, due to a rapid temperature rise in the pumped fluid inside the pump. Additionally, the resulting rapid pressure build-up inside the pump may cause excessive stresses on the pump materials or even bursting.

The minimum flows calculated in Section VIII, Paragraph E, refer to water and water-like liquids. Longer operating periods with these liquids and at the flow rates indicated will not cause an additional increase in the temperatures on the pump surface. However, if the physical properties of the fluids handled are different from water, it is essential to check if an additional heat build-up may occur and if the minimum flow rate must therefore be increased.

To check, proceed as described in Section VIII, Paragraph E.

In addition, the instructions given in Section VIII of this operating manual must be observed.



Mechanical seals may exceed the specified temperature limits if run dry. Dry running may not only result from an inadequately filled seal chamber, but also from excessive gas content in the fluid handled.

Pump operation outside its specified operating range may also result in dry running.

K.5 Temperature Limits.



In normal pump operation, the highest temperatures are to be expected on the surface of the pump casing, at the shaft seal and in the ball bearing areas. The surface temperature at the pump casing corresponds to the temperature of the fluid handled.

If the pump is heated, it must be ensured that the temperature classes stipulated for the plant are observed.

In the ball bearing bracket area, the unit surfaces must be freely exposed to the atmosphere and the fan inlet flow must be unimpeded.



In any case, responsibility for compliance with the specified fluid temperature (operating temperature) lies with the plant operator. The maximum permissible fluid temperature depends on the temperature class to be complied with.

Table 1 below lists the temperature classes to EN 13463-1 and the resulting theoretical temperature limits of the fluid handled. In stipulating these temperatures, any temperature rise in the shaft seal area has already been taken into account.

Table 1. Fluid Temperature Limits

Temperature class to EN 13463-1:	Temperature limit of fluid handled
T5	185 °F (85 °C)
T4	284 °F (120 °C)
T3	365 °F (185 °C)
T2	536 °F (280 °C)
T1	662 °F (350 °C)



CAUTION

The permissible operating temperature of the pump in question is indicated on the data sheet. If the pump is to be operated at a higher temperature, the data sheet is missing or if the pump is part of a pool of pumps, the maximum permissible operating temperature must be enquired from the pump manufacturer.

Based on an ambient temperature of 104° Fahrenheit (F) [40° Celsius (C)] and proper maintenance and operation, compliance with temperature class T4 is warranted in the area of the rolling element ball bearings. A special design is required for compliance with temperature class T6 in the ball bearing area. In such cases, and if ambient temperature exceeds 104°F (40°C), contact the manufacturer.



Pump liquids over 225°F (107°C); pumps must be equipped with auxiliary cooling.

Pumps of high temperature construction are provided with cooled ball bearings for a unit operating in temperature range between 225° F and 300° F (107° C and 149° C). Cooling water flows through cavities of the bearing frame and keeps temperature of the ball bearings within acceptable limits. Refer to Table 13 for cooling flow rates of water temperature of 60° F (15.6°C) for ball bearings.

K.6 Maintenance.



Only a pumping unit which is properly serviced and maintained in perfect technical condition will give safe and reliable operation.

This also applies to the reliable function of the thrust or radial ball bearings whose actual lifetime largely depends on the operating mode and operating conditions. Regular checks of the lubricant and the running noises will prevent the risk of excessive temperatures as a result of the thrust or radial ball bearings running hot or defective bearing isolators.

The correct function of the bearing isolators must be checked regularly. Any auxiliary systems installed must be monitored, as necessary, to make sure that they function correctly.

K.7 General Safety Instructions.

- Various federal, state, and local laws affect installation, use, and operation of pumping equipment. Compliance with such laws relating to proper installation and safe operation of pumping equipment is the responsibility of the equipment owner.
- Prior to working on pump or driver, ensure all switches and circuit breakers have been locked in the open (off) position and tagged, "Out of Service."
- All circuits NOT known to be dead must be considered live at all times.
- DO NOT wear loose or torn clothing around rotating machines.
- While working near electricity, DO NOT use metal rules, flashlights, metallic pencils, or any other objects having exposed conducting material.

- Make sure you are NOT grounded while adjusting electrical equipment or using measuring equipment.
- In general, use only one hand when servicing live electrical equipment.
- Make sure to de-energize all electrical equipment before connecting or disconnecting meters or test leads.
- For connecting a meter to terminals for measurement, use a range higher than the expected voltage.
- Check to make sure that the frame of the driver and starter panel are securely grounded before operating pumping unit or performing any tests or measurements.
- If a test meter must be held or adjusted while voltage is applied, ground case of meter before starting measurement. DO NOT touch live equipment while holding the meter. Some moving vane-type meters should not be grounded nor held during measurements.
- DO NOT use test equipment known to be damaged or in poor condition.

The following specific safety precautions apply to the pumping unit:

- Hydro suction case separately on RS-9 units.
- Isolate pump for system hydro.
- DO NOT exceed maximum rated suction pressure unless otherwise rated.
- DO NOT exceed maximum rated discharge pressure.

Table 2. Maximum Allowable Pressures

Size	Suction	Discharge
A	415 PSIG*	1,475 PSIG
B		1,475 PSIG
C		1,475 PSIG
D		1,810 PSIG
E		1,460 PSIG

*Unless otherwise rated.

III. EQUIPMENT DESCRIPTION.

RS high-pressure pumps are multi-stage, centrifugal pumps with radially split casings. The pump consists of a suction case, a discharge case, plus a number of interstage casings, all secured with tie bolts. Suction casing, interstage casings and diffusers are provided with wear rings. Diffusers are provided with bushings. Due to prolonged operation, wear rings and bushings may become worn and/or damaged. Replace all worn and/or damaged parts with new.

RS high-pressure pumps incorporate special design refinements, which help to absorb the appreciable axial thrust generated by their high head operation. Residual axial thrust is absorbed by the thrust bearings.



CAUTION



Be careful not to mix RS6 and RS9 parts since RS6 parts are not rated for the pressure of the RS9.



ATEX and CE require bearing isolators and metal splash guards to meet requirements. Other customers may use oil seals and plastic splash guards.

The bare pump consists of following major parts and options. Refer to Figures 11 and 12, for the location of parts identified by item numbers.

Item 1 – Discharge Case. The Discharge Case (1) houses the impeller (2A or 2X) and diffuser (5A or 5X). The discharge case is fastened to the suction case with tie bolts (173) and tie bolt nuts (616) with tie bolt washers (645).

Item 2A – Impeller, 1st Stage. RS pumps are equipped with enclosed impellers. The impeller (2A) is keyed to the shaft (6) by the impeller key (32A) and located by sleeves and shims. If the RS pump is only a one stage pump then only the 1st stage impeller is used. All impellers face the same direction on the shaft.

Item 2X – Impeller. RS pumps are equipped with enclosed impellers. The impeller (2X) is keyed to the shaft (6) by the impeller key (32A) and located by interstage sleeves (58) and shims. All impellers face the same direction on the shaft.

Item 5A – Diffuser. Diffusers (5A) are inserted in individual interstage casings. Diffusers are provided with diffuser bushings (63) and hold wear rings (7X).

Item 5X – Last Stage Diffuser. The last stage diffuser is located in the discharge case (1). Holds wear ring (7X) and sits on sleeve bearing (63X).

Item 6 – Shaft. The pump shaft is protected against wear by interstage sleeves, spacer sleeves, and shaft sleeves. The shaft (6) of the RS pump is designed for maximum deflection of 0.002 inch at the face of the mechanical seal (90). The shaft is also designed to provide stabilization to the rotor system when pump operates away from the best efficiency point. A coupling connects the shaft to the driver shaft. The pump coupling key (46) holds the coupling in place, causing it to rotate with the shaft.

Item 16 and 18 – Ball Bearings. A deep-groove Conrad-type, C3 internal fit radial ball bearing and a back-to-back mounted ball bearing are housed in the bearing frame (99) depending on design. The ball bearings will be designated as 7000 series. Ball bearings designated in the 7000 series will be duplex 40° angular contact ball bearings. The ball bearing is held in place by the bearing jam nuts (22). The bearings are oil lubricated by oil bath.

Item 99 – Bearing Frame. The principal function of the bearing frame (99) is to carry the loads from the liquid end of the pump to the base and to transport power from the power unit to the impeller (2A or 2X). The bearing frame has a pair of back-to-back mounted angular contact thrust ball bearings (16). This bearing frame is designed to be oil lubricated. The bearing frame is attached to the suction case (9) and discharge case (1) by tie bolts.

The use of a sight glass constant level oiler (143) maintains the oil level high enough on the higher of the two ball bearings so that the ball bearings themselves provide the motivation for the oil to be moved through the races of the ball bearings. In addition to the oil lube, the bearing frame contains the bearing isolator (169).

Item 23 – Base. A grout-able base (23) is designed to provide adequate support for the pump and motor so pump can be operated without base deflection, excessive vibration, or resonance. The pump is attached to the base with stud (634) and hex nut (614). Grouting of this type of base is required by Carver Pump Company.

Item 90 and 91 – Mechanical Seal. Mechanical seals (90 and 91) are to be used. Complete mechanical seal instructions should be obtained from the seal manufacturer. The standard seal chamber dimensions are shown in Figure 1.

Item 111 – Interstage Case. The interstage case houses the impeller (2A or 2X) and diffuser (5A). The interstage casings are all secured with tie bolts to the

suction (9) and discharge (1) casings. Interstage casings are provided with wear rings (7X). O-rings (89D) seal the individual interstage casings. A one stage pump does not have an interstage case.

IV. EFFECTS OF FLUIDS.



Solids in the fluid pumped may cause internal damage to pump casing and damage to the seal faces with resulting Hazardous conditions. Care is to be taken to ensure that the process fluid is clear of solids and debris.

A. NET POSITIVE SUCTION HEAD (NPSH). Any liquid, hot or cold, must be pushed into the impeller of the pump by some absolute pressure, such as the atmosphere or the vessel pressure from which the pump takes its action.

The head in feet of liquid necessary to maintain the required flow into the pump is called the Net Positive Suction Head (NPSH). This value is measured above the vapor pressure of the liquid at the pumping temperature.

NPSH is commonly expressed in two ways: the NPSH required by the pump, and shown on the pump curve, is the head needed to cover the losses in the pump suction and the energy required to enable the liquid to climb onboard the leading edge of the impeller vane. The NPSH available is that inherent in the system, taking into account friction losses in suction piping, valves, fittings, etc. In all cases, the NPSH available, measured above vapor pressure, must exceed the NPSH required in order to push the liquid into the pump.

B. CHANGING PUMP SPEED. Changing the speed of a centrifugal pump affects the capacity, total head, NPSH required and the brake horsepower. In general, the capacity will vary in a direct ratio with the speed, whereas the total head and NPSH required will vary as the ratio of the speed squared. The brake horsepower will vary as the ratio of the speed cubed.

C. EFFECTS OF VISCOSITY. The pump is designed to deliver rated capacity at rated head for a liquid with a particular viscosity. When pump is handling heavy viscous liquid, the viscosity of the liquid must allow it to be pumped easily. The liquid may have to be heated prior to starting the pump. When contemplating operation at some viscosity other than that for which the pump was originally designed, check with Carver Pump Company.

D. EFFECTS OF SPECIFIC GRAVITY. The capacity and total head in feet of liquid developed by a centrifugal pump are fixed for every point on the curve and are always the same for the same speed. Neither capacity nor total head will be affected by a change in the specific gravity of the liquid pumped. However, since the discharge pressure in Pounds per Square Inch (PSI) and the brake horsepower required driving the pump are functions of the specific gravity of the liquid, both will be affected in direct proportion by any change in specific gravity. Therefore, an increase in specific gravity will raise the discharge pressure and is dangerous as it might overload the pump's driver or exceed the pump casing allowable pressure.

V. TECHNICAL DATA.

Specifications and operating limits should be recorded on a Service Record Page; an example is located in the front matter of this manual. Record the necessary information upon receipt of the pumping unit.

Noise Levels. Noise levels may exceed 85dBa at 1 meter during operation. Ear protection must be worn whenever working in high noise locations.

Axial Impeller Alignment Control Dimensions. Axial impeller alignment control dimensions are located in Table 3 and are arranged by pump size.

Seal Chamber Dimensions. Standard seal chamber dimensions are located in Figure 1 and are arranged by pump size.

Basic Design Features. Basic design features of the pump are located in Tables 3, 4, 5, 6, 7, 10, and Figures 2 and 3 and are arranged by pump model.

Key Mechanical Data. Key mechanical data for the pump is located in Table 8 and is arranged by pump model.

Permissible Nozzle Loads. The forces and moments in Table 9 are to be understood as the limit for a single acting force or moment along the particular coordinate axes or any resultant of two or more forces and moment.

Table 3. Axial Impeller Alignment Control Dimensions

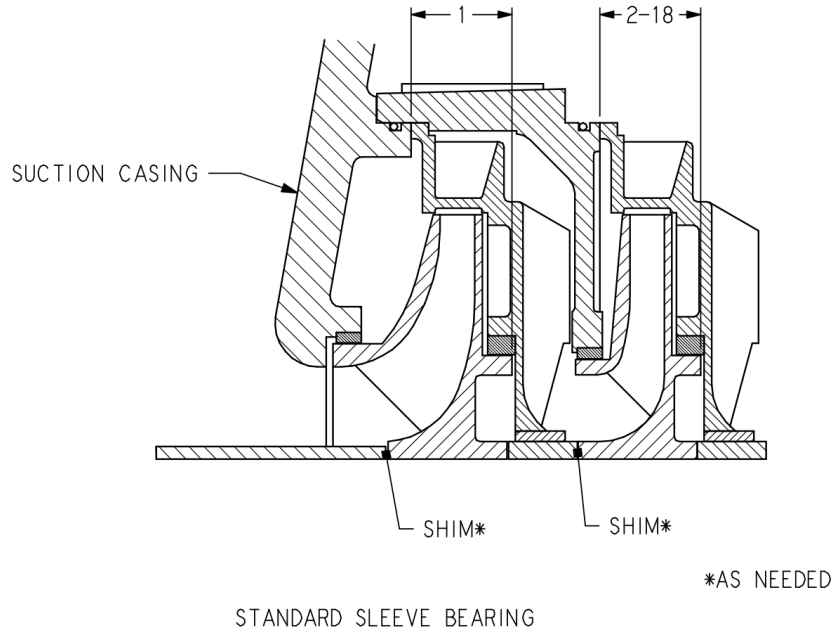

Stages	Pump Size A (Inches)	Pump Size B (Inches)	Pump Size C (Inches)	Pump Size D (Inches)	Pump Size E (Inches)
1	1.147	1.150	1.267	1.580	2.063
2	1.144	1.143	1.263	1.635	2.019
3	1.141	1.140	1.260	1.632	2.016
4	1.138	1.137	1.257	1.629	2.013
5	1.135	1.134	1.254	1.626	2.010
6	1.132	1.131	1.251	1.623	2.007
7	1.129	1.128	1.248	1.620	2.004
8	1.126	1.125	1.245	1.617	2.001
9	1.123	1.122	1.242	1.614	N/A
10	1.12	1.119	1.239	1.611	N/A
11	1.117	1.116	1.236	1.608	N/A
12	1.114	1.113	1.233	1.605	N/A
13	1.111	1.110	N/A	N/A	N/A
14	1.108	1.107	N/A	N/A	N/A
15	1.105	1.104	N/A	N/A	N/A
16	1.102	1.101	N/A	N/A	N/A
17	1.099	1.098	N/A	N/A	N/A
18	1.096	1.095	N/A	N/A	N/A

*Additional stages will require compensation for interstage compression, on average .003 inch per stage. Use .010 inch shim as needed. Refer to Section XI, Paragraphs E.

Table 3. Axial Impeller Alignment Control Dimensions - Continued

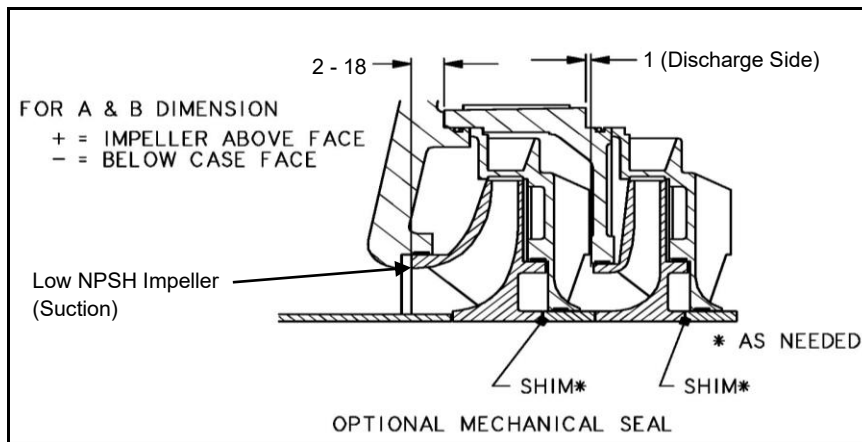

Stages	Pump Size A (Inches)	Pump Size B (Inches)	Pump Size C (Inches)	Pump Size D (Inches)	Pump Size E (Inches)
1	-.110	-.110	-.125	.137	.185
2	-.113	-.113	-.128	.134	.182
3	-.116	-.116	-.131	.131	.179
4	-.119	-.119	-.134	.128	.176
5	-.122	-.122	-.137	.125	.173
6	-.125	-.125	-.140	.122	.170
7	-.128	-.128	-.143	.119	.167
8	-.131	-.131	-.146	.116	.164
9	-.134	-.134	-.149	.113	N/A
10	-.137	-.137	-.152	.110	N/A
11	-.140	-.140	-.155	.107	N/A
12	-.143	-.143	-.158	.104	N/A
13	-.146	-.146	N/A	N/A	N/A
14	-.149	-.149	N/A	N/A	N/A
15	-.152	-.152	N/A	N/A	N/A
16	-.155	-.155	N/A	N/A	N/A
17	-.158	-.158	N/A	N/A	N/A
18	-.161	-.161	N/A	N/A	N/A
Low NPSH Impeller	See note below	See note below	See note below	See note below	See note below

*Additional stages will require compensation for interstage compression, on average .003 inch per stage. Use .010 inch shim as needed. Refer to Section XI, Paragraphs F.

RSA No NPSH Impeller

RSB $.210 - [\text{\#of stages} \times (.003) - \text{Gaps}] = \text{NPSH Impeller Setting}$

RSC $.538 - [\text{\#of stages} \times (.003) - \text{Gaps}] = \text{NPSH Impeller Setting}$

RSD $.792 - [\text{\#of stages} \times (.003) - \text{Gaps}] = \text{NPSH Impeller Setting}$

RSE $.249 - [\text{\#of stages} \times (.003) - \text{Gaps}] = \text{NPSH Impeller Setting}$

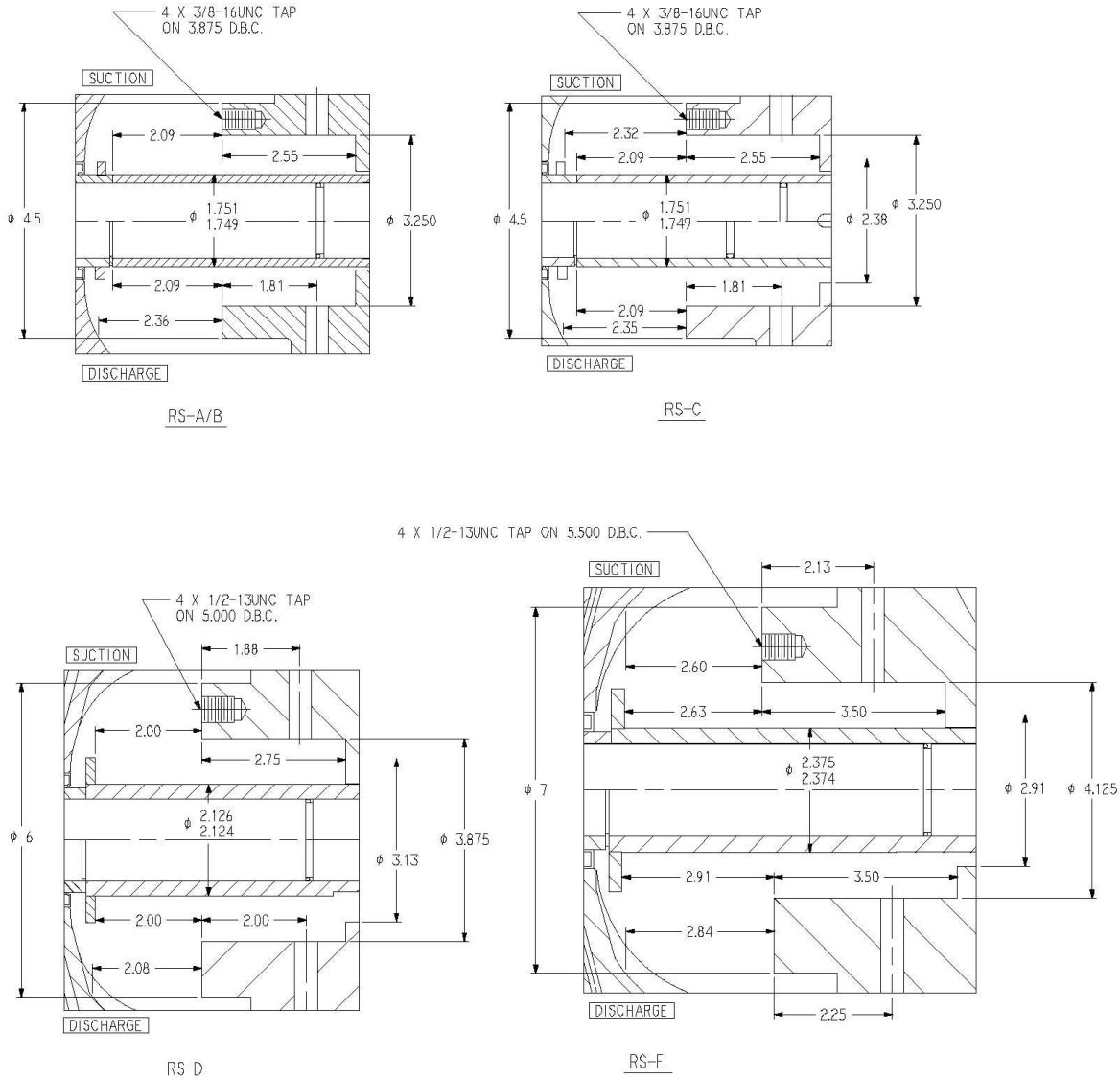

Figure 1. Seal Chamber Dimensions

Table 4. Shaft Dimensions

Pump Model	At Impeller (Inches)	At Coupling (Inches)
A	1.437	1.250
B	1.437	1.250
C	1.437	1.250
D	1.574	1.500
E	1.771	1.625

Table 5. Sleeve Bearing Dimensions

Pump Model	Sleeve Bearing New (Inches)	Sleeve Bearing Replacement Limits (Inches)	Sleeve (Ø = Diameter Measured)	
			New (Inches)	Replace (Inches)
A	1.758/1.760	Ø > 1.762	1.751/1.749	Ø < 1.746
B	1.758/1.760	Ø > 1.762	1.751/1.749	Ø < 1.746
C	1.758/1.760	Ø > 1.762	1.751/1.749	Ø < 1.746
D	1.972/1.974	Ø > 1.976	1.965/1.963	Ø < 1.961
E	2.382/2.384	Ø > 2.386	2.375/2.373	Ø < 2.371

Table 6. Standard Design Pump Mechanical Seal Settings

Pump Model	Suction End (Inches) (from end of sleeve to face of collar)
A	3.100
B	3.100
C	3.100
D	4.322
E	4.807

Table 7. Optional Design Pump Mechanical Seal Settings

Pump Model	Discharge End (Seal Type 1) (for reference only) – Inches (from face of box to face of collar)	Discharge End (Seal Type 8B1) (for reference only) – Inches (from face of box to face of collar)	Suction end (Seal Type 1 or 21) - Inches (from face of box to face of collar)
A	.750	1.375	1.000
B	.750	1.375	1.000
C	.750	1.375	1.000
D	2.062	1.750	2.062
E	1.917	1.812	1.917

Table 8. Key Mechanical Data

Item	Pump Model			
	A, B	C	D	E
Maximum Speed	3500 RPM			
Max HP – (17-4 PH shaft)	370	370	603	900
Max HP – (416 SS Shaft)	308	308	500	690
WR ² of Rotor – 1 st Stage (lb-In ²)	14.6	30.8	36.7	106.5
WR ² of Rotor – each Stage (lb-In ²)	10.2	26.7	31.1	94.4
Lubrication Method (Standard)	Oil – ISO Grade 68			
L ₁₀ Bearing Life (hrs) - Thrust	50,000			
L ₁₀ Bearing Life (hrs) - Radial	50,000			
Radial Bearing Type	307	307	308	309
Thrust Bearing Type	7307	7307	7308	7309

The standard seal flush plans provided with the optional outboard mechanical seal are shown below.

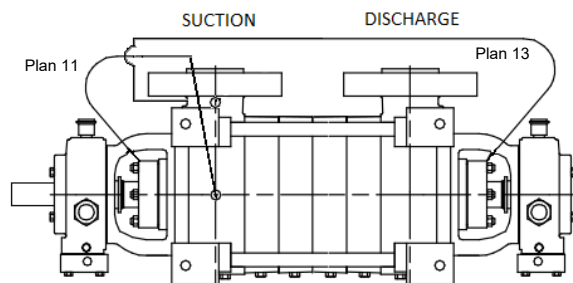

STANDARD PLAN 11/13

Recirculation from Suction Point to Seal

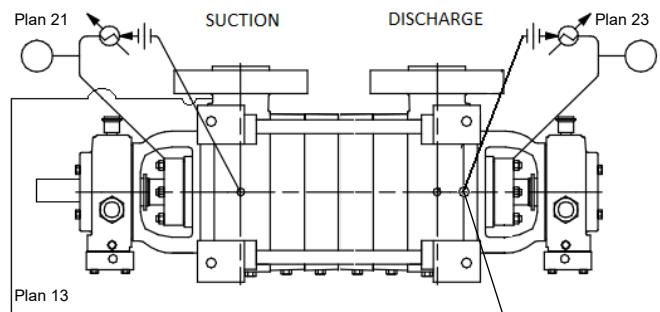

OPTIONAL PLAN 21/23/13

Recirculation from Discharge Point thru a TI and Heat Exchanger to Seal

Figure 2. Standard Seal Flush Plans

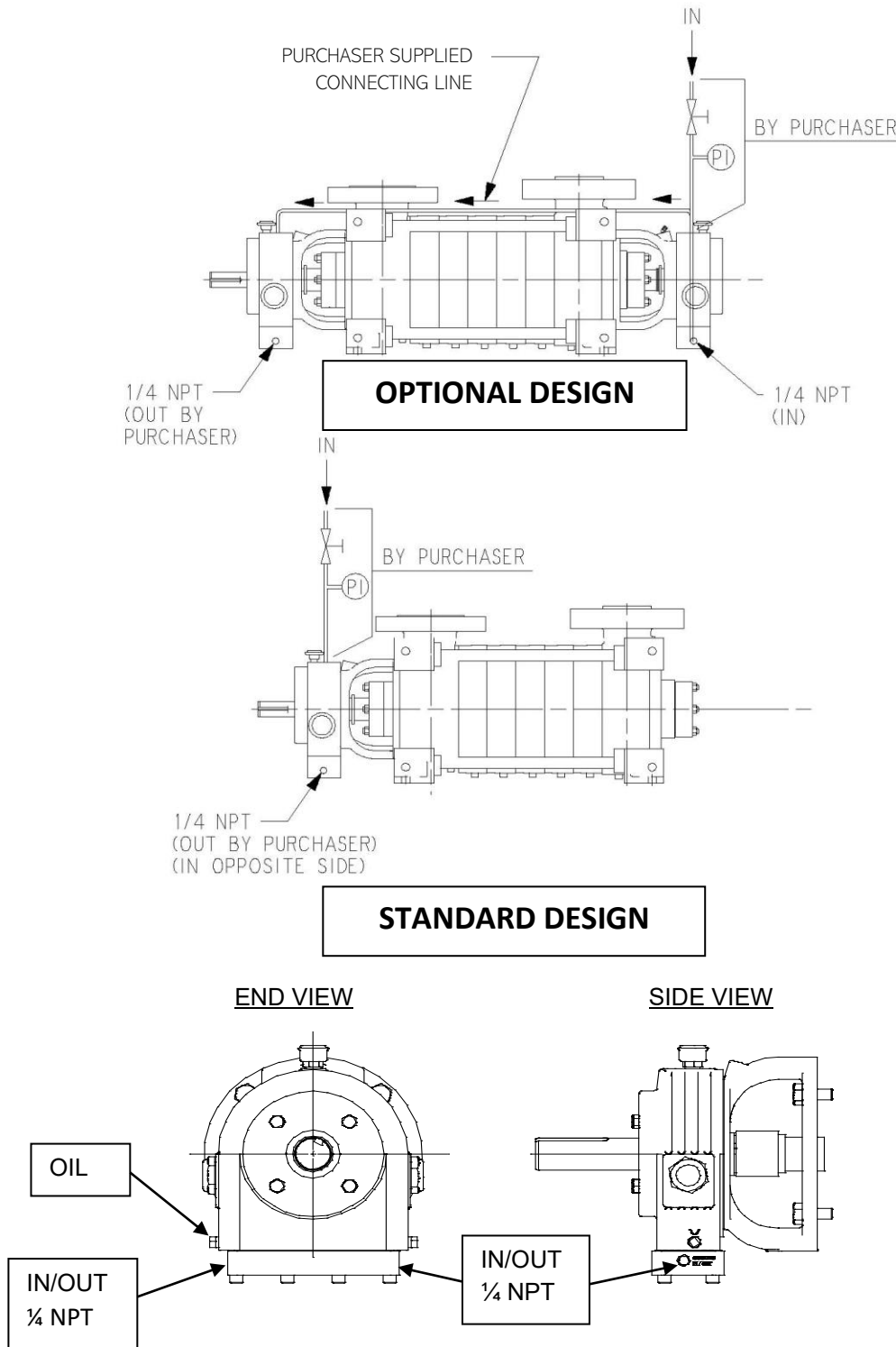
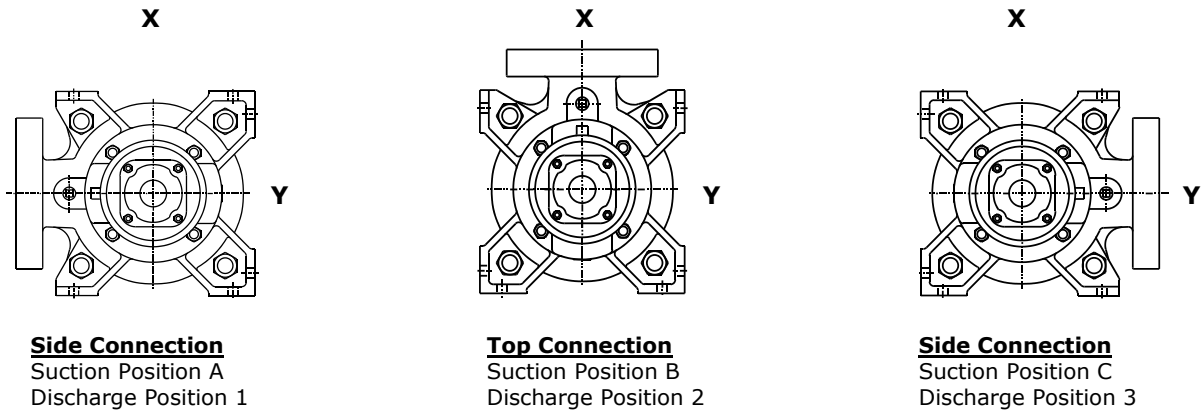

Figure 3. Bearing Frame Water Cooling

Table 9. Permissible Nozzle Loads



Size	Side Connection						Top Connection					
	F _X	F _Y	F _Z	M _X	M _Y	M _Z	F _X	F _Y	F _Z	M _X	M _Y	M _Z
A, B	256	555	567	643	839	370	710	232	732	552	839	266
C	266	573	595	746	988	414	710	244	778	649	988	311
D	399	822	827	1,290	1,599	801	1,130	352	997	1,083	1,599	565
E	599	1,228	1,281	2,361	3,003	1,411	1,673	530	1,575	2,007	3,003	1,011

M = Moments measured in Foot-Pounds (FT-lbs)

F = Forces measured in Pounds (lbs)

Table 10. Minimum Flow Rates RS-6 and RS-9

Pump Model	Speed (RPM)	Minimum Flow (GPM)	Minimum Continuous Flow (GPM)
A	1450	15	20
	1750	20	25
	2900	25	40
	3500	35	50
B	1450	15	40
	1750	20	50
	2900	25	80
	3500	35	100
C	1450	30	75
	1750	40	90
	2900	50	150
	3500	100	180
D	1450	30	125
	1750	50	150
	2900	120	250
	3500	200	300
E	1450	30	200
	1750	50	250
	2900	150	400
	3500	200	500

VI. INSPECTION AND STORAGE.



A. INSPECTION. Upon receipt of the shipment, unpack and inspect the pumping unit and individual parts to insure none are missing or damaged. Carefully inspect all boxes and packing material for loose parts before discarding them. Check to make sure the shipment complies with the purchase order. Immediately report any missing parts or damage incurred during shipment to the factory and to the Transportation Company and file your “damage and/or lost in shipment” claim with the carrier.

B. PACKING FOR RETURN. If the pumping unit is sent back to Carver Pump Company for repair, drain the unit, and re-seal all flanges and connections that were covered or plugged. Ship the pump(s) in an assembled condition to prevent damage to sealing faces of individual components. A Return Goods Authorization (RGA) and a Material Safety Data Sheet (MSDS) is required on all returned pumps. Copies of MSDS records should be kept and maintained by the customer. The customer is responsible for cleaning and flushing the pump before it is returned to the factory. Make sure to specify the fluid used in the service.

C. STORAGE OF PUMP. If the equipment is not to be immediately installed and operated, store it in a clean, dry, well ventilated place, free from vibrations, moisture and rapid or wide variations in temperature.

NOTE

Storage requirements vary depending on climatic environment, length of storage and equipment. For storage periods of three months or longer, contact manufacturer for specific instructions. Improper storage could damage equipment and would result in non-warranty covered restoration of non-warranty covered product failures.

When storing the pump up to three months rotate the shaft for several revolutions at least once per month to coat the bearings with lubricant, retard oxidation and corrosion, and prevent possible false brinelling.

The motor bearings should be prepared for storage according to the motor manufacturer’s instructions, in the motor manufacturer’s maintenance manual, which should come with the motor.

For shipment and long term storage purposes the pump ball bearing shall be fogged once every 30 days during storage with a rust retardant compatible with the oil used in the system to prevent rusting.

A pump which is made of iron or steel that sits in extreme heat, high humidity, or full or partially full water over 30 days will rust and will most likely seize. If the pump rusts and/or seizes, a complete overhaul and repair may be necessary to refurbish the pump.

Consider a unit to be in storage when:

1. It has been delivered to the job site and is waiting to be installed.
2. It has been installed but operation is delayed pending completion of construction.
3. There are long (30 days or more) periods between operating cycles.
4. The plant (or department) is shut down for periods of longer than 30 days.

Measures to be taken for prolonged shutdown of installed pumping unit. If the pumping unit remains installed a periodic check of operation is in order to make sure that the pump is always ready for instant start-up and to prevent the formation of deposits within the pump and the pump intake area. Start up the pumping unit regularly once a month or once every 3 months for a short time (approximately 5 minutes) during prolonged shutdown periods. Prior to operation check run ensure that there is sufficient liquid available for operating the pump.

Interim Storage (Indoors)/Preservation. When the unit is temporarily put into storage, only the wetted low alloy must be preserved. Commercially available preservatives can be used for this purpose. Please observe the manufacturer’s instructions for application/removal.

The unit/pump should be stored in a dry room where the atmospheric humidity is as constant as possible.

If stored outdoors, the unit and crates must be covered by waterproof material to avoid any contact with humidity.

Protect all stored goods against humidity, dirt, vermin and unauthorized access!

All openings of the assembled unit components are closed and must only be opened when required during installation.

All blank parts and surfaces of the pump are oiled or greased (silicone-free oil and grease) to protect them against corrosion.

VII. INSTALLATION.

A. LOCATION. The pump assembly should be located in an area that will permit periodic inspection and maintenance. Head room and access should be provided and all units should be installed in a dry location with adequate drainage. The discharge piping should be direct with as few elbows and fittings as possible.

The pump assembly should be installed as close to the fluid as possible. A short, direct suction pipe can be used to keep suction losses at a minimum. If possible, locate the pump so fluid will flow by gravity to the suction opening. The discharge piping should be direct with as few elbows and fittings as possible. The total Net Positive Suction Head Available (NPSHA), which includes the suction lift and pipe friction losses, must be greater than the Net Positive Suction Head Required (NPSHR) by the pump.

B. HANDLING.



CAUTION

Use a hoist with adequate lifting capacity.

Do not pick up the complete unit by the motor or the pump shafts or motor lifting eyes.

If the pumping unit slips out of the sling arrangement, it may cause injury to personnel and/or damage to the pumping unit.

Moving the unit requires proper preparation and handling. Always make sure that the pump or the pumping unit remains in a horizontal position while being moved and cannot slip out of the transport suspension arrangement. Use a sling for pumps without baseplates, refer to Figure 4. To lift a horizontal mounted unit, a hoist or suitable lifting device should be attached to each corner of base structure, refer to Figure 5. To lift a horizontal mounted unit, a hoist or suitable lifting device should be attached to each lifting lug on the base structure, refer to Figure 6. The individual motor may be lifted using proper eyebolts provided by the manufacturer, but these should not be used to lift the assembled unit.

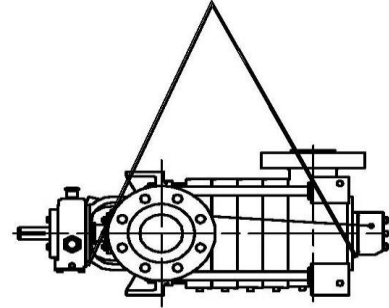

Figure 4. Sling Position for Moving Pump

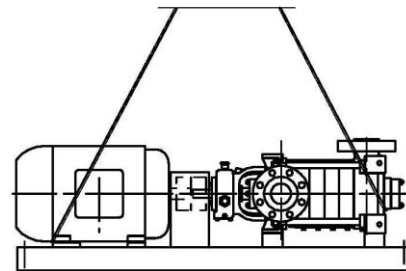

Figure 5. Sling Position for Moving Pumping Unit

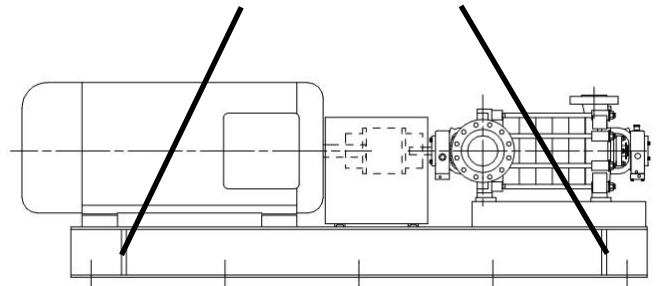

Figure 6. Sling Position for Moving Pumping Unit with Lifting Lugs

C. FOUNDATION. Make sure that the concrete foundation has set firmly before placing the unit on it. Its surface must be truly horizontal and even. The foundation bolts must be inserted in the base holes. The foundation should be 3 to 6 inches wider and longer than the base, have a level surface, and be of sufficient mass to prevent vibration and form a permanent rigid support for the unit. The best foundations are concrete with anchor bolts of adequate size embedded in the foundation in pipe sleeves having an inside diameter 2-1/2 times larger than the bolt diameter. This will allow for accurate positioning of the unit. Keep the concrete surface clean, yet rough.

Hydraulic Institute (HI) recommends a foundation capable of absorbing vibration at least five times the weight of the pumping unit and to form a permanent,

rigid support for the base plate. Consequently, maintaining the pump to driver alignment is important for a flexible coupled unit, refer to Figure 9. A concrete foundation on a solid base is recommended. Use foundation bolts of the proper size embedded into the concrete. A pipe sleeve larger in diameter than the bolt should be used. This allows movement for final positioning of the bolts; refer to Figure 7, Grouting and Foundation Bolting.

As soon as the pump and driver, mounted on a base, is placed on the foundation, remove the coupling guard and disconnect coupling halves. The base should be supported by the provided jacking screws. Refer to Figure 8; adjust the leveling screws until provided base. Verify that the pump and driver shafts are level. Check coupling faces, as well as suction and discharge flanges of the pump for horizontal or vertical positioning by means of a level. Make corrections, as necessary, by adjusting the leveling screws on the base.

D. LEVELING OF UNIT. When the pump is supplied complete with motor and base, the unit is assembled at the factory. Lower unit onto foundation, positioning base structure so anchor bolts are aligned in middle of holes in base.

The base should be supported on either rectangular metal blocks with shims or on metal wedges having a small taper. The support pieces should be placed close to the foundation bolts, refer to Figure 7, Grouting and Foundation Bolting. Place supports directly under the part of the base, which carries the greatest weight. Space the supports closely enough to provide uniform support of the base. Adjust the metal supports or wedges until the shaft is level. Check suction and discharge flanges of the pump by means of a level. Make corrections, as necessary, by adjusting the supports or wedges under the base.

The base should be supported on metal shims or metal wedges placed directly beneath the part of the base supporting the most weight. The shims or wedges should be spaced close enough to give support and stability.

Adjust metal supports or wedges until suction and discharge flanges are level.



Do not attempt to straighten the base by using the anchor bolts.

E. GROUTING. After the pumping unit has been leveled and the alignment is correct, grout the unit to the foundation using a high-grade, non-shrinking grout. Proceed grouting using the following procedure:

Prepare concrete foundations, anchor bolts and leveling screws according to individual instructions covering these items.

1. Wax forms heavily with at least three coats of paste wax. Forms must be substantial and well braced. All corners, joints, bottoms must be sealed with silicone caulk for water tightness. All forms should have a 45° chamfer strip installed to prevent stress risers.
2. Anchor bolt-free length must be wrapped with duct seal or electricians' plastic tape to prevent grout from contacting the bare metal. Grout sticking to the anchor bolt will prevent the elongation necessary to develop the hold-down force. Failure to do this will result in broken anchor bolts.
3. If equipped leveling screws must be greased to permit removal prior to the final torque.
4. Do not use shim packs as a leveling device unless it is planned to remove them prior to final torque application.
5. Leveling screw pads should be a minimum of 1/2" thick with minimum diameter of 3". Corners of pad must be rounded to approximately 1/8" radius to prevent stress cracking. Set leveling screws on the chipped concrete surface. Set the pad with quick set cement or resin repair compound. With jacking bolt pads secure and level, set and level base with leveling screws. If not equipped with leveling screws use shims to level.
6. The underside of the standard factory steel base plate was painted with epoxy grout primer and should only require proper cleaning. If the base must be sandblasted, prepare the contact faces to SSPC-SP 6 Spec. If base cannot be set within 24 hours of blasting, the underside must be coated with a compatible rust inhibitive primer. Tighten foundation bolts loosely. Allow the grout to fully cure before firmly tightening the foundation bolts.

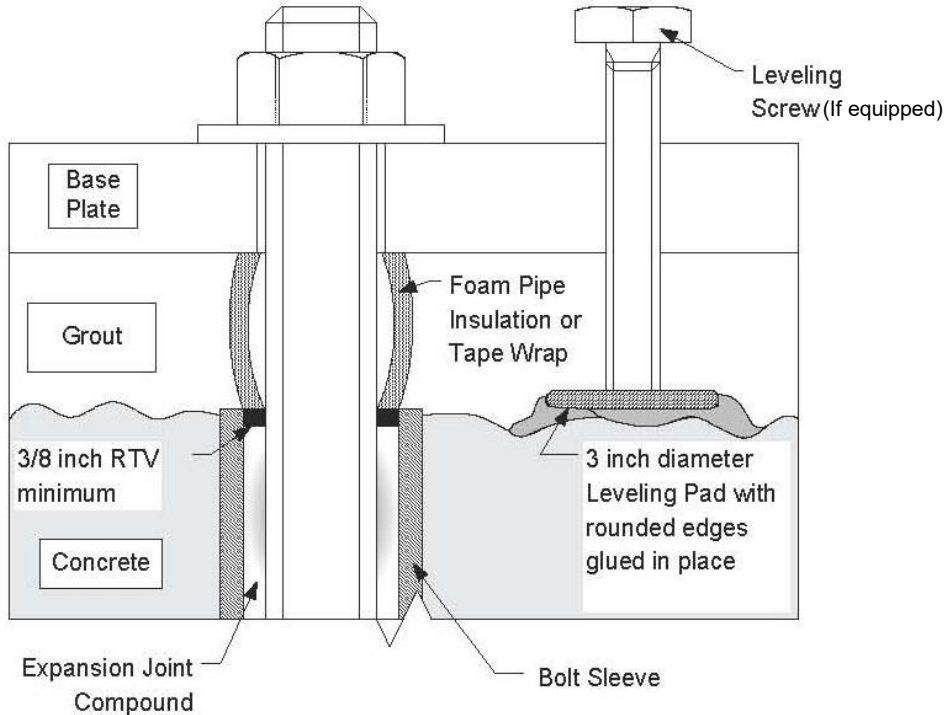

Figure 7. Grouting and Foundation Bolting

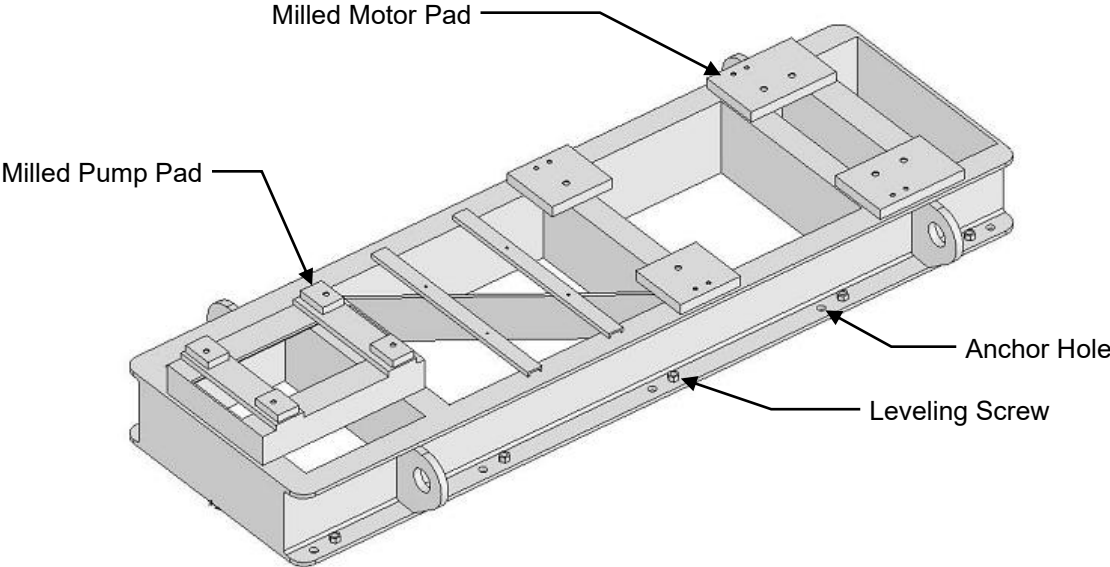

Figure 8. Unit Leveling

F. COUPLING ALIGNMENT. The pump and motor are connected by a coupling. Alignment is necessary when the pump or motor are removed from the base. The coupling should NOT be reconnected until the alignment has been completed. Always check the coupling alignment after shipping. The following is how to check the coupling alignment.

NOTE

Refer to coupling manufacturer’s manual for instructions regarding shaft alignment and recommended installation limits.

Soft Foot – The equipment must rest flat on its base. If one or more feet of the pump or motor are shorter, longer, or angled in some way to prevent uniform contact (a condition commonly known as “soft foot”) it must now be corrected.

To improve the life of the coupling, the shafts must be aligned to minimize deflection of the flexing elements. Shaft alignment is required in the axial, parallel, and angular directions, with each of these values not to exceed the recommended installation limits. Shaft alignment can be measured using various established methods, including Laser Alignment, Reverse Dial Indicator, and Rim and Face.

The motor and pump shafts must be accurately aligned as any misalignment can cause damage to the coupling, motor, or pump. When the shafts are in correct alignment, the coupling hubs will be on a common axis, concentric with each other, and at the correct distance apart. If the coupling hubs are misaligned, it is general practice to adjust the driver to the pump. Insert full

shims under the feet or supports of the motor and tighten fastening bolts until correct alignment is achieved.

1. Move the pump or motor to achieve acceptable alignment. When properly aligned, the disc packs will be centered and approximately parallel to their mating flange faces and the flexing elements will have little visible waviness when viewed from the side.

NOTE

Refer to the coupling manufacturer’s manual for recommended installation limits for Parallel, Angular, and Axial alignment.

2. The “Parallel Misalignment” value (P) is the offset between the centers of the hubs, as shown in Figure 9.
3. When the Parallel Offset is measured by rotating the hubs in unison with dial indicators as shown in Figure 9, the Total Indicator Reading (TIR) should be divided by (2) to calculate (P).
4. It should be noted that parallel offset measured on the hub surfaces includes misalignment of the equipment shafting plus any variation (TIR) in the hubs. This may be helpful to consider during problem solving for alignment difficulties.
5. The “Angular Misalignment” value is the maximum difference between the measurements X and Y taken at opposite ends of the hub flanges, as shown in Figure 9.

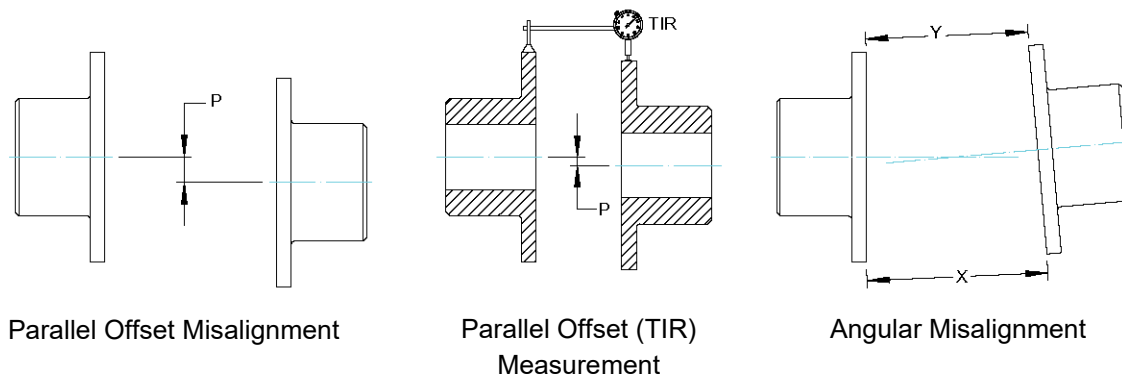

Figure 9. Coupling Alignment

G. PRE-INSTALLATION PROCEDURES.

1. Check the pump foundation and confirm the bolting surface is flat and the bolt pattern is correct.
2. Slowly lower pump onto the foundation.
3. Rotate the pump by hand. Check for any mechanical hesitation, binding or any acoustically transmitted signals from the pump. Hand rotation should be smooth and silent. Install the pump to foundation bolting and tighten to the system torque values. The pump should be rotated frequently during the procedure to tighten down the pumping unit.
4. After the pumping unit has been completely tightened down to the foundation, confirm that there is no binding.
5. Connect the piping.

H. PIPING. All piping should be independently supported near the pump so that pipe strain will not be transmitted to the pumping unit.

**CAUTION**

All piping connections must be made with the pipe in a freely supported state. Do not apply vertical or side pressure to align the piping with the pump flange.

Before connecting the suction, discharge, and auxiliary piping, check to see that the piping is absolutely clean internally. Any debris in the piping will be drawn into the pump passageways and can cause extreme damage. The internal diameters of the suction and discharge lines must be equal to the internal diameters of the pump suction and discharge nozzles.

The pump is shipped with flange covers to protect flange faces and to prevent foreign matter from entering the pump. Flange covers should remain intact until suction and discharge piping are connected to pump flanges.

Suction lift lines shall be laid with a rising slope toward the pump and suction headlines with a downward slope towards the pump.

The suction pipe must be airtight and sloped upward to pump flange to avoid air pockets which will impair pump operation. The discharge pipe should be as direct as possible using a minimum number of valves to reduce pipe friction losses.

Never use a straight taper (concentric) reducer in a horizontal suction line because air pockets may form in the top of the reducer and the pipe. Use an offset (eccentric) reducer instead.

It is recommended to install a check valve and closing valve in discharge line and closing valve in suction line, depending on the type of plant and pump. The check valve, between the pump and valve, protects pump from water hammer and prevents reverse rotation in the event of power failure. Closing valves are used in priming, starting, and pump shut down. Pump must never be throttled by use of a valve in the suction line.

Thermal expansions of the pipeline must be compensated by appropriate measures so as not to impose any extra loads on the pump exceeding the permissible pipeline forces and moments. Refer to Table 8 for permissible forces and moments.

The coupling should be realigned after installing piping or when hot service units are at the final operating temperature. Refer to Section VII, Paragraph F for coupling alignment.

I. AUXILIARY PIPING CONNECTIONS AND GAUGES.

In addition to primary piping connections, the pump may require other connections such as gauges or drains. All these lines and gauges should now be installed. Refer to Figure 2 and vendor mechanical seal drawing for seal line connections to the mechanical seal.

J. MOTOR. See motor vendor's manual for motor information and information on connecting to the power supply.

**CAUTION**

Connection to the power supply must be affected by a trained electrician only. Check available main voltage against the data on the motor rating plate and select appropriate start-up method.

K. DIRECTION OF ROTATION. Correct pump rotation is indicated by an arrow on the bearing frame. The standard direction of rotation, viewed from the motor end, is clockwise.

VIII. OPERATION.

A. PRE-START CAUTIONS.



CAUTION

Before activating the pumping unit, check to make sure there are no personnel working on the unit. Serious injury or death to personnel could result if the unit is activated while being worked on.

1. Before starting or operating the pump, read this entire manual, especially the following instructions.
2. Observe all caution or danger tags attached to the equipment.



CAUTION



Pumps are shipped without oil in the bearing frame and should be filled with oil before starting the pumping unit. Operation of the unit without proper lubrication can result in overheating of the ball bearings, ball bearing failures, pump seizures and actual breakup of the equipment, exposing operating personnel to injury.

3. Fill bearing frame with oil, refer to Section X, Paragraph A and Table 12. Pumps are shipped with no oil in the bearing frame.



CAUTION

Never run the pump dry. Close running fits within the pump are liquid lubricated. Dry running will result in pump seizure or damage.

4. Before starting the pump, fill the pump and suction line with liquid. The pump may be primed by using an ejector or vacuum pump.
5. Before starting a mechanical seal pump equipped with external flush lines, turn on mechanical seal water, and confirm the mechanical seal water is at sufficient pressure. Refer to Table 13 for minimum cooling flow rates.
6. Check final alignment of pump and driver. Both shafts must turn freely by hand. If necessary, check coupling alignment.

7. Jog starter switch on motor to check that the direction of rotation must agree with the arrow stamped on the pump frame or base.
8. Before starting the pump, install closed guards around all exposed rotating parts.
9. If excessive vibration or noise occurs during operation, shut the pump down and rotate shaft by hand. If excessive vibration or noise continues, consult a Carver representative.

B. PRIMING. Dry running a centrifugal pump can result in extensive damage and possible seizing. It is, therefore, imperative that the pump be primed prior to initial start-up and that prime must be maintained through subsequent start-stop cycles.

The priming procedure is different for positive and negative suction head systems. Follow the procedure listed below.

Positive Suction Head:

1. Open the vent on the highest point on the pump casing.
2. Open all suction valves.
3. Allow liquid to flow from vent hole until all air bubbles are vented. Then close the vent.
4. The pump is now primed.

Negative Suction Head:

1. Install an ejector or vacuum pump on the vent at the highest point on the casing.
2. Close the discharge valve.
3. Open the suction valve.
4. Start the ejector or vacuum pump.
5. Allow liquid to flow until a continuous flow is exhausted from ejector. Then close the valve to the vent.
6. The pump is now primed.

C. STARTING THE PUMP.



Do NOT operate pumping unit against a closed discharge system. If pump has any chance of seeing operation against a closed system, a bypass system allowing a minimum design flow should be installed. This bypass will be satisfactory for short periods of operation. For extended periods of operation, the bypass should be sized for the minimum continuous flow required by the pump, refer to Table 10. Refer to Section VIII, Paragraph E for minimum/maximum flow calculation.

1. Confirm pumping unit is ready to start. Complete Section VIII, Paragraphs A and B.
2. If unit is equipped with mechanical seal cooling lines, turn on mechanical seal cooling water.
3. Fully open the suction valve.
4. Open discharge valves slightly, about 1 to 1 ½ turns if pump is being started for the first time or from being turned off for overhaul. Start the pump.
5. Slowly open discharge valves and adjust pressure and flow to the appropriate operating conditions. Refer to pump nameplate and system operating procedures for design point condition.

D. TURBINE APPLICATIONS. For turbine applications, consult your local distributor or a representative from Carver Pump Company.

E. MINIMUM/MAXIMUM FLOW CALCULATION. Unless otherwise specified in the characteristic curves or on the data sheets, the following applies.

- $Q_{min} = 0.1 \times Q_{opt}$ for short operation
- $Q_{min} = 0.3 \times Q_{opt}$ for continuous operation
- $Q_{max} = 1.1 \times Q_{opt}$ for 2-pole operation
- $Q_{max} = 1.25 \times Q_{opt}$ for 4-pole operation
- $Q_{opt} =$ optimum efficiency

The data above refers to water and water-like liquids. However, if the physical properties of the fluids handled are different from water, the calculation formula below must be used to check if an additional heat build-up may lead to a dangerous temperature increase at the pump

surface. If necessary, the minimum flow must be increased.

$$T_o = T_f + \Delta T$$

$$\Delta T = \frac{g * H}{c * \eta} * (1 - \eta)$$

- c Specific heat [J / kg K]
- g Acceleration due to gravity [m/s²]
- H Pump head [m]
- T_f Temperature of fluid handled [°C]
- T_o Temperature of casing surface [°C]
- η Pump efficiency at duty point [-]
- Δ T Temperature difference [°C]

F. OPERATING CHECKS.

1. Check for undue vibration or noise. If any occurs and does not stop within a short period of time, turn off the pump. For determination of the cause and its remedy refer to Troubleshooting in Section IX or consult Carver Pump Company.
2. Check and record flow and pressure readings. The flow and pressure readings should be within the operating system guidelines and similar to number stamped on the pump nameplate.
3. Check and record power input to the motor.
4. Check for leakage at mechanical seals.

G. STOPPING THE PUMP.

1. If the pump is being stopped for overhaul, slowly close the discharge valve. Otherwise leave discharge valves set at condition.
2. Stop the pumping unit in accordance with the directions on the electrical power supply.
3. Tagout and lockout power to motor according to OSHA Standard 1910.147.
4. Close discharge and suction valves and any auxiliary fluid lines.
5. The pumping unit is now off.

H. INDEFINITE SHUTDOWN.



When pump is handling hazardous fluid, extreme care must be taken to ensure safety of personnel when attempting to drain pump and piping before disconnecting the pumping unit. Suitable protection devices should be used and/or protective clothing should be worn.

For shipment and long term storage purposes the pump ball bearing shall be fogged once every 30 days during storage with a rust retardant compatible with the oil used in the system to prevent rusting.

Refer to Figures 13, 14, and 15, for the location of parts identified by item numbers. Drain pump by removing the following: plugs (424) form the bottom of each interstage

case (111) and suction case (9), and plug (421) from discharge case (1) depending on design. If necessary, flush pump to remove corrosive or toxic pumpage. Collect and dispose of corrosive or toxic material appropriately. Drain oil from bearing frame by removing pipe plugs (426) from bearing caps (37). Drain all piping if there is a possibility of liquid freezing. Provide pump and driver with a protective cover.

IX. TROUBLESHOOTING OPERATING PROBLEMS.

If you have followed the installation and starting procedures outlined in this manual, the pump should provide reliable service and long life. However, if operating problems do occur; significant time and expense can be saved if you refer to Table 11 to eliminate the most common causes of those problems.

Immediate action to be taken before proceeding with corrective actions in Table 11 is to stop the pump, refer to Section VIII, Paragraph G.

Table 11. Pumping Unit Troubleshooting

SYMPTOM	PROBABLE CAUSE	CORRECTIVE ACTION
Failure to deliver liquid.	<ol style="list-style-type: none"> 1. Discharge head above shutoff. 2. Check valve stuck or improperly installed. 3. Impeller or suction line clogged. 4. Improperly installed impeller. 5. Incomplete priming or venting of pump or piping. 6. Valves are not fully open. 7. Excessive wear of internal parts. 	<ol style="list-style-type: none"> 1. Check pump rating against actual head condition. 2. Adjust and/or reverse valve. 3. Inspect suction line and impeller. Clean as necessary. 4. Disassemble pump and correct axial alignment of impeller. 5. Vent piping again carefully and prime pump. 6. Open valves and if necessary, lock valves open to prevent accidental closure. 7. Disassemble pump and replace worn parts.
Excessive power consumption.	<ol style="list-style-type: none"> 1. Head lower than rating: trying to pump too much liquid or operating at end of performance curve. 2. Specific gravity or viscosity of liquid is too high. 3. Mechanical defects such as binding rotating elements. 4. System head lower than design condition. 5. Incorrect impeller diameter. 	<ol style="list-style-type: none"> 1. Adjust pressure flow. 2. Check liquid temperature and adjust as necessary. 3. Check for excessive pipe strain. Check foundation bolting. Replace defective parts. 4. Adjust system head. Trim impellers to actual condition. 5. Replace impeller or trim impeller to correct diameter. Consult with Carver Pump before trimming impellers.

Table 11. Pumping Unit Troubleshooting - Continued

SYMPTOM	PROBABLE CAUSE	CORRECTIVE ACTION
Insufficient discharge or flow.	<ol style="list-style-type: none"> 1. Discharge head above shutoff. 2. Air or gases in liquid. 3. Impeller or suction partially clogged. 4. Wrong direction of rotation. 5. Specific gravity or viscosity of liquid is too high. 6. Incorrect impeller diameter. 	<ol style="list-style-type: none"> 1. Check pump rating against actual head condition. 2. Adjust and/or redesign suction system. Add liquid to system. 3. Inspect suction and impeller and clean as necessary. 4. Reverse direction of rotation. 5. Check liquid temperature and adjust as necessary. 6. Replace impeller or trim impeller to correct diameter. Consult with Carver Pump before trimming impeller.
Vibration excessive.	<ol style="list-style-type: none"> 1. Foundation bolting loose. 2. Coupling halves not properly oriented relative to each other. 3. Impeller partially blocked. 4. Wrong rotation. 5. Insufficient foundation. 6. Pipe strain. 7. Coupling key to motor or coupling key to pump is not correct length. 8. Motor improperly balanced. 	<ol style="list-style-type: none"> 1. Torque bolting to proper values. 2. Adjust coupling halves system relative to match marks. 3. Inspect impeller and clean as necessary. 4. Adjust direction of rotation. 5. Stiffen foundation as necessary. 6. Modify piping as necessary. 7. Replace with key of correct length. 8. Balance motor.
Leakage at casing joints.	<ol style="list-style-type: none"> 1. Tie bolts not sufficiently tightened. 2. O-rings damaged. 	<ol style="list-style-type: none"> 1. Release the pressure and tighten the tie bolts. 2. Replace O-rings.
Oil leak.	<ol style="list-style-type: none"> 1. Loose connection. 2. Defective oil seal. 3. Loose or defective gasket. 	<ol style="list-style-type: none"> 1. Tighten connectors. 2. Replace oil seal. 3. Tighten bolting and/or replace gasket.
Bearing temperature excessive.	<ol style="list-style-type: none"> 1. Lubrication, insufficient lubrication. 2. Defective ball bearing. 3. Pump/driver shafts are misaligned. 4. Piping causes pump to “warp”. 	<ol style="list-style-type: none"> 1. Lubricate according to Section X, Paragraph A. 2. Replace ball bearing. 3. Check coupling alignment. 4. Ensure piping transmits no stress to pump. Alter piping layout, if necessary. Realign pump and driver shafts.

X. MAINTENANCE.

Generally, the pump does not need continuous supervision. The pump should always run quietly and smoothly, without vibration. To ensure such operation, the following maintenance schedule should be applied at regular intervals during operation of the pump. Occasional visual checks are recommended. Data should be recorded periodically for each pump to keep track of maintenance which has been performed and to note operational problems. A sample maintenance record sheet is provided for this purpose at the front of this manual.



Regular inspection and service are essential for safe operation of the pump in ATEX applications.

NOTE

Parts marked with * are options or vary by pump or bearing frame size.

Daily Inspection:

- Visually inspect unit.
- Check bearing cooling flow rates, if applicable, refer to Table 13.
- Check for leakage at mechanical seal.
- Check that oil level is at center of bullseye, if applicable. If equipped with a constant level oiler*, check oil level in the constant level oiler and refill as required.

Weekly Inspection:

- Check power (amps) readings.
- Check pump discharge pressure. Prescribed operating discharge pressure should never drop below 90 percent of design point pressure.
- Check vibration on pump and driver bearings. Vibration should NOT exceed 1.5 of overall displacement (unfiltered) peak to peak mils (0.001") at 3600 RPM and 3.0 of overall displacement (unfiltered) peak to peak mils (0.001") at 1750 RPM.

Monthly Inspection:

- Check coupling alignment.
- If necessary, grease coupling, but DO NOT over grease.
- Check foundation bolts.

Semi-annual Inspection:

- Change oil. DO NOT add excess oil.
- Check coupling alignment due to settling of foundation.
- If stand-by pumps are installed, it is advisable to operate pumps on a rotational system to give each pump a periodic duty. This ensures that stand-by pumps will have periodic operation and always be in good condition for instant start-up.

50/300 Hours

- The first oil change should be carried out after 50 hours of operation. The second oil change should be carried out after 300 hours of operation

1000 Hours

- After the second oil change at 300 hours subsequent oil changes should be affected at intervals of 1000 hours of operation.



20,000 Hours - Overhaul

- For pump overhaul, complete Section XI, Service and Repair.

A. LUBRICATION OF PUMP BEARINGS.



CAUTION



Pumps are shipped without oil and bearing frames should be filled with oil before starting the pumping unit. Operation of the unit without proper lubrication can result in overheating of the bearings, bearing failures, pump seizures and actual breakup of the equipment, exposing operating personnel to injury.

Ball Bearings (16 and 18). The radial ball bearing and the thrust ball bearings are lubricated by oil in the bearing frame. The thrust ball bearings are installed back to back. Replace the ball bearings when disassembling the pumping unit for mechanical seal service. Refer to Figures 13, 14, and 15, for the location of parts identified by item numbers.

Fill the bearing frame (99) with oil (refer to Table 12 for oil recommendations) through the breather vent (405) until oil can be seen in the center of the oil view sight (143)*.

To change oil, unscrew oil cap pipe plug (425) in bearing caps (35 and 37) and drain oil. Flush bearing frame with petrol or benzol. Slowly rotate the shaft by hand during flushing. Replace oil cap pipe plug and fill

the bearing frame (99) with oil (refer to Table 12 for oil recommendations) through the breather vent (405) until oil can be seen in the center of the oil view sight (143)*.

Table 12. Oil Recommendations

Manufacturer	ISO Grade 68
Royal Purple	Synfilm 68
Texaco	Regal R&O 68
Phillips	Magnus Oil 68
Exxon	Teresstic 68
Mobil	DTE 16 M

**Table 13. Bearing Cooling Flow Rates
(30 PSIG MAX.)**

Temperature Range	Flow Rate
-20° to 225° F (-4° to 107° C)	Oil Lube - Air
225° to 285° F (107° to 140° C)	Oil-Lube – Water 1 Gallons per Minute (GPM)
285° to 300° F (140° to 148° C)	Oil-Lube – Water 2 GPM

***Constant Level Oiler.** If equipped with a constant level oiler, fill reservoir with oil, place thumb over spout, invert and screw reservoir into upper casting. Allow reservoir to empty, filling the bearing frame (Figure 10). Several fillings of the reservoir may be required before the actual oil level is reached. To avoid adding too much oil, never finish filling oil in bearing frame (99) through the vent breather (405) at top of the bearing frame. Never use lower casting only as a fill spout, always fill thru reservoir. When oil level is reached, no more oil will run out of the reservoir bottle. Use constant level oiler's glass sight to check oil level in bearing frame. When oil level is reached tighten the three setscrews on the side of the upper oiler. The constant level oiler (143) should be topped up as required during operation.

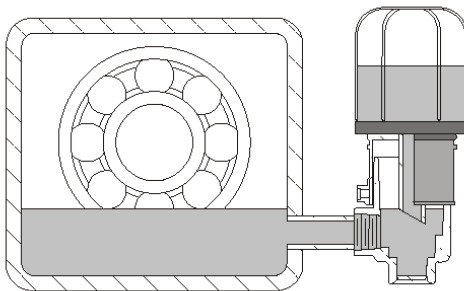

Figure 10. Constant Level Oiler

B. LUBRICATION OF MOTOR BEARINGS. See motor manufacturer's instructions to be sure motor bearings are properly lubricated.

C. TORQUE VALUES. Refer to Table 14, Recommended Torque Values. Clean and properly lubricate threads and bearing face of the fastener to obtain the proper fastener loading from these torque values. Fasteners should be tightened evenly and in stages with a crisscross bolt pattern. Refer to your torque wrench manual for the proper use of your wrench.

Refer to the pump nameplate to determine your pump model for tie rod torques.

The first bearing jam nut (22) is to have 20 ft-lbs torque while holding the coupling end of the shaft. The second bearing jam nut is to be tightened to 30 ft-lbs while holding the coupling end. Loctite the second bearing jam nut.

Table 14. Recommended Torque Values (ft-lbs)

Fastener Size	Torque Value
1/4-20 UNC	5
5/16-18 UNC	10
3/8-16 UNC	15
1/2-13 UNC	30
Bearing Jam Nuts	3/20/30*
RS6-A, B, C, D Tie Rod*	160
RS9-A, B, C, D Tie Rod*	315 / 50 ft-lbs increments
RS9-E Tie Rod*	446 / 50 ft-lbs increments

*(Refer to Section X, Paragraph C)

Table 15. Recommended Equipment

Tools	Materials	Test Equipment
Spanner Wrench Rawhide or Wood Mallet Wooden Wedge Allen Wrench Set Socket, Open, & Box Wrench Set Vice Grips Torque Wrench Jam Nut Wrench	Oil O-ring Lubricant	Coupling Alignment Gauges Volt-Amp Meter

XI. SERVICE AND REPAIR.

Refer to Figures 13, 14, and 15 to locate the pump parts by item number and parts list.

A. PREPARATIONS FOR DISASSEMBLY OF PUMP.

During disassembly, match mark parts so they can be replaced in their original position. All parts should be thoroughly cleaned or replaced with new, if necessary. Sealing faces should be perfectly clean.



CAUTION



Factory authorized parts must be used to safely maintain your Carver Pump.

NOTE

To avoid damage to O-rings, check to make sure all parts are free of sharp edges or burrs.

Parts marked with * are options or vary by pump or bearing frame size.

O-rings, ball bearings, oil seals/bearing isolators, mechanical seals and gaskets if disturbed from position should be replaced.

Close suction and/or discharge valves. The pump should be cooled down to ambient temperature. The casings must be empty and not under pressure.

After prolonged operation, components may not be easily removed from shaft. In such instances, rust solvent may be used and suitable extracting tools applied wherever possible. DO NOT use force under any circumstances. Refer to Table 15, Recommended Equipment, for proper tooling during disassembly and assembly. Refer to appropriate sectional drawing for location of parts followed by an item number.

Prepare the pumping unit for disassembly using the following list:

1. Read this entire section and study the applicable sectional view drawing and parts list before disassembling the pump.
2. Stop the pumping unit; refer to Section VIII, Paragraph G.



CAUTION

Before attempting to disassemble the pump, the electrical power supply to the driver must be locked and tagged in the “OFF” position to prevent injury or death to personnel servicing the pumping unit.



When pump is handling hazardous fluid, extreme care must be taken to ensure safety of personnel when attempting to drain pump and piping before disconnecting the pumping unit. Suitable protection devices should be used and/or protective clothing should be worn.

3. For cartridge mechanical seals (90* or 91*), reinstall seal clip.
4. Disconnect piping, gauge lines, and auxiliary connections, as necessary.
5. Drain pump by removing the following plugs: plug (424) from the bottom of each interstage case (111) and suction case (9), and plug (421*) from discharge case (1). If necessary, flush pump to remove corrosive or toxic pumpage. Collect and dispose of corrosive or toxic material appropriately.
6. Drain oil from bearing frame by removing pipe plugs (426) from bearing caps (37 and 37A*).
7. Confirm water from the oil cooler (215A*) is drained.
8. Disconnect all male connector retaining nuts from male connectors (410 and 561*) bodies, as applicable. Remove tubing (400 and 401), as applicable. Retaining nuts will remain with tubing.
9. Remove coupling guard and disconnect coupling halves.
10. Remove nuts and washers, as applicable from discharge (1) and suction casing feet (9) holding pump to base. Move the pump to a suitable work area for disassembly; refer to Section VII, Paragraph B for handling of the pump.

B. DISASSEMBLY OF PUMP WITH STANDARD SLEEVE BEARING.

The instructions that follow are an aid for properly trained personnel to service your Carver Pump. Refer to Figures 13 and 15 to locate the pump parts by item number and parts list. If a specific sectional assembly drawing exists for a particular job, then that drawing should be referred to for service work. Read this entire section before disassembling the pump.

NOTE

Parts marked with * are options that vary by pumping unit and bearing frame size.

ATEX and CE require bearing isolators and metal splash guards. Other customers may use oils seals and plastic splash guards. These items fit in the same positions.

Refer to Section II for Safety precautions before disassembling pump.

After completion of dismantling, all parts should be thoroughly cleaned or replaced by new ones if necessary. All gaskets and sealing faces should be perfectly clean. When cutting new gaskets, make sure they are exactly the same thickness as the old ones.



CAUTION

Use a hoist with adequate lifting capacity; refer to Section VII, Paragraph B.



When pump is handling hazardous fluid, extreme care must be taken to ensure safety of personnel when attempting to drain pump and piping before disconnecting the pumping unit. Suitable protection devices should be used and/or protective clothing should be worn.

NOTE

Pump should be dismantled from the discharge end. Mark or number each component while dismantling according to sequence.

1. Complete Section XI, Paragraph A before continuing with disassembly.
2. With pump in a horizontal position clamp down suction case (9) foot to steady pump during disassembly.
3. Support interstage casings (111) before dismantling to prevent from being dropped while discharge case (1) is removed.

4. Starting on the discharge side (Outboard) remove gland nuts (615) and gland washers (646) from the outboard bearing cap stud (631). Remove outboard bearing cap (37A) from the discharge case (1). Remove the gland O-ring (89H) from the outboard bearing cap.
5. Remove male connector (410) body from the seal gland (17A).
6. Remove hex nuts (615) and gland washer (646) from studs (630) on seal gland (17A). Slide back the seal gland from suction case (9) to release mechanical seal (90) tension.
7. Remove tie bolt nuts (616) and tie bolt washers (645). Remove tie bolts (173) connecting the discharge case (1) and the suction case (9).
8. Remove jam nuts (614) and shaft washer (28) from shaft (6).



CAUTION

Use a hoist with adequate lifting capacity for lifting the discharge case (1).

NOTE

The last stage bushing (63X), O-ring (89A), and the last stage diffuser (5X) with wear ring (7X) still intact will come off with the discharge case. Match mark impellers, sleeves, keys, interstage casings and casings according to sequence.

9. Remove discharge case (1) with sleeve bearing (63Y) still intact.
10. Remove the last stage diffuser (5X) with wear ring and last stage bushing (63X) still intact. Remove O-ring (89A) from the last stage bushing.

NOTE

Refer to Table 5, Sleeve Bearing Dimensions to determine if replacement of sleeve bearing (63Y) is required.

IMPORTANT: Check for shims between impellers and spacer sleeves.

11. If replacing sleeve bearing (63Y), remove sleeve bearing from discharge case (1).
12. Remove sleeve (14X) from shaft.
13. Remove impeller (2X) and impeller key (32A) from shaft.
14. Remove interstage casing (111) with casing O-ring (89D), diffuser (5A), diffuser bushing (63)

and wear ring (7X) intact. Remove casing O-ring from interstage casing and discard O-ring.

15. Remove impeller key (32A). Remove interstage sleeve (58). Remove interstage shims (73G), as necessary, from both sides of interstage sleeve. Record the location of all removed shims for ease of assembly.
16. Repeat steps 14 and 15 for each stage of the pump. Number and match mark all parts during removal.
17. Remove the spacer sleeve (14D).

NOTE

Before removing wear rings from casings inspect per Section XI, Paragraph D, step 9. Wear rings should only be removed for replacement, refer to Section XI, Paragraph G for wear ring replacement.

18. If replacement is required, remove wear ring (7X) and diffuser (5X). First wear ring (7A) will remain in the suction case (9) unless replacement is required.
19. Remove casing O-ring (89D) from suction case (9) and discard casing O-ring.

NOTE

Shaft (6), mechanical seal (90), seal gland (17A), bearing cap bearing isolator (168*), bearing frame bearing isolator (169*), and inboard bearing cap (37) will come off together with the bearing frame (99) as an assembly.

20. Remove bolts (600) from bearing frame (99). Remove bearing frame assembly from suction case (9).
21. Remove bolts (601), washer (850), O-ring (89W), and remove inboard bearing cap (37). Remove bearing cap bearing isolator (168*) from inboard bearing cap and discard bearing cap bearing isolator.
22. Remove bearing jam nuts (22) from shaft (6).
23. Remove back-to-back ball bearings (16) with bearing frame (99) from shaft (6).
24. Remove bearing spacer (78) with slinger (40) intact, from shaft (6). Remove bearing frame bearing isolator (169*) from bearing frame (99) and discard bearing frame bearing isolator.
25. Remove snap ring (176).

NOTE

Refer to mechanical seal vendor instructions for proper mechanical seal removal procedure.

DO NOT remove rotating element of mechanical seal (90) from shaft sleeve (14A) at this point, especially if mechanical seal is relatively clean and in good working condition.

26. For Type 1 mechanical seals (90*), remove gland (17A) from shaft (6).
27. Remove sleeve (14A) and rotating element of mechanical seal (90*) from shaft (6). Inspect rotating element of mechanical seal. If replacement is required, remove element from sleeve.
28. Remove O-ring (89X).
29. If necessary to replace mechanical seal (90*), remove stationary element of mechanical seal in seal gland (17A). Remove gland O-ring (89H) from seal gland and discard O-ring.
30. For cartridge mechanical seals (90*), loosen setscrews holding the cartridge seal sleeve to shaft (6). Remove cartridge seal from shaft.
31. Remove key (32X) from shaft (6).

NOTE

DO NOT remove seal collar (68), unless sleeve (14A) needs replaced.

32. Remove setscrews (665) from seal collar (68). Remove seal collar from sleeve (14A).

C. DISASSEMBLY OF PUMP WITH OPTIONAL MECHANICAL SEALS.

The instructions that follow are an aid for properly trained personnel to service your Carver Pump. Refer to Figures 14 and 15 to locate the pump parts by item number and parts list. If a specific sectional assembly drawing exists for a particular job then that drawing should be referred to for service work. Read this entire section before disassembling the pump.

NOTE

Parts marked with * are options that vary by pumping unit and bearing frame size.

ATEX and CE require bearing isolators and metal splash guards. Other customers may use oils seals and plastic splash guards. These items fit in the same positions.

Refer to Section II for Safety precautions before disassembling pump.

After completion of dismantling, all parts should be thoroughly cleaned or replaced by new ones if necessary. All gaskets and sealing faces should be perfectly clean. When cutting new gaskets, make sure they are exactly the same thickness as the old ones.



CAUTION

Use a hoist with adequate lifting capacity; refer to Section VII, Paragraph B.



When pump is handling hazardous fluid, extreme care must be taken to ensure safety of personnel when attempting to drain pump and piping before disconnecting the pumping unit. Suitable protection devices should be used and/or protective clothing should be worn.

NOTE

Pump should be dismantled from the suction end. Mark or number each component while dismantling according to sequence.

1. Complete Section XI, Paragraph A before continuing with disassembly.
2. With pump in a horizontal position clamp down discharge case (1) foot to steady pump during disassembly.
3. Support interstage casings (111) before dismantling to prevent from being dropped while suction case (9) is removed.

4. Remove male connectors (410 and 561*) bodies from seal glands (17A and 17X*).

NOTE

Refer to mechanical seal vendor instructions for proper mechanical seal removal procedure.

5. For cartridge mechanical seals (90*), loosen setscrews holding the cartridge seal sleeve to shaft (6) and remove cartridge seal.
6. For Type 1 mechanical seals (90*), remove nuts (615) and washers (646) from studs (630) on seal glands (17A and 17X). Slide back seal gland from suction casing (9) and discharge casing (1) to release mechanical seals (90 and 91) tension.
7. Starting on suction end (Inboard) remove bolts (601), washers (850), O-rings (89W) from bearing cap (37). Remove bearing cap (37) from inboard bearing frame (99). Bearing cap bearing isolator (168*) will be removed with bearing cap. Remove bearing cap bearing isolator and discard.
8. Remove bearing jam nuts (22) from shaft (6).

NOTE

Do not remove both bearing frames at the same time. Pump should be dismantled from the suction end.

9. Remove bearing frame bolts (600). Remove inboard bearing frame (99) from suction case (9). Ball bearing (16), spacer sleeve (14G), and bearing frame bearing isolator (169) will come off together with the inboard bearing frame. Discard ball bearing and bearing frame bearing isolator.
10. Remove slinger (40) from sleeve (14A). Remove seal gland (17A) and sleeve from shaft (6).

NOTE

DO NOT remove rotating element of mechanical seal (90*) from sleeve (14A) at this point, especially if mechanical seal is relatively clean and in good working condition.

11. If necessary to replace mechanical seal (90*), remove stationary element of mechanical seal in seal gland (17A). Remove gland O-ring (89H) from seal gland and discard O-ring.
12. For Type 1 mechanical seals (90*), remove sleeve (14A) with rotating element of mechanical seal (90*) from shaft (6). Inspect rotating element of mechanical seal. If replacement is required, remove rotating element from sleeve.
13. Remove tie bolt nuts (616) and tie bolt washers (645) from tie bolts (173). Remove tie bolts connecting the suction case (9) and the discharge case (1).



CAUTION

Use a hoist with adequate lifting capacity for lifting the suction case (9).

NOTE

Mark or number each component while dismantling according to sequence.

14. Remove suction casing (9). Remove sleeve key (32X) from shaft (6).

NOTE

Before removing wear rings from casings inspect per Section XI, Paragraph D, step 9. Wear rings should only be removed for replacement, refer to Section XI, Paragraph G for wear ring replacement.

15. First wear ring will remain in the suction case unless replacement is required. If replacement is required, remove first wear ring (7A) from suction case (9).
16. Remove casing O-ring (89D) from suction casing (9) and discard O-ring.

NOTE

IMPORTANT: Check for shims between impellers and spacer sleeves.

17. Remove sleeve O-ring (89X) from shaft (6) and discard O-ring. Remove spacer sleeve (14D) and first impeller (2A) from shaft.
18. Remove interstage case (111) with diffuser (5A), wear rings (7B and 7X), diffuser bushing (63), and casing O-ring (89D) intact. Remove O-ring from interstage case and discard O-ring.

NOTE

Before removing wear rings from casings inspect per Section XI, Paragraph D, step 9. Wear rings should only be removed for replacement, refer to Section XI, Paragraph G for wear ring replacement.

19. If replacement is required, remove wear rings (7B and 7X) and diffuser (5A).
20. Remove impeller key (32A) and interstage sleeve (58) from shaft (6). Remove interstage shims (73G), as necessary, from both sides of interstage sleeve (58). Record the location of all removed interstage shims for ease of assembly.
21. Remove interstage impeller (2X) from shaft (6).
22. Repeat steps 18 through 21 for each stage of the pump. Number and match mark impellers during removal.

NOTE

The last stage diffuser (5X), wear rings (7B and 7X), the last stage diffuser bushing (63X), and O-ring (89A) will come from the discharge casing together with the last stage diffuser.

23. Remove last stage diffuser (5X) from the discharge case (1). Remove O-ring from last stage diffuser bushing and discard O-ring. Remove spacer sleeve (14E) from shaft (6).
24. Remove bolts (600) from bearing frame (99) and discharge case (1).

NOTE

Shaft (6), mechanical seal (91*), seal gland (17X*), bearing cap (37), ball bearings (18), and bearing frame bearing isolators (169) will come off with outboard bearing frame (99).

25. Remove bearing frame (99) assembly.

26. Remove bearing cap bolts (601), bearing cap bolt washers (850), and bearing cap bolt O-ring (89W) from bearing cap (37) and discard O-ring. Remove bearing cap (37).

NOTE

If ball bearings and/or oil seals/bearing isolators are disturbed from position replace with new.

27. If necessary to remove back-to-back ball bearings (18), remove bearing jam nuts (22) from shaft (6).
28. Remove back-to-back ball bearings (18) and bearing frame bearing isolators (169*) with outboard bearing frame (99) from shaft (6). Discard bearing frame bearing isolators.
29. Remove bearing spacer (78) from shaft (6).
30. Remove snap ring (176) from shaft (6). Remove slinger (40X) from sleeve (14X).

NOTE

Refer to mechanical seal vendor instructions for proper mechanical seal removal procedure.

DO NOT remove rotating element of mechanical seal (91*) from shaft sleeve (14X) at this point, especially if mechanical seal is relatively clean and in good working condition.

31. For cartridge mechanical seals (91*), loosen setscrews that hold the cartridge seal sleeve to seal sleeve (14X) and remove cartridge seal.
32. For Type 1 mechanical seals (91*), remove seal gland (17X).
33. If necessary to replace mechanical seal (91*), remove stationary element of mechanical seal in seal gland (17X). Remove gland O-ring (89H) from seal gland.
34. Remove sleeve (14X) and rotating element of mechanical seal (91*) from the shaft (6). Inspect rotating element of mechanical seal. If replacement is required, remove rotating element from sleeve.
35. Remove key (32X) from shaft (6).

D. PARTS INSPECTION.

1. All parts should be thoroughly cleaned with a suitable solvent or replaced with new ones if necessary.
2. All sealing faces should be perfectly clean. All ball bearings, mechanical seals, gaskets, O-

rings, oil seals/bearing isolators, and locking devices with a nylock feature are to be replaced with new if disturbed from position.

3. Check shaft for runout, scratches, grooves, or any possible damage. Touch up scratches and grooves with a polishing cloth and inspect for remaining grooves or deep scratches. A bent or excessively damaged shaft should be replaced.
4. Inspect the discharge, interstage and suction casings for pitting, scoring, and erosion. The inside of the discharge, interstage and suction casings should be free of any pits or grooves. The maximum allowable depth is 1/8" (3mm). Replace the discharge, interstage or suction casings if any of these defects are present.
5. Inspect mechanical seal. Replace the mechanical seal that is disturbed from position or damaged.
6. Inspect impeller, sleeve, and coupling keys for distortion and push fit into keyways. The keys should be square on all four edges. They should fit without having to be forced. The keys should not rock in keyway. Replace keys or shaft if necessary.
7. Inspect tubing for kinking. Replace kinked tubing.
8. If the impeller shows excessive wear due to erosion or pitting, so that performance cannot be restored, it must be replaced. If a new impeller is installed, check to make sure that it is balanced and of the correct trim. If an impeller is restored or replaced, check the dynamic balance of the rotor before reassembly of the pump.
9. Check the wear ring clearance as follows:
 - a. Measure outside diameter of front impeller hub (2A or 2X) in three places.
 - b. Measure inside diameter of wear ring (7A) in three places.
 - c. If difference between the high reading of the inside diameter of the wear ring (7A) and the low reading of the outside diameter of the impeller (2A or 2X) wear ring exceeds the maximum recommended clearances given in Table 16, replace the wear ring according to Section XI, Paragraph G.
 - d. Measure outside diameter of back impeller hub (2A or 2X) in three places.
 - e. Measure inside diameter of the back wear ring (7X) in three places.
 - f. If difference between the high reading of the inside diameter of the back wear ring (7X)

and the low reading of the outside diameter of the back impeller (2A or 2X) wear ring exceeds the maximum recommended clearances given in Table 16, replace the back wear ring according to Section XI, Paragraph G.

10. Check rotor TIR and balance as follows:

- a. Check shaft TIR on roller bearing “V” blocks in (3) spots, coupling end, middle and discharge end of shaft.
- b. Install O-ring (89X) on suction end for standard design or discharge end for optional design. Install key (32X). Install the sleeve (14A, standard design or 14X, optional design).
- c. Install snap ring (176). Install bearing spacer (78). Install ball bearings (16, standard design or 18, optional design) back to back, meaning lettering on the outer race facing each other.
- d. Install first bearing jam nut (22) and torque to 3 ft/lbs. Install second bearing jam nut and torque to 30 ft/lbs. making sure that the first bearing jam nut does not tighten with the second bearing jam nut.
- e. Install spacer sleeve (14D, standard design or 14E, optional design) on shaft (6).
- f. Install impeller (2A, standard design or 2X, optional design). Install the interstage sleeve (58) on the shaft (6). Repeat until you have no more impellers to put on the shaft.
- g. Install sleeve (14X) on shaft (6). Install shaft washer (28, standard design) on shaft and first jam nut (614, standard design), torque jam nut to 30 ft/lbs. Note where the coupling shaft keyway is oriented. This is important to get the best rotor TIR.

- h. Check rotor TIR by placing an indicator on the impeller wear ring wearing surface and the interstage sleeves (58), rotate the shaft (6) slowly for reading. Rotor TIR must be .006 inch or less. Check coupling end of shaft to verify less than .003 inch TIR.
- i. To achieve the best TIR, loosen the jam nut (614, standard design), rotate shaft (6) 90 degrees, torque jam nut and recheck and record all TIRs again. When best TIR has been achieved, mark both ends of shaft with an arrow pointing down.
- j. Tape ball bearings (16, standard design or 18, optional design) so they don't spin on shaft (6) and are covered so no debris gets in during the balancing of the rotor.
- k. Dynamic balance rotor to G-6.3 spec.
- l. **IMPORTANT:** Mark all impellers, sleeves, interstage sleeve gaskets, and keys with numbers in the order they were staged while dismantling according to sequence for rotor balbance. Disassemble rotor.

Table 16. Maximum Recommended Wear Ring Clearance (Inches)

Pump Size	New Maximum Diametrical Clearance (Casing & Diffuser)
A	0.030
B	0.030
C	0.024
D	0.022
E	0.026

E. REASSEMBLY OF PUMP WITH STANDARD SLEEVE BEARING.

Read this entire section before reassembling the pump. The instructions that follow are an aid for properly trained personnel to assemble your Carver Pump. Refer to Figures 13 and 15 to locate the pump parts by item number and parts list. If a specific sectional assembly drawing exists for a particular job then that drawing should be referred to for assembly. Refer to Table 14 for recommended torque values. Assemble the pump in accordance with accepted rules of engineering practice. Coat individual components with a suitable lubricant before assembling. Assembly of unit should be performed on a clean, flat surface. During reassembly, install parts as applicable. Assembly begins at the suction (inboard end) of the pump.



CAUTION

During reassembly, install new O-rings, ball bearings, oil seals/bearing isolators, mechanical seals and gaskets if disturbed from position. O-rings, ball bearings, oil seals/bearing isolators, mechanical seals and gaskets may have been damaged during disassembly.

NOTE

All parts should be thoroughly cleaned or replaced with new ones if necessary. All sealing faces should be perfectly clean, but do not scratch or alter surface finish on seal faces.

Parts marked with * are options that vary by pumping unit and bearing frame size.

1. Confirm that the rotor TIR was completed per Section XI, Paragraph D, step 10 before proceeding with assembly. Secure suction casing (9) to work area.
2. Install sleeve key (32X) into keyway in shaft (6). Install sleeve O-ring (89X).

NOTE

DO NOT install mechanical seal (90*), only the seal collar (68*).

3. Slide sleeve (14A) onto end of shaft, lining up keyway of sleeve with sleeve key. Install seal collar (68*) to the scribe mark, refer to Table 6. Secure seal collar to sleeve (14A) with sleeve collar setscrews (665). Install snap ring (176) on the shaft.

4. Slide bearing spacer (78) onto end of shaft. Install slinger (40) on bearing spacer.



CAUTION

Handle inboard bearing frame bearing isolator (169) with care. Mishandling could damage faces of inboard bearing frame bearing isolator.

5. Install inboard bearing frame bearing isolator (169) in inboard bearing frame (99).



CAUTION

While installing back-to-back ball bearings, DO NOT unnecessarily hit ball bearings. If damage to ball bearings occurs, replace damaged ball bearings with new ball bearings.



After 20,000 Hours of service, replace the ball bearings.

6. Install new ball bearings (16) back-to-back in bearing frame (99); back to back meaning lettering on the outer race facing each other.
7. Slide bearing frame (99) and ball bearings (16) on the coupling end of the shaft (6) up to the bearing spacer (78).
8. The first bearing jam nut (22) is to have 3 ft-lbs torque while holding the coupling end of the shaft. The second bearing jam nut is to be tightened to 30 ft-lbs while holding the first jam nut. Install first jam nut (22) and temporarily torque to 3 ft-lbs. Add second jam nut and torque to 30 ft-lbs.
9. Temporarily secure inboard bearing cap (37) to bearing frame (99) with washers (850), and bolts (601).
10. Install bearing frame assembly through inboard side of suction casing (9). Confirm proper suction casing orientation and that wear ring (7A) is in suction casing.
11. Secure bearing frame (99) to suction casing (9) by tightening bolts (600).
12. Slide spacer sleeve (14D) onto outboard end of shaft (6), next to sleeve (14A).
13. Install impeller key (32A) into keyway on shaft (6). Confirm that wear ring (7X) is in interstage casing (111).

NOTE

Rotate pump to a vertical standing position using a fixture that holds the suction casing feet. This provides proper axial impeller alignment. This eliminates sag and helps with figuring compression due to the tie rod torquing.

Replace the same number of interstage sleeve gaskets (73G) during assembly that were removed during disassembly after the rotor TIR was completed per Section XI, Paragraph D, step 10.

IMPORTANT: Assemble shims/gaskets in the order they were disassembled only if no sleeves or impellers were replaced.

14. Slide first stage impeller (2A) onto shaft (6) from outboard end, fitting keyway of impeller to impeller key (32A) on shaft.

NOTE

Check alignment in accordance with Table 3, Axial Impeller Alignment Control Dimensions.

15. Install interstage sleeve (58) on shaft (6) from outboard end.
16. Lubricate and install new O-ring (89D) onto suction casing (9). Check to make sure wear ring and diffuser bushing (63) are in diffuser (5A). Install new lubricated O-ring (89D) in groove provided on interstage casing (111). Lightly tap diffuser into interstage casing. Confirm diffuser is sitting flat and the return vanes are missing nub in interstage casing.
17. Install interstage casing (111) assembly [diffuser (5A), wear ring (7X), diffuser bushing (63), wear ring (7B), and interstage sleeve (58)] over shaft (6) and fit onto suction casing (9). Confirm interstage casing drain plug is oriented on the bottom of pump and that the interstage casing assembly is sitting flat.
18. Install impeller key (32A) into keyway on shaft (6).
19. Install impeller (2X).
20. Check impeller (2X) alignment in accordance with Table 3.
21. Install interstage assembly [diffuser (5A), wear ring (7X), diffuser bushing (63), wear ring (7B),

and interstage sleeve (58)] onto previous interstage casing (111). Confirm interstage casing is sitting flat.

22. Repeat steps 18 through 21 for each stage up to the Nth stage ["N" depending on the number of stages of the pump (A,B,C,D, or E)]

NOTE

Refer to Figure 11, the front shroud of the impeller at the base of the wear ring surface hits on the previous stages interstage wear ring after the Nth stage (Refer to Table 17) and the correct Axial Impeller Alignment cannot be achieved (+/- .010"). The impeller/wear ring interference is due to the approximately .003" compression of each interstage casings when tightening the tie rods.

23. When there is no impeller/wear ring clearance there will be a gap between the impeller (2X) and sleeve (58) (Refer to Table 17). This gap must be measured and taken into consideration for the Axial Impeller Alignment setting.
 - a. Measure the gap by leaving out sleeve (58) and install impeller (2X).
 - b. Take a measurement the same way as checking for Axial Impeller Alignment and document.
 - c. Remove impeller and install sleeve.
 - d. Retake the measurement to see if sleeve is holding impeller up off of the previous interstage wear ring - this measurement should be more than the previous measurement and check for Axial Impeller Alignment.
 - e. If measurement is not higher, then remove impeller and add a .010" shim (73G), reinstall impeller and retake measurement and see if Axial Impeller Alignment measurement increases.
 - f. Continue adding and counting shims until measurement increases.
 - g. Repeat for remaining stages.

NOTE

Every gap that is left in the stack-up to achieve that stage final axial impeller alignment will compound to every stage after it and will have to be subtracted from all final axial impeller alignments.

Example – With Standard Sleeve Bearing

– RS9-A stage 11 Axial Impeller Alignment setting = .742”

Impeller without sleeve = .760” / With sleeve = .760” – No change

Add two shims = .020” – Measurement now at .765” – meaning .015” Gap between impeller and sleeve

Remove one shim = .010” – Measurement now at .760” minus the .005” Gap and minus the .005 Gap from stage 10 gives a Final = .750” Axial Impeller Alignment setting for stage 11 = Good due to +/- .010” tolerance.

Example – With Optional Mechanical Seal

RS9-A stage 15 Axial Impeller Alignment setting = (-.152”)

Impeller without sleeve = (-.135”) / With sleeve = (-.135”) – No change

Add two shims = .020” – Measurement now at (-.130”) – meaning .015” Gap between impeller and sleeve

Remove one shim = .010” – Measurement now at (-.135”) minus the .005” Gap and minus the .005 Gap from stage 14 gives me a Final = (-.145”) Axial Impeller Alignment setting for stage 15 = Good due to +/- .010” tolerance.

Table 17. Axial Alignment Worksheet

	Table 3. Axial Impeller Setting	Impeller with NO Sleeve Measurement	Impeller WITH Sleeve Measurement	Number of (.010”) Shims to Lift Impeller	Axial Impeller Alignment Measurement #2	Number of Shims Left out to Achieve Table 3 Setting	Gap left in Stack-up	Final Axial Impeller Alignment Setting	Shims to Remove
Stage 9									
Stage 10									
Stage 11									
Stage 12									
Stage 13									
Stage 14									
Stage 15									
Stage 16									
Stage 17									
Stage 18									

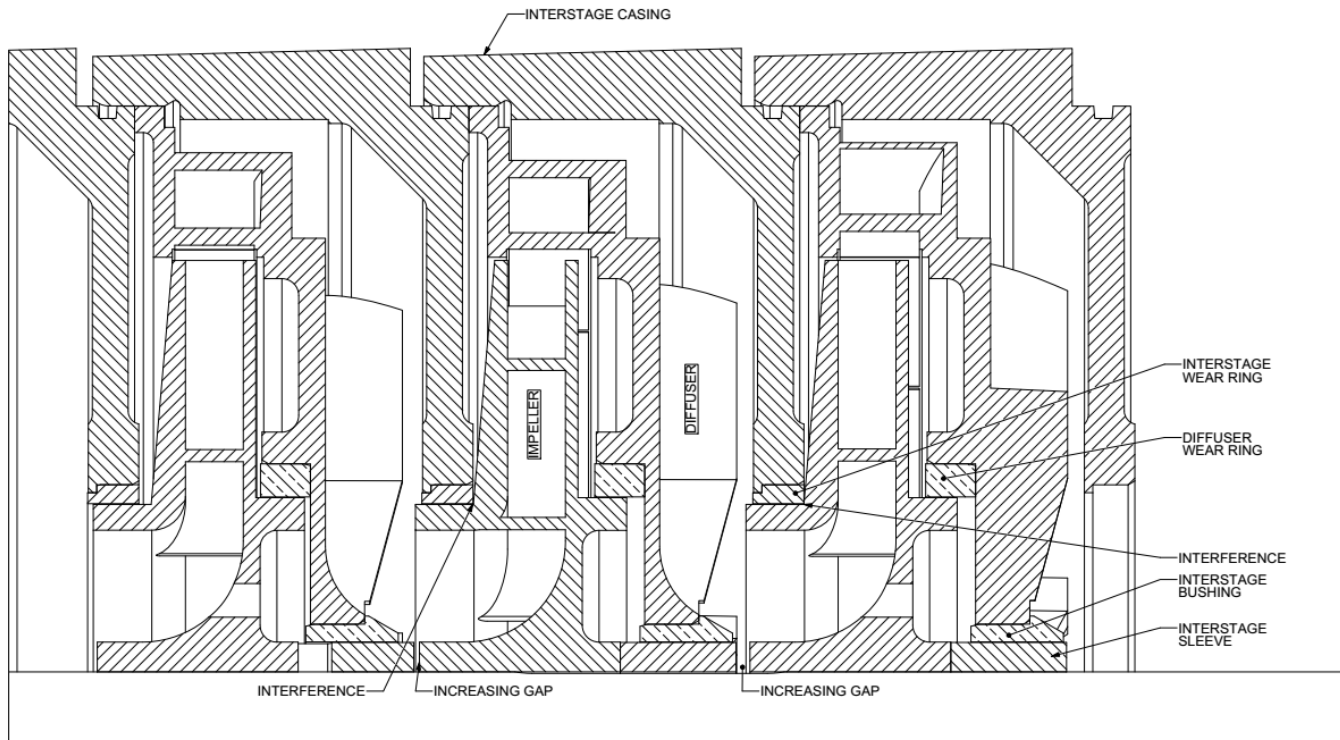

Figure 11. Bushing Not Torqued Interference

24. Remove interfering stages keeping close track of how many shims are between each stage.
25. Slide outboard sleeve (14X) onto outboard end of shaft (6), aligning keyway in sleeve with impeller key (32).
26. Install O-ring (89A) onto last stage diffuser bushing (63X). Install last stage diffuser bushing into last stage diffuser (5X), make sure that diffuser wear ring (7X) is installed in the last stage diffuser.

NOTE

Refer to Table 5, Sleeve Bearing Dimensions to determine if replacement of sleeve bearing (63Y) is required.

27. Install the last stage diffuser (5X) with last stage diffuser bushing (63X) and bushing O-ring (89A) into the discharge case (1). Install sleeve bearing (63Y) in discharge casing (1).
28. Install the discharge casing (1) with diffuser (5X), and wear ring (7X) on interstage casing (111). Confirm proper discharge casing orientation.
29. Install tie bolts (173), washers (645) and hex nuts (616) and torque to 50 ft/lbs temporarily.

NOTE

Remove pump from vertical position and place in horizontal position either on a milled flat surface or a pump base.

30. Loosen the tie bolt hex nuts (616) and tap with soft mallet both suction and discharge casings to make feet flat to the milled surface of the base.

NOTE

Ensure that the pump feet are on a milled flat surface or the base before tie rod hex nuts are torqued.

31. Tighten hex nuts (616) firmly and evenly. Refer to Table 14 for recommended torque requirements.
32. Sleeve (14X) should protrude .09 inch past the sleeve bearing (63Y), use shims to achieve gap.
33. Install shaft washer (28) on shaft (6).

NOTE

Rotate the shaft so the mark (arrow) that was put on during rotor TIR process is pointing down. Tap with a soft mallet along the suction, interstage and discharge casings. DO NOT rotate shaft until both end jam nuts have been torqued.

34. Install one jam nut (614) and torque to 20 ft/lbs. Use removable thread locker and install second jam nut (614) and torque to 30 ft/lbs.
35. Install new lubricated O-ring (89H) on outboard bearing cap (37A).
36. Secure outboard bearing cap (37A) to discharge casing (1) with nuts (615) and gland washers (646) on studs (631).

NOTE

Rotate shaft (6) by hand to ensure smooth rotation.

37. To install mechanical seal (90*), remove temporarily installed bearing cap bolts (601), bearing cap bolt washer (850), inboard bearing cap (37), and bearing jam nuts (22). Remove bearing frame bolts (600) and remove bearing frame (99) with ball bearings (16). Only remove snap ring (176) if snap ring is bigger than sleeve (14A). Loosen jam nuts (614) on end of shaft (6) to aid in snap ring removal. Torque jam nuts on end of shaft after torquing bearing jam nuts.

NOTE

Refer to mechanical seal vendor instructions for complete seal installation procedure.

38. If applicable, install cartridge mechanical seal (90*) on suction casing (9) with hex nuts (615) on studs (630). Do not remove seal clip until mechanical seal installation is complete. Center drill setscrews on cartridge mechanical seal to prevent cartridge mechanical seal sleeve from moving during operation.
39. For type 1 mechanical seals, lubricate both gland (17A) and stationary element (O-ring) of mechanical seal (90) with suitable lubricant. Insert stationary element of mechanical seal into gland. Install O-ring (89H) on gland and lubricate. Lubricate inside of suction casing stuffing box.

40. Install mechanical seal (90) rotating elements (mechanical seal spring retainer and spring). Install rubber bellow with rotating seal face by lubricating sleeve (14A) and inside rubber bellow of seal and push onto sleeve (14A) up to mechanical seal spring.
41. Install gland (17A*) on suction casing (9) and secure with gland washer (646) and gland nut (615). As applicable, ensure tap flush lines in gland are positioned so flush lines (400) can be connected.
42. Install snap ring (176), if removed in step 37, and bearing spacer (78) with slinger (40) on shaft (6).



CAUTION

While installing back-to-back ball bearings, DO NOT unnecessarily hit ball bearings. If damage to ball bearings occurs, replace damaged ball bearings with new ball bearings.



After 20,000 Hours of service, replace the ball bearings.

43. Install bearing frame (99) and secure with bearing frame bolts (600). Install new ball bearings (16) back-to-back in bearing frame (99); back to back meaning lettering on the outer race facing each other.

NOTE

Put removable thread locker on the second jam nut refer to Table 14 for recommended torque values.

44. If snap ring was removed to install mechanical seal (90*), torque first jam nut (22) to 3 ft/lbs., second jam nut with removable thread locker and torque to 30 ft/lbs. Install jam nuts (614) on shaft (6) and torque to 30 ft/lbs.
45. Install new bearing isolator (168) in bearing cap (37). Confirm that the breather vent (405), oil view sight (143), and plugs (426) are still installed in the bearing cap. Lubricate and install O-ring (89F) on bearing frame. Secure bearing cap to bearing frame (99) with bearing cap bolts (601), bearing cap bolt washers (850) and bearing cap bolt O-ring (89W).
46. Install tubing (400 and 401), as applicable. Secure tubing by tightening nuts on male tube

connector (410, 411 and 413) bodies, as applicable.

47. Install plugs (421, 423, 424, 426, and 429).
48. Rotate shaft (6) by hand to ensure shaft rotates freely. Tighten gland nuts (615) on gland (17A).

 **CAUTION**

Use a hoist with adequate lifting capacity; refer to Section VII, Paragraph B.

49. Return assembly to installation site. Install pump on base.
50. Check for soft foot, if needed correct by shimming or loosen and torque the tie bolts. Soft foot will cause alignment problems and may cause failure if not corrected. Secure pump with capscrews.
51. Rotate shaft (6) by hand to ensure shaft rotates freely and no rubbing noises are present.
52. Install coupling key (46). Install coupling half on pump shaft (6).
53. Align coupling according to Section VII, Paragraph F.
54. Reconnect piping, gauge lines, and auxiliary connections, as necessary. Check for smooth shaft rotation. Check alignment again. If different than before, you have pipe strain and must fix the pipe to eliminate the strain.
55. Reinstall coupling guard.

 **CAUTION**

 Pump bearing frames should be filled with oil before starting the pumping unit. Operation of the unit without proper lubrication can result in overheating of the ball bearings, ball bearing failures, pump seizures and actual breakup of the equipment, exposing operating personnel to injury.

56. Fill bearing frame with oil (refer to Section X, Paragraph A and Table 12).
57. Confirm water is turned on to external flush lines for pumps equipped with water cooling for either the oiler or the mechanical seal.
58. Remove all tags from valves and switches.
59. Start pumping unit in accordance with Section VIII, Paragraph C.

F. REASSEMBLY OF PUMP WITH OPTIONAL MECHANICAL SEALS.

Read this entire section before reassembling the pump. The instructions that follow are an aid for properly trained personnel to assemble your Carver Pump. Refer to Figures 14 and 15 to locate the pump parts by item number and parts list. If a specific sectional assembly drawing exists for a particular job then that drawing should be referred to for assembly. Refer to Table 14 for recommended torque values. Assemble the pump in accordance with accepted rules of engineering practice. Coat individual components with a suitable lubricant before assembling. Assembly of unit should be performed on a clean, flat surface. During reassembly, install parts as applicable. Assembly begins at the discharge (outboard end) of the pump.

 **CAUTION**

During reassembly, install new O-rings, ball bearings, oil seals/bearing isolators, mechanical seals and gaskets if disturbed from position. O-rings, ball bearings, oil seals/bearing isolators, mechanical seals and gaskets may have been damaged during disassembly.

NOTE

All parts should be thoroughly cleaned or replaced with new ones if necessary. All sealing faces should be perfectly clean, but do not scratch or alter surface finish on seal faces.

Parts marked with * are options that vary by pumping unit and bearing frame size.

1. Confirm that the rotor TIR was completed per Section XI, Paragraph D, step 10 before proceeding with assembly. Secure discharge casing (1) to work area.
2. Lubricate and install sleeve O-ring (89X) into groove on discharge end of shaft (6).
3. Install sleeve key (32X) into keyway in shaft (6). Lubricate inside of sleeve (14X) and slide onto shaft, lining up keyway of sleeve with sleeve key.
4. Install diffuser bushing O-ring (89A) on last stage diffuser bushing (63X). Install last stage diffuser (5X) with last stage diffuser bushing into discharge casing (1). Confirm gland studs (630) are installed in discharge casing.
5. Insert snap ring (176) in snap ring groove on shaft (6). Insert shaft assembly through discharge casing (1).

6. Install bearing spacer (78) onto shaft (6).
7. Install bearing frame bearing isolator (169*) into bearing frame (99).

**CAUTION**

While installing back-to-back ball bearings, DO NOT unnecessarily hit ball bearings. If damage to ball bearings occurs, replace damaged ball bearings with new ball bearings.



After 20,000 Hours of service, replace the ball bearings.

8. Install end of shaft (6) through outboard side of bearing frame (99).
9. Install new thrust ball bearings (18) back-to-back on shaft (6); back-to-back, meaning lettering on the outer race facing each other.
10. The first bearing jam nut (22) is to have 3 ft-lbs torque while holding the coupling end of the shaft. The second bearing jam nut is to be tightened to 30 ft-lbs while holding the first jam nut.
11. Temporarily install bearing cap (37) with bolts (601) on bearing frame (99). If removed, install bore plug (709).
12. Install bearing frame (99) with bearing frame bolts (600) confirm proper discharge orientation and drain on bottom side of bearing frame.
13. Install spacer sleeve (14E*) on shaft (6).
14. Install impeller key (32A). Make sure that wear ring (7X) is installed in diffuser (5X).

NOTE

Rotate pump to a vertical standing position using a fixture that holds the discharge casing feet for the purpose of proper axial impeller alignment. This eliminates sag and helps with figuring compression due to the tie rod torquing.

Check alignment in accordance with Table 3, Axial Impeller Alignment Control Dimensions.

15. Install the last stage impeller (2X). Check the depth reading in accordance with Table 3. If shimming is required for proper setting use interstage sleeve gaskets (73G), as necessary.
16. Install the next impeller key (32A) and interstage sleeve (58).

17. Lubricate and install new O-ring (89D) into interstage casing (111).
18. Install diffuser assembly [diffuser (5A), wear ring (7X), diffuser bushing (63), and wear ring (7B)] into interstage casing (111). Confirm diffuser sits flat in interstage casing.
19. Install interstage casing (111) into discharge casing (1).
20. Install the next stage impeller (2X) and impeller key (32A).
21. Repeat steps 15 through 20 for each stage up to the Nth stage [depending on the RS model (A, B, C, D, or E)].

NOTE

Refer to Figure 12, the back shroud of the impeller by the wear ring surface will start to hit on the diffuser wear ring face and diffuser (Refer to Table 17) and Axial Impeller Alignment cannot be achieved (+/- .010"). The impeller/ wear ring interference is due to the proximately .003" compression per interstage casings when tightening the tie rods.

22. When there is no clearance between the impeller back shroud corner by the wear ring surface area and the diffuser, there will be a gap between the impeller (2X) and sleeve (58) (Refer to Table 17). This gap must be measured and taken into consideration for the Axial Impeller Alignment setting.
 - a. Measure the gap by leaving out sleeve (58) and install impeller (2X).
 - b. Take a measurement the same way as checking for Axial Impeller Alignment and document.
 - c. Remove impeller and install sleeve.
 - d. Retake measurement to see if sleeve is holding impeller up off the diffuser - this measurement should be more than the previous measurement and check for Axial Impeller Alignment.
 - e. If measurement is not higher, then remove impeller and add a .010" shim (73G), reinstall impeller and retake measurement and see if Axial Impeller Alignment measurement increases.
 - f. Continue adding and counting shims until measurement increases.
 - g. Repeat for next stages.

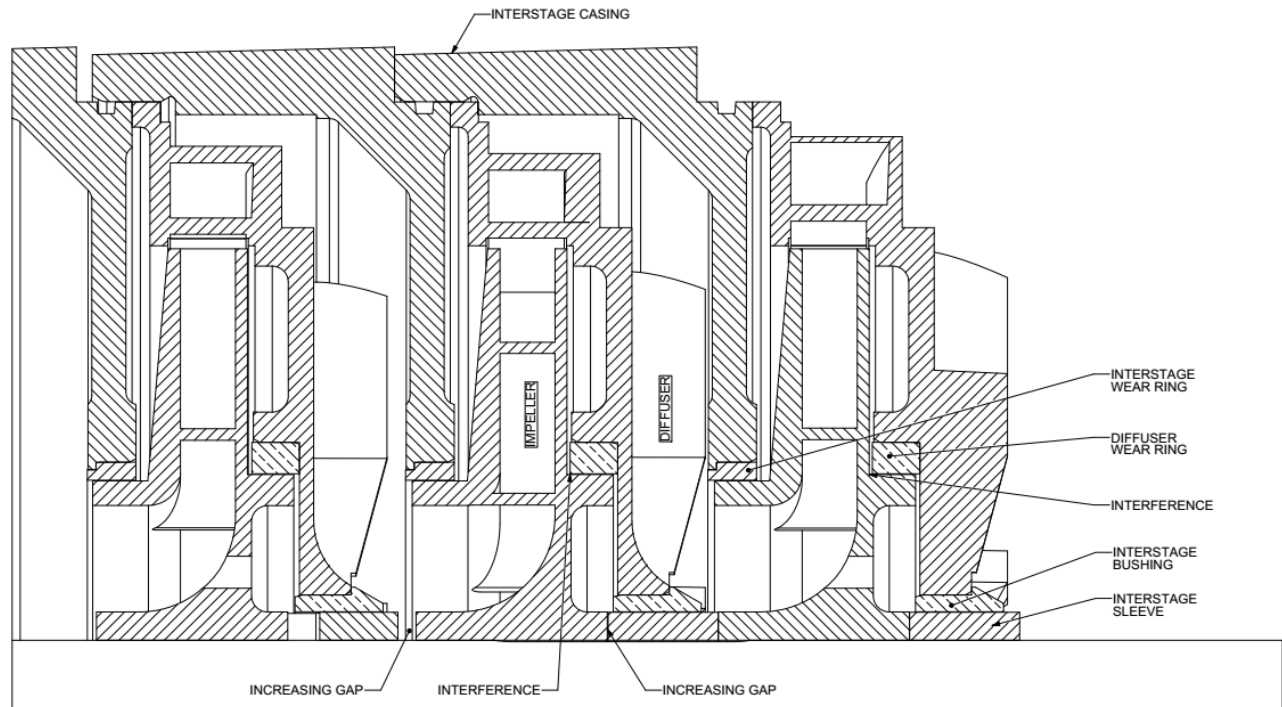

Figure 12. Tie Rods Not Torqued Interference

NOTE

Every gap that is left in the stack-up to achieve that stage final axial impeller alignment will compound to every stage after it and will have to be subtracted from all final axial impeller alignments.

23. Install spacer sleeve (14D) onto shaft (6).
24. Install key (32X) into keyway on shaft (6).
25. Mark shaft (6) and end of sleeve (14A) to determine location of key aligning key to keyway.
26. Lubricate and install sleeve O-ring (89X) and slide into groove on shaft (6).
27. Install sleeve (14A) onto shaft (6).
28. Lubricate and install casing O-ring (89D) onto suction casing (9).
29. Install suction casing (9) and tap into place against interstage casing (111), insure proper flange orientation of suction casing. Confirm gland studs (630) are installed in suction casing.
30. Install tie bolts (173), flat washers (645) and tie bolt hex nuts (616) and temporarily torque hex nuts to 50 ft/lbs.
31. Install spacer sleeve (14G). Install bearing frame (99) on suction casing (9) temporarily with

two bolts (600). Install bearing (16) and install one jam nut (22), leave loose.

NOTE

Remove pump from vertical position and place in horizontal position either on a milled flat surface or a pump base.

32. Loosen the tie bolt hex nuts (616) and tap with soft mallet both suction and discharge casing feet flat to the milled surface or the base.

NOTE

Ensure that the pump feet are on a milled flat surface or the base before tie rod hex nuts are torqued.

33. Tighten tie bolt hex nuts (616) firmly and evenly. Refer to Table 14 for recommended torque requirements.

NOTE

Rotate the shaft so the mark (arrow) that was put on during rotor TIR process is pointing down. Tap with a soft mallet along the suction, interstage and discharge casings. DO NOT rotate shaft until both end jam nuts have been torqued.

34. Torque bearing jam nut (22) to 20 ft/lbs on suction end. Rotate pump shaft to insure shaft spins freely.
35. To install mechanical seals, remove bearing jam nut (22) on suction end of pump. Remove bearing frame (99); inboard ball bearing (16), bearing isolator (169), and spacer sleeve (78) can stay in bearing frame.

NOTE

DO NOT rotate shaft during mechanical seal installation. Refer to mechanical seal vendor instructions for complete seal installation procedure.

36. If applicable, install cartridge mechanical seal (90*) on suction casing (9) with hex nuts (615) on studs (630). Remove seal clip after pump assembly is complete.
37. If applicable, for Type 1 mechanical seals determine placement of seal collar (68*) on sleeve (14A), refer to Table 7. For Installation of mechanical seal (90*) rotating element, refer to the following procedure:
 - a. Scribe a mark on the sleeve (14A) flush with stuffing box face. Remove sleeve making sure sleeve key (32X) stays in shaft (6) keyway. Refer to Table 7, Standard Mechanical Seal Settings, for specified distance and make a second scribe mark.
 - b. Install seal collar (68*) face to the second scribe mark. Secure seal collar to shaft sleeve (14A) with setscrews (665) using Loctite to secure seal collar.
38. Lubricate inside of sleeve (14A).
39. Align keyway to mark scribed in step 25.
40. Slide sleeve (14A) over sleeve O-ring (89X).
41. If stationary element of mechanical seal is replaced, clean, dry, and lubricate inboard gland (17A*).
42. Lubricate both inboard gland (17A*), stationary element, and O-ring of mechanical seal (90*) with suitable lubricant. Insert stationary element

of mechanical seal (90*) into inboard gland. Lubricate and install gland O-ring (89H*) on inboard gland (17A).

43. Lubricate and install rotating elements (rubber bellow) of mechanical seal (90*) onto sleeve (14A).
44. Slide inboard gland (17A*) with stationary elements of mechanical seal (90*) over end of shaft (6) onto suction casing (9) with studs (630) and nuts (615) finger tight. As applicable, ensure tap flush lines in inboard gland (17A*) is positioned so flush lines can be connected.
45. If removed install slinger (40) on sleeve (14A).

**CAUTION**

Handle inboard bearing isolator (169) with care. Mishandling could damage faces of inboard bearing isolator.

46. Install bearing frame bearing isolator (169) in bearing frame (99).
47. Secure bearing frame (99) to suction casing (9) by tightening bolts (600).

**CAUTION**

While installing radial ball bearings, do NOT unnecessarily hit bearings. If damage to ball bearings occurs, replace damaged ball bearings with new ball bearings.



After 20,000 Hours of service, replace the ball bearings.

48. Install new radial ball bearing (16) on shaft (6).

NOTE

Confirm the shaft, so the mark (arrow) that was put on during rotor TIR process is still pointing down. DO NOT rotate shaft until both end jam nuts have been torqued.

49. Install one jam nut (22) and torque to 20 ft/lbs. Use removable thread locker and install second jam nut and torque to 30 ft/lbs.
50. Install new bearing cap bearing isolator (168) in bearing cap (37). Confirm that the breather vent (405), oil view sight (143), and plugs (426) are still installed in the bearing cap. Lubricate and install O-ring (89F) on bearing frame. Secure

bearing cap to bearing frame (99) with bearing cap bolts (601). Bearing cap bolt O-ring (89W), and washers (850).

51. Refer to Figure 15 for units that are oil lube/water cooled or oil lube/air cooled for proper installation of oil cooler (215A).
52. Use proper gasket shellac in between oil cooler (215A) and/or gasket (73)/oil pan (215).
53. Repeat steps 34 through 50 for discharge end of pump.
54. Rotate shaft (6) by hand to ensure shaft rotates freely and no rubbing noises are present. Tighten gland nuts (615) on seal gland (17A*).
55. Install tubing flush lines.
56. Install plugs (424) for stuffing box, (423) for gauge connector, and (424) for the casing drain.



CAUTION

Use a hoist with adequate lifting capacity; refer to Section VII, Paragraph B.

57. Return assembly to installation site. Install pump on base.
58. Check for soft foot, if needed correct by shimming or loosen and torque the tie bolts. Soft foot will cause alignment problems and may cause failure if not corrected. Secure to base with capscrews.
59. Rotate shaft (6) by hand to ensure shaft rotates freely and no rubbing noises are present.
60. Install coupling key (46). Install coupling half on pump shaft (6).
61. Align coupling according to Section VII, Paragraph F.
62. Reconnect piping, gauge lines, and auxiliary connections, as necessary. Check for smooth shaft rotation. Check alignment again. If different than before, you have pipe strain and must fix the pipe to eliminate the strain.
63. Reinstall coupling guard.



CAUTION



Pump bearing frames should be filled with oil before starting the pumping unit. Operation of the unit without proper lubrication can result in overheating of the ball bearings, ball bearing failures, pump seizures and actual breakup of the equipment, exposing operating personnel to injury.

64. Fill bearing frame with oil (refer to Section X, Paragraph A and Table 12).
65. Confirm water is turned on to external flush lines for pumps equipped with water cooling for either the oiler or the mechanical seal.
66. Remove all tags from valves and switches.
67. Start pumping unit in accordance with Section VIII, Paragraph C.

G. REPLACEMENT OF WEAR RING. The pump has replaceable wear rings (7A, 7B and 7X) inserted into the diffuser (5A or 5X), suction casing (9), and interstage casing (111). The clearance between the wear ring and impeller hub will increase with wear. Internal leakage will result and pump performance will decrease. The allowable clearance and method of measurement is described in Section XI, Paragraph D.

NOTE

Parts marked with * are options that vary by pumping unit and bearing frame size.

Refer to Section II for Safety precautions before disassembling pump.

For pumps with hardened metal wear rings the impellers need replaced if not within the specified clearance listed in Table 18.

Suction Case Wear Ring (7A).

The suction case (9) must be removed from the base to replace the first stage wear ring (7A). To replace the first stage wear ring (7A) follow these steps:



When pump is handling hazardous fluid, extreme care must be taken to ensure safety of personnel when attempting to drain pump and piping before disconnecting the pumping unit. Suitable protection devices should be used and/or protective clothing should be worn.

1. Disassemble pump per Section XI, Paragraph C, steps 1 through 15.
2. Remove suction case (9) from base and take suction case and first stage impeller (2A) to a work area with access to machine shop equipment.
3. Remove the first wear ring (7A) from the suction case (9). This can best be accomplished on a lathe for composite wear rings. Hardened metal wear ring can be pried out of case.
4. Press the new first wear ring (7A) into the suction case (9). The beveled edge of the first wear ring is installed away from the first stage impeller (2A).
5. Place impeller (2A) on an arbor and mount between centers in a lathe or a grinder. Indicate front outside impeller hub to within 0.002 TIR maximum to be sure the arbor and impeller are running square.
6. Turn the front outside wear ring surface of the impeller (2A) until a 63 RMS or better finish is obtained.
7. Measure the outside diameter of the front impeller wearing surface and record this value. See measurement instructions in Section XI, Paragraph D.
8. Mount the suction case (9) with new first wear ring (7A) installed in a lathe. Indicate female rabbet to within 0.002 TIR maximum.

NOTE

When replacing first wear ring with the standard first wear ring, (part number beginning with "00") machining in step 9 is not required. When replacing first wear ring with the undersize first wear ring (part number beginning with "US") machining in step 9 is required.

9. If replacing with an undersized wear ring, bore wear ring (7A) to within the specified tolerance listed in Table 18 over the recorded size of the outside diameter of the front impeller wearing surface.
10. Reinstall suction case (9) on base.
11. Reassemble pump. Refer to Section XI, Paragraph F, steps 18 through 65.

**Table 18. New Wear Ring
Diametrical Clearance Limits (Inches)**

Pump Size	Casing Limits	Diffuser Limits
A	0.007 to 0.015	0.007 to 0.015
B	0.007 to 0.015	0.007 to 0.015
C	0.006 to 0.012	0.006 to 0.012
D	0.005 to 0.011	0.005 to 0.011
E	0.007 to 0.013	0.007 to 0.013

Diffuser Wear Ring (7X).



When pump is handling hazardous fluid, extreme care must be taken to ensure safety of personnel when attempting to drain pump and piping before disconnecting the pumping unit. Suitable protection devices should be used and/or protective clothing should be worn.

1. Complete Section XI, Paragraph C, steps 1 through 15 before continuing.
2. Remove interstage case (111) with front wear ring (7X) still installed and the impeller (2X) to a work area with access to machine shop equipment.
3. Remove the front wear ring (7X) from the interstage case (111). This can best be accomplished on a lathe for composite wear rings. Hardened metal wear rings can be pried out of case.
4. Press the new front wear ring (7X) into the interstage case (111).

5. Place impeller (2X) on an arbor and mount between centers in a lathe or a grinder. Indicate front outside impeller hub to within 0.002 TIR maximum to be sure the arbor and impeller are running square.
6. Turn the front outside wear ring surface of the impeller (2X) until a 63 RMS or better finish is obtained.
7. Measure the outside diameter of the front impeller wearing surface and record this value. See measurement instructions in Section XI, Paragraph D.
8. Mount the interstage case (111) with new front wear ring (7X) installed in a lathe. Indicate female rabbet to within 0.002 TIR maximum.

NOTE

When replacing front wear ring with the standard front wear ring, (part number beginning with "00") machining in step 9 is not required. When replacing front wear ring with the undersize front wear ring (part number beginning with "US") machining in step 9 is required.

9. If replacing with an undersized front wear ring, bore wear ring (7X) to within the specified tolerance listed in Table 18 over the recorded size of the outside diameter of the back impeller wearing surface.
10. Reassemble pump. Refer to Section XI, Paragraph F, steps 18 through 65.

Interstage Case Wear Ring (7B).



When pump is handling hazardous fluid, extreme care must be taken to ensure safety of personnel when attempting to drain pump and piping before disconnecting the pumping unit. Suitable protection devices should be used and/or protective clothing should be worn.

1. Complete Section XI, Paragraph C, steps 1 through 15 before continuing.
2. Remove interstage case (111) with back wear ring (7X) still installed and the impeller (2X) to a work area with access to machine shop equipment.
3. Remove the back wear ring (7X) from the interstage case (111). This can best be

accomplished on a lathe for composite wear rings. Hardened metal wear rings can be pried out of case.

4. Press the new back wear ring (7X) into the interstage case (111).
5. Place impeller (2X) on an arbor and mount between centers in a lathe or a grinder. Indicate front outside impeller hub to within 0.002 TIR maximum to be sure the arbor and impeller are running square.
6. Turn the back outside wear ring surface of the impeller (2X) until a 63 RMS or better finish is obtained.
7. Measure the outside diameter of the back impeller wearing surface and record this value. See measurement instructions in Section XI, Paragraph D.
8. Mount the interstage case (111) with new back wear ring (7X) installed in a lathe. Indicate female rabbet to within 0.002 TIR maximum.

NOTE

When replacing back wear ring with the standard front wear ring, (part number beginning with "00") machining in step 9 is not required. When replacing back wear ring with the undersize back wear ring (part number beginning with "US") machining in step 9 is required.

9. If replacing with an undersized back wear ring, bore wear ring (7X) to within the specified tolerance listed in Table 18 over the recorded size of the outside diameter of the back impeller wearing surface.
10. Reassemble pump. Refer to Section XI, Paragraph F, steps 18 through 65.

- H. **MOTOR.** The motor should be maintained in accordance with the manufacturer's instructions.
- I. **CHECK VALVE.** If applicable, the check valve should be maintained in accordance with the manufacturer's instructions.

XII. PARTS LISTS AND DRAWINGS.

This section contains listings of parts and corresponding drawings. Table 19 notes the recommended spare parts for this pumping unit. Refer to Figures 13, 14, and 15, for the location of parts identified by item numbers.

Table 19. Recommended Spare Parts List

Item Number	Description	Item Number	Description
2A	Impeller, First Stage	58	Interstage Sleeve
2X	Impeller, Per Stage	63	Bushing, Diffuser
6	Shaft	*63X	Bushing, Last Stage Diffuser
7A	Wear Ring, First Stage	*63Y	Sleeve Bearing
7B	Wear Ring, Interstage Case	69	Bearing Lockwasher
7X	Wear Ring, Diffuser	73	Gasket, Bearing Cap/Cooler
14A	Sleeve	73G	Gasket, Interstage Sleeve
14D	Spacer Sleeve, Suction and/or Discharge End	89A	O-ring, Bushing
*14E	Spacer Sleeve, Suction and/or Discharge End	89D	O-ring, Case
*14G	Spacer Sleeve, Suction End	*89F	O-ring, Bearing Cap
14X	Sleeve	*89H	O-ring, Bearing Gland
16	Ball Bearing, Inboard (Suction)	*89J	O-ring, Plugs/Fittings
17A	Gland, Inboard (Suction)	*89K	O-ring, Gauge Plug/Bushing
*17X	Gland, Outboard (Discharge)	*89M	O-ring, Plug
*18	Ball Bearing, Outboard (Discharge)	89W	O-ring, Bearing Cap Bolt
22	Bearing Jam Nut	89X	O-ring, Sleeve
28	Shaft Washer	89Y	O-ring, Plugs and Fittings
32A	Key, Impeller	90	Mechanical Seal, Inboard
32X	Key, Sleeve	*91	Mechanical Seal, Outboard
40	Slinger, Inboard (Suction)	168	Bearing Isolator, Inboard Bearing Cap
*40X	Slinger, Outboard (Discharge)	169	Bearing Isolator, Bearing Frame
46	Coupling Key - Pump	176	Snap Ring

*Parts are options that vary by pumping unit and bearing frame size.

This page intentionally left blank.

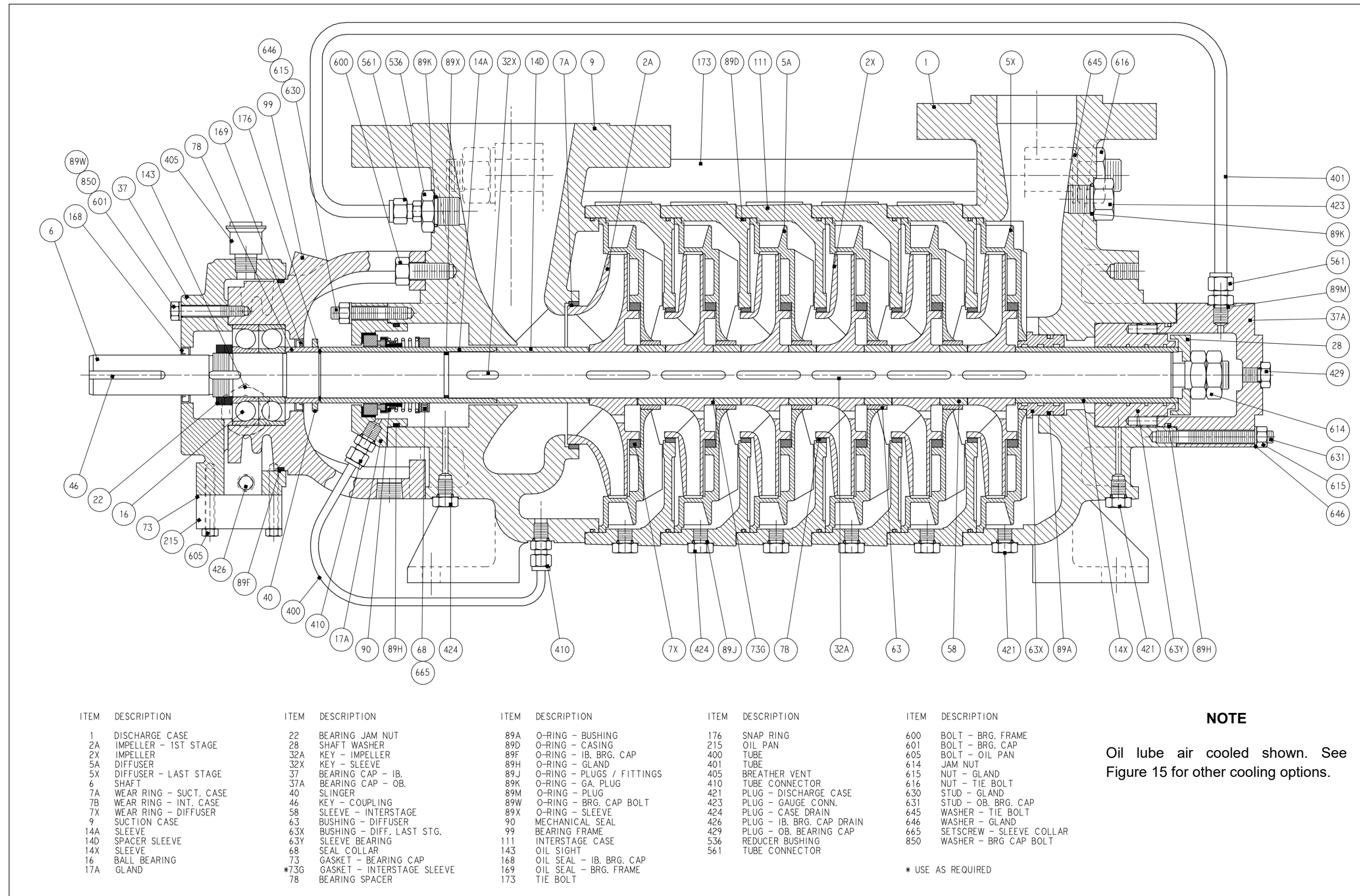

Figure 13. Sectional Assembly – Standard Sleeve Bearing
49/(50 blank)

This page intentionally left blank.

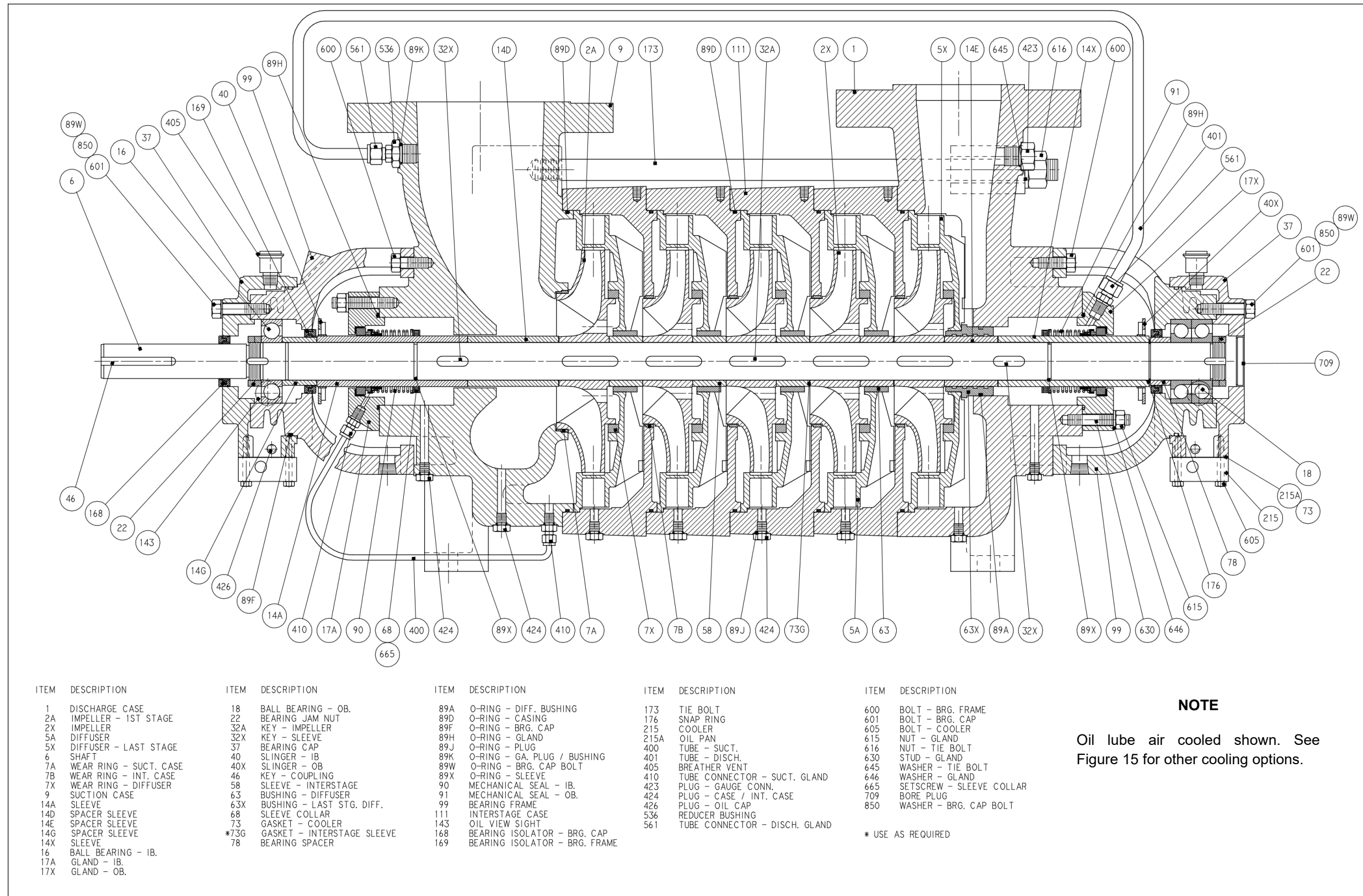

Figure 14. Sectional Assembly – Optional Mechanical Seals
51/(52 blank)

This page intentionally left blank.

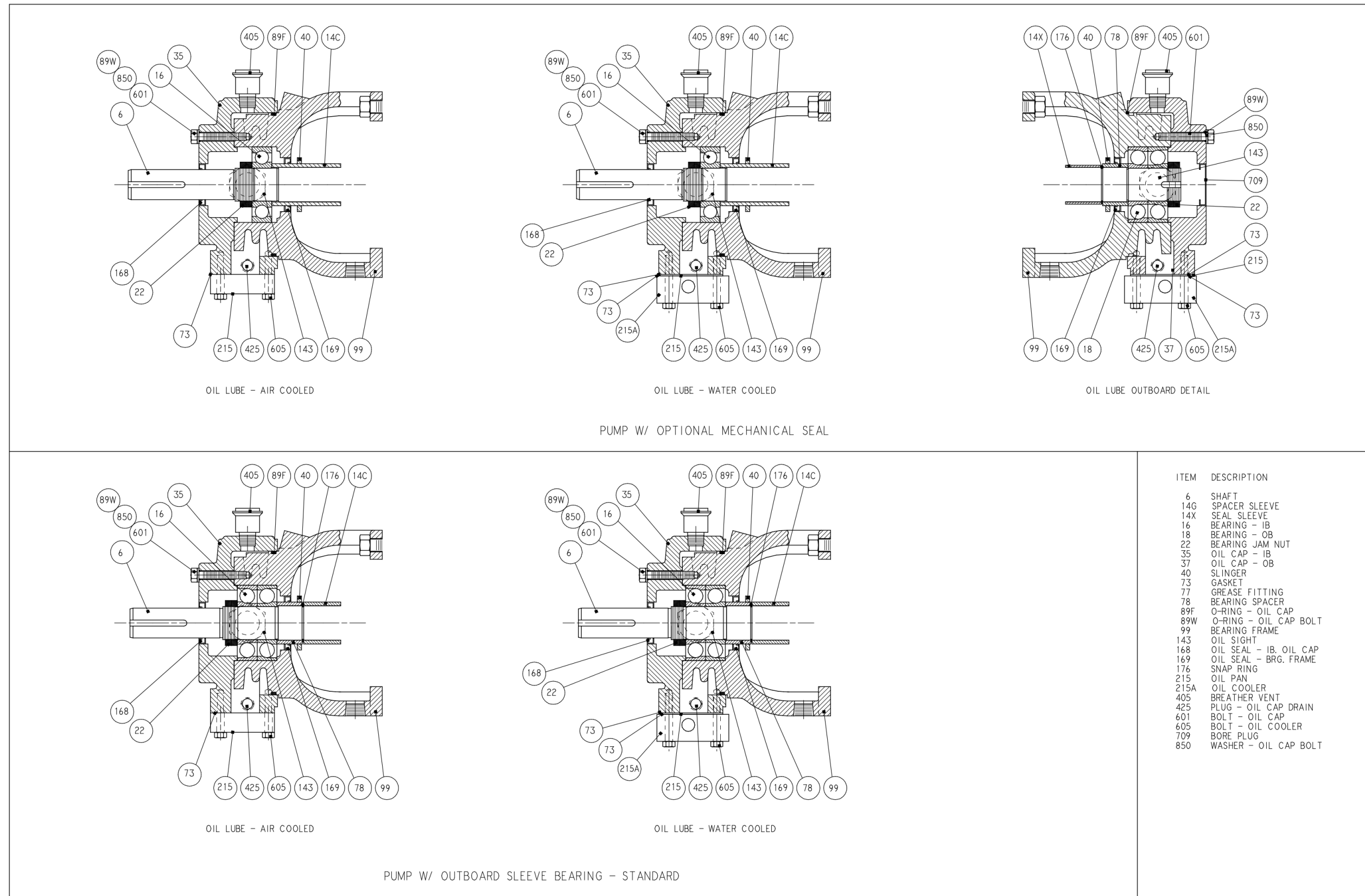

Figure 15. Cooling Options
53/(54 blank)

This page intentionally left blank.

This page intentionally left blank.



CARVERPUMP™

Built for purpose

2415 Park Avenue, Muscatine, IA 52761
Phone: 563.263.3410 www.carverpump.com

RS IOM
208 – 16.10.EN
For Units Built After December 2015