



I-120
120 – 16.05.EN

GH Pump

SAFETY, INSTALLATION, OPERATION AND MAINTENANCE INSTRUCTIONS

Part Number: _____

Serial Numbers: _____

 **These operating instructions contain fundamental information and precautionary notes. Please read the manual thoroughly prior to installation of unit, electrical connection and commissioning. It is imperative to comply with all other operating instructions referring to components of individual units.**

 **This manual shall always be kept close to the unit's location of operation or directly on the pump set.**

	<h2>EC Declaration of Conformity</h2>	
--	---------------------------------------	--

MANUFACTURER: CARVER PUMP COMPANY
2415 PARK AVE.
MUSCATINE, IOWA, USA 52761

PRODUCT DESCRIPTION: 120 GH Pumps

PART NUMBER:

www.carverpump.com
Phone: 1-563-263-3410

SERIAL NUMBER:

Email: sales@carverpump.com

DATE MANUFACTURED:

APPLICABLE EUROPEAN DIRECTIVES:

Machinery: The designated product complies with the following basic requirements of Directive 2006/42/EC:
Appendix I, section 1.1.2, 1.1.3., 1.1.5., 1.3.1., 1.3.2., 1.3.3., 1.3.4., 1.3.7., 1.3.8., 1.4.1., 1.4.2.1., 1.5.1., 1.5.8.,
1.5.9., 1.5.13., 1.6.1., 1.6.4., 1.6.5., 1.7.

APPLICABLE HARMONIZED STANDARDS:

Machinery: EN ISO 12100:2010 EN ISO 13732-1:2008
EN 626-1:2008 EN ISO 13857:2008

Declaration of Incorporation of Partly Completed Machinery (valid for 120 pumps supplied **without** a motor)

The product described in this Declaration of Conformity complies with the Applicable European Directives, EHSRs and relevant sections of the Applicable International Standards "**as a Component**". The incorporation of this pump with Electric Motors that are marked to confirm that they comply with the Low Voltage Directive 2006/95/EC and all the necessary guards, must be declared in conformity by the assembler.

Declaration of Conformity of Completed Machinery (valid for 120 pumps supplied complete **with** a motor)

The product described in this Declaration of Conformity complies with the Applicable European Directives, EHSRs and relevant sections of the Applicable International Standards. Motors for CE marked pumps will have motors that are marked to confirm that they comply with the Low Voltage Directive 2006/95/EC.

The special technical documentation has been compiled according to Annex VII Part B of Directive 2006/42/EC, and will be made available in electronic form to the authorities of the individual states upon justified request.

NOTE: The 120 pumps are NOT supplied or declared to ATEX Directive 94/9/EC.

Person authorized to compile the technical documentation:

Nicholas McMillan, Quality Manager, Carver Pump Company, 2415 Park Ave, Muscatine Iowa, USA 52761

Authorized Signature:

Date:

Nicholas McMillan
Quality Manager



Important safety information is contained in the installation, operation and service manuals; read and understand this information prior to installing or using this equipment

This Document applies only to the equipment described above and is invalid if not reproduced in its entirety.

SERVICE RECORD PAGE

Service No. _____ Model _____ Size and Type _____

Customer Order No. _____ Date Installed _____

Installation Date	Location	Application

PUMP RATING

Capacity _____ Total Head _____

Suction Pressure _____ Speed (RPM) _____

Liquid pumped _____ Temperature _____

Specific Gravity _____ Viscosity _____

Service _____

PUMP MATERIALS

Casing _____ Impeller _____ Shaft _____

Gaskets _____ Bearing Frame _____

Mechanical Seal/Packing _____

MOTOR DATA

Motor _____ Make _____ Serial No. _____

Type _____ Frame _____ AC or DC _____

HP _____ RPM _____ Volts _____

Phase _____ Cycles _____

NOTES ON INSPECTION AND REPAIRS

INSPECTION DATE	REPAIR TIME	REPAIRS	COST	REMARKS

INSTALLATION, OPERATION AND MAINTENANCE INSTRUCTIONS

TABLE OF CONTENTS

SECTION/PARAGRAPH	PAGE	SECTION/PARAGRAPH	PAGE
I. GENERAL DESCRIPTION	1	D. Leveling of Unit	10
A. General Information	1	E. Grouting	10
B. Machinery Directive 2006/42/EC	1	F. Coupling Alignment	11
C. Disclaimer	1	G. Pre-Installation Procedures	12
D. Personnel Qualification and Training	1	H. Piping	12
E. Pump Identification	2	I. Auxiliary Piping Connections and Gauges	12
F. Parts Inventory Guide	2	J. Motor	12
G. Parts Ordering	2	K. Direction of Rotation	12
H. Unauthorized Modification and Manufacture of Spare Parts	2	VIII. OPERATION	13
I. Unauthorized Modes of Operation	2	A. Pre-Start Cautions	13
II. SAFETY	2	B. Priming	13
A. Safety Precautions	2	C. Starting the Pump	13
B. Summary of Safety Marking	2	D. Operating Checks	14
C. Scope of Compliance	3	E. Stopping the Pump	14
D. Safety Awareness	3	F. Indefinite Shutdown	14
E. Safety Instructions for the Operator/User ..	3	IX. TROUBLESHOOTING OPERATING PROBLEMS	14
F. Safety Instructions for Maintenance Inspection and Installation Work	3	X. MAINTENANCE	17
G. General Safety Instructions	3	A. Lubrication of Pump Bearings	17
H. Non-Compliance with Safety Instructions ..	4	B. Lubrication of Motor Bearings	18
III. EQUIPMENT DESCRIPTION	4	C. Torque Values	18
IV. EFFECTS OF FLUIDS	5	XI. SERVICE AND REPAIR	19
A. Net Positive Suction Head (NPSH)	5	A. Preparations for Disassembly of Pump	19
B. Changing Pump Speed	5	B. Disassembly of Pump	20
C. Effects of Viscosity	5	C. Parts Inspection	21
D. Effects of Specific Gravity	5	D. Reassembly of Pump	24
V. TECHNICAL DATA	5	E. Replacement of Packing	26
VI. INSPECTION AND STORAGE	8	F. Replacement of Mechanical Seal	27
A. Inspection	8	G. Replacement of Optional Wear Ring on Pump Equipped with Enclosed Impeller	28
B. Packing for Return	8	H. Motor	28
C. Storage of Pump	8	I. Check Valve	28
VII. INSTALLATION	9	XII. PARTS LISTS AND DRAWINGS	28
A. Location	9		
B. Handling	9		
C. Foundation	9		

TABLE OF CONTENTS - Continued

LIST OF TABLES			LIST OF ILLUSTRATIONS		
NUMBER	TITLE	PAGE	NUMBER	TITLE	PAGE
1.	Maximum Discharge Pressure on Discharge Case	4	1.	Stuffing Box Dimensions.....	6
2.	Key Component Materials	7	2.	Transport of the Bare Pump	9
3.	Key Mechanical Data	7	3.	Transport of Close-Coupled Pump	9
4.	Pumping Unit Troubleshooting	15	4.	Grout and Foundation Bolting.....	10
5.	Recommended Torque Values	18	5.	Coupling Alignment.....	11
6.	Recommended Equipment	18	6.	Removing Packing with Hook.....	26
7.	Enclosed Impeller Clearances	23	7.	Packing Alignment	26
8.	Impeller/Wear Ring Matching Materials.....	28	8.	Mechanical Seal	27
9.	Parts List.....	29	9.	Exploded View – Frame Mounted (Shown with Mechanical Seal)	30
10.	Recommended Spare Parts	29	10.	Exploded View - Close-Coupled (Shown with Packing)	31

I. GENERAL DESCRIPTION AND SAFETY PRECAUTIONS.

A. GENERAL INFORMATION. Carver Pump Company products are carefully engineered and manufactured and, if properly installed, maintained, and operated, should provide maintenance-free operation and a long service life.



CAUTION

These instructions must always be kept close to the product's operating location or directly with the product.

This manual is designed to provide sufficient material to properly maintain the total pumping unit. The information presented should improve your knowledge and understanding of the GH Pump, thus upgrading the reliability, service life, and quality of pump maintenance.

These operating instructions are intended to facilitate familiarization with the product. These operating instructions do not take into account local regulations; the operator must ensure that such regulations are strictly observed by all, including the personnel called in for installation. Compliance with such laws relating to the proper installation and safe operation of the pumping equipment is the responsibility of the equipment owner and all necessary steps should be taken by the owner to assure compliance with such laws before operating the equipment. These instructions are intended to facilitate familiarization with the product and its permitted use to help satisfy safety requirements. Always coordinate repair activity with operations personnel and follow all plant safety requirements and applicable safety and health laws/regulations.

Refer to the sectional assembly specific to your unit for the location of parts identified by item numbers or description, Appendix A. Parts identified in Figures are representative of location and description. Variations do exist between configurations, not all parts described in the text may be on your configuration.



CAUTION

These instructions should be read prior to installing, operating, using and maintaining the equipment in any region worldwide and in conjunction with the main user instructions provided. The equipment must not be put into service until all the conditions relating to safety instructions have been met.

B. MACHINERY DIRECTIVE 2006/42/EC. This product is designed to Conform with Machinery Directive 2006/42/EC, Safety of Machinery EN ISO 12100:2010, EN ISO 13732-1:2008, EN 626-1:2008, EN ISO 13857:2008, and the EHSRs.

Complete Machinery for use in EU and EAA will have CE mark and Declaration of Conformity. Motors for CE marked pumps will have motors that are marked to confirm that they comply with the Low Voltage Directive 2006/95/EC.



CAUTION

Pumps assembled without a motor will have a Declaration of Incorporation and will not have a CE mark. When a motor is added, all guards must be installed, the motor must be CE marked and the completed machine reviewed for compliance for applicable EHSRs before a CE mark is attached.

NOTE

Since 29 December 2009 Directive 2006/42/EC has regulated the placing on the market, and the putting into service, of machinery in the EEA, replacing Directive 98/37/EC.

C. DISCLAIMER. Information in these User Instructions is believed to be reliable. In spite of all the efforts of Carver Pump Company to provide sound and all necessary information the content of this manual may appear insufficient and is not guaranteed by Carver Pump Company as to its completeness or accuracy.

D. PERSONNEL QUALIFICATION AND TRAINING. All personnel involved in the operation, installation, inspection and maintenance of the unit must be qualified to carry out the work involved. If the personnel in question do not already possess the necessary knowledge and skill, appropriate training and instruction must be provided. If required, the operator may commission the manufacturer/supplier to provide applicable training.

Follow instructions in this manual carefully. Factory warranty applies only when pump operates under conditions as specified on order acknowledgment, and if pump is properly installed and maintained as recommended herein. A copy of this manual should be available to operating personnel. Additional copies of this manual are available upon request from Carver Pump Company, your local distributor or from our web site. For comments and/or questions about information

provided, please contact Carver Pump Company or your local distributor.

E. PUMP IDENTIFICATION. The type of pump, pump size, operating data, and serial number are all stamped on the nameplate attached to the pump. Pump specifications should be recorded upon receipt of the pumping unit. Record all necessary information on the pump service record page and inspection and repair record provided at the front of this manual. This information must be included in all correspondence regarding the unit. This will ensure that the correct pump and/or parts are ordered in a timely manner.

F. PARTS INVENTORY GUIDE. To avoid unnecessary delays for maintenance, spare parts should be readily available, purchased before and kept in stock, for normal service. Most conditions will be covered if this manual is followed. For every one to three pumps, stock one spare set consisting of items listed in Table 8, Recommended Spare Parts. Part numbers correspond to Figures 9 and 10.

G. PARTS ORDERING. When ordering replacement parts, please specify:

- Model of pump (located on nameplate)
- Serial number of pump (located on nameplate)
- Part name (located on parts list)
- Quantity of parts needed

Carver Pump Company may ship an interchangeable part that is not identical in appearance or symbol. This is done only if the part has been improved. Examine parts carefully upon delivery before questioning factory or company representative. Never return parts to the factory without authorization from Carver Pump Company.

If an impeller is ordered, specify diameter across blade tips. Be sure diameter was NOT trimmed further than diameter shown on Carver Pump Company records.

If a driver or driver parts are ordered, specify name of manufacturer and all other data found on the driver nameplate.

H. UNAUTHORIZED MODIFICATION AND MANUFACTURE OF SPARE PARTS. Modifications or alterations of the pumping unit supplied are only permitted after consultation with Carver Pump and to the extent permitted by Carver Pump. Original spare parts and accessories authorized by Carver Pump ensure safety. The use of other parts can invalidate any liability

of Carver Pump for consequential damage and/or warranty.

I. UNAUTHORIZED MODES OF OPERATION. The warranty relating to operating reliability and safety of the unit supplied is only valid if the pumping unit is used in accordance with its designated use as described in the following sections. The limits stated on the nameplate must not be exceeded under any circumstances.

II. SAFETY.

A. SAFETY PRECAUTIONS. The manual is designed to provide adequate instructions for the safe and efficient installation, operation, or maintenance of the pump. Failure or neglect to properly install, operate, or maintain the pump may result in personal injury, property damage, or unnecessary damage to the pump. This manual must be read and understood both by the installation personnel and the responsible trained personnel/operators prior to installation and operation, and it must always be kept close to the location of the pumping unit for easy access.

B. SUMMARY OF SAFETY MARKING. The safety instructions contained in this manual where non-observance of the instructions will cause a hazard is specially marked with the symbol:



General hazard sign to ISO 7000 - 0434.

Notes highlight an operating or maintenance procedure, condition, or statement which is essential, but is not of known hazardous nature as indicated by DANGERS, WARNINGS and CAUTIONS.

The word "CAUTION" is used to introduce safety instructions whose non-observance may lead to damage to the machine and its functions.

The word "WARNING" is used to introduce safety instructions whose non-observance may lead to a potential hazard exist, capable of producing injury to personnel, if approved procedures are not followed.

The word "DANGER" indicates a location, equipment, or system where imminent hazards exist, capable of producing immediate injury or death to personnel, if approved procedures are not followed.

Instructions attached directly to the machine, e.g.

- Arrow indicating the direction of rotation
- Markings for fluid connections must always be complied with and be kept in a perfectly legible condition at all times.

Observe all notes, caution or danger tags attached to the equipment or included in this manual.

C. SCOPE OF COMPLIANCE.

Where Carver Pump has supplied only the bare shaft pump, the rating applies only to the pump. The party responsible for assembling the pump set shall select the coupling, driver, seal and any additional equipment, with the necessary EC Certificate/Declaration of Conformity establishing it is suitable for the area in which it is to be installed.

D. SAFETY AWARENESS. It is imperative to comply with the safety instructions contained in this manual, the relevant national and international explosion protection regulations, health and safety regulations and the operator's own internal work, operation and safety regulations.

E. SAFETY INSTRUCTIONS FOR THE OPERATOR /USER.

- Any hot or cold components that could pose a hazard must be equipped with a guard by the operator.
- Guards which are fitted to prevent accidental contact with moving parts (e.g. coupling) must not be removed whilst the unit is operating.
- Leakages (e.g. at the shaft seal) of hazardous fluids (e.g. explosive, toxic, hot) must be contained so as to avoid any danger to persons or the environment. Pertinent legal provisions must be adhered to.
- Electrical hazards must be eliminated. (In this respect refer to the relevant safety regulations applicable to different countries and/or the local energy supply companies.)

F. SAFETY INSTRUCTIONS FOR MAINTENANCE, INSPECTION AND INSTALLATION WORK. The operator is responsible for ensuring that all maintenance, inspection and installation work be performed by authorized, qualified personnel who are thoroughly familiar with the manual and pumping unit.

The pumping unit must have cooled down to ambient temperature, pump pressure must have been released and the pump must have been drained before working on any pumping unit. Work on the pumping unit must be carried out during shutdown. The shutdown procedure described in the manual for taking the unit out of service must be adhered to.

Pumps handling fluids that are hazardous to personnel must be decontaminated prior to being worked on.

Immediately following completion of the work, all safety relevant and protective devices must be reinstalled and/or reactivated. Please observe all instructions set out in the Section VIII on start up before returning the pumping unit to service.

G. GENERAL SAFETY INSTRUCTIONS.

- Various federal, state, and local laws affect installation, use, and operation of pumping equipment. Compliance with such laws relating to proper installation and safe operation of pumping equipment is the responsibility of the equipment owner.
- Prior to working on pump or driver, ensure all switches and circuit breakers have been locked in the open (off) position and tagged, "Out of Service."
- All circuits NOT known to be dead must be considered live at all times.
- DO NOT wear loose or torn clothing around rotating machines.
- While working near electricity, DO NOT use metal rules, flashlights, metallic pencils, or any other objects having exposed conducting material.
- Make sure you are NOT grounded while adjusting electrical equipment or using measuring equipment.
- In general, use only one hand when servicing live electrical equipment.
- Make sure to de-energize all electrical equipment before connecting or disconnecting meters or test leads.
- For connecting a meter to terminals for measurement, use a range higher than the expected voltage.
- Check to make sure that the frame of the driver and starter panel are securely grounded before operating pumping unit or performing any tests or measurements.
- If a test meter must be held or adjusted while voltage is applied, ground case of meter before starting measurement. DO NOT touch live equipment while holding the meter. Some moving vane-type meters should not be grounded nor held during measurements.
- DO NOT use test equipment known to be damaged or in poor condition.

H. NON-COMPLIANCE WITH SAFETY INSTRUCTIONS.

Non-compliance with safety instructions may result in personal injury, property damage, or unnecessary damage to the pumping unit. Non-compliance with these safety instructions will also lead to forfeiture of any and all rights to claims for damages. Non-compliance, can for example, result in:

- Failure of important pumping unit functions.
- Failure of prescribed maintenance and servicing practices.
- Hazard to personnel by electrical, mechanical, and chemical effects.
- Hazard to the environment due to leakage of hazardous substances.

Avoid Possible Non-Compliance. The following specific safety precautions apply to the pumping unit:

- DO NOT exceed maximum discharge pressure on discharge case (Refer to Table 1).
- DO NOT operate pump without fluid to seal or packing.
- DO NOT run pump dry for extended periods of time.
- DO NOT run pump against a closed discharge valve.
- DO NOT exceed the Maximum rated speed (3550 RPM).
- A check valve should be installed in the discharge line.
- Pumps assembled by Carver without a motor will have a Declaration of Incorporation and will not have a CE mark. When a motor is added, all guards must be installed, the motor must be CE marked and the completed machine reviewed for compliance for applicable EHSRs before a CE mark is attached.

Table 1. Maximum Discharge Pressure on Discharge Case

Pump Size	Maximum Working Pressure (PSI) Cast Iron Class 30
AA - 1 ¼ x 1 x 5	200
AB - 2 x 1 ½ x 5	200
AC - 2 ½ x 2 x 5	200
BA - 1 ¼ x 1 x 7	200
BB - 1 ½ x 1 ¼ x 7	200
BC - 2 ½ x 2 x 7	200
BD - 3 x 2 ½ x 7	200
BE - 4 x 3 x 7	200
BF - 5 x 4 x 7	200
CA - 1 ½ x 1 ¼ x 10	250
CB - 2 x 1 ½ x 10	250
CC - 2 ½ x 2 x 10	250
CD - 3 x 2 ½ x 10	250
CE - 4 x 3 x 10	250
CF - 5 x 4 x 10	250
CG - 6 x 5 x 10	250
DA - 2 x 1 x 11	250
DB - 4 x 2 x 11A	250
DC - 4 x 3 x 11	250
DD - 5 x 4 x 11	125
DE - 8 x 6 x 11	125
DF - 4 x 2 x 11B	250
EA - 2 ½ x 1 ½ x 13	150
EB - 2 ½ x 2 x 13	150
EC - 3 x 2 ½ x 13	150
ED - 4 x 3 x 13	150
EE - 5 x 4 x 13	150
EF - 6 x 5 x 13	150
EG - 8 x 6 x 13	150

III. EQUIPMENT DESCRIPTION.

Standard materials of construction are cast iron and CD4MCu. Other metallurgies are available, such as hard iron, monel, hastelloy, etc. Also available is a fully rubber lined version for abrasive and extremely corrosive application including the Flue Gas Desulfurization (FGD) process with high chlorides.

The bare pump consists of following major parts and options. Please refer to Figures 9 and 10, assembly drawings, for the location of parts identified by item numbers.

Item 1 - Casing. The casing houses the impeller (2 or 3) and consists of the discharge, suction cover (9), back cover (11), and stuffing box. The casing is secured to the suction cover with bolts (800) and to the discharge piping with bolts and nuts not provided with the unit.

Item 2 or 3 - Impeller. The pumps are equipped with semi-open (3) or enclosed (2) impellers. The impeller is

keyed to the shaft (6) by the impeller key (32) and is locked in place by the impeller capscrew (26) and impeller screw washer (28).

Item 6 - Shaft. The shaft of the pump is designed to provide stabilization to the rotor system when pump operates away from the best efficiency point. A coupling connects the pump shaft to the driver shaft.

Item 16 and 18 – Radial and Thrust Ball Bearings. Deep groove Conrad type, C-3 internal fit ball bearing or C-3 internal fit ball bearing are housed in the bearing frame (19).

Item 19 - Bearing Frame. If equipped, the principal function of the bearing frame is to carry the loads from the liquid end of the pump to the base and to transport power from the motor to the impeller (2 or 3). The bearing frame has an outboard radial ball bearing (16) and an inboard thrust ball bearing (18).

Item 90 – Mechanical Seal. A mechanical seal may be supplied in place of a packed stuffing box when specified by the customer. Many variations of types and materials are available.

IV. EFFECTS OF FLUIDS.

A. NET POSITIVE SUCTION HEAD (NPSH). Any liquid, hot or cold, must be pushed into the impeller of the pump by some absolute pressure, such as the atmosphere or the vessel pressure from which the pump takes its action.

The head in feet of liquid necessary to maintain the required flow into the pump is called the Net Positive Suction Head (NPSH). This value is measured above the vapor pressure of the liquid at the pumping temperature.

NPSH is commonly expressed in two ways: the NPSH required by the pump, and shown on the pump curve, is the head needed to cover the losses in the pump suction and the energy required to enable the liquid to climb onboard the leading edge of the impeller vane. The NPSH available is that inherent in the system, taking into account friction losses in suction piping, valves, fittings, etc. In all cases, the NPSH available, measured above vapor pressure, must exceed the NPSH required in order to push the liquid into the pump.

B. CHANGING PUMP SPEED. Changing the speed of a centrifugal pump affects the capacity, total head, NPSH required and the brake horsepower. In general, the capacity will vary in a direct ratio with the speed, whereas the total head and NPSH required will vary as the ratio of the speed squared. The brake horsepower will vary as the ratio of the speed cubed.

C. EFFECTS OF VISCOSITY. The pump is designed to deliver rated capacity at rated head for a liquid with a particular viscosity. When pump is handling heavy viscous liquid, the viscosity of the liquid must allow it to be pumped easily. The liquid may have to be heated prior to starting the pump. When contemplating operation at some viscosity other than that for which the pump was originally designed, check with Carver Pump Company.

D. EFFECTS OF SPECIFIC GRAVITY. The capacity and total head in feet of liquid developed by a centrifugal pump are fixed for every point on the curve and are always the same for the same speed. Neither capacity nor total head will be affected by a change in the specific gravity of the liquid pumped. However, since the discharge pressure in Pounds per Square Inch (PSI) and the brake horsepower required driving the pump are functions of the specific gravity of the liquid, both will be affected in direct proportion by any change in specific gravity. Therefore, an increase in specific gravity will raise the discharge pressure and is dangerous as it might overload the pump's driver or exceed the pump casing allowable pressure.

V. TECHNICAL DATA.

Specifications and operating limits should be recorded on a Service Record Page; an example is located in the front matter of this manual. Record the necessary information upon receipt of the pumping unit.

Stuffing Box. The stuffing box, Figure 1, is where the packing or mechanical seal is located.

Materials of Construction. The listed material specifications in Table 2 are referenced for standard catalog options.

Mechanical Data. The Key Mechanical data in Table 3 lists the maximum allowable horsepower at the maximum allowable pump shaft speed (3600 RPM). Dimensions and diameters are reference and given in inches.

10P Bearing Frame

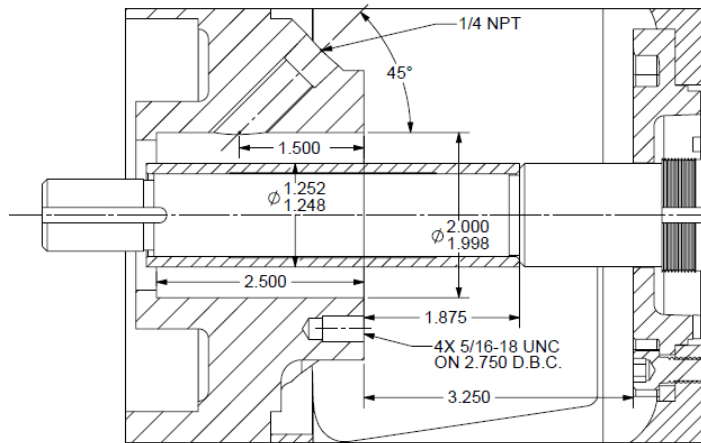

20P Bearing Frame

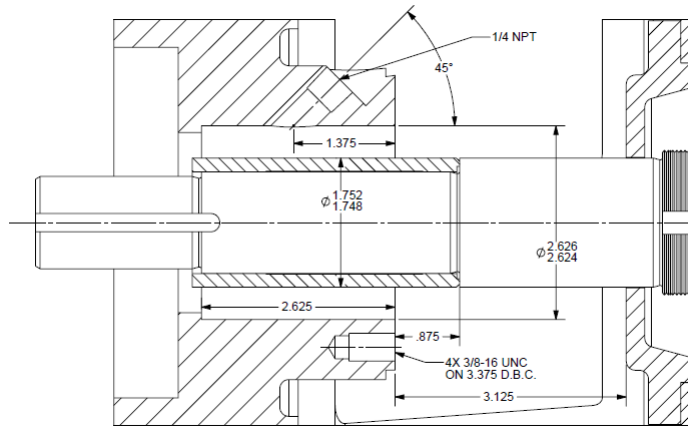

30P Bearing Frame

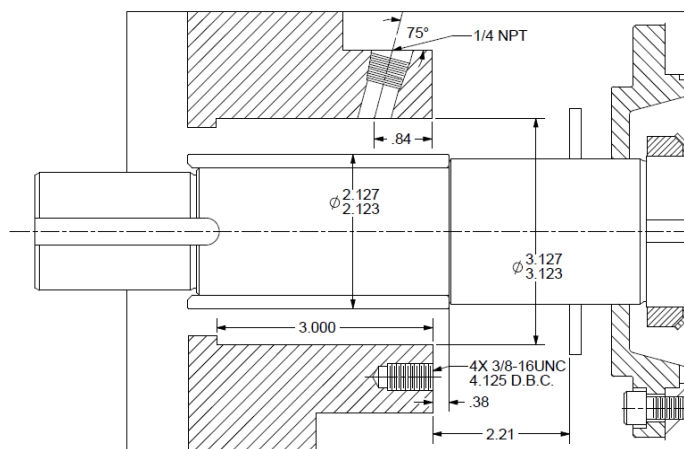

Figure 1. Stuffing Box Dimensions

Table 2. Key Component Materials

Component	Material	Specification
Bearing Frame	Cast Iron	ASTM A48, Class 30
Casing	316	ASTM A44, Class 30
	Cast Iron	ASTM A48, Class 30
Impeller	Bronze	ASTM B584, C87500
	Cast iron	ASTM A48, Class 30
	316 SS	ASTM A744, Grade CF-8M
Shaft	Carbon steel	ASTM A108, Grade 1215

Table 3. Key Mechanical Data

Item	Bearing Frame		
	10P	20P	30P
Max power (BHP) @ 1750 RPM	20	75	250
@ 3600 RPM	40	150	500
Radial bearing type	207	210	211
Thrust bearing type	307	310	5,611
Thrust bearing lube (standard)	Grease		
L10 bearing life (hrs) – radial	50,000		
- thrust	25,000		
Radial to thrust bearing c/l (in.)	6.75	8.50	11.20
Shaft diameter @ coupling	1.250	1.50	2.000
@ radial bearing	1.378	1.968	2.166
@ thrust bearing	1.378	1.968	2.165
@ impeller hub	0.875	1.250	1.625
@ shaft sleeve	1.000	1.375	1.750
Shaft sleeve OD (in.)	1.250	1.750	2.125
Impeller – thrust bearing c/l (in.)	8.00	9.00	9.63
Rotor WR2 (lb – in.) - shaft	0.014	0.058	0.126
7" impellers	15.10		
10" impellers	56.67		
11" impellers	137.56		
13" impellers	233.74		

VI. INSPECTION AND STORAGE.



A. INSPECTION. Upon receipt of the shipment, unpack and inspect the pumping unit and individual parts to ensure none are missing or damaged. Carefully inspect all boxes and packing material for loose parts before discarding them. Check to make sure the shipment complies with the purchase order. Immediately report any missing parts or damage incurred during shipment to the factory and to the Transportation Company and file your “damage and/or lost in shipment” claim with the carrier.

B. PACKING FOR RETURN. If the pumping unit is sent back to Carver Pump Company for repair, drain the unit, and re-seal all flanges and connections that were covered or plugged. Ship the pump(s) in an assembled condition to prevent damage to sealing faces of individual components. A Return Goods Authorization (RGA) and a material Safety Data Sheet (SDS) is required on all returned pumps. Copies of SDS records should be kept and maintained by the customer. The customer is responsible for cleaning and flushing the pump before it is returned to the factory. Make sure to specify the fluid used in the service.

C. STORAGE OF PUMP. If the equipment is not to be immediately installed and operated, store it in a clean, dry, well-ventilated place, free from vibrations, moisture and rapid or wide variations in temperature.

NOTE

Storage requirements vary depending on climatic environment, length of storage and equipment. For storage periods of three months or longer, contact manufacturer for specific instructions. Improper storage could damage equipment and would result in non-warranty covered restoration of non-warranty covered product failures.

When storing the pump up to three months rotate the shaft for several revolutions at least once per month to coat the bearings with lubricant, retard oxidation and corrosion, and prevent possible false brinelling.

The motor bearings should be prepared for storage according to the motor manufacturer’s instructions, in the motor manufacturer’s maintenance manual, which should come with the motor.

A pump which is made of iron or steel that sits in extreme heat, high humidity, or full or partially full water over 30 days will rust and will most likely seize. If the pump rusts and/or seizes, a complete overhaul and repair may be necessary to refurbish the pump.

Consider a unit to be in storage when:

1. It has been delivered to the job site and is waiting to be installed.
2. It has been installed but operation is delayed pending completion of construction.
3. There are long (30 days or more) periods between operating cycles.
4. The plant (or department) shut down for periods of longer than 30 days.

Measures to be taken for prolonged shutdown of installed pumping unit. If the pumping unit remains installed a periodic check of operation is in order to make sure that the pump is always ready for instant start-up and to prevent the formation of deposits within the pump and the pump intake area. Start up the pumping unit regularly once a month or once every 3 months for a short time (approximately 5 minutes) during prolonged shutdown periods. Prior to operation check run ensure that there is sufficient liquid available for operating the pump.

Interim Storage (Indoors)/Preservation. When the unit is temporarily put into storage, only the wetted low alloy must be preserved. Commercially available preservatives can be used for this purpose. Please observe the manufacturer’s instructions for application/removal.

The unit/pump should be stored in a dry room where the atmospheric humidity is as constant as possible. If stored outdoors, the unit and crates must be covered by waterproof material to avoid any contact with humidity. Protect all stored goods against humidity, dirt, vermin and unauthorized access!

All openings of the assembled unit components are closed and must only be opened when required during installation. All blank parts and surfaces of the pump are oiled or greased (silicone-free oil and grease) to protect them against corrosion.

VII. INSTALLATION.

A. LOCATION. The pump assembly should be located in an area that will permit periodic inspection and maintenance. Head room and access should be provided and all units should be installed in a dry location with adequate drainage. The discharge piping should be direct with as few elbows and fittings as possible.

The pump assembly should be installed as close to the fluid as possible. A short, direct suction pipe can be used to keep suction losses at a minimum. If possible, locate the pump so fluid will flow by gravity to the suction opening. The discharge piping should be direct with as few elbows and fittings as possible. The total NPSHA, which includes the suction lift and pipe friction losses, must be greater than the Net Positive Suction Head Required (NPSHR) by the pump.

B. HANDLING.



CAUTION

Use a hoist with adequate lifting capacity. See pump nameplate for weights.

Do not pick up the complete unit by the motor or the pump shafts or motor lifting eyes.

If the pumping unit slips out of the sling arrangement, it may cause injury to personnel and/or damage to the pumping unit.

Moving the unit requires proper preparation and handling. Always make sure that the pump or the pumping unit while being moved cannot slip out of the transport suspension arrangement. Use a sling for pumps without bases, refer to Figure 2. To lift a complete unit, a hoist or suitable lifting device should be attached to the base, refer to Figure 3. The individual motor may be lifted using proper eyebolts provided by the manufacturer, but these should not be used to lift the assembled unit.

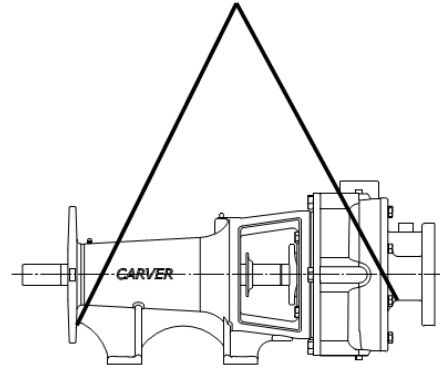

Figure 2. Transport of the Bare Pump

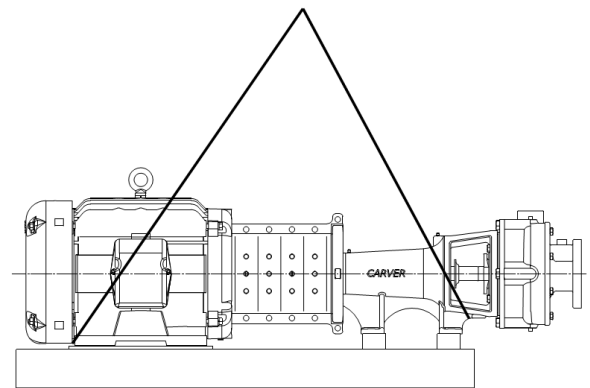

Figure 3. Transport of Coupled Pump

C. FOUNDATION. Make sure that the concrete foundation has set firmly before placing the unit on it. Its surface must be truly horizontal and even. The foundation bolts must be inserted in the baseplate holes. The foundation should be 3 to 6 inches wider and longer than the baseplate, have a level surface, and be of sufficient mass to prevent vibration and form permanent rigid support for the unit. The best foundations are concrete with anchor bolts of adequate size embedded in the foundation in pipe sleeves having an inside diameter 2-1/2 times larger than the bolt diameter. This will allow for accurate positioning of the unit. Keep the concrete surface clean, yet rough.

D. LEVELING OF UNIT. When the pump is supplied complete with motor and base, the unit is assembled at the factory. Lower unit onto foundation, positioning base structure so anchor bolts are aligned in middle of holes in base.

The base should be supported on either rectangular metal blocks with shims or on metal wedges having a small taper. The support pieces should be placed close to the foundation bolts. Refer to Figure 4, Grouting and Foundation Bolting. Place supports directly under the part of the base plate, which carries the greatest weight. Space the supports closely enough to provide uniform support of the base plate. Adjust the metal supports or wedges until the shaft is level. Check suction and discharge flanges of the pump by means of a level. Make corrections, as necessary, by adjusting the supports or wedges under the base plate.

The base should be supported on metal shims or metal wedges placed directly beneath the part of the base supporting the most weight. The shims or wedges should be spaced close enough to give support and stability.

Adjust metal supports or wedges until suction and discharge flanges are level.



CAUTION

Do not attempt to straighten the base by using the anchor bolts.

E. GROUTING. After the pumping unit has been leveled and the alignment is correct, grout the unit to the foundation using a high-grade, non-shrinking grout, refer to Figure 4. Proceed grouting using the following procedure:

Prepare concrete foundations, anchor bolts and leveling screws according to individual instructions covering these items.

1. Wax forms heavily with at least three coats of paste wax. Forms must be substantial and well braced. All corners, joints, bottoms must be sealed with silicone caulk for water tightness. All forms should have a 45° chamfer strip installed to prevent stress risers.
2. Anchor bolt-free length must be wrapped with duct seal or electricians' plastic tape to prevent grout from contacting the bare metal. Grout sticking to the anchor bolt will prevent the elongation necessary to develop the hold-down force. Failure to do this will result in broken anchor bolts.
3. If equipped leveling screws must be greased to permit removal prior to the final torque.
4. Do not use shim packs as a leveling device unless it is planned to remove them prior to final torque application.
5. Leveling screw pads should be a minimum of 1/2" thick with minimum diameter of 3". Corners of pad must be rounded to approximately 1/8" radius to prevent stress cracking. Set leveling screws on the chipped concrete surface. Set the pad with quick set cement or resin repair compound. With jacking bolt pads secure and level, set and level base with leveling screws. If not equipped with leveling screws use shims to level.
6. The underside of the standard factory steel base plate was painted with epoxy grout primer and should only require proper cleaning. If the base must be sandblasted, prepare the contact faces to SSPC-SP 6 Spec. If base cannot be set within 24 hours of blasting, the underside must be coated with a compatible rust inhibitive primer. Tighten foundation bolts loosely. **Allow the grout to fully cure before firmly tightening the foundation bolts.**

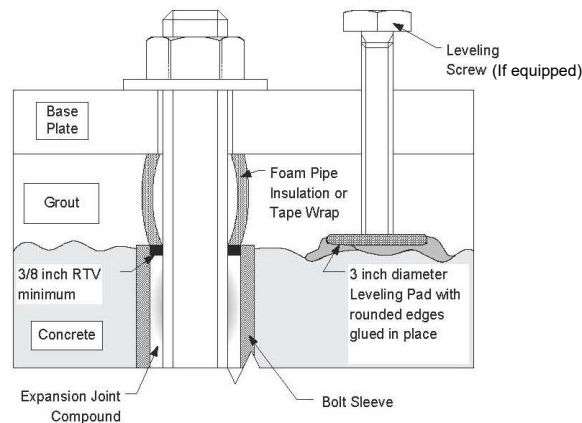

Figure 4. Grouting and Foundation Bolting

F. COUPLING ALIGNMENT. The pump and motor are connected by a coupling. Alignment is necessary when the pump or motor are removed from the base. The coupling should NOT be reconnected until the alignment has been completed. Always check the coupling alignment after shipping. The following is how to check the coupling alignment.

NOTE

Refer to coupling manufacturer’s manual for instructions regarding shaft alignment and recommended installation limits.

Soft Foot – The equipment must rest flat on its base. If one or more feet of the pump or motor are shorter, longer, or angled in some way to prevent uniform contact (a condition commonly known as “soft foot”) it must now be corrected.

To improve the life of the coupling, the shafts must be aligned to minimize deflection of the flexing elements. Shaft alignment is required in the axial, parallel, and angular directions, with each of these values not to exceed the recommended installation limits. Shaft alignment can be measured using various established methods, including Laser Alignment, Reverse Dial Indicator, and Rim and Face.

The motor and pump shafts must be accurately aligned as any misalignment can cause damage to the coupling, motor, or pump. When the shafts are in correct alignment, the coupling hubs will be on a common axis, concentric with each other, and at the correct distance apart. If the coupling hubs are misaligned, it is general practice to adjust the driver to the pump. Insert full

shims under the feet or supports of the motor and tighten fastening bolts until correct alignment is achieved.

1. Move the pump or motor to achieve acceptable alignment. When properly aligned, the disc packs will be centered and approximately parallel to their mating flange faces and the flexing elements will have little visible waviness when viewed from the side.

NOTE

Refer to the coupling manufacturer’s manual for recommended installation limits for Parallel, Angular, and Axial alignment.

2. The “Parallel Misalignment” value (P) is the offset between the centers of the hubs, as shown in Figure 5.
3. When the Parallel Offset is measured by rotating the hubs in unison with dial indicators as shown in Figure 5, the Total Indicator Reading (TIR) should be divided by (2) to calculate (P).
4. It should be noted that parallel offset measured on the hub surfaces includes misalignment of the equipment shafting plus any variation (TIR) in the hubs. This may be helpful to consider during problem solving for alignment difficulties.
5. The “Angular Misalignment” value is the maximum difference between the measurements X and Y taken at opposite ends of the hub flanges, as shown in Figure 5.

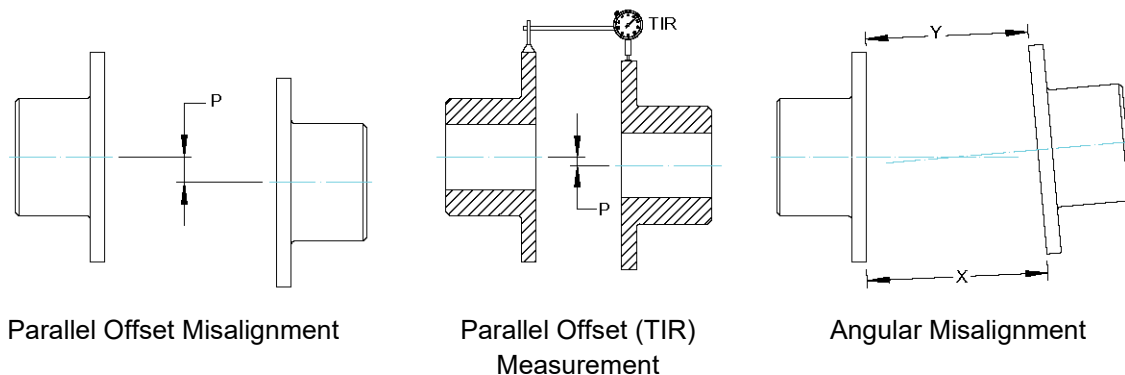

Figure 5. Coupling Alignment

G. PRE-INSTALLATION PROCEDURES.**DANGER**

Before activating the pumping unit, check to make sure there are no personnel working on the unit. Serious injury or death to personnel could result if the unit is activated while being worked on.

1. Observe all caution or danger tags attached to the equipment.

**CAUTION**

Never run the pump dry. Close running fits within the pump are liquid lubricated. Dry running will result in pump seizure or damage.

2. Before starting the pump, rotate shaft by hand to assure all moving parts are free from rubbing.
3. Before starting the pump, install guards to enclose all exposed rotating parts.
4. Before starting the pump, fill the volute and suction line with liquid. The pump is being primed in accordance with Section VIII, Paragraph B.
5. Before starting a mechanical seal pump equipped with external flush lines, turn on seal water, and confirm the seal water is at sufficient pressure.
6. Make sure all fasteners are torqued to the proper torque values to avoid equipment damage and injury to personnel.

H. PIPING. All piping should be independently supported near the pump so that pipe strain will not be transmitted to the pumping unit.

**CAUTION**

All piping connections must be made with the pipe in a freely supported state. Do not apply vertical or side pressure to align the piping with the pump flange.

Before connecting suction, discharge, and auxiliary piping, check to see that the piping is clean internally. Any debris in the piping will be drawn into the pump passageways and can cause extreme damage. The internal diameters of the suction and discharge lines must be equal to the internal diameters of the pump suction and discharge nozzles.

Suction lift lines shall be laid with a rising slope toward the pump and suction head lines with a downward slope towards the pump.

The suction pipe must be airtight and sloped upward to pump flange to avoid air pockets which will impair pump operation. The discharge pipe should be as direct as possible using a minimum number of valves to reduce pipe friction losses.

Never use a straight taper (concentric) reducer in a horizontal suction line because air pockets may form in the top of the reducer and the pipe. Use an offset (eccentric) reducer instead.

It is recommended to install a check valve and closing valve in discharge line and closing valve in suction line, depending on the type of plant and pump. The check valve, between the pump and valve, protects pump from water hammer and prevents reverse rotation in the event of power failure. Closing valves are used in priming, starting, and pump shut down. Pump must never be throttled by use of a valve in the suction line.

Thermal expansions of the pipeline must be compensated by appropriate measures so as not to impose any extra loads on the pump exceeding the permissible pipeline forces and moments. Refer to Table 1 for permissible forces and moments.

I. AUXILIARY PIPING CONNECTIONS AND GAUGES. In addition to primary piping connections, the pump may require other connections such as gauges or drains. All these lines and gauges should now be installed. Refer to vendor mechanical seal drawing for seal line connections to the mechanical seal.

J. MOTOR. Refer to motor vendor's manual for motor information and information on connecting to the power supply.

**DANGER**

Connection to the power supply must be affected by a trained electrician only. Check available main voltage against the data on the motor rating plate and select appropriate start-up method.

K. DIRECTION OF ROTATION. Correct pump rotation is indicated by an arrow on the bearing frame or back cover depending on the style of pump that you have. The standard direction of rotation, viewed from the motor end, is clockwise.

VIII. OPERATION.**A. PRE-START CAUTIONS.****DANGER**

Before activating the pumping unit, check to make sure there are no personnel working on the unit. Serious injury or death to personnel could result if the unit is activated while being worked on.

1. Before starting or operating the pump, read this entire manual, especially the following instructions.
2. Observe all caution, warning or danger tags attached to the equipment.
3. Rotate both the pump and driver shafts by hand to assure all moving parts are free.
4. Before starting the pump, install closed guards around all exposed rotating parts.
5. Check to make sure that fluid in the pump is free of debris.

**WARNING**

Never run the pump dry. Close running fits within the pump are liquid lubricated. Dry running will result in pump seizure or damage.

6. Before starting a mechanical seal pump equipped with external flush lines, turn on mechanical seal water, and confirm the mechanical seal water is at sufficient pressure. Running without fluid in the stuffing box may result in packing/mechanical seal failure.
7. If excessive vibration or noise occurs during operation, shut the pump down and rotate shaft by hand. If excessive vibration or noise continues, consult a Carver representative.

B. PRIMING. Dry running a centrifugal pump can result in extensive damage and possible seizing. It is, therefore, imperative that the pump be primed prior to initial start-up and that prime must be maintained through subsequent start-stop cycles.

The priming procedure is different for positive and negative suction head systems. Follow the procedure listed below.

Positive Suction Head:

1. Open the vent on the highest point on the pump volute.
2. Open all suction valves.
3. Allow liquid to flow from vent hole until all air bubbles are vented. Then close the vent.
4. The pump is now primed.

Negative Suction Head:

1. Install an ejector or vacuum pump on the vent at the highest point on the volute.
2. Close the discharge valve.
3. Open the suction valve.
4. Start the ejector or vacuum pump.
5. Allow liquid to flow until a continuous flow is exhausted from ejector. Then close the valve to the vent.
6. The pump is now primed.

C. STARTING THE PUMP.**CAUTION**

DO NOT operate pumping unit against a closed discharge system. If pump has any chance of seeing operation against a closed system, a bypass system allowing a minimum design flow should be installed. This bypass will be satisfactory for short periods of operation. For extended periods of operation, the bypass should be sized for the minimum continuous flow required by the pump.

1. Confirm pumping unit is ready to start. Complete Section VIII, Paragraphs A and B.
2. If unit is equipped with mechanical seal cooling lines, confirm that the mechanical seal cooling water is turned on.
3. Open discharge valves slightly, about 1 to 1 ½ turns if pump is being started for the first time or from being turned off for overhaul.
4. Open valves to pressure gauges in the system.
5. Start electrical power supply to driver. Start the pump.
6. Slowly open system valves in discharge line and adjust pressure and flow to the appropriate operating conditions. Refer to pump nameplate and system operating procedures for design point condition.

D. OPERATING CHECKS.

1. Check for undue vibration or noise. If any occurs and does not stop within a short period of time, turn off the pump. For determination of the cause and its remedy refer to Troubleshooting in Section IX or consult Carver Pump Company.
2. Check mechanical seals or packing rings for leakage.
3. Check for adequate lubricating liquid flow to the seal or packing.
4. Check that pump is operating within design criteria and perimeters. Check and record flow and pressure readings. The flow and pressure readings should be within the operating system guidelines and similar to number stamped on the pump nameplate.
5. Check and record bearing temperature. It should not exceed 70° C (160° F). Both inboard (018) and outboard (016) ball bearing temperatures should be measured and recorded at a minimum of 15-minute intervals until the ball bearing temperatures stabilize. Stabilization of ball bearing temperature can be defined as the results of three consecutive readings at approximately 15-minute intervals with no temperature rise.
6. Check and record power input to the motor.
7. Check and record vibration.

E. STOPPING THE PUMP.

When pump is handling hazardous fluid, extreme care must be taken to ensure safety of personnel when attempting to drain pump. Suitable protection devices should be used and/or protective clothing should be worn.

1. If the pump is stopped for overhaul, slowly close the discharge valve. Otherwise leave discharge valves set at condition.
2. Stop the pumping unit in accordance with the directions on the electrical power supply.
3. Tagout and lockout power to motor according to OSHA Standard 1910.147.
4. Close discharge and suction valves and any auxiliary fluid lines.
5. The pumping unit is now off.

F. INDEFINITE SHUTDOWN.

Stop the pumping unit per Section VIII, Paragraph E. Remove casing plug to drain casing. Drain all piping if there is a possibility of liquid freezing. Relubricate bearings. Provide pump and driver with a protective cover.

Measures to be taken for prolonged shutdown of installed pumping unit. If the pumping unit remains installed a periodic check of operation is in order to make sure that the pump is always ready for instant start-up and to prevent the formation of deposits within the pump and the pump intake area. Start up the pumping unit regularly once a month or once every 3 months for a short time (approximately 5 minutes) during prolonged shutdown periods. Prior to operation check run ensure that there is sufficient liquid available for operating the pump.

IX. TROUBLESHOOTING OPERATING PROBLEMS.

If you have followed the installation and starting procedures outlined in this manual, the pump should provide reliable service and long life. However, if operating problems do occur; significant time and expense can be saved if you refer to Table 3 to eliminate the most common causes of those problems.

NOTE

Immediate action to be taken before proceeding with corrective actions in Table 4 is to stop the pump, refer to Section VIII, Paragraph E.

Table 4. Pumping Unit Troubleshooting

SYMPTOM	IMMEDIATE ACTION	PROBABLE CAUSE	CORRECTIVE ACTION
Pump does not deliver rated capacity or rated head.	1. Stop the pump, refer to Section VIII, Paragraph E.	1. Excessive system pressure. 2. Speed too low, motor speed incorrect, or line voltage too low. 3. Valves are not fully open or plugged discharge line. 4. Clogged impeller. 5. Reverse rotation. 6. Motor running on two phases only. 7. Excessive wear of internal parts. 8. Liquid level in tank too low. 9. Vent in suction cover plugged.	1. Check GPM and head against design conditions; Consult local distributor or Carver Pump Company. 1. Correct motor speed. 2. Adjust belt tension. 3. Check electrical supply and correct as necessary. 1. Open valves and if necessary, lock valves open to prevent accidental closure. 2. Inspect and clean discharge. 1. Disassemble pump and clean impeller, if necessary. 1. Check power connections to motor. 1. Replace defective fuse. 2. Check electrical cable connections. 1. Disassemble pump, inspect and replace worn parts. 1. Increase liquid level in tank. 1. Clean vent.
Leakage at case joints.	1. Stop the pump, refer to Section VIII, Paragraph E.	1. Gaskets damaged.	1. Disassemble pump and replace gaskets.
Bearings run hot.	1. Stop the pump, refer to Section VIII, Paragraph E.	1. Bearing setting incorrect. 2. Worn bearings.	1. Correct bearing axial clearance. 1. Replace bearings.

Table 3. Pumping Unit Troubleshooting - Continued

SYMPTOM	IMMEDIATE ACTION	PROBABLE CAUSE	CORRECTIVE ACTION
Pump discharge pressure excessive.	1. Stop the pump, refer to Section VIII, Paragraph E.	<ol style="list-style-type: none"> 1. Excessive speed. 2. Pump is pumping fluid with specific gravity in excess of that specified. (If temperature of fluid is lower, then specified specific gravity will be higher.) 	<ol style="list-style-type: none"> 1. Check speed precisely. Decrease speed. 1. If prescribed fluid temperature or specific gravity cannot be attained, one or more of the following measures can be taken: <ol style="list-style-type: none"> a. Partially close discharge valve, reducing pump capacity to a point where driver is not overloaded. b. Install more powerful driver. Consult Carver Pump Company specifying exact operating conditions.
Pump overloads motor.	1. Stop the pump, refer to Section VIII, Paragraph E.	<ol style="list-style-type: none"> 1. Speed too high. 2. Pump discharge pressure is lower than design point, therefore pump's volume too high (check pump nameplate). 3. Same as 2 under "Pump Discharge Pressure Excessive." 	<ol style="list-style-type: none"> 1. Check pumps RPM and determine correct sheave and belts for proper speed. Consult local distributor or Carver Pump Company. 1. Partially close discharge valve until pressure at discharge flange is as specified. Decrease speed if driver remains overloaded. 1. Same as 2 under pump discharge pressure excessive.

X. MAINTENANCE.

Generally, the pump does not need continuous supervision. The pump should always run quietly and smoothly, without vibration. Regular checks of the pump running noises will prevent the risk of excessive temperatures as a result of bearings running hot or defective bearing seals. To ensure such operation, the following maintenance schedule should be applied at regular intervals during operation of the pump. Occasional visual checks are recommended. Data should be recorded periodically for each pump to keep track of maintenance which has been performed and to note operational problems. A sample maintenance record sheet is provided for this purpose at the front of this manual.

NOTE

Regular inspection and service are essential for safe operation of the pump. Any auxiliary systems installed must be monitored, if necessary, to make sure they function correctly.

Parts marked with * are options or vary by pump.

Daily Inspection:

- Visually inspect unit.
- Check bearing temperatures.
- Check for leakage at mechanical seal.

Weekly Inspection:

- Check power (amps) readings.
- Check pump discharge pressure.
- Check vibration on pump and driver bearings. Vibration should NOT exceed 1.5 of overall displacement (unfiltered) peak to peak mils (0.001") at 3600 RPM and 3.0 of overall displacement (unfiltered) peak to peak mils (0.001") at 1750 RPM.

Monthly Inspection:

- Check foundation bolts.

Semi-annual Inspection:

- Grease bearings. DO NOT OVER GREASE.
- If stand-by pumps are installed, it is advisable to operate pumps on a rotational system to give each pump a periodic duty. This ensures that stand-by pumps will have periodic operation and always be in good condition for instant start-up.

12,500 Hours - Overhaul

- For pump overhaul, complete Section XI, Service and Repair.

A. LUBRICATION OF PUMP BEARINGS.

Ball Bearing (16 and 18). The pump ball bearings (16 and 18) are grease lubricated.

Grease, lubrication frequency depends on operating conditions. Normal duty calls for lubrication after 1,000 hours and every 10,000 hours afterwards. Ball bearings is lubricated at Carver Pump Company with Amoco Rykon Premium Grease No. 2EP or equivalent, non-soap, polyurea thickened grease with a drop point of 450 degrees F. This grease was selected because of its suitability for extreme pressures and its high temperature stability. Never mix greases with differing properties.

Polyurea based greases are NOT compatible with lithium or soda soap based greases. Therefore, the type of grease added should not vary. However, if it is necessary to change grease types, the bearing cap (35) should be thoroughly cleaned and flushed with suitable solvent to remove all traces of old grease. Disassemble pump according to Section VII, Paragraph B, remove shaft and ball bearings (16 and 18) from bearing frame (19) and follow these procedures:

NOTE

It is recommended that when ball bearings are removed from the shaft, the ball bearing should be replaced. If the ball bearing is in good condition and must be reused, follow the procedures below.

1. Place ball bearing (16 and/or 18), bearing frame (19), and bearing cap (35) in a wire or mesh basket and suspend the basket in a light mineral solvent. Allow it to soak, preferably overnight.
2. After soaking and cleaning the ball bearing (16 and/or 18), bearing frame (19) and bearing cap (35) should be rinsed in a clean, light mineral solvent and agitated vigorously to remove all loosened hard grease and dirt.
3. Dip ball bearing (16 and/or 18) in clean, light oil and spin by hand to determine that all foreign matter has been removed.
4. After cleaning, repack ball bearing (16 and/or 18) half full on both sides with a good quality bearing grease.
5. Proceed with reassembly of pump according to Section VII, Paragraph E.

To lubricate ball bearing (16 and/or 18) use the following procedure:



CAUTION

Over greasing creates heat and is the cause of many problems requiring repair. DO NOT OVER GREASE.

1. Never lubricate ball bearing (16 and/or 18) while unit is running. If necessary, shut down pumping unit according to Section IV, Paragraph E.



CAUTION

Do not lubricate bearing with a power grease gun.

2. Using a hand-operated grease gun on grease fittings, add approximately one ounce of fresh grease. With most hand-operated grease guns, two or three pumps are enough. DO NOT OVER GREASE. When installing new bearing, pack new bearing only half full with grease. Bearing temperature may rise above normal immediately after lubrication but should stabilize within 4 to 8 hours.

B. LUBRICATION OF MOTOR BEARINGS. See motor manufacturer’s instructions to be sure motor ball bearings are properly lubricated.

C. TORQUE VALUES. Refer to Table 5, Recommended Torque Values. Clean and properly lubricate threads and bearing face of the fastener to obtain the proper fastener loading from these torque values. Fasteners should be tightened evenly and in stages. Refer to your torque wrench manual for the proper use of your wrench.

Table 5. Recommended Torque Values (ft-lbs)

Bolt Size	Material		
	Composite	Steel (or otherwise noted)	316 Stainless Steel
¼"-20	5	5	7
5/16"-18	11	11	12
3/8"-16	18	18	21
½"-13	33	39	45
5/8"-11	54	83	97
¾"-10	80	105	132
7/8"-9	109	160	203
1"-8	144	236	300

Table 6. Recommended Equipment

Tools	Materials	Test Equipment
Spanner Wrench Rawhide or Wood Mallet Wooden Wedge Allen Wrench Set Socket, Open, & Box Wrench Set Vice Grips Torque Wrench Bearing Heater	Grease, Polyurea base O-ring Lubricant Rust Solvent Dow 111 Lubricant	Belt Alignment Gauges Volt-Amp Meter Belt Tension Gauge

XI. SERVICE AND REPAIR.

Refer to Figures 9 and 10 to locate the pump parts by item number and parts list Table 8. If a specific sectional assembly drawing exists for a particular pumping unit, then that drawing should be referred to for service work.

A. PREPARATIONS FOR DISASSEMBLY OF PUMP.

During disassembly, match mark parts so they can be replaced in their original position. All parts should be thoroughly cleaned or replaced with new, if necessary. Sealing faces should be perfectly clean.



CAUTION

Factory authorized parts must be used to safely maintain your Carver Pump.

NOTE

To avoid damage to O-rings, check to make sure all parts are free of sharp edges or burrs.

All O-rings, ball bearings, shims, mechanical seals, lip seals, packing, and gaskets if disturbed from position should be replaced.

Variations do exist between configurations, not all parts described in the text may be on your configuration. Review what variations your pumping unit has before starting. Parts marked with * are options or vary by pump.

After prolonged operation, components may not be easily removed from shaft. In such instances, rust solvent may be used and suitable extracting tools applied wherever possible. DO NOT use force under any circumstances. Refer to Table 6, Recommended Equipment, for proper tooling during disassembly and assembly. Refer to appropriate sectional drawing for location of parts followed by an item number.

Prepare the pumping unit for disassembly using the following list:

1. Read this entire section and study the applicable sectional view drawing and parts list before disassembling the pump.
2. Stop the pumping unit; refer to Section VIII, Paragraph E.



DANGER

Before attempting to disassemble the pump, the electrical power supply to the driver must be locked and tagged in the "OFF" position to prevent injury or death to personnel servicing the pumping unit.

3. Remove terminal box cover. Disconnect motor (200) leads. Reconnect terminal box cover.
4. Remove splashguard (132) from bearing frame (*19) or adaptor (*71).

NOTE

Refer to cartridge seal (*89), refer to vendor instructions for proper mechanical seal removal procedure.

5. For cartridge mechanical seals (*90), reinstall seal clip.
6. Close suction and/or discharge valves. Shut off and close all valves controlling flow of liquid to and from pump. The pump should be cooled down to ambient temperature. The casing must be empty and not under pressure.



DANGER

When pump is handling hazardous fluid, extreme care must be taken to ensure safety of personnel when attempting to drain pump and piping before disconnecting the pumping unit. Suitable protection devices should be used and/or protective clothing should be worn. Applicable hazardous material procedures must be followed.

7. Drain casing (1) by removing casing plug (550) to remove any remaining fluid. If necessary, flush pump to remove corrosive or toxic pumpage. Collect and dispose of corrosive or toxic material appropriately. Reinstall plug in casing when fluid is completely drained.

**DANGER**

Be sure to adequately support the piping prior to disconnecting the pumping unit. Failure to adequately support the piping could result in serious injury or death to personnel and/or damage to the pumping unit.

8. Disconnect piping, gauge lines, and auxiliary connections, as necessary.

B. DISASSEMBLY OF PUMP. The instructions that follow are an aid for properly trained personnel to service your Carver Pump. Refer to Figures 9 and 10 to locate the pump parts by item number and parts list Table 9. If a specific sectional assembly drawing exists for a particular pumping unit, then that drawing should be referred to for service work. Read this entire section before disassembling the pump.

NOTE

Refer to Section II for Safety precautions before disassembling pump.

Variations do exist between configurations, not all parts described in the text may be on your configuration. Review what variations your pumping unit has before starting. Parts marked with * are options or vary by pump.

After completion of disassembly, all parts should be thoroughly cleaned or replaced by new ones if necessary. All gaskets and sealing faces should be perfectly clean. When cutting new gaskets, make sure they are exactly the same thickness as the old ones unless noted.

**CAUTION**

Use a hoist with adequate lifting capacity; refer to Section VII, Paragraph B, for lifting the complete unit.

When pump is handling hazardous fluid, extreme care must be taken to ensure safety of personnel when attempting to drain pump and piping before disconnecting the pumping unit. Suitable protection devices should be used and/or protective clothing should be worn. Applicable hazardous material procedures must be followed.

NOTE

Mark or number each component while dismantling according to sequence.

The individual components should be unscrewed or removed.

1. Complete Section XI, Paragraph A before continuing with disassembly.
2. Remove coupling guard (*131) and disconnect coupling (*42) from frame mounted pump.
3. Disconnect tubing and tube fittings, as necessary.

**CAUTION**

Use a hoist with adequate lifting capacity; refer to Section VII, Paragraph B, for lifting the complete unit.

4. Unbolt bearing frame (19) or motor (*200) from base and move pumping unit to open working area.
5. Remove splash guard (132) from adaptor (*71) if splash guard hasn't already been removed.

NOTE

Take special care during disassembly with the mechanical seal rotary and stationary elements when removing the casing off the shaft.

6. On frame-mounted pumps, remove bolts (*800B) from back cover (11) and casing (1). Remove rotary assembly from casing and take to a suitable work area.
7. On close-coupled pumps, remove bolt (*800B) from back cover (11) and casing (1). Remove

rotary assembly along with motor and take the items to a suitable work area.

8. Remove hex nuts (830) and flat washers (850) from studs (820). Slide gland (17) towards slinger (40) to release tension on mechanical seal (*90) or slide back and remove gland halves from packing rings (*13).
9. Remove impeller capscrew (24), impeller O-ring (700C), impeller washer (28), and impeller gasket (73C). The best tool to remove impeller capscrew is a hex wrench welded to a socket head.
10. Remove impeller (2 or 3) from shaft (*6). Remove impeller key (32A).
11. Remove bolt (*800C) from bearing frame (*19) and adaptor (*71). Remove back cover (11) from adaptor and from shaft (*6). Remove O-ring (700A) from back cover and discard.

NOTE

Refer to mechanical seal (*90) vendor instructions for proper mechanical seal removal procedure.

DO NOT remove rotating element of mechanical seal (*90) from shaft sleeve (*14), at this point, especially if mechanical seal is relatively clean and in good working condition.

12. On pumps equipped with mechanical seal (*90), remove seal spacer (*68), sleeve gasket (73A), and shaft sleeve (*14) with mechanical seal from shaft (*6). Inspect rotating element of mechanical seal before removing from shaft sleeve. If replacement is required remove rotating element of mechanical seal from shaft sleeve.
13. Remove old packing (*13), lantern ring (*29) and packing retaining ring (*63) from back cover (11).
14. Remove gland (17), and O-ring (700D) from shaft (*6).
15. Remove slinger (40) from shaft (*6). If the slinger is damaged and needs replaced or it is necessary to replace the ball bearings (*16 or *18).
16. Remove bolts (*800D) and adaptor (71) from motor (200).

NOTE

If gaskets are disturbed from position replace with new.

The following steps are for pumps with a bearing frame.

17. Remove socket head bolt (*800D) fastening bearing cap (*35) to bearing frame (*19). Remove bearing cap from bearing frame.
18. Remove coupling (*42) from shaft (*6).
19. Remove the shaft (*6) (with radial and thrust ball bearing assemblies) from the bearing frame (*19).
20. Uncrimp tang on bearing lockwasher (*69) and remove bearing locknut (*22) and bearing lockwasher.

NOTE

If ball bearings are disturbed from position replace with new.

21. If desired, pull ball bearing (*18) from shaft (*6).
22. If desired, pull ball bearing (*16) from shaft (*6).

C. PARTS INSPECTION.

1. All parts should be thoroughly cleaned with a suitable solvent or replaced with new ones if necessary.
2. All sealing faces should be perfectly clean. All ball bearings, mechanical seals, gaskets, O-rings, lip seals, and locking devices with a nylock feature are to be replaced with new if disturbed from position.
3. Check shaft for runout, scratches, grooves, or any possible damage. Touch up scratches and grooves with a polishing cloth and inspect for remaining grooves or deep scratches. A bent or excessively damaged shaft should be replaced.
4. Inspect the casing for pitting, scoring, and erosion. The inside of the casing should be free of any pits or grooves. The maximum allowable depth is 1/8" (3mm). Replace the casing if any of these defects are present.
5. If the suction cover on an open impeller pump shows excessive wear on the face due to abrasion or corrosion, and performance cannot be restored, replace suction cover.
6. Inspect and replace any defective grease fittings.

7. Inspect mechanical seal. Replace the mechanical seal that is disturbed from position or damaged.
8. Inspect the impeller and bushing keys for distortion and push fit into keyways. The keys should be square on all four edges. They should fit without having to be forced. The keys should not rock in keyway. Replace keys or shaft if necessary.
9. Inspect ball bearings (16 and 18) for damage. A damaged bearing must be replaced. If a bearing is removed from the shaft, it is recommended that the bearing be replaced. If bearing replacement is not possible and bearing is in good condition bearing should be cleaned and protected until ready to use. Refer to Section X, Paragraph A.
10. Check the shaft sleeves and spacer sleeves visually for score marks, scratches, pits, grooves or burrs. Touch up sleeves with polishing cloth and inspect for remaining grooves or deep scratches. Remove burrs with a file. Shaft sleeves and spacer sleeves should be replaced if any marks, pits or grooves are still visible after touching up.
11. Inspect tubing for kinking. Replace kinked tubing.
12. If the impeller shows excessive wear due to erosion or pitting, so that performance cannot be restored, it must be replaced. If a new impeller is installed, check to make sure that it is balanced and of the correct trim. If an impeller is restored or replaced check the dynamic balance of the rotor before reassembly of the pump.
13. If enclosed impeller (2) is equipped with optional wear rings, check the wear ring clearance as follows:
 - a. Measure outside diameter of front impeller hub (2) in three places.
 - b. Measure inside diameter of wear ring (7) in three places.
 - c. If difference between the high reading of the inside diameter of the wear ring (7) and the low reading of the outside diameter of the impeller (2) wear ring exceeds double the new maximum clearances given in Table 6, replace the wear ring according to Section XI, Paragraph G.
 - d. Measure outside diameter of back impeller hub (2) in three places.
 - e. Measure inside diameter of the backcover wear ring (7X) in three places.
 - f. If difference between the high reading of the inside diameter of the backcover wear ring (7X) and the low reading of the outside diameter of the back impeller (2) wear ring exceeds double the new maximum clearances given in Table 7, replace the back wear ring according to Section XI, Paragraph G.

Table 7. Enclosed Impeller Clearance

Pump Size	Front Wear Ring Clearance (Inches)	Back Wear Ring Clearance (Inches)
1-1/4 X 1 X 5	.009/.014	N/A
2 X 1-1/2 X 5	.012/.016	N/A
2-1/2 X 2 X 5	.012/.016	N/A
1-1/4 x 1 x 7	.012/.016	N/A
1-1/2 x 1-1/4 x 7	.014/.018	N/A
2-1/2 x 2 x 7	.012/.016	N/A
3 x 2-1/2 x 7	.014/.018	N/A
4 x 3 x 7	.014/.018	.012/.016
5 x 4 x 7	.015/.020	.012/.016
1-1/2 x 1-1/4 x 10	.011/.014	N/A
2 x 1-1/2 x 10	.012/.016	N/A
2-1/2 x 2 x 10	.012/.016	N/A
3 x 2-1/2 x 10	.012/.016	.012/.016
4 x 3 x 10	.012/.016	.012/.016
5 x 4 x 10	.012/.016	.012/.016
6 x 5 x 10	.021/.026	.021/.026
2 x 1 x 11	.012/.015	.012/.015
4 x 2 x 11	.016/.020	.016/.020
4 x 3 x 11	.016/.020	.016/.020
5 x 4 x 11	.016/.020	.016/.020
8 x 6 x 11	.019/.023	.019/.023
2-1/2 x 1-1/2 x 13	.020/.023	N/A
2-1/2 x 2 x 13	.020/.024	.020/.024
3 x 2-1/2 x 13	.016/.020	.014/.018
4 x 3 x 13	.017/.020	.014/.018
5 x 4 x 13	.018/.022	.014/.018
6 x 5 x 13	.017/.021	.014/.018
8 x 6 x 13 (frame mounted only)	.019/.022	.014/.018

D. REASSEMBLY OF PUMP. Read this entire section before reassembling the pump. The instructions that follow are an aid for properly trained personnel to assemble your Carver Pump. Refer to Figures 9 and 10 to locate the pump parts by item number and parts list Table 9. If a specific sectional assembly drawing exists for a particular job, then that drawing should be referred to for assembly. Refer to Table 5 for recommended torque values. Assemble the pump in accordance with accepted rules of engineering practice. Coat individual components with a suitable lubricant before assembling. Assembly of unit should be performed on a clean, flat surface. During reassembly, install parts as applicable.



CAUTION

During reassembly, install new O-rings, ball bearings, packing, mechanical seal and gaskets if disturbed from position. O-rings, ball bearings, packing, mechanical seal and gaskets may have been damaged during disassembly.

While installing ball bearings, DO NOT unnecessarily hit ball bearings. If damage to ball bearings occurs, replace damaged ball bearings with new ball bearings.

After 12,500 hours of service, replace the ball bearings.

NOTE

To ensure proper seating of ball bearing parts, rotate the ball bearing while clamping the parts.

All parts should be thoroughly cleaned or replaced with new ones if necessary. All sealing faces should be perfectly clean, but do not scratch or alter surface finish on seal faces.

Variations do exist between configurations, not all parts described in the text may be on your configuration. Review what variations your pumping unit has before starting. Parts marked with * are options or vary by pump.

For close-coupled units start reassembly with step 7.

NOTE

Replace bearing (*16 or *18), once removed from shaft (*6). If ball bearing replacement is not possible and bearing is in good condition, clean bearing in accordance with Section X, Paragraph A.

1. If removed, hand pack ball bearings (*16 and/or *18) half full with the proper grease, refer to Section X, Paragraph A. Install ball bearings onto shaft (*6) with open sides of ball bearings facing away from larger diameter of shaft.
2. Install bearing lockwasher (*69) and bearing locknut (*22) on inboard end of shaft. Crimp tang of bearing lockwasher into one of the grooves provided in the bearing locknut.
3. Install the shaft (*6) in the bearing frame (*19).
4. Install bearing cap (*35) on bearing frame (*19) securing it to the bearing frame with socket head bolts (*800D). Refer to Table 5 for recommended torque values.
5. Lubricate pump by inserting grease into grease zerks in bearing frame (*19), refer to Section X, Paragraph A.
6. If removed, install the slinger (40) on shaft (*6) next to adaptor (71).
7. Lubricate and install sleeve O-ring (700D) onto shaft (*6).

NOTE

Refer to mechanical seal vendor instructions for complete seal installation procedure.

8. As applicable, the stationary element of mechanical seal (*90) should be installed in the gland (17) before the gland is installed, refer to Section XI, Paragraph F for procedures. Install gland on shaft (*6), slide back towards slinger (40).
9. If mechanical seal (*90) was removed lubricate outside of shaft sleeve (14) to facilitate mounting of mechanical seal. Install mechanical seal on shaft sleeve. Rotating element of mechanical seal if not being replaced will be on shaft sleeve.
10. Coat shaft sleeve (14) bore with DOW 111 and install shaft sleeve over O-ring (700D) onto shaft (6).

NOTE

For a cartridge seal, refer to mechanical seal vendor instructions for proper seal installation procedure.

11. If applicable, install cartridge mechanical seal (*90). DO NOT remove seal clip until after pump assembly is complete.
12. For units with packing (*13), install the packing retaining ring (*63) into the back cover (11). Install the lantern ring (*29) on the shaft sleeve (14) sliding the lantern ring back near the slinger (40).
13. As applicable, install the mechanical seal spacer (*68) or packing retaining ring (*63) onto shaft sleeve (14).
14. Install sleeve gasket (73A).
15. Install O-ring (700A) on back cover (11).
16. Install back cover (11) on adaptor (*71) and secure with bolts (800C).

**CAUTION**

During steps 17 through 21b, use old impeller capscrew (24) to secure impeller (2 or 3). Once proper impeller clearance is achieved, use a new impeller capscrew (24) to secure impeller.

During assembly, install new impeller capscrew (24) with locktite.

NOTE

Impeller gasket installation is critical to Dry Shaft design. Insufficient gasket thickness may allow liquid to access the end of the shaft. Excessive gasket thickness may allow liquid ingress to shaft area behind the impeller. DO NOT reuse PTFE gaskets.

17. Install impeller key (32). Coat impeller (2 or 3) bore with DOW 111 and install impeller. Install impeller washer gasket(s) (73C) in impeller bore over the end of the shaft (*6), combining thicknesses and quantities, as required, so the outer most gasket face protrudes from the impeller bore by approximately .02 to .04 inches when the impeller/sleeve/gasket are lightly compressed. Install impeller capscrew O-ring (700C) and impeller washer (28) on impeller capscrew (24). Install and properly torque impeller capscrew (24).

**CAUTION**

Use a two-man lift or suitable lifting device to lift pumping unit, motor, or assemblies.

18. Install casing (1) to back cover (11) with bolts (800B).
19. Using appropriate leveling tools, level casing. Torque bolts (800B), (800C), and (800D*), refer to Table 5.

NOTE

On pumps equipped with a closed impeller, omit steps 20 through 21d. Steps 20 through 21d are procedures that describe impeller clearance adjustment for semi-open impellers only.

20. Install suction cover (9) to casing (1). DO NOT install suction cover gasket (73B).
21. There must be a clearance of 0.010 inches minimum and 0.020 inches maximum between semi-open impeller (3) and suction cover (9). To check clearance, rotate shaft by hand and listen for any rubbing noise.

If rubbing noises are present, the clearance between impeller and suction cover is less than 0.010 inches. To remedy this:

- a. Remove bolts (800A) and suction cover (9).
 - b. Install new suction cover gasket (73B) on suction cover (9).
 - c. Install suction cover (9), securing with bolts (800A).
 - d. Recheck the clearance and repeat the above steps as necessary to correct the clearance between the impeller (3) and the suction cover (9) and there is no more rubbing. The maximum number of suction cover gaskets (73B) to be used is 5. Consult the factory if more than 5 are needed.
22. After proper clearance is achieved make sure that the suction cover (9) is installed with the vent hole to the top and tighten bolts (800A).
 23. Complete mechanical seal (*90) or packing (*13) installation. As applicable, ensure tap flush lines in gland (*17) are positioned so flush lines can be connected. Install gland on studs (820) and evenly tighten gland hex nuts (830) and gland flat washers (850). Install tubing and tubing fittings, as applicable.

24. Check for smooth shaft rotation. Install splash guard (*132) in bearing frame (*19) or adaptor (*71).

! CAUTION

Use a hoist with adequate lifting capacity; refer to Section VII, Paragraph B, for lifting the pump.

25. Return pumping unit to installation site. Install pumping unit on its base and secure to base with foundation bolts.
26. On frame-mounted pumps, align coupling (*42) in accordance with Section VII, Paragraph F. Reconnect coupling. Install coupling guard (*131).
27. Reconnect piping and gauges, as necessary. Remove all tags from valves and switches. Open system valves. Reconnect power supply to motor.
28. Start pumping unit in accordance with section IV, Operation.

E. REPLACEMENT OF PACKING. Pumps equipped with packing have a lantern ring which is located in line with the flush water connection on the stuffing box. Flow should be adjusted, typically to 20 to 30 drops per minute. Flush water pressure should be approximately 70 kPa (10 PSI) more than the pump discharge pressure to ensure flow of water through the packing. Use the following procedure when replacing the packing:

1. Ensure the new packing is of proper type and size.
 - a. Typical is five rings, 6mm x 6mm (3/8" x 3/8").
 - b. Standard shaft diameter is 32mm (1 1/4").
 - c. Pre-cut sets of packing and lantern rings are available for stock from Carver Pump Company
2. Stop the pumping unit; refer to Section VIII, Paragraph E.
3. Carefully bleed off pressure and remove splash guard (*132A).
4. Remove gland hex nuts (830) and the gland flat washers (850) on studs (820). Slide back and remove gland (17) halves.

! CAUTION

Do not use system pressure to blow out (remove) packing.

5. Refer to Figure 6; remove all old packing rings (13) by using the proper size packing removal hook. The lantern ring (29) will remain on the shaft (6) and should be slid near the slinger (40).

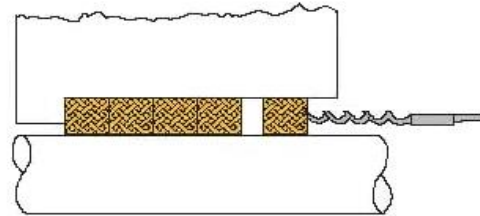

Figure 6. Removing Packing with Hook

6. Check the shaft (6) for nicks and score marks; repair or replace as necessary.
7. If required, clean the stuffing box bore.
8. Install the first ring of packing (13) with joint at approximately the 1 o'clock position (30° right of vertical). Refer to Figure 7 for packing alignment.

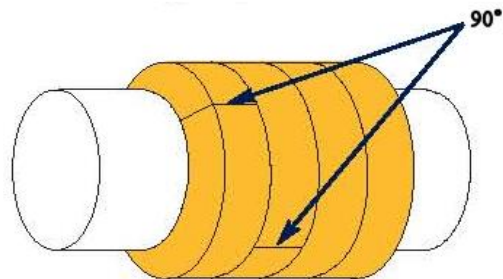

Figure 7. Packing Alignment

9. Twist the ring of packing (13) slightly in an "S" shape and place it around the shaft (6).
10. Seat packing (13) firmly against bottom of stuffing box using the gland (17).
11. Repeat procedure as described in Steps 8 through 10. Packing (13) ring joints should be staggered 90° apart.
12. Install enough rings (typically 2) until lantern ring will align with flush water port.
13. Slide lantern ring (29) back up shaft (6) into position.

14. Install remaining packing (13) as described in Steps 8 through 10 above.

NOTE

In tightening the gland (17), gland hex nuts (830) should be adjusted evenly to avoid cocking the gland and subjecting the packing (13) to uneven pressure.

15. Seat final ring of packing (13) firmly with the gland (17) halves. Install the gland flat washers (850) and gland hex nuts (830) on studs (820) using a wrench to tighten.
16. Ensure that lantern ring (29) is still properly aligned with the flush port.
17. Loosen gland hex nuts (830) and retighten, using only fingers.
18. At minimum the gland (17) should be into the stuffing box approximately 3 - 5mm (1/8" - 3/16").
19. The remaining exposed portion of gland (17) follower should be at least 6mm (1/4") to allow future gland adjustments.
20. Rotate shaft (6) by hand to ensure shaft is not binding.
21. Allow liberal leakage at start up.
22. Slowly adjust leakage to an acceptable level by tightening gland hex nuts (830) slowly and evenly. Final adjustments should be made by rotating gland hex nuts one flat at a time.

NOTE

If stuffing box is hot to the touch (approximately 65°C or 150°F), there is not enough flush water entering the stuffing box.

23. Packing (13) may run warm during break-in period, one day or two.
24. Do not adjust the packing (13) unless necessary.
25. If uncontrolled excessive leakage occurs, lantern ring (29) is pushed out of alignment with flush water port, or gland (17) follower cannot be tightened further, re-pack the pump.

F. REPLACEMENT OF MECHANICAL SEAL. A mechanical seal (90) must be installed and serviced while the casing (1) is removed from the motor or bearing frame (19) or adaptor (71).

Mechanical Seal Removal

NOTE

Refer to mechanical seal vendor instructions for proper mechanical seal removal procedure.

Disassemble pump per Section XI, Paragraph B. steps 1 through 11. Take special care with the mechanical seal (90) rotary and stationary elements when sliding the casing (1) off of the shaft (6).

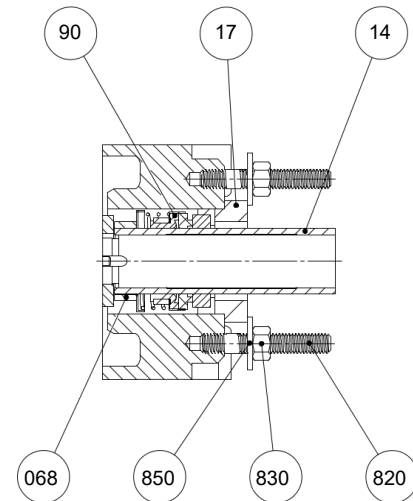

Figure 8. Mechanical Seal

Mechanical Seal Installation

1. Lubricate and install sleeve O-ring (700D) onto shaft (6).

NOTE

For a cartridge seal, refer to mechanical seal vendor instructions for proper seal installation procedure.

2. If applicable, install cartridge mechanical seal (90*). DO NOT remove seal clip until after pump assembly is complete.

NOTE

Refer to mechanical seal vendor instructions for complete seal installation procedure.

3. If stationary element of mechanical seal (90) is to be replaced, clean, dry, and lubricate gland (17). Lubricate stationary element of mechanical seal with suitable lubricant. Insert stationary element of mechanical seal into gland.

4. Install gland (17) on shaft (6), slide back towards slinger (40).
5. Install casing (1) to bearing frame (19) with bolt (800C) or adaptor to motor (200) with bolt (*800D).
6. Lubricate outside of shaft sleeve (14) to facilitate mounting of mechanical seal (90). Install mechanical seal rotating elements on shaft sleeve.
7. Coat shaft sleeve (14) bore with DOW 111 and install shaft sleeve over O-ring (700D) onto shaft (6).
8. Slide gland (17) with stationary elements of mechanical seal (90) onto studs (820) and secure finger tight with gland hex nuts (830) and washers (850). As applicable, ensure tap flush lines in gland (17) is positioned so flush lines can be connected.
9. Reassemble pump per Section XI, Paragraph D, steps 15 through 28.

G. REPLACEMENT OF OPTIONAL WEAR RING ON PUMP EQUIPPED WITH ENCLOSED IMPELLER.

If your pump is equipped with an enclosed impeller, it may have an optional, replaceable wear rings (7) in the suction cover (9) or back cover (11). If your pump is equipped with the optional wear rings (7), use the following instructions, Table 8 and Figure 6 for wear ring replacement.

NOTE

Stainless fitted and all iron pumps are not fitted with a separate wear ring when new from the factory. Stainless fitted and all iron pumps when rebuilt can use separate wear rings to restore wearing surface in the backhead or suction cover.

The clearance between the wear rings (7) and impeller (2) hub will increase with wear. Internal leakage will result and pump performance will decrease.

Table 8. Impeller/Wear Ring Matching Materials

IMPELLER MATERIAL	WEAR RING MATERIAL
All Iron & Stainless Fitted	Cast Iron (Suction Head)
Bronze	Cast Iron (Suction Head)
Stainless Steel	17-4PH Stainless Steel

To replace the wear ring, follow the disassembly procedures in Paragraphs A and B of this section to the point where the back cover or suction cover has been

removed and the wear ring is accessible. Once the wear ring is accessible, use the following procedures:

1. Remove wear ring (7) from suction cover (9). This can best be accomplished on a lathe.
2. Inspect impeller (2) hub for damage.
3. Press new wear ring (7) into suction cover (9). Beveled edge of wear ring (7) is installed toward impeller (2).
4. Place impeller (2) on an arbor and mount between centers in a lathe or a grinder. Indicate back of impeller (2) hub to within 0.002 T.I.R. maximum to be sure arbor and impeller (2) are running square.
5. Turn wearing surface of impeller (2) until a 63 RMS or better finish is obtained.
6. Measure outside diameter of front impeller (2) hub and record the value.
7. Mount suction cover (9) with new wear ring (7) installed in a lathe. Indicate male rabbet to within 0.002 T.I.R. maximum.
8. Bore wear ring (7) to within specified tolerance (listed in Table 6) over recorded size of outside diameter of front impeller (2) hub.



CAUTION

Use removable thread locker when installing impeller capscrew.

H. MOTOR. The motor should be maintained in accordance with the manufacturer’s instructions.

I. CHECK VALVE. If applicable, the check valve should be maintained in accordance with the manufacturer’s instructions.

XII. PARTS LISTS AND DRAWINGS.

This section contains listings of parts and corresponding drawings. Table 9 notes the recommended spare parts for this pumping unit. Refer to Figures 9 and 10, for the location of parts identified by item numbers.

Table 9. Parts List

Item Number	Description	Item Number	Description
1	Casing	*69	Bearing Lockwasher
*2	Impeller, Enclosed	*71	Adaptor
*3	Impeller, Semi-Open	73A	Gasket, Sleeve
*6	Shaft	*73B	Gasket, Suction Cover
*7	Wear Ring	73C	Gasket, Impeller
9	Suction Cover	*90	Mechanical Seal
11	Back Cover	700A	O-Ring, Backcover
*13	Packing	*700B	O-Ring, Suction Cover
14	Shaft Sleeve	700C	O-Ring, Impeller
*16	Ball Bearing, Radial	700D	O-Ring, Shaft Sleeve
17	Gland	*131**	Coupling Guard
*18	Ball Bearing, Thrust	132**	Splash Guard, Bearing Frame/Intermediate
*19	Bearing Frame	*200	Electric Motor
*22	Bearing Locknut	550	Pipe Plug, Casing
24	Impeller Screw	800A	Capscrew – Suction Cover/Casing
28	Impeller Screw Washer	800B	Capscrew – Casing/Backcover
*29	Lantern Ring (For Units with Packing)	800C	Capscrew – Bracket/ Backcover
32A	Key, Impeller	*800D	Capscrew – Adaptor/Motor
*32B	Key, Coupling	*804D	Socket Head Bolt – Bearing Cap
*35	Bearing Cap	820	Stud - Gland
40	Slinger	830	Hex Nut - Gland
*42**	Coupling	850	Washer - Gland
*68	Collar - Mechanical Seal		

* Parts are options that vary by pumping unit. ** Not shown

Table 10. Recommended Spare Parts List

Item Number	Description	Item Number	Description
2 or 3	Impeller	*69	Bearing Lockwasher
*6	Shaft	73A	Gasket, Sleeve
*13	Packing	*73B	Gasket, Suction Cover
14	Shaft Sleeve	73C	Gasket, Impeller
*16	Ball Bearing (Radial)	*90	Mechanical Seal
*17	Gland	700A	O-Ring, Back Cover and Suction Cover
*18	Ball Bearing (Thrust - Impeller End)	700C	O-Ring, Impeller
32A	Key, Impeller	700D	O-Ring, Shaft Sleeve
*32B	Key, Coupling		

* Parts are options that vary by pumping unit.

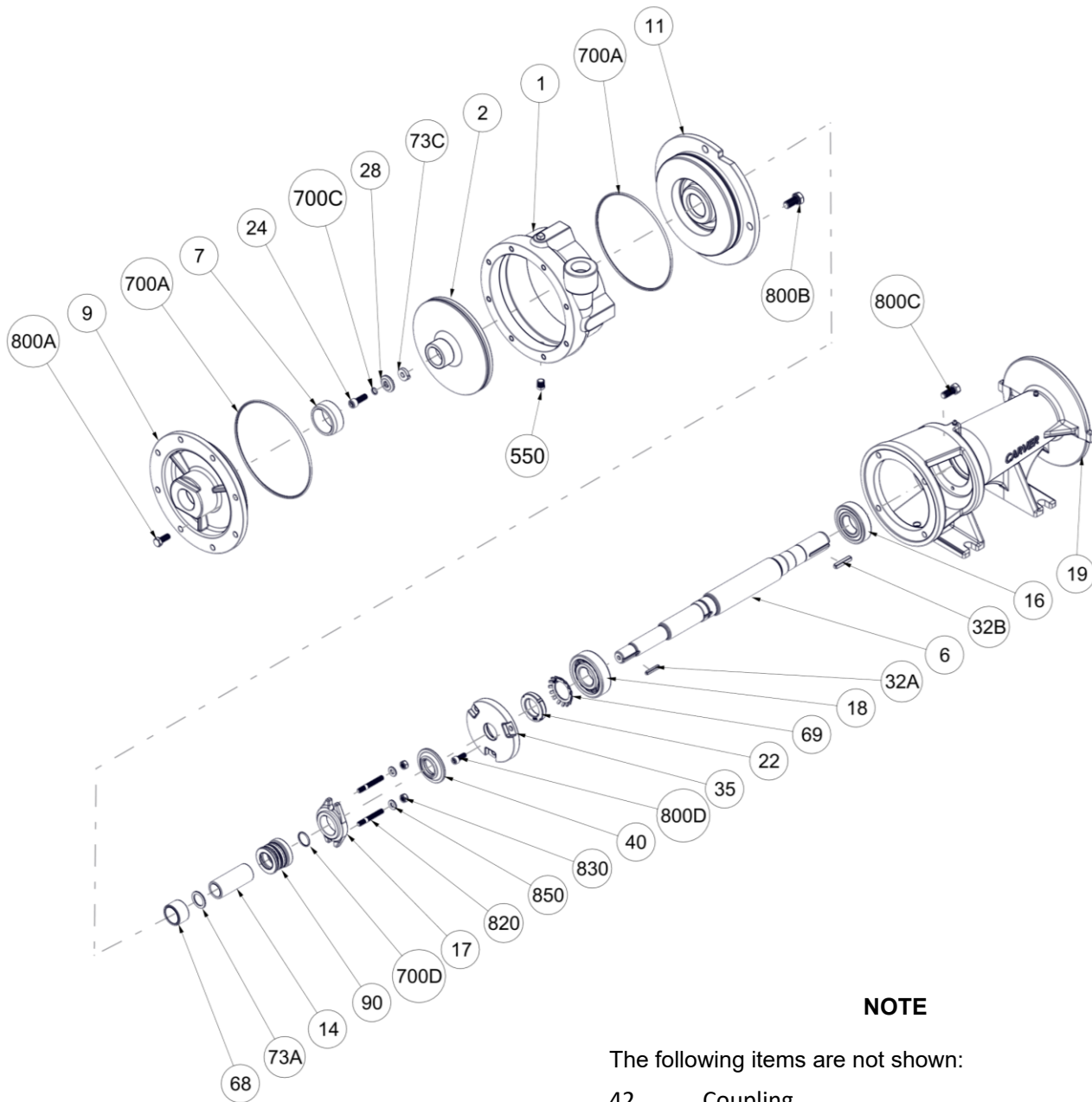
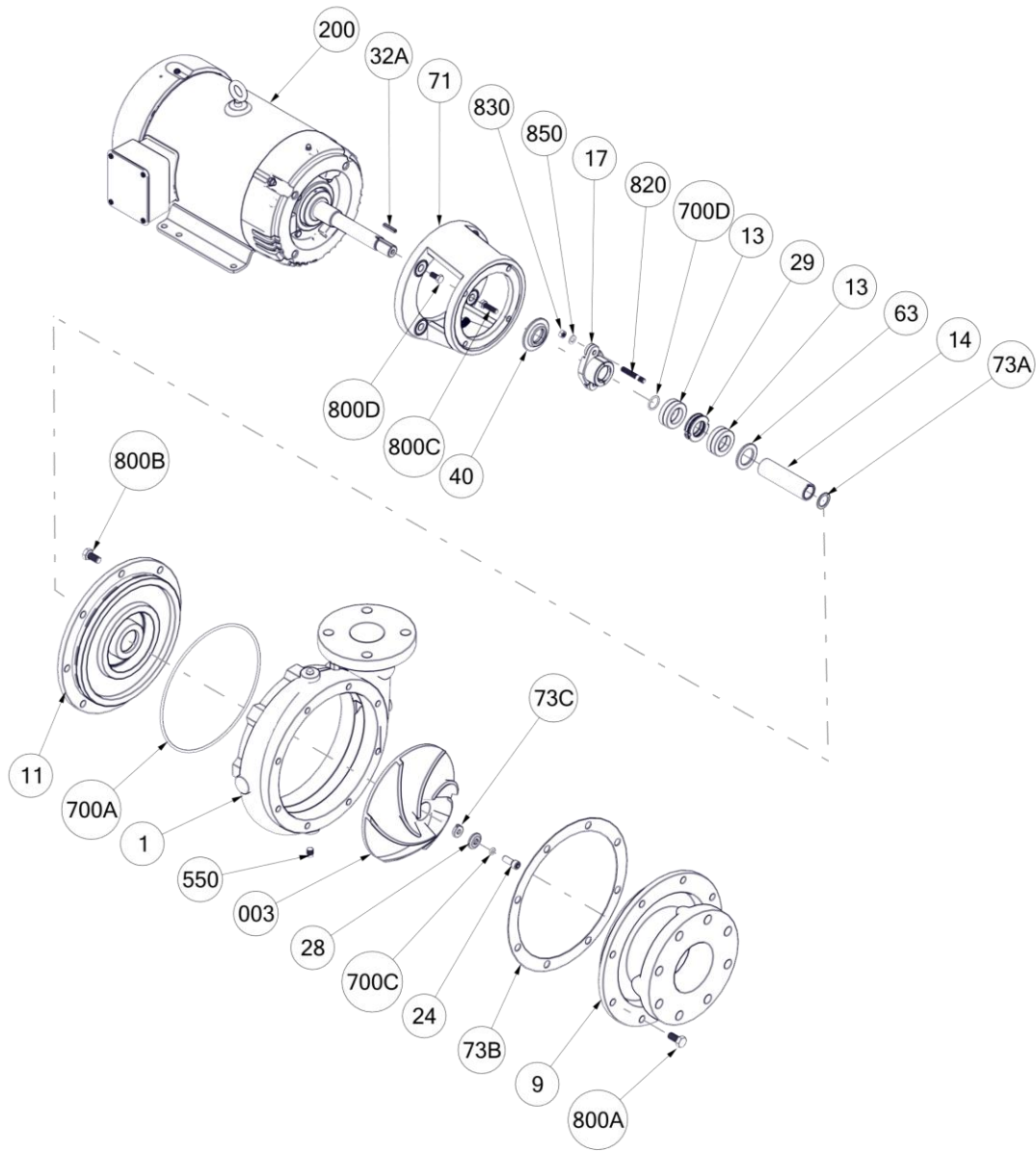

Figure 9. Exploded View – Frame Mounted (Shown with Mechanical Seal)



NOTE

The following item is not shown:

132 Splash Guard, Intermediate

Figure 10. Exploded View – Close-Coupled (Shown with Packing)



CARVERPUMP™
Built for purpose

2415 Park Avenue, Muscatine, IA 52761
Phone: 563.263.3410 www.carverpump.com

I-120 IOM
120 – 16.05.EN