



**I-100**  
100 – 19.01.EN

## ***GHJM Close-Coupled Pump***

# **INSTALLATION, OPERATION AND MAINTENANCE INSTRUCTIONS**

Part Number: \_\_\_\_\_

Serial Numbers: \_\_\_\_\_

 These operating instructions contain fundamental information and precautionary notes. Please read the manual thoroughly prior to installation of unit, electrical connection and commissioning. It is imperative to comply with all other operating instructions referring to components of individual units.

 This manual shall always be kept close to the unit's location of operation or directly on the pump set.

This page intentionally left blank.

**SERVICE RECORD PAGE**

Service No. \_\_\_\_\_ Model \_\_\_\_\_ Size and Type \_\_\_\_\_

Customer Order No. \_\_\_\_\_ Date Installed \_\_\_\_\_

Installation Date	Location	Application

**PUMP RATING**

Capacity \_\_\_\_\_ Total Head \_\_\_\_\_

Suction Pressure \_\_\_\_\_ Speed (RPM) \_\_\_\_\_

Liquid pumped \_\_\_\_\_ Temperature \_\_\_\_\_

Specific Gravity \_\_\_\_\_ Viscosity \_\_\_\_\_

Service \_\_\_\_\_

**PUMP MATERIALS**

Casing \_\_\_\_\_ Impeller \_\_\_\_\_ Shaft \_\_\_\_\_

Gaskets \_\_\_\_\_ Bearing Frame \_\_\_\_\_

Mechanical Seal/Packing \_\_\_\_\_ P/N \_\_\_\_\_

**MOTOR DATA**

Motor \_\_\_\_\_ Make \_\_\_\_\_ Serial No. \_\_\_\_\_

Type \_\_\_\_\_ Frame \_\_\_\_\_ AC or DC \_\_\_\_\_

HP \_\_\_\_\_ RPM \_\_\_\_\_ Volts \_\_\_\_\_

Phase \_\_\_\_\_ Cycles \_\_\_\_\_ P/N \_\_\_\_\_

**NOTES ON INSPECTION AND REPAIRS**

INSPECTION DATE	REPAIR TIME	REPAIRS	COST	REMARKS

# INSTALLATION, OPERATION AND MAINTENANCE INSTRUCTIONS

## TABLE OF CONTENTS

SECTION/PARAGRAPH	PAGE	SECTION/PARAGRAPH	PAGE
I. GENERAL DESCRIPTION AND SAFETY		B. Handling .....	6
PRECAUTIONS.....	1	C. Foundation .....	6
A. General Information .....	1	D. Leveling of Unit .....	6
B. Machinery Directive 2006/42/EC .....	1	E. Pre-Installation Procedures .....	7
C. Disclaimer .....	1	F. Piping .....	7
D. Personnel Qualification and Training .....	1	G. Auxiliary Piping Connection and Gauges .....	7
E. Pump Identification.....	2	H. Motor .....	7
F. Parts Inventory Guide .....	2	I. Direction of Rotation .....	7
G. Parts Ordering.....	2		
H. Unauthorized Modification and Manufacture of Spare Parts .....	2	VI. OPERATION .....	8
I. Unauthorized Modes of Operation .....	2	A. Pre-Start Cautions .....	8
		B. Priming .....	8
II. SAFETY .....	2	C. Starting the Pump .....	8
A. Safety Precautions .....	2	D. Operating Checks .....	9
B. Summary of Safety Marking.....	2	E. Stopping the Pump .....	9
C. Non-Compliance with Safety Instructions ..	3	F. Emergency Shutdown.....	9
D. Avoid Possible Non-Conformance .....	3	G. Indefinite Shutdown .....	9
E. Safety Awareness .....	3		
F. Safety Instructions for the Operator/User ..	3	VII. TROUBLESHOOTING OPERATING PROBLEMS.....	9
G. Safety Instructions for Maintenance. Inspection, and Installation Work .....	3		
H. Unauthorized Modes of Operation .....	4	VIII. MAINTENANCE .....	11
		A. Lubrication of Motor Bearings.....	11
III. EFFECTS OF FLUIDS .....	4	B. Torque Values.....	11
A. Net Positive Suction Head (NPSH).....	4		
B. Changing Pump Speed .....	4	IX. SERVICE AND REPAIR.....	11
C. Effects of Viscosity .....	4	A. Preparations for Disassembly of Pump .....	12
D. Effects of Specific Gravity .....	5	B. Disassembly of Pump .....	12
		C. Parts Inspection .....	14
IV. INSPECTION AND STORAGE .....	5	D. Reassembly of Pump.....	15
A. Inspection.....	5	E. Motor .....	18
B. Packing for Return .....	5		
C. Storage of Pump .....	5	X. PARTS LISTS.....	18
V. INSTALLATION .....	6		
A. Location.....	6		

**TABLE OF CONTENTS - Continued**

<b>LIST OF TABLES</b>			<b>LIST OF ILLUSTRATIONS</b>		
<b>NUMBER</b>	<b>TITLE</b>	<b>PAGE</b>	<b>NUMBER</b>	<b>TITLE</b>	<b>PAGE</b>
1.	Pumping Unit Troubleshooting .....	10	1.	Sling Position for Lifting Pump.....	6
2.	Recommended Torque Values .....	11	2.	Sling Position for Lifting Pumping Unit .....	6
3.	Recommended Equipment .....	11	3.	Reference Exploded View, Enclosed Impeller .....	18
4.	Factory Wear Clearance (Inches).....	15	4.	Reference Exploded View, Semi-Open Impeller.....	19
5.	Seal Retainer Tool Parts List .....	16			
6.	Parts List .....	19			
7.	Recommended Spare Parts .....	20			

## I. GENERAL DESCRIPTION AND SAFETY PRECAUTIONS.

**A. GENERAL INFORMATION.** Carver Pump Company products are carefully engineered and manufactured and, if properly installed, maintained, and operated, should provide maintenance-free operation and a long service life. Factory warranty applies to pumps operating under conditions specified on the order acknowledgement, and that are properly installed and maintained, as recommended in this manual.



### **CAUTION**

These instructions must always be kept close to the product's operating location or directly with the product.

This manual is designed to provide sufficient material to properly maintain the total pumping unit. The information presented should improve your knowledge and understanding of the GHJM Close-Coupled Pumps, thus upgrading the reliability, service life, and quality of pump maintenance.

These operating instructions do not take into account local regulations; the operator must ensure that such regulations are strictly observed by all, including the personnel called in for installation. Compliance with such laws relating to the proper installation and safe operation of the pumping equipment is the responsibility of the equipment owner and all necessary steps should be taken by the owner to assure compliance with such laws before operating the equipment. These instructions are intended to facilitate familiarization with the product and its permitted use to help satisfy safety requirements. Always coordinate repair activity with operations personnel and follow all ship safety requirements and applicable safety and health laws/regulations.

Refer to the exploded view Figure 3, for the location of parts identified by item numbers. Variations do exist between configurations, not all parts described in the text may be on your configuration.



### **CAUTION**

These instructions should be read prior to installing, operating, using and maintaining the equipment in any region worldwide and in conjunction with the main user instructions provided. The equipment must not be put into service until all the conditions relating to safety instructions have been met.

**B. MACHINERY DIRECTIVE 2006/42/EC.** This product is designed to Conform with Machinery Directive 2006/42/EC, Safety of Machinery EN ISO 12100:2010, EN ISO 13732-1:2008, EN 626-1:2008, EN ISO 13857:2008, and the EHSRs.

Complete Machinery for use in EU and EAA will have CE mark and Declaration of Conformity. Motors for CE marked pumps will have motors that are marked to confirm that they comply with the Low Voltage Directive 2006/95/EC.



### **CAUTION**

Pumps assembled without a motor will have a Declaration of Incorporation and will not have a CE mark. When a motor is added, all guards must be installed, the motor must be CE marked and the completed machine reviewed for compliance for applicable EHSRs before a CE mark is attached.

### **NOTE**

Since 29 December 2009 Directive 2006/42/EC has regulated the placing on the market, and the putting into service, of machinery in the EEA, replacing Directive 98/37/EC.

**C. DISCLAIMER.** Information in these User Instructions is believed to be reliable. In spite of all the efforts of Carver Pump Company to provide sound and all necessary information the content of this manual may appear insufficient and is not guaranteed by Carver Pump Company as to its completeness or accuracy.

**D. PERSONNEL QUALIFICATION AND TRAINING.** All personnel involved in the operation, installation, inspection and maintenance of the unit must be qualified to carry out the work involved. If the personnel in question do not already possess the necessary knowledge and skill, appropriate training and instruction must be provided. If required the operator may commission the manufacturer/supplier to provide applicable training.

Follow instructions in this manual carefully. Factory warranty applies only when pump operates under conditions as specified on order acknowledgment, and if pump is properly installed and maintained as recommended herein. A copy of this manual should be available to operating personnel. Additional copies of this manual are available upon request from Carver Pump Company and your local distributor. For comments and/or questions about information provided,

please contact Carver Pump Company or your local distributor.

**E. PUMP IDENTIFICATION.** The type of pump, pump size, operating data, and serial number are all stamped on the nameplate attached to the pump. Pump specifications should be recorded upon receipt of the pumping unit. Record all necessary information on the pump service record page and inspection and repair record provided at the front of this manual. This information must be included in all correspondence regarding the unit. This will ensure that the correct pump and/or parts are ordered in a timely manner.

**F. PARTS INVENTORY GUIDE.** To avoid unnecessary delays for maintenance, spare parts should be readily available, purchase before and keep in stock, for normal service. Most conditions will be covered if this manual is followed. For every one to three pumps, stock one spare set consisting of items listed in Table 7, Recommended Spare Parts List. For actual part numbers for your unit see the sectional assembly.

**G. PARTS ORDERING.** When ordering replacement parts, please specify:

- Serial number of pump (located on nameplate)
- Part name (Refer to Table 6)
- Part number (Refer to Sectional drawing if available)
- Item number (Refer to Table 6)
- Quantity of parts needed

Carver Pump Company may ship an interchangeable part that is not identical in appearance or symbol. This is done only if the part has been improved. Examine parts carefully upon delivery before questioning factory or company representative. Never return parts to the factory without a Returned Goods Authorization (RGA) Number from Carver Pump Company.

If an impeller is ordered, specify diameter across blade tips. Be sure diameter was NOT trimmed further than diameter shown on the dimensional drawing in Appendix A.

If motor or motor parts are ordered, specify name of manufacturer and all other data found on the motor nameplate.

**H. UNAUTHORIZED MODIFICATION AND MANUFACTURE OF SPARE PARTS.** Modifications or alterations of the pumping unit supplied are only permitted after consultation with Carver Pump and to the

extent permitted by Carver Pump. Original spare parts and accessories authorized by Carver Pump ensure safety. The use of other parts can invalidate any liability of Carver Pump for consequential damage and/or warranty.

**I. UNAUTHORIZED MODES OF OPERATION.** The warranty relating to operating reliability and safety of the unit supplied is only valid if the pumping unit is used in accordance with its designated use as described in the following sections. The limits stated on the nameplate must not be exceeded under any circumstances.

## II. SAFETY

**A. SAFETY PRECAUTIONS.** The manual is designed to provide adequate instructions for the safe and efficient installation, operation, or maintenance of the pump. Failure or neglect to properly install, operate, or maintain the pump may result in personal injury, property damage, or unnecessary damage to the pump. This manual must be read and understood both by the installing personnel and the responsible trained personnel/operators prior to installation and operation, and it must always be kept close to the location of the pumping unit for easy access.

**B. SUMMARY OF SAFETY MARKING.** The safety instructions contained in this manual whose non-observance might cause hazards to persons are specially marked with the symbol:



General hazard sign to ISO 7000 - 0434.

Notes highlight an operating or maintenance procedure, condition, or statement which is essential, but is not of known hazardous nature as indicated by DANGERS, WARNINGS and CAUTIONS.

The word "CAUTION" is used to introduce safety instructions whose non-observance may lead to damage to the machine and its functions.

The word "WARNING" is used to introduce safety instructions whose non-observance may lead to a potential hazard exists, capable of producing injury to personnel, if approved procedures are not followed.

The word "DANGER" indicates a location, equipment, or system where imminent hazards exist, capable of producing immediate injury or death to personnel or threatens the primary mission of the ship.

Instructions attached directly to the machine, e.g.

- Arrow indicating the direction of rotation

- Markings for fluid connections must always be complied with and be kept in a perfectly legible condition at all times.

Observe all note, caution, warning, or danger tags attached to the equipment or included in this manual.

### **C. NON-COMPLIANCE WITH SAFETY INSTRUCTIONS.**

Non-compliance with safety instructions may result in personal injury, property damage, or unnecessary damage to the pumping unit. Non-compliance with these safety instructions will also lead to forfeiture of any and all rights to claims for damages. Non-compliance, can for example, result in:

- Failure of important pumping unit functions.
- Failure of prescribed maintenance and servicing practices.
- Hazard to personnel by electrical, mechanical, and chemical effects as well as explosion.
- Hazard to the environment due to leakage of hazardous substances.

**D. AVOID POSSIBLE NON-COMPLIANCE.** The following specific safety precautions apply to the pumping unit:

- DO NOT exceed maximum discharge pressure on discharge case.
- DO NOT operate pump without fluid to seal or packing.
- DO NOT run pump dry.
- DO NOT run pump against a closed discharge valve.
- DO NOT exceed the Maximum rated speed (3550 RPM).
- A check valve should be installed in the discharge line.
- Pumps assembled by Carver without a motor will have a Declaration of Incorporation and will not have a CE mark. When a motor is added, all guards must be installed, the motor must be CE marked and the completed machine reviewed for compliance for applicable EHSRs before a CE mark is attached.

**E. SAFETY AWARENESS.** It is imperative to comply with the safety instructions contained in this manual, the relevant national and international explosion protection regulations, health and safety regulations and the operator's own internal work, operation, and safety regulations.

### **F. SAFETY INSTRUCTIONS FOR THE OPERATOR /USER.**

- Any hot or cold components that could pose a hazard must be equipped with a guard by the operator.
- Guards which are fitted to prevent accidental contact with moving parts (e.g., coupling) must not be removed whilst the unit is operating.
- Leakages (e.g., at the shaft seal) of hazardous fluids (e.g., explosive, toxic, hot) must be contained to avoid any danger to persons or the environment. Pertinent legal provisions must be adhered to.
- Electrical hazards must be eliminated. (In this respect refer to the relevant safety regulations applicable to different countries and/or the local energy supply companies.)

### **G. SAFETY INSTRUCTIONS FOR MAINTENANCE, INSPECTION, AND INSTALLATION WORK.**

The operator is responsible for ensuring that all maintenance, inspection and installation work be performed by authorized, qualified personnel who are thoroughly familiar with the manual and pumping unit.

The pumping unit must have cooled down to ambient temperature, pump pressure must have been released and the pump must have been drained before working on any pumping unit.

Work on the pumping unit must be carried out during shutdown. The shutdown procedure described in the manual for taking the unit out of service must be adhered to.

Pumps handling fluids that are hazardous to personnel must be decontaminated prior to being worked on.

Immediately following completion of the work, all safety relevant and protective devices must be reinstalled and/or reactivated.

Please observe all instructions set out in the section on start-up before returning the pumping unit to service.

Before operating this equipment, read the following safety precautions, which are to be observed at all times:

- Prior to working on pump or motor, ensure all switches and circuit breakers have been locked in the open (off) position and tagged, "Out of Service."

- DO NOT wear loose clothing or jewelry when working with rotating machines. Secure dog tags, tool belts and anything else which could be pulled into the machinery.
- All circuits should be considered energized (live) and dangerous unless it is absolutely proven to be de-energized (dead).
- DO NOT wear loose or torn clothing around rotating machines.
- In general, try to keep one hand free when servicing electrical equipment.
- When working near electricity, be careful with any metal tools or equipment being used so that they do not touch a live circuit.
- Be sure to de-energize all equipment before connecting or disconnecting any meters or test leads.
- Personnel shall make absolutely certain that they are NOT grounded when adjusting or measuring equipment.
- When connecting a meter to terminals for measurement, always use a range higher than the expected voltage, and then adjust accordingly.
- Before operating this motor or performing any test or measurement, make sure that motor frame and starter panel are securely grounded.
- If a test meter must be held or adjusted while voltage is being applied, ground the case of the meter before starting measurement and DO NOT touch the live equipment while you are holding the meter. Some moving vane type meters should neither be grounded, nor should they be held during measurement. Review meter operating manual before each use.
- DO NOT use test equipment known to be damaged or in poor condition.

### KEEP AWAY FROM LIVE CIRCUITS

Operating personnel must at all times observe all safety regulations. Do not replace components or make adjustments inside the equipment with the high voltage supply turned on. Under certain conditions, dangerous potentials may exist when the power control is in the (OFF) position, due to charges retained by capacitors. To avoid casualties, always remove power and discharge and ground a circuit before touching it.

### DO NOT SERVICE OR ADJUST ALONE

Under no circumstances shall any person reach into or enter the area of the pump for the purpose of servicing or adjusting the equipment except in the presence of someone who is capable of rendering aid.

### RESUSCITATION

Personnel working with or near high voltages shall be familiar with modern methods of resuscitation. Such information may be obtained from the Bureau of Medicine and Surgery.

**H. UNAUTHORIZED MODES OF OPERATION.** The warranty relating to the operating reliability and safety of the unit supplied is only valid if the pumping unit is used in accordance with its designated use as described in the following sections. The limits stated on the nameplate must not be exceeded under any circumstances.

### III. EFFECTS OF FLUIDS.

**A. NET POSITIVE SUCTION HEAD (NPSH).** Any liquid, hot or cold, must be pushed into the impeller of the pump by some absolute pressure, such as the atmosphere or the vessel pressure from which the pump takes its action.

The head in feet of liquid necessary to maintain the required flow into the pump is called the Net Positive Suction Head (NPSH). This value is measured above the vapor pressure of the liquid at the pumping temperature.

NPSH is commonly expressed in two ways: the NPSH required by the pump, and shown on the pump curve, is the head needed to cover the losses in the pump suction and the energy required to enable the liquid to climb onboard the leading edge of the impeller vane. The NPSH available is that inherent in the system, taking into account friction losses in suction piping, valves, fittings, etc. In all cases, the NPSH available, measured above vapor pressure, must exceed the NPSH required in order to push the liquid into the pump.

**B. CHANGING PUMP SPEED.** Changing the speed of a centrifugal pump affects the capacity, total head, NPSH required and the brake horsepower. In general the capacity will vary in a direct ratio with the speed, whereas the total head and NPSH required will vary as the ratio of the speed squared. The brake horsepower will vary as the ratio of the speed cubed.

**C. EFFECTS OF VISCOSITY.** The pump is designed to deliver rated capacity at rated head for a liquid with a

particular viscosity. When pump is handling heavy viscous liquid, the viscosity of the liquid must allow it to be pumped easily. The liquid may have to be heated prior to starting the pump. When contemplating operation at some viscosity other than that for which the pump was originally designed, check with Carver Pump Company.

**D. EFFECTS OF SPECIFIC GRAVITY.** The capacity and total head in feet of liquid developed by a centrifugal pump are fixed for every point on the curve and are always the same for the same speed. Neither capacity nor total head will be affected by a change in the specific gravity of the liquid pumped. However, since the discharge pressure in Pounds per Square Inch (PSI) and the brake horsepower required driving the pump are functions of the specific gravity of the liquid, both will be affected in direct proportion by any change in specific gravity. Therefore, an increase in specific gravity will raise the discharge pressure and is dangerous as it might overload the pump's driver or exceed the pump casing allowable pressure.

#### **IV. INSPECTION AND STORAGE.**

**A. INSPECTION.** Upon receipt of the shipment, unpack and inspect the pumping unit and individual parts to insure none are missing or damaged. Carefully inspect all boxes and packing material for loose parts before discarding them. Immediately report any missing parts or damage incurred during shipment to the factory and to the Transportation Company and file your "damage and/or lost in shipment" claim with the carrier.

**B. PACKING FOR RETURN.** If the pumping unit is sent back to Carver Pump Company for repair, drain the unit, and re-seal all flanges and connections that were covered or plugged. Ship the pump(s) in an assembled condition to prevent damage to sealing faces of individual components. A Return Material Authorization (RMA) number and a Safety Data Sheet (SDS) is required on all returned pumps. Copies of SDS records should be kept and maintained by the customer. The customer is responsible for cleaning and flushing the pump before it is returned to the factory. Make sure to specify the fluid used in the service.

**C. STORAGE OF PUMP.** If the equipment is not to be immediately installed and operated, store it in a clean, dry, well-ventilated place, free from vibrations, moisture and rapid or wide variations in temperature.

Carver Pump Company recommends rotating each motor/pump shaft several revolutions at least once every month. This is done to prevent flat spots on ball bearings and indentations in the race of the ball bearing,

which is termed "false brinelling." False brinelling will lead to premature bearing failure.

#### **NOTE**

Storage requirements vary depending on climatic environment, length of storage and equipment. For storage periods of three months or longer, contact manufacturer for specific instructions. Improper storage could damage equipment and would result in non-warranty covered restoration of non-warranty covered product failures.

The pumping unit is shipped with flange covers to protect flange faces and to prevent foreign matter from entering the pump. Keep flange covers intact until suction and discharge piping are connected to pump flanges.

The motor bearings should be prepared for storage according to the motor manufacturer's instructions, in the motor manufacturer's maintenance manual.

Consider a unit to be in storage when:

1. It has been delivered to the job site and is waiting to be installed.
2. It has been installed but operation is delayed pending completion of construction.
3. There are long (30 days or more) periods between operating cycles.
4. The plant (or department) is shut down for periods of longer than 30 days.

**Measures to be taken for prolonged shutdown of installed pumping unit.** If the pumping unit remains installed a periodic check of operation is in order to make sure that the pump is always ready for instant start-up and to prevent the formation of deposits within the pump and the pump intake area. Start up the pumping unit regularly once a month for a short time (approximately 5 minutes) during prolonged shutdown periods. Prior to operation ensure that there is sufficient liquid available for operating the pump.

**Interim Storage (Indoors)/Preservation.** When the unit is temporarily put into storage, only the wetted low alloy must be preserved. Commercially available preservatives can be used for this purpose. Please observe the manufacturer's instructions for application/removal.

The unit/pump should be stored in a dry room where the atmospheric humidity is as constant as possible. If stored outdoors, the unit and crates must be covered by waterproof material to avoid any contact with humidity.

Protect all stored goods against humidity, dirt, vermin, and unauthorized access!

All openings of the assembled unit components are closed and must only be opened when required during installation. All blank parts and surfaces of the pump are oiled or greased (silicone-free oil and grease) to protect them against corrosion.

## V. INSTALLATION.

**A. LOCATION.** The pump assembly should be located in an area that will permit periodic inspection and maintenance. Sufficient area and access should be provided, and all units should be installed in a dry location with adequate drainage. The discharge piping should be direct with as few elbows and fittings as possible.

The pump assembly should be installed as close to the fluid source as possible. A short, direct suction pipe can be used to keep suction losses at a minimum. If possible, locate the pump so fluid will flow by gravity to the suction opening. The total net positive suction head available (NPSHA), which includes the suction lift and pipe friction losses, must be greater than the net positive suction head required (NPSHR) by the pump.

## B. HANDLING.



### **WARNING**

If the pumping unit slips out of the sling arrangement, it may cause injury to personnel and/or damage to the pumping unit.



### **CAUTION**

Use a hoist with adequate lifting capacity.

Do not pick up the complete unit by the motor or the pump shafts or motor lifting eyes.

Moving the unit requires proper preparation and handling. Always make sure that the pump or the pumping unit remains in a horizontal position while being moved and cannot slip out of the transport suspension arrangement. Use a sling for pumps without baseplates, see Figure 1. To lift a horizontal mounted unit, a hoist or suitable lifting device should be attached to each corner of base structure, see Figure 2. The individual motor may be lifted using proper eyebolts provided by the manufacturer, but these should not be used to lift the assembled unit.

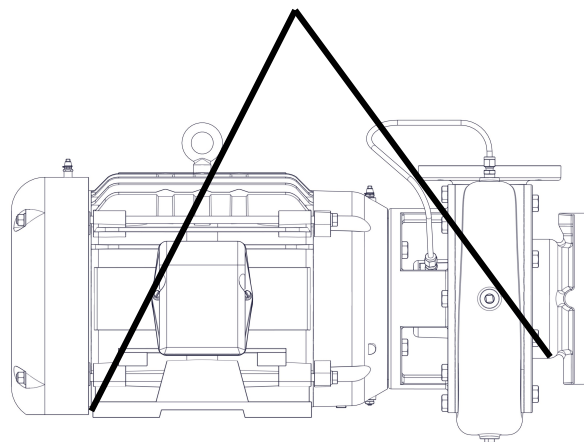

**Figure 1. Sling Position for Lifting Pump**

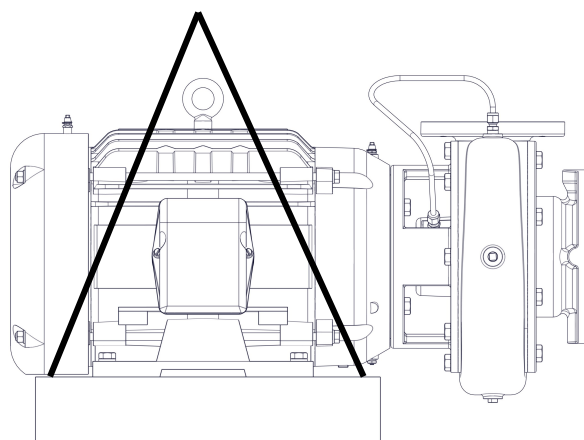

**Figure 2. Sling Position for Lifting Pumping Unit with base**

**C. FOUNDATION.** The foundation should be 3 to 6 inches wider and longer than the baseplate, have a level surface, and be of sufficient mass to prevent vibration and form a permanent rigid support for the unit. This will allow for accurate positioning of the unit.

**D. LEVELING OF UNIT.** When the pump is supplied complete with motor, and baseplate, the unit is assembled at the factory. Lower unit onto foundation, positioning base structure so anchor bolts are aligned in middle of holes in base.

The base plate should be supported on either rectangular metal blocks with shims or on metal wedges having a small taper. The support pieces should be placed close to the foundation bolts. Place supports directly under the part of the base plate, which carries the greatest weight. Space the supports closely enough to provide uniform support of the base plate. Adjust the metal supports or wedges until the discharge flange is

level. Check suction and discharge flanges of the pump by means of a level. Make corrections, as necessary, by adjusting the supports or wedges under the base plate.

The base should be supported on metal shims or metal wedges placed directly beneath the part of the base supporting the most weight. The shims or wedges should be spaced close enough to give support and stability.

Adjust metal supports or wedges until suction and discharge flanges are level.



### **CAUTION**

Do not attempt to straighten the base by using the anchor bolts.

## **E. PRE-INSTALLATION PROCEDURES.**

1. Check the pump foundation and confirm the bolting surface is flat and the bolt pattern is correct.
2. Slowly lower pump onto the foundation.
3. Rotate the pump by hand. Check for any mechanical hesitation, binding or any acoustically transmitted signals from the pump. Hand rotation should be smooth and silent. Install the pump to foundation bolting and tighten to the system torque values. The pump should be rotated frequently during the procedure to tighten down the pumping unit.
4. After the pumping unit has been completely tightened down to the foundation, confirm that there is no binding.
5. Connect the piping.

**F. PIPING.** All piping should be independently supported near the pump so that pipe strain will not be transmitted to the pumping unit.



### **CAUTION**

All piping connections must be made with the pipe in a freely supported state. Do not apply vertical or side pressure to align the piping with the pump flange.

Before connecting suction, discharge, and auxiliary piping, check to see that the piping is absolutely clean internally. Any debris in the piping will be drawn into the pump passageways and can cause extreme damage. The internal diameters of the suction and discharge lines must be equal to the internal diameters of the pump suction and discharge nozzles.

Suction lift lines shall be laid with a rising slope toward the pump and suction head lines with a downward slope towards the pump.

The suction pipe must be air tight and sloped upward to pump flange to avoid air pockets which will impair pump operation. The discharge pipe should be as direct as possible using a minimum number of valves to reduce pipe friction losses.

Never use a straight taper (concentric) reducer in a horizontal suction line because air pockets may form in the top of the reducer and the pipe. Use an offset (eccentric) reducer instead.

It is recommended to install a check valve and closing valve in discharge line and closing valve in suction line, depending on the type of service and pump. The check valve, between the pump and valve, protects pump from water hammer and prevents reverse rotation in the event of power failure. Valve closure is used during priming, starting, and pump shut down. Pump must never be throttled by use of a valve in the suction line.

Thermal expansions of the pipeline must be compensated by appropriate measures so as not to impose any extra loads on the pump exceeding the permissible pipeline forces and moments.

**G. AUXILIARY PIPING CONNECTIONS AND GAUGES.** In addition to primary piping connections, the pump may require other connections such as gauges or drains. All these lines and gauges should now be installed.

**H. MOTOR.** See motor vendor's manual for motor information and information on connecting to the power supply, refer to Appendix B.



### **CAUTION**

Connection to the power supply must be affected by a trained electrician only. Check available main voltage against the data on the motor rating plate and select appropriate start-up method.

**I. DIRECTION OF ROTATION.** Correct pump rotation is indicated by an arrow on the pumping unit. The standard direction of rotation, viewed from the motor end, is clockwise.

## VI. OPERATION.

Before starting or operating the pump, read this entire manual, especially Section II, Safety Precautions.

### A. PRE-START CAUTIONS.



Before activating the pumping unit, check to make sure there are no personnel working on the unit. Serious injury or death to personnel could result if the unit is activated while being worked on.

1. Observe all caution or danger tags attached to the equipment.



Never run the pump dry. Close running fits within the pump are liquid lubricated. Dry running will result in pump seizure or damage.

2. Before starting the pump, rotate shaft by hand to assure all moving parts are free from rubbing.
3. Before starting the pump, install guards to enclose all exposed rotating parts.
4. Before starting the pump, fill the casing and suction line with liquid. The pump is primed in accordance with Section VI, Paragraph B.
5. Before starting a mechanical seal pump equipped with external flush lines, turn on seal water, and confirm the seal water is at sufficient pressure.
6. Make sure all fasteners are torqued to the proper torque values to avoid equipment damage and injury to personnel.

**B. PRIMING.** Dry running a centrifugal pump can result in extensive damage and possible seizing. It is, therefore, imperative that the pump be primed prior to initial start-up and that prime must be maintained through subsequent start-stop cycles.

The priming procedure is different for positive (flooded) and negative suction head (suction lift) systems. Follow the procedure listed below.

#### **Positive Suction Head (Flooded):**

1. Open the vent on the highest point on the pump casing.
2. Open all suction valves.

3. Allow liquid to flow from vent hole until all air bubbles are vented. Then close the vent.
4. The pump is now primed.

#### **Negative Suction Head (Suction Lift):**

1. Install an ejector or vacuum pump on the vent at the highest point on the casing.
2. Close the discharge valve.
3. Open the suction valve.
4. Start the ejector or vacuum pump.
5. Allow liquid to flow until a continuous flow is exhausted from ejector. Then close the valve to the vent.
6. The pump is now primed.

### C. STARTING THE PUMP.



Before activating the pumping unit, check to make sure there are no personnel working on the unit. Serious injury or death to personnel could result if the unit is activated while being worked on.



DO NOT operate pumping unit against a closed discharge system. If pump must operate against a closed system, a bypass system allowing a minimum design flow should be installed. This bypass will be satisfactory for short periods of operation. For extended periods of operation, the bypass should be sized to the minimum continuous flow required by the pump to prevent overheating.

1. Check pump for proper priming and lubrication.
2. If unit is equipped with mechanical seal cooling lines, turn on mechanical seal cooling water.
3. Fully open the suction valve and partially open the discharge valve.
4. Start the pumping unit in accordance with the directions on the electrical power supply.
5. Slowly open the discharge valve and adjust pressure and flow to the appropriate operating conditions. Refer to pump nameplate and system operating procedures for design point condition.

**D. OPERATING CHECKS.**

1. Check for undue vibration or noise. If any occurs and does not stop within a short period of time, turn off the pump. For determination of the cause and its remedy refer to troubleshooting in Section VII or consult Carver Pump Company.
2. Check and record pressure readings. The pressure readings should be within the operating system guidelines and similar to number stamped on the pump nameplate.
3. Check and record bearing temperature. It should not exceed 180 degrees F.
4. Check and record power input to the motor.
5. Check for leakage at mechanical seals.

**E. STOPPING THE PUMP.**

1. If the pump is being stopped for overhaul, slowly close the discharge valve. Otherwise leave discharge valves set at condition.
2. Stop the pumping unit in accordance with the directions on the electrical power supply.
3. Tagout and lockout power to motor according to OSHA Standard 1910.147.
4. Close suction valves and any auxiliary fluid lines.
5. The pumping unit is now off.

**F. EMERGENCY SHUTDOWN.**

1. Stop the pumping unit in accordance with the directions on the motor electric power supply.
2. If there is a loss of fluid to the pump, shutdown the pump in accordance with the shutdown procedure in Section VI, Paragraph E.
3. Isolate and correct the problem in accordance with Troubleshooting Operating Problems, Section VII, Table 1.

**G. INDEFINITE SHUTDOWN.**

Lubricate motor bearings per motor manufacturer manual. Provide pump assembly with a protective cover. Drain casing (1) by removing pipe plug (550) in bottom of casing. If necessary, flush pump to remove corrosive or toxic pumpage. Reinstall pipe plug in casing when fluid is completely drained. Drain all piping if there is a possibility of liquid freezing.

**VII. TROUBLESHOOTING OPERATING PROBLEMS.**

If you have followed the installation and starting procedures outlined in this manual, the pump should provide reliable service and long life. However, if operating problems do occur; significant time and expense can be saved if you refer to Table 1 to eliminate the most common causes of those problems.

For the motor troubleshooting refer to the motor manual.

**Table 1. Pumping Unit Troubleshooting**

<b>SYMPTOM</b>	<b>PROBABLE CAUSE</b>	<b>CORRECTIVE ACTION</b>
Failure to deliver liquid.	<ol style="list-style-type: none"> <li>1. System head greater than anticipated.</li> <li>2. Pump not primed.</li> <li>3. Check valve stuck or improperly installed.</li> <li>4. Impeller or suction clogged.</li> </ol>	<ol style="list-style-type: none"> <li>1. Check pump rating against actual head condition.</li> <li>2. Prime pump in accordance with Section VI, Paragraph B.</li> <li>3. Adjust and/or reverse valve.</li> <li>4. Inspect suction and impeller. Clean as necessary.</li> </ol>
Excessive power consumption.	<ol style="list-style-type: none"> <li>1. System head lower than anticipated</li> <li>2. Specific gravity or viscosity of fluid is too high.</li> <li>3. Mechanical defects such as binding rotating elements.</li> <li>4. System head lower than anticipated design condition.</li> <li>5. Incorrect impeller diameter.</li> </ol>	<ol style="list-style-type: none"> <li>1. Adjust pressure flow.</li> <li>2. Check oil temperature and adjust as necessary.</li> <li>3. Check for excessive pipe strain. Check foundation bolting. Replace defective parts.</li> <li>4. Adjust system head. Trim impellers to actual condition.</li> <li>5. Replace impeller or trim impeller to correct diameter. Consult with Carver Pump Company before trimming impellers.</li> </ol>
Insufficient discharge or flow.	<ol style="list-style-type: none"> <li>1. Discharge head greater than anticipated.</li> <li>2. Air or gases in fluid.</li> <li>3. Impeller or suction partially clogged.</li> <li>4. Wrong direction of rotation.</li> <li>5. Specific gravity or viscosity of fluid is too high.</li> <li>6. Incorrect impeller diameter.</li> </ol>	<ol style="list-style-type: none"> <li>1. Check pump rating against actual head condition.</li> <li>2. Adjust and/or redesign suction system. Add fluid to system. Check for air leaks in suction.</li> <li>3. Inspect strainer and impeller and clean as necessary.</li> <li>4. Reverse direction of rotation.</li> <li>5. Check oil temperature and adjust as necessary.</li> <li>6. Replace impeller or trim impeller to correct diameter. Consult with Carver Pump Company before trimming impeller.</li> </ol>
Excessive leakage around mechanical seal housing.	<ol style="list-style-type: none"> <li>1. Faulty mechanical seal.</li> </ol>	<ol style="list-style-type: none"> <li>1. Replace mechanical seal in accordance with procedures in Section IX, Service and Repair.</li> </ol>
Vibration excessive.	<ol style="list-style-type: none"> <li>1. Foundation bolting loose.</li> <li>2. Impeller partially blocked.</li> <li>3. Wrong rotation.</li> <li>4. Insufficient foundation.</li> <li>5. Pipe strain.</li> <li>6. Motor improperly balanced.</li> </ol>	<ol style="list-style-type: none"> <li>1. Torque bolting to proper values.</li> <li>2. Inspect impeller and clean as necessary.</li> <li>3. Adjust direction of rotation.</li> <li>4. Stiffen foundation as necessary.</li> <li>5. Modify piping as necessary.</li> <li>6. Balance motor.</li> </ol>

## VIII. MAINTENANCE.

Generally, the pump does not need continuous supervision. The pump should always run quietly and smoothly, without vibration. To ensure such operation, the following maintenance schedule should be applied at regular intervals during operation of the pump. Occasional visual checks are recommended. Data should be recorded periodically for each pump to keep track of maintenance which has been performed and to note operational problems. A sample maintenance record sheet is provided for this purpose at the front of this manual.

### Daily Inspection:

- Visually inspect unit.
- Check for leakage at mechanical seals.

### Weekly Inspection:

- Check power (amps) readings.
- Check pump discharge pressure. Prescribed operating discharge pressure should never drop below 90 percent of design point pressure.
- Check vibration on pump and motor bearings. Vibration should NOT exceed 1.5 of overall displacement (unfiltered) peak to peak mils (0.001") at 3550 RPM and 3.0 of overall displacement (unfiltered) peak to peak mils (0.001") at 1750 RPM.

### Monthly Inspection:

- Check foundation bolts.

### Semi-annual Inspection:

- If stand-by pumps are installed, it is advisable to operate pumps on a rotational system to give each pump a periodic duty. This ensures that stand-by pumps will have periodic operation and always be in good condition for instant start-up.

### 25000 Hours - Overhaul

- For pump overhaul, complete Section IX, Service and Repair.

**A. LUBRICATION OF MOTOR BEARINGS.** See motor manufacturer's instructions to be sure motor bearings are properly lubricated.

**B. TORQUE VALUES.** Refer to Table 2, Recommended Torque Values. Clean and properly lubricate threads and bearing face of the fastener to obtain the proper fastener loading from these torque values. Fasteners should be tightened evenly and in stages.

**Table 2. Recommended Torque Values**

Fastener Size	Torque Value by Fastener Material (Maximum) (ft-lbs)	
	Steel Gr 2	316 SS
<b>3/8-16 UNC</b>	15	18
<b>1/2-13 UNC</b>	37	38
<b>5/8-11 UNC</b>	73	82
<b>3/4-10 UNC</b>	129	111
<b>7/8-9 UNC</b>	125	172
<b>1-8 UNC</b>	187	254

**Table 2. Recommended Equipment**

Tools	Materials	Test Equipment
Spanner	O-ring	Volt-Amp Meter
Wrench	Lubricant	Calipers
Rawhide or	Dow 111	Micrometer (ID
Wood Mallet	Loctite 242	and OD)
Wooden	Rust Solvent	Flow Meter
Wedge	Anti-Seize	
Allen Wrench	Loctite 414	
Set	Cyanoacrylate	
Socket, Open,	Super Glue	
& Box		
Wrench Set		
Vice Grips		
Torque Wrench		
Bearing Heater		
Bearing Puller		

## IX. SERVICE AND REPAIR.

During disassembly, reference the exploded view, Figure 3, for the Parts List that corresponds to the part numbers used in this manual. Refer to Paragraph C for parts inspection. Refer to Table 7 for recommended spare parts.

**A. PREPARATIONS FOR DISASSEMBLY OF PUMP.**

During disassembly, match mark parts so they can be replaced in their original position. All parts should be thoroughly cleaned or replaced with new, if necessary. Sealing faces should be perfectly clean.

**CAUTION**

Factory authorized parts must be used to safely maintain your Carver Pump.

**NOTE**

To avoid damage to O-rings, check to make sure all parts are free of sharp edges or burrs.

Close suction and/or discharge valves. The pump casing should be cooled down to ambient temperature. The casing must be empty and not under pressure.

After prolonged operation, components may not be easily removed from shaft. In such instances, rust solvent may be used and suitable extracting tools applied wherever possible. DO NOT use force under any circumstances. Refer to Table 3, Recommended Equipment, for proper tooling during disassembly and assembly. Refer to appropriate sectional drawing for location of parts followed by an item number. Assemble the pump in accordance with accepted rules of engineering practice. Coat individual components with a suitable lubricant before assembling. Assembly of unit should be performed on a clean, flat surface.

**NOTE**

While assembling the pumping unit, Carver Pump Company recommends that the following parts be replaced with new:

- O-rings / gaskets
- Shims
- Locknuts / Lockwashers
- Grease seals
- Mechanical seals

Prepare the pumping unit for disassembly using the following list:

1. Read this entire section and study the exploded view or sectional for your specific drawing, before disassembling the pump.

**DANGER**

Before attempting to disassemble the pump, the electrical power supply to the motor must be locked out and tagged in the "OFF" position to prevent injury or death to personnel servicing the pumping unit.

2. Stop the pumping unit; refer to Section VI, Paragraph E.
3. Confirm discharge valves are closed.
4. Remove terminal box cover. Disconnect motor leads. Reconnect terminal box cover.

**DANGER**

Be sure to adequately support the piping prior to disconnecting the pumping unit. Failure to adequately support the piping could result in serious injury or death to personnel and/or damage to the pumping unit.

**CAUTION**

Properly decontaminate pump and piping before disconnecting the pumping unit. Applicable hazardous material procedures must be followed.

5. Shut off and close all valves controlling flow of liquid to and from pump. Disconnect piping and gauge line as necessary.
6. Drain casing (1) by removing pipe plug (550). If necessary, flush pump to remove corrosive or toxic pumpage. Reinstall pipe plug in casing when fluid is completely drained.

**B. DISASSEMBLY OF PUMP.** The instructions that follow are an aid for properly trained personnel to service your Carver Pump. These instructions refer to Figures 3 or 4 and Table 6. If a specific sectional assembly drawing exists for a pumping unit, then that drawing should be referred to for service work. Read this entire section and study Figures 3 or 4 and Table 6 before disassembling the pump.

The back pull-out design of the GHJM Close-Coupled Pump enables the pump to be disassembled without disconnecting the piping or removing the pump casing.

After completion of dismantling, all parts should be thoroughly cleaned or replaced by new ones if necessary. All gaskets and sealing faces should be

perfectly clean. When cutting new gaskets, make sure they are the same thickness as the old ones.

#### NOTE

Mark or number each component while dismantling according to sequence.

1. Assure Section IX, Paragraph A has been reviewed before continuing with disassembly.
2. Remove bolts (800B) attaching the adaptor (71) to the casing (1).



#### **WARNING**

Use a hoist with adequate lifting capacity; refer to Section V, Paragraph B.

When handling the motor with mounted impeller, do not exceed the rated capacity of the hoisting equipment.

3. Support the casing (1) and suction cover (9). Attach hoisting straps to lifting lugs on motor (200) and through the adaptor (71) to distribute weight evenly and support the motor during disassembly.



#### **CAUTION**

When removing motor/adaptor/impeller assembly slowly pull straight back. Do not lift motor more than is necessary to pull straight back.

4. Carefully remove the motor/adaptor/impeller assembly straight back from the casing (1) and move it to a suitable work area. Transfer pumping unit back pull-out assembly to a suitable work area with access to a machine shop.



#### **CAUTION**

Any debris caught in the pump passageway will be drawn into the pumping unit, causing damage, and cause the pumping unit to be out of balance causing vibration.

5. The casing (1) and suction cover (9) will remain assembled with the piping if only back pull-out assembly was removed. Ensure that no foreign matter such as dirt, chips, tools, etc. are caught

in the piping or casing (1) as this debris will be drawn into the pump and cause extensive damage.

6. Remove O-ring (700A) from adaptor (71).

#### NOTE

The spring holder from the mechanical seal (90) may remain attached to the impeller (2 or 3), unless necessary to remove it.

#### NOTE

Impeller capscrew (24) has right-handed threads.

Impeller washer gasket is a multi-piece gasket.

7. Remove impeller capscrew (24), impeller washer (28), impeller washer gasket (73C), impeller capscrew O-ring (700C) and impeller (2 or 3) from motor (200) shaft. Remove impeller key (32).
8. Remove sleeve gasket (73A).

#### NOTE

DO NOT remove rotating element of mechanical seal (90) from shaft sleeve (14) at this point, especially if mechanical seal is relatively clean and in good working condition. If removed from the sleeve Carver Pump Company recommends the mechanical seal be replaced.

9. Remove shaft sleeve (14) with rotating elements of mechanical seal (90) from motor (200) shaft. If mechanical seal is to be replaced, remove rotating elements of mechanical seal from shaft sleeve.
10. Remove O-ring (700D) from motor (200) shaft.
11. Remove bolts (800C). Remove adaptor (71) from motor (200).
12. Remove stationary element of mechanical seal (90) from adaptor (71).
13. If necessary, remove slinger (40) from motor (200) shaft.

### **C. PARTS INSPECTION.**

1. All parts should be thoroughly cleaned with a suitable solvent or replaced with new ones if necessary. All sealing faces should be perfectly clean. It is recommended that all gaskets, O-rings, grease seals, lip seals, and locking

- devices with a nylock feature, such as locknuts, be replaced with new if removed from position.
2. Check shaft for runout, scratches, grooves, or any possible damage. Touch up scratches and grooves with a polishing cloth and inspect for remaining grooves or deep scratches. A bent or excessively damaged shaft should be replaced. Refer to motor manual for further information.
  3. Inspect casing for pitting, scoring, and erosion. The inside of the casing should be free of any pits or grooves. Replace the casing if any of these defects are present.
  4. Inspect mechanical seal. Repair or replace mechanical seal that are extremely worn or damaged.
  5. Inspect impeller key for distortion and push fit into keyway. The key should be square on all four edges. They should fit without having to be forced. The key should not rock in keyway. Replace key or shaft if necessary.
  6. Inspect tubing for kinking. Replace kinked tubing.
  7. If the impeller shows excessive wear due to erosion or pitting, so that performance cannot be restored, it must be replaced. If a new impeller is installed, check to make sure that it is balanced and of the correct trim diameter.
  8. Check the wearing surface clearance of the impeller as follows:
    - a. Measure Outside Diameter (OD) of front impeller hub (2) in three places.
    - b. Measure Inside Diameter (ID) of wearing surface of suction cover (9) in three places.
    - c. If difference between the high reading of the ID of the wearing surface of suction cover (9) and the low reading of the OD of the impeller (2) hub exceeds double the maximum clearances given in Table 4, replace the suction cover (9).
    - d. Measure OD of back impeller hub (2 or 3) in three places.
    - e. Measure ID of wearing surface of the adaptor (71) in three places.
    - f. If difference between the high reading of the ID of the wearing surface of the adaptor (71) and the low reading of the OD of the impeller (2 or 3) hub exceeds double the maximum clearances given in Table 4, replace the adaptor (71).

**Table 4. Factory Wear Diametrical Clearance (Inches)  
(If not otherwise stated on sectional assembly in Appendix A.)**

Pump Size	Shaft Extension	Front Wear Clearance (Inches)	Back Wear Clearance (Inches)*
1.25 x 1 x 5	JM	.016/.020	N/A
2 x 1.5 x 5	JM	.016/.020	N/A
2.5 x 2 x 5	JM	.016/.020	N/A
1-1/4 X 1 X 7	JM	.016/.020	N/A
1-1/2 X 1-1/4 X 7	JM	.016/.020	N/A
2-1/2 X 2 X 7	JM	.012/.016	N/A
3 X 2-1/2 X 7	JM	.012/.016	N/A
4 X 3 X 7	JM	.014/.018	.014/.018
5 X 4 X 7	JM	.014/.020	.012/.016
1-1/2 X 1-1/4 X 10	JM	.014/.020	N/A
2 X 1-1/2 X 10	JM	.018/.020	N/A
2-1/2 X 2 X 10	JM	.008/.016	.008/.016
3 X 2-1/2 X 10	JM	.016/.020	.016/.020
4 X 3 X 10	JM	.010/.016	.010/.016
5 X 4 X 10	JM	.016/.020	.016/.020
6 X 4 X 10	JM	.016/.020	.016/.020
6 X 5 X 10	JM	.023/.025	.021/.026

\*If impeller has back wear ring.

**D. REASSEMBLY OF PUMP.** During reassembly, install parts in accordance with instructions. These instructions refer to Figures 3 or 4 and Table 6. If a specific sectional assembly drawing exists for a pumping unit that drawing takes precedence and should be referred to for service work. Read this entire section and study Figures 3 or 4 and Table 6 before reassembling the pump.



**CAUTION**

During reassembly, install new O-rings, gaskets and mechanical seal if removed from position. O-rings, gaskets, and the mechanical seal may have been damaged during disassembly.

**NOTE**

All parts should be thoroughly cleaned or replaced with new ones if worn or damaged. All

sealing faces should be perfectly clean, but do not scratch or alter surface finish on seal faces.

1. Complete Section IX, Paragraph C before continuing with reassembly.
2. If removed, install slinger (40) on motor (200) shaft.

**NOTE**

Refer to mechanical seal vendor instructions for proper mechanical seal installation procedure.

3. Lubricate O-ring on stationary element of mechanical seal (90). Install stationary element of mechanical seal into adaptor (71).
4. Secure adaptor (71) to motor (200) with bolts (800C).
5. Lubricate outside of the shaft sleeve (14) to facilitate the axial positioning of mechanical seal (90). Install rotating element of mechanical seal on the shaft sleeve. Clean and dry seal faces.

6. Install O-ring (700D) to step on motor (200) shaft.
7. Lubricate outside of the motor (200) shaft with Dow 111. Install shaft sleeve (14) with rotating element of mechanical seal (90) assembly onto motor shaft. Install sleeve gasket (73A).
8. If removed, glue spring holder of mechanical seal (90) to impeller (2 or 3) hub as follows:

**NOTE**

The tool used to assure proper centering of the spring holder is a bar with two diameters, the OD of the shaft sleeve and the OD of the motor shaft at the impeller. Special tool, part number can be found in Table 5. This tool is optional to help facilitate in installation of spring holder.

- a. Insert tool into impeller hub.



**CAUTION**

Keep fingers away from glue to avoid injury to personnel or parts.

- b. Apply 4-6 droplets of glue (Loctite 414 Cyanoacrylate Super Glue) around impeller side of spring holder.
- c. Slip spring holder over tool and press onto impeller hub. Allow glue to set.
- d. Remove the tool from impeller bore.

**Table 5. Seal Retainer Tool Parts List**

Impeller Bore Size (Inches)	Description	Part Number
7/8	Tool/Seal Retainer GHJM Seal Installation	250-1100101-801
1-1/4	Tool/Seal Retainer GHJM Seal Installation	250-1100102-801

**Enclosed Impeller Only**

**NOTE**

On pumps equipped with a semi-open impeller, omit steps 9 through 13. Steps 9 through 13 are procedures that describe impeller clearance adjustment for enclosed impellers only. Refer to Figure 3 for enclosed impeller exploded view.

Impeller capscrew (24) has right-handed threads.

Impeller washer gasket (73C) is a multi-piece gasket to allow for various thicknesses to compensate for tolerance stack-up. Add or subtract to gasket thickness to obtain .010" to .030" gasket protuberance from impeller washer (28) face on the impeller (2), when impeller is completely seated against the shaft sleeve (14). This will assure proper gasket compression and proper tension to properly locate the impeller on the shaft.

9. Install impeller key (32), into motor (200) shaft keyway. Install mechanical seal spring in spring holder. Align impeller (2) with impeller key and spring with mechanical seal (90), and then slowly slide impeller straight on motor shaft. Install impeller washer gasket (73C), impeller washer (28), and O-ring (700C). Secure impeller with impeller capscrew (24). Torque impeller capscrew as required.
10. Install O-ring (700A) on adaptor (71).
11. Rotate the motor (200) shaft by hand to ensure it rotates freely and no rubbing noises are present.
12. Return rotor assembly to pump location.



**CAUTION**

When installing motor/adaptor/Impeller assembly slowly push assembly straight into casing. Do not lift motor more than is necessary to push assembly straight in.

13. Install motor/adaptor/Impeller assembly into casing (1), being careful not to damage impeller (2). Secure casing (1) to adaptor (71) with bolts (800B).

**Semi-open Impeller Only****NOTE**

On pumps equipped with a closed impeller, omit steps 14 through 20d. Steps 14 through 20d are procedures that describe impeller clearance adjustment for semi-open impellers only. Refer to Figure 4 for semi-open impeller exploded view.

**CAUTION**

During steps 17 through 20d, use old impeller capscrew (24) to secure impeller (3). Once proper impeller clearance is achieved, use a new impeller capscrew to secure impeller.

During assembly, install new impeller capscrew (24) with locktite.

**NOTE**

Impeller gasket installation is critical to Dry Shaft design. Insufficient gasket thickness may allow liquid to access the end of the shaft. Excessive gasket thickness may allow liquid ingress to shaft area behind the impeller.

14. Install impeller key (32). Install mechanical seal (90) spring in spring holder. Coat impeller (3) bore with DOW 111. Align impeller (3) with impeller key and spring with mechanical seal, and then slowly slide impeller straight on motor shaft. and install impeller. Install impeller washer gasket(s) (73C) in impeller bore over the end of the motor (200) shaft, combining thicknesses and quantities, as required, so the outer most gasket face protrudes from the impeller bore by approximately .02 to .04 inches when the impeller/sleeve/gasket are lightly compressed. Install impeller capscrew O-ring (700C) and impeller washer (28) on impeller capscrew (24). Install and properly torque impeller capscrew as required.
15. Install O-ring (700A) on adaptor (71).

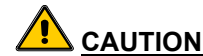
**CAUTION**

When installing motor/adaptor/Impeller assembly slowly push assembly straight into casing. Do not lift motor more than is necessary to push assembly straight in.

16. Install motor/adaptor/Impeller assembly into casing (1), being careful not to damage impeller (2). Secure casing to adaptor (71) with bolts (800B).
17. Using appropriate leveling tools, level casing (1). Torque bolts (800B) and (800C), refer to Table 5.
18. Install suction cover (9) to casing (1). DO NOT install suction cover gasket (73B).
19. There must be a clearance of 0.010 inches minimum and 0.020 inches maximum between open impeller (3) and suction cover (9). To check clearance, rotate shaft by hand and listen for any rubbing noise.
20. If rubbing noises are present, the clearance between impeller and suction cover is less than 0.010 inches. To remedy this:
  - a. Remove bolts (800A) and suction cover (9).
  - b. Install new suction cover gasket (73A) on suction cover (9).
  - c. Install suction cover (9), securing with bolts (800B).
  - d. Recheck the clearance and repeat the above steps as necessary to correct the clearance between the impeller (3) and the suction cover (9) and there is no more rubbing. The maximum number of suction cover gaskets (73B) to be used is 5. Consult with the factory if more than 5 are needed.
21. Rotate the motor (200) shaft by hand, if accessible, to ensure it rotates freely and no rubbing noises are present.
22. If removed, install suction cover (9) on casing (1) and secure with bolts (800A).
23. Reinstall pipe plug (550) in casing (1).
24. Secure motor (200) feet to base.
25. Connect auxiliary piping.
26. Remove all tags from valves and switches. Open system valves. Reconnect power supply to motor, refer to the motor manual.
27. Start pumping unit in accordance with Section VI, Paragraphs A, B, C, and D.

**E. MOTOR.** The motor should be maintained in accordance with the manufacturer's instructions.

## X. PARTS LISTS.

This section contains Table 7 that notes the recommended spare parts for these pumping units. Refer to the sectional assembly drawing specific to your unit for the actual part numbers and recommended spare parts.

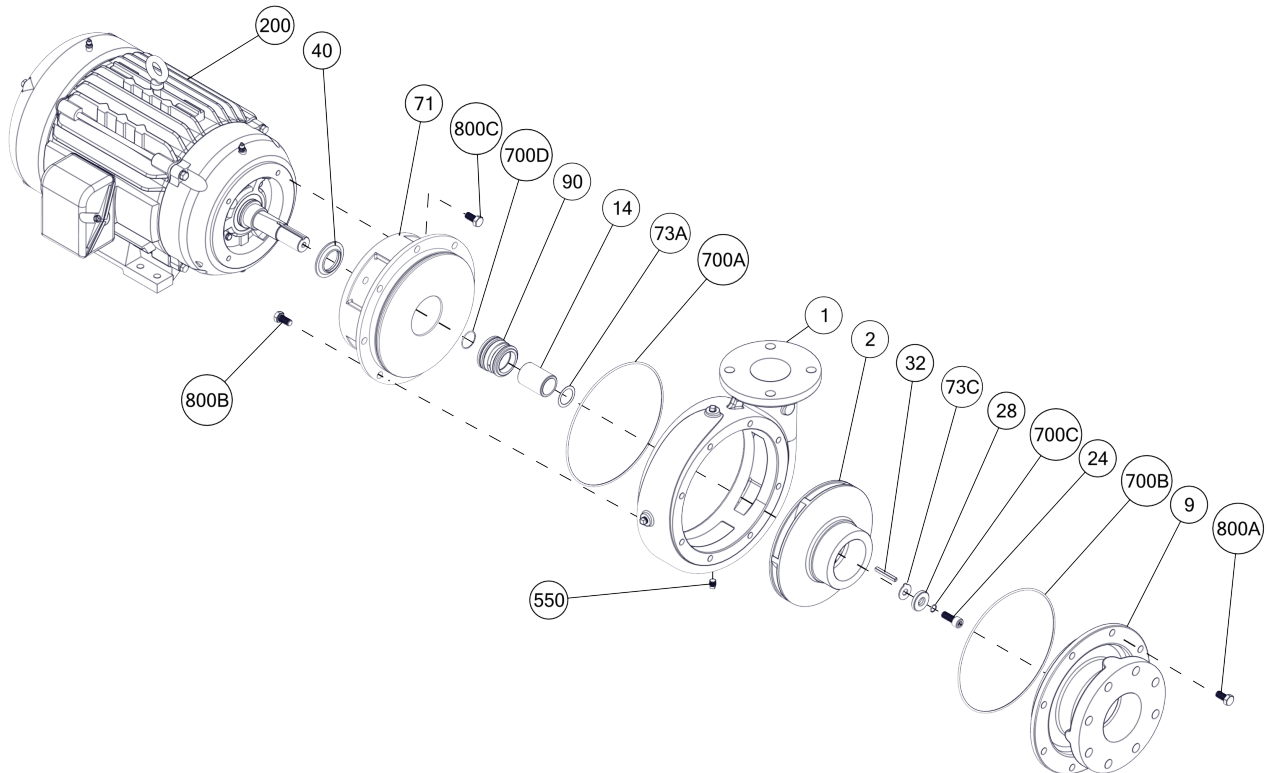

**Figure 3. Reference Exploded View, Enclosed Impeller**

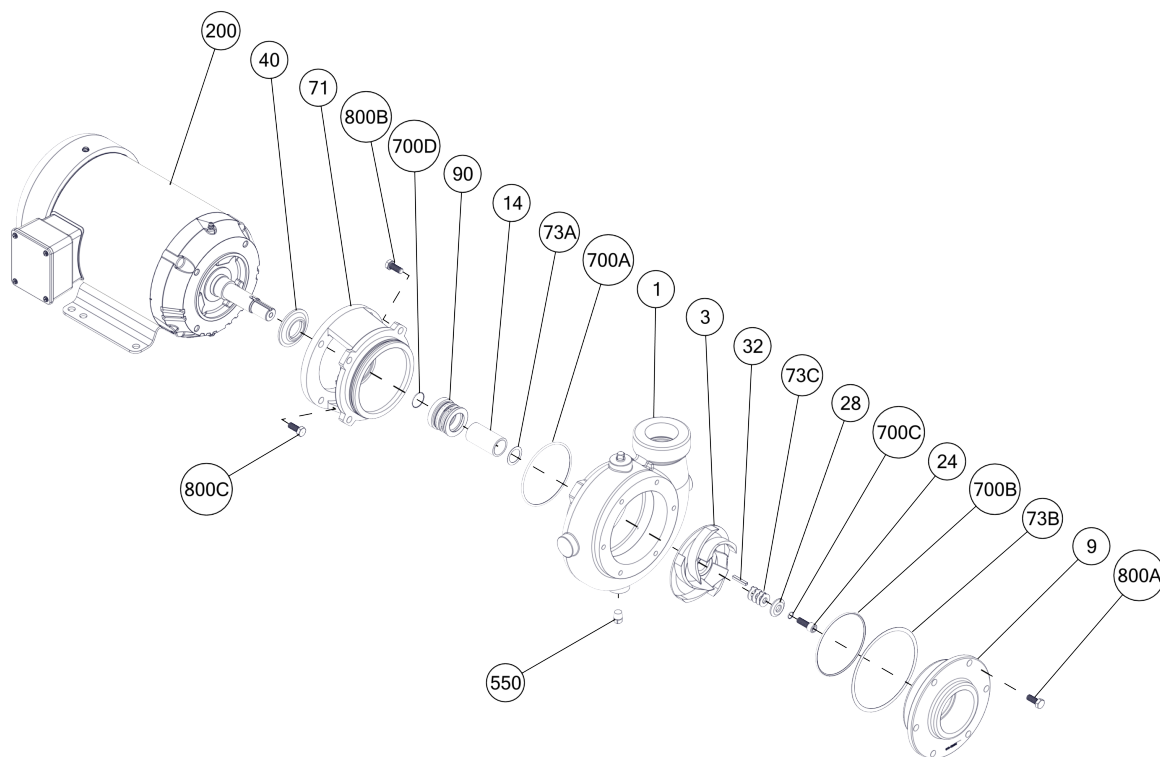

**Figure 4. Reference Exploded View, Semi-Open Impeller**

**Table 6. Parts List**

Item Number	Description	Item Number	Description
1	Casing	200	Electric Motor
2	Impeller, Enclosed	*226	Nameplate
3	Impeller, Semi-Open	*226X	Rotation Plate
9	Suction Cover	550	Pipe Plug, Casing
14	Shaft Sleeve	550A	Pipe Plug, Adaptor
24	Capscrew – Impeller	700A	O-ring – Adaptor
28	Washer – Impeller	700B	O-ring – Suction Cover
32	Key – Impeller	700C	O-ring – Impeller Capscrew
40	Slinger	700D	O-ring – Shaft Sleeve
71	Adaptor	800A	Bolt – Suction Cover/Casing
73A	Gasket – Sleeve	800B	Bolt – Adaptor/Casing
73B	Gasket – Suction Cover	800C	Bolt – Adaptor/Motor
73C	Gasket – Impeller Washer	*888	Drivescrew - Nameplates
90	Mechanical Seal		

\*Items not shown on exploded view

**Table 7. Recommended Spare Parts List**

<b>Item</b>	<b>Description</b>	<b>Item</b>	<b>Description</b>
2	Impeller, Enclosed	73B	Gasket – Suction Cover
3	Impeller, Semi-Open	73C	Gasket – Impeller Washer
14	Shaft Sleeve	90	Mechanical Seal
24	Capscrew – Impeller	700A	O-ring – Adaptor
28	Washer – Impeller	700B	O-ring – Suction Cover
32	Key – Impeller	700C	O-ring – Impeller Capscrew
73A	Gasket – Sleeve	700D	O-ring – Shaft Sleeve

This page intentionally left blank.



**CARVER PUMP™**  
**Built for purpose**

2415 Park Avenue, Muscatine, IA 52761  
Phone: 563.263.3410 [www.carverpump.com](http://www.carverpump.com)

**GHJM Close-Coupled Pump IOM**  
**100 – 19.01.EN**