



The KWP is our solids-handling pump for water, oils, and chemicals in process and general industry applications.

The KWP is designed for fluids with entrained solids and fibrous materials up to 1.5" in diameter. Wide passages in the two-vane enclosed impeller minimize clogging and crushing of the entrained material. Primarily a horizontal unit, the KWP can be either frame mounted or close coupled.

Common options include soft packing, single or double cartridge seals, and any type of seal flush plan. The back pull out design makes maintenance easy and lower total life cycle cost. Shaft deflections are limited to 0.002" at the seal.

All together, these features combine to make the KWP a pump of exceptional value, combining affordability with some of the most efficient hydraulics found in a pump of this type.



Quality Management System Approval Certification Number 95-370h

STANDARD MATERIALS

Casing	Cast Iron or 316 SS
Impeller	Cast Iron or 316 SS
Shaft Sleeve	316 SS
Shaft	Carbon Steel
Wear Rings	17-4PH SS
Mechanical Seal	Carbon on Ceramic or Silicon Carbide Faces
Other materials of construction available upon request.	

MECHANICAL DATA

Configuration	Frame Mounted or Close Coupled with JM Shaft
Extension	
Input Power	Up To 50 HP
Connections	Class 150 ANSI Flanges



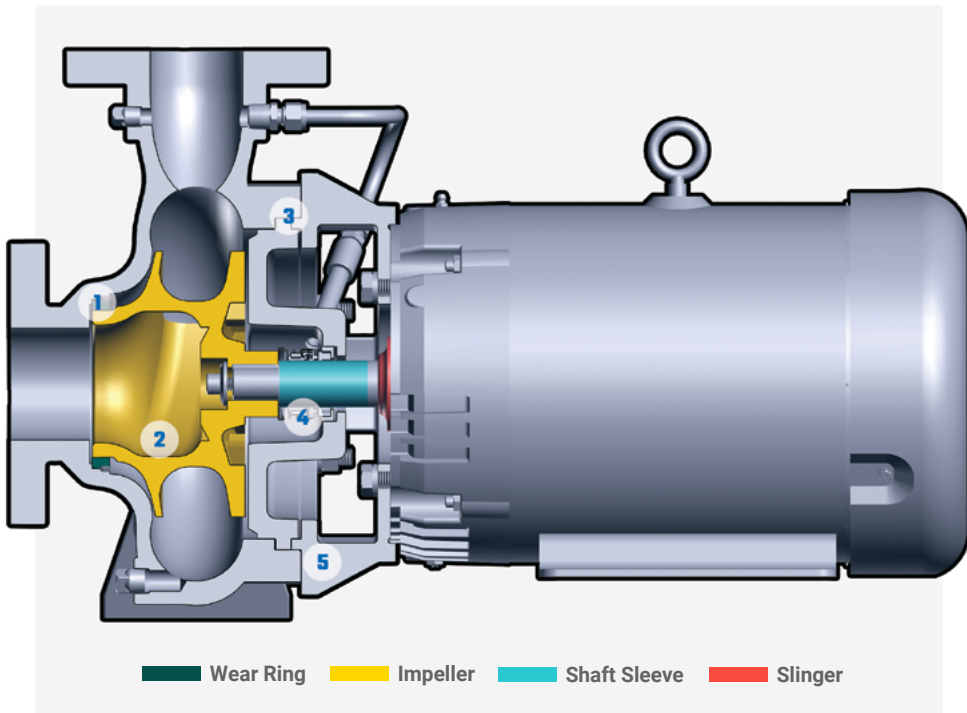

- 1 WEAR RINGS**
Replaceable wear ring
- 2 IMPELLERS**
Wide passages to minimize clogging and crushing of the entrained material
- 3 360° REGISTERED FITS**
Fully confined gaskets assure proper sealing and alignment of critical fits
- 4 MECHANICAL SEAL**
Single mechanical seal on close coupled units
- 5 BACK PULL OUT DESIGN**
Allows inspection of rotating elements without disturbing the piping

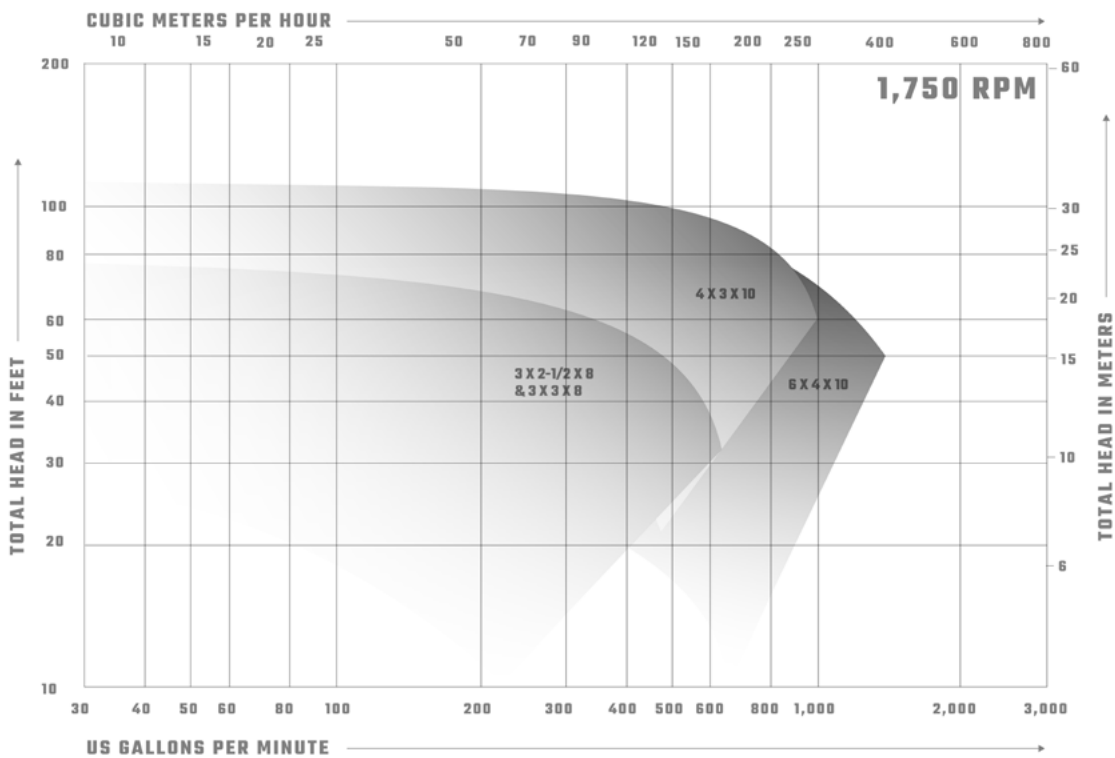

HYDRAULICS

- Flows to 1,300 US GPM (300 m³/hr)
- Heads to 240 feet (100 m)
- Solids to 1-1/2 in. (38 mm) Diameter
- Temperatures from 250° F (120° C)
- Speeds to 3,550 RPM

APPLICATIONS

- Commercial
- Desalination/Municipal
- Industrial
- Power Generation
- Coating, Surface Treatment and Spray Paint Systems
- And other applications

Contact us

2415 Park Avenue
Muscatine, Iowa 52761
USA

(563) 263-3410
sales@carverpump.com
www.carverpump.com