

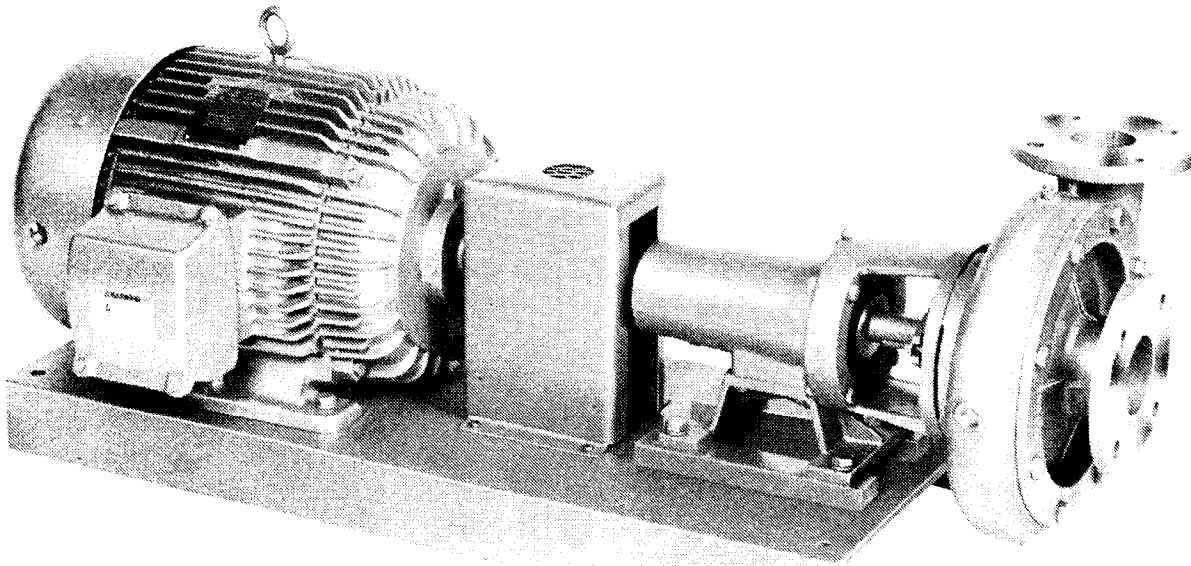

Instruction I-160

Creating Value.

INSTALLATION, OPERATION, AND MAINTENANCE INSTRUCTIONS L & H HORIZONTAL PUMP

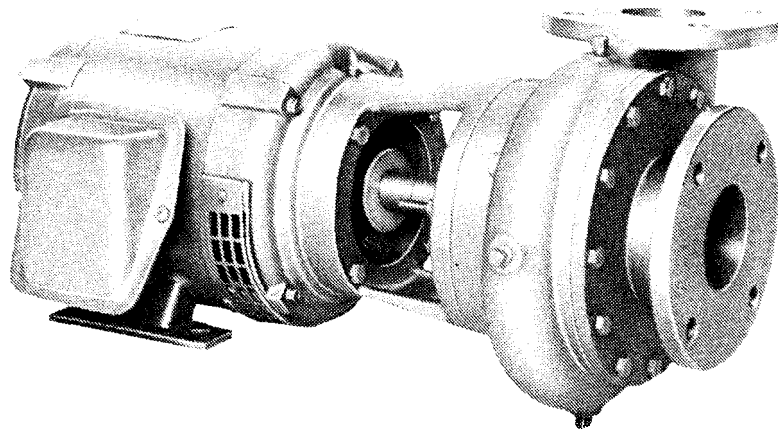

PREFACE: The instructions contained in this manual apply to Carver Pump Company L & H horizontal end suction pumps of close coupled or frame mounted models with capacities to 2,500 GPM, heads to 370 feet and temperatures to 250 degrees F. They are designed for use with standard NEMA motors in industrial, commercial, chemical, and pollution control applications. For ease of maintenance, the packing and the mechanical seal are field interchangeable. All wetted surfaces are available in bronze fitted, all iron, 316 stainless, or all bronze construction.

TABLE OF CONTENTS

Section/Paragraph	Page	Section/Paragraph	Page
I. GENERAL DESCRIPTION AND SAFETY		D. Loss of Suction During Operation	5
PRECAUTIONS	1	E. Too Much Stuffing Box Leakage	5
A. Pump Identification	1	F. Vibration or Noise	5
B. Nameplate	1	G. Overheating	5
C. Safety Precautions	1	H. Speed Too Low	5
II. INSPECTION AND STORAGE	1	VI. MAINTENANCE	5
A. Inspection	1	A. Field Inspection	5
B. Storage of Pump	1	B. Grease Lubrication of Pump Bearings	6
III. INSTALLATION	2	C. Lubrication of Driver	6
A. Location	2	D. Stuffing Box with Packing	6
B. Handling	2	E. Seal Connection	7
C. Foundation	2	F. Mechanical Seal	7
D. Leveling of Unit	2	VII. SERVICE AND REPAIR	8
E. Coupling Alignment	2	A. Preparations for Disassembly of Pump	8
F. Direction of Rotation	2	B. Disassembly of Frame Mounted or Close Coupled Pump	8
G. Coupling Guard	3	C. Disassembly of Power Frame on Frame Mounted Pump	8
H. Grouting	3	D. Parts Inspection	8
I. Piping	3	E. Assembly of Frame Mounted or Close Coupled Pump with a Packed Stuffing Box and Semi-Open Impeller	9
J. Auxiliary Piping Connections and Gauges	3	F. Assembly of Frame Mounted or Close Coupled Pump with Mechanical Seal and Semi-Open Impeller	10
K. Motor	3	G. Assembly of Frame Mounted or Close Coupled Pump with Enclosed Impeller	11
IV. OPERATION	4	H. Replacement of Wear Ring on Pump Equipped with Enclosed Impeller	11
A. Prestart Cautions	4	I. Parts Inventory Guide	12
B. Priming	4	J. Parts Ordering	12
C. Starting the Pump	4	VIII. PARTS LISTS AND EXPLODED VIEW DRAWINGS	12
D. Operating Checks	4	IX. PUMP SERVICE RECORD	16
E. Stopping the Pump	4		
F. Indefinite Shutdown	4		
V. TROUBLESHOOTING OPERATING PROBLEMS	5		
A. No Discharge	5		
B. Excessive Power Consumption	5		
C. Insufficient Discharge Pressure or Flow	5		

LIST OF TABLES

Number	Title	Page	Number	Title	Page
1.	Packing Requirements	7	5.	Parts List for Frame Mounted L & H Horizontal Pump	13
2.	Wear Ring Clearance	9	6.	Parts List for Close Coupled L & H Horizontal Pump	13
3.	Impeller and Wear Ring Matching Materials	11			
4.	Recommended Spare Parts	12			

LIST OF ILLUSTRATIONS

Number	Title	Page	Number	Title	Page
1.	Coupling Alignment	3	3.	Exploded View for Close Coupled L & H Horizontal Pump	15
2.	Exploded View for Frame Mounted L & H Horizontal Pump	14			

I. GENERAL DESCRIPTION AND SAFETY PRECAUTIONS.

A. PUMP IDENTIFICATION. Use the following example for identifying information about your pump model number.

1-1/4 x 1 x 6LA

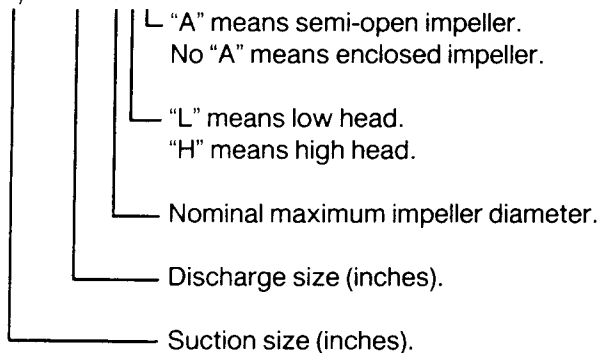

B. NAMEPLATE. A nameplate is attached to each pump. The data on the nameplate should be recorded and filed for easy reference. Nameplate data should be furnished to Carver Pump Company or its representative when ordering spare parts or requesting information. The serial number of the pump is also stamped on the circumference of the suction flange.

C. SAFETY PRECAUTIONS. This manual contains descriptions and instructions which are the result of carefully conducted engineering and research efforts. The manual is designed to provide adequate instructions for the safe and efficient installation, operation, or maintenance of the pump. Failure or neglect to properly install, operate, or maintain the pump may result in personal injury, property damage, or unnecessary damage to the pump.

Variations exist in both the equipment used with these pumps and in particular installation of the pump and driver. Therefore, specific operating instructions are not within the scope of this manual. This manual contains general rules for installation, operation, and maintenance of the pump.

Observe all caution or danger tags attached to the equipment or included in this manual.

CAUTION IMPORTANT SAFETY NOTICE

Installation, use, and operation of pumping equipment is affected by various federal, state, and local laws and the regulations con-

cerning OSHA. Compliance with such laws relating to the proper installation and safe operation of pumping equipment is the responsibility of the equipment owner and all necessary steps should be taken by the owner to assure compliance with such laws before operating the equipment.

II. INSPECTION AND STORAGE.

A. INSPECTION. Upon receipt of the shipment, unpack and inspect the pump, driver assemblies, and individual parts to insure none are missing or damaged. Carefully inspect all boxes and packing material for loose parts before discarding them. Immediately report any missing parts or damage incurred during shipment to the factory and to the transportation company and file your “damaged and/or lost in shipment” claim with the carrier.

B. STORAGE OF PUMP. If the equipment is not to be immediately installed and operated, store it in a clean, dry, well-ventilated place, free from vibrations, moisture, and rapid or wide variations in temperature.

Grease Lubricated Pump. Rotate the shaft for several revolutions at least once every two weeks to coat the bearing with lubricant, retard oxidation and corrosion, and prevent possible false brinelling.

Mechanical Seal Pump. Pour at least 4 ounces of mineral oil into the seal housing and drain the oil just prior to start up.

Consider a unit to be in storage when:

1. It has been delivered to the job site and is waiting to be installed.
2. It has been installed but operation is delayed pending completion of construction.
3. There are long (30 days or more) periods between operation cycles.
4. The plant (or department) is shut down for periods of longer than 30 days.

NOTE

Storage requirements vary depending on climatic environment, length of storage, and equipment. For storage periods of three months or longer, contact manufacturer for specific instructions. Improper storage could damage equipment and would result in non-warranty covered restoration or non-warranty covered product failures.

III. INSTALLATION.

A. LOCATION. The pump should be installed as close to the fluid as possible. A short, direct suction pipe can be used to keep suction losses at a minimum. If possible, locate the pump so fluid will flow by gravity to the suction opening. The discharge piping should be direct with as few elbows and fittings as possible. The total net positive suction head available (NPSHA), which includes the suction lift and pipe friction losses, must be equal to or greater than the net positive suction head required (NPSHR) by the pump.

The pump and driver should be located in an area that will permit periodic inspection and maintenance. Head room and access should be provided and all units should be installed in a dry location with adequate drainage.

B. HANDLING.

CAUTION

Do not pick up the complete unit by the driver or pump shafts or eyebolts.

To lift a horizontal mounted unit, a chain or suitable lifting device should be attached to each corner of base structure. Use a sling for pumps without baseplates. The individual driver may be lifted using proper eyebolts provided by the manufacturer, but these should not be used to lift the assembled unit.

C. FOUNDATION. The foundation should be 3 to 6 inches wider and longer than the baseplate, have a level surface, and be of sufficient mass to prevent vibration and form a permanent rigid support for the unit. The best foundations are concrete with anchor bolts of adequate size embedded in the foundation in pipe sleeves having an inside diameter 2-1/2 times larger than the bolt diameter. This will allow for accurate positioning of the unit. Keep the concrete surface clean, yet rough.

D. LEVELING OF UNIT. Lower unit onto foundation, positioning base structure so anchor bolts are aligned in middle of holes in base. On all frame mounted units, always disconnect the coupling halves and never reconnect them until all alignment operations are complete.

The base should be supported on metal shims or metal wedges placed directly beneath the part of the base supporting the most weight. The shims or wedges should be spaced close enough to give even support and stability.

Adjust metal supports or wedges until suction and discharge flanges are level. On frame mounted pumps, driver and pump shafts need to be in alignment. Alignment and leveling corrections can be accomplished by

adjusting supports under the base. When proper alignment is obtained, tighten foundation bolts snugly, but not too firmly. Recheck alignment before grouting.

CAUTION

Do not attempt to straighten the base by using the anchor bolts.

E. COUPLING ALIGNMENT. On frame mounted pumps, check alignment of pump and driver shafts. Be sure pump and driver shafts can be turned freely by hand. Even if driver is mounted and aligned at the factory, it must be realigned at the site because misalignment can occur during transport and installation. This must be done before grouting the baseplate and connecting the piping.

Standard couplings are Lovejoy Elastomeric Jaw couplings, type AL, with snap-wrap spiders or sox spiders. Literature from the manufacturer can be furnished upon request.

Flexible couplings can only absorb limited misalignment of the shafts. This part must not be used to compensate misalignment of the pump and driver shafts.

To check the coupling alignment use the following directions (refer to figure 1):

- 1. Parallel alignment** is checked with a straight edge across the outside of both coupling halves. Measure distance A or B between the straight edge and both shafts. Repeat measuring at two locations 120 degrees apart on periphery of coupling. **DO NOT ROTATE COUPLING.** The difference between the three measurements for A and B must not exceed 0.005 inches at any of the positions.
- 2. Angular alignment** is checked with a dial indicator. The coupling must be disconnected before checking angular alignment. If coupling is connected with a snap-wrap spider, remove snap-wrap spider. If coupling is connected with a sox spider, remove setscrew from one coupling hub and slide hub back on shaft. Remove sox spider. Mount dial indicator on one coupling half and take a reading from back of other coupling half. Rotate coupling hub being read. Record total indicator readings at 90 degree intervals. Total indicator readout (T.I.R.) must not exceed .015 between the four readings.
- 3. Coupling gap dimensions** (dimension "C" on figure 1) are as follows:
Coupling number AL-090 is 17/32 inch.
Coupling number AL-100 is 3/4 inch.
Coupling number AL-110 is 7/8 inch.

F. DIRECTION OF ROTATION. Before connecting coupling halves, bump start driver and verify that rotation is correct. Correct pump rotation is indicated by an arrow on the pump casing. The standard direction of rotation, viewed from the motor end, is clockwise.

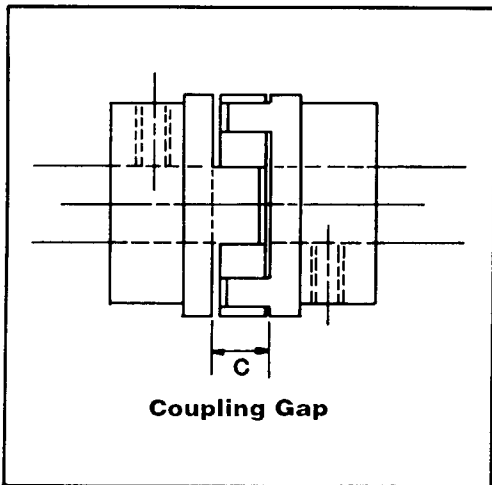
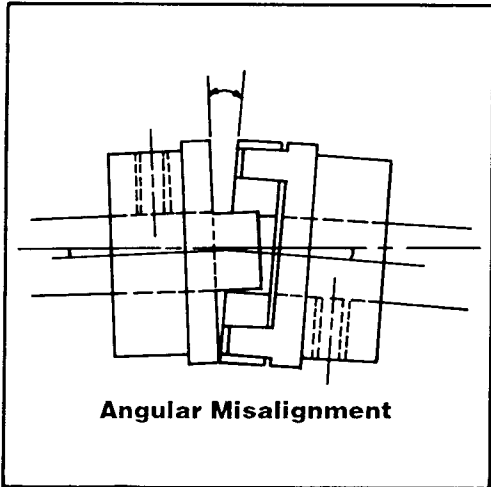
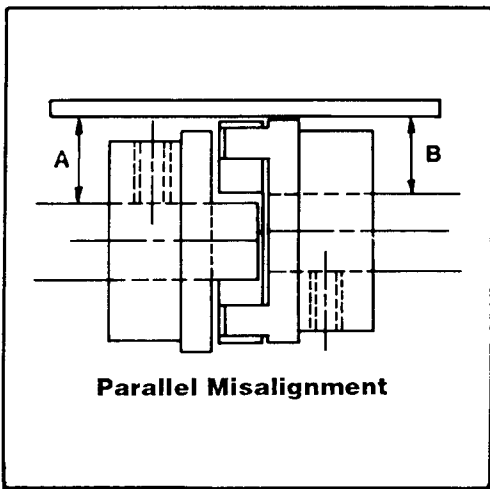

FIGURE 1. COUPLING ALIGNMENT

G. COUPLING GUARD. On frame mounted pumps, place a coupling guard over the coupling and bolt to base.

WARNING

Check safety codes and always install protective guards or shields as required by the various federal, state, or local laws and the regulations concerning OSHA.

H. GROUTING. When coupling alignment is correct and suction and discharge flanges are level, the unit should be grouted using a high grade non-shrinking grout. The entire base should be filled with grout. Be sure to fill all gaps. **ALLOW THE GROUT TO FULLY CURE BEFORE FIRMLY TIGHTENING THE FOUNDATION BOLTS.**

I. PIPING. All piping should be independently supported near the pump so that pipe strain will not be transmitted to pump casing.

CAUTION

All piping connections must be made with the pipe in a freely supported state. Do not apply vertical or side pressure to align the piping with the pump flange.

The suction and discharge piping should be one or two sizes larger than the pump flange sizes, especially where the piping is long. Any flexible joints must be equipped with tension rods to absorb piping axial thrust.

The suction pipe must be air tight and sloped upward to pump flange to avoid air pockets which will impair pump operation. The discharge pipe should be as direct as possible using a minimum number of valves to reduce pipe friction losses.

Never use a straight taper (concentric) reducer in a horizontal suction line because air pockets may form in the top of the reducer and the pipe. Use an offset (eccentric) reducer instead.

Install a check valve and closing valve in discharge line and a closing valve in suction line. The check valve, between the pump and valve, protects pump from water hammer and prevents reverse rotation in event of power failure. Closing valves are used in priming, starting, and pump shut down. Pump must never be throttled by use of a valve in the suction line.

CAUTION

After all the piping is connected, recheck the coupling alignment.

J. AUXILIARY PIPING CONNECTIONS AND GAUGES. In addition to primary piping connections, the pump may require other connections to the stuffing box drain, discharge and suction flange gauges, or baseplate drain connections. All these lines and gauges should now be installed.

K. MOTOR. See motor manufacturer instructions.

IV. OPERATION.

A. PRESTART CAUTIONS:

1. Before starting or operating the pump, read this entire manual, especially the following instructions.
2. Before starting the pump, install closed guards around all exposed rotating parts.
3. Before starting the pump, rotate shaft by hand to assure all moving parts are free.
4. Observe all caution or danger tags attached to the equipment.
5. Never run pump dry because the close running fits within the pump are water lubricated. Dry running may result in pump seizure.
6. Before starting the pump, fill the casing and suction line with liquid. The pump may be primed by using an ejector or vacuum pump.
7. Before starting a mechanical seal pump equipped with external flush lines, turn on seal water, vent seal housing, and confirm the seal water is at sufficient pressure.
8. Before starting a packed stuffing box pump, adjust the packing gland so there is sufficient leakage to lubricate the packing and assure a cool stuffing box (see maintenance instructions in section VI).
9. If excessive vibration or noise occurs during operation, shut the pump down and consult a Carver representative.

B. PRIMING. Since the liquid being pumped is used to lubricate various internal parts, dry running a centrifugal pump can result in extensive damage and possible seizing. It is, therefore, imperative that the pump be primed prior to initial start up and that prime must be maintained through subsequent start-stop cycles.

The priming procedure is different for positive and negative suction head systems. Follow the procedures listed below.

Positive Suction Head:

1. Open the vent on the highest point on the pump casing.
2. Open all suction valves.
3. Allow liquid to flow from vent hole until all air bubbles are vented. Then close vent.
4. The pump is now primed.

Negative Suction Head:

1. Install an ejector or vacuum pump on the vent at the highest point on the casing.
2. Close the discharge valve.
3. Open the suction valve.
4. Start the ejector or vacuum pump.
5. Allow liquid to flow until a continuous flow is exhausted from ejector. Then close valve to the vent.
6. The pump is now primed.

C. STARTING THE PUMP.

1. Check stuffing box or mechanical seal. Pumps that are not fitted with mechanical seals are shipped with stuffing box packing. Make sure this packing is in good order and that gland nuts are finger tightened only. Turn on flush and/or quench fluid if equipped with external flush lines.
2. Fully open the suction valve.
3. Check the pump to be sure that it is completely filled with fluid.
4. Partially open discharge valve.
5. Start the pump.
6. Slowly open discharge valve and adjust it to the operating conditions required (see pump nameplate for design point condition).

D. OPERATING CHECKS.

1. Check for undue vibration or noise. If any occurs and does not stop within a short period of time, turn off the pump. For determination of the cause and its remedy refer to troubleshooting in section V or consult Carver Pump Company.
2. For pumps fitted with stuffing box packing, tighten gland nuts equally to reduce leakage. Do not over-tighten to completely stop leakage. This will prevent sufficient lubrication to the packing causing it to burn out and fail. Overtightening of gland nuts can also cause undue wear on shaft sleeve and excessive torque load on pump shaft and driver.
3. Check and record total differential head (TDH) by deducting suction gauge reading from discharge gauge reading. In applications where suction lift is involved, add suction and discharge gauge readings. The TDH should be identical to that stamped on the pump nameplate.
4. Check and record bearing temperature. It should not exceed 180 degrees F.
5. Check and record power input to the driver.

E. STOPPING THE PUMP.

1. Stop motor.
2. Close suction and discharge valves.
3. Close external cooling water line to stuffing box if so equipped.
4. Do not tighten the packing gland to stop leaking of liquid or air unless the gland will be relieved before restarting.

F. INDEFINITE SHUTDOWN. Remove packing from stuffing box and flush stuffing box with mineral oil. Relubricate bearings. Provide pump and motor with a protective cover. Remove casing plug to drain casing. Drain all piping if there is a possibility of liquid freezing.

V. TROUBLESHOOTING OPERATING PROBLEMS.

If you have followed the installation and starting procedures outlined in this manual, the pump should provide reliable service and long life. However, if operating problems do occur, significant time and expense can be saved if you use the following check list to eliminate the most common causes of those problems.

A. NO DISCHARGE.

1. Pump not primed.
2. Speed too low.
3. Required discharge head too high.
4. Suction lift higher than pump rating.
5. Clogged or plugged impeller.
6. Wrong direction of rotation.

B. EXCESSIVE POWER CONSUMPTION.

1. Speed too high.
2. Head lower than rating; pumps too much liquid.
3. Specific gravity or viscosity of liquid pumped is too high.
4. Mechanical defects:
 - *Bent shaft.
 - *Rotating element binds.
 - *Packing gland too tight.
5. Misalignment.
6. System head lower than design condition.
7. Incorrect impeller diameter.

C. INSUFFICIENT DISCHARGE PRESSURE OR FLOW.

1. Pump not primed.
2. Speed too low. Check driver.
3. Discharge head too high.
4. Suction lift too high.
5. Wrong direction of rotation.
6. Air leaks into suction piping, stuffing box, or gaskets.
7. Impeller passage partially plugged.
8. Impeller damaged.
9. Impeller running clearance too large.
10. Impeller wear ring clearance excessive.
11. Insufficient suction line submergence.
12. Air in liquid.
13. Impeller diameter too small.
14. Insufficient net positive suction head.

D. LOSS OF SUCTION DURING OPERATION.

1. Suction line leaks.
2. Water seal line plugged.
3. Suction lift too high.
4. Air or gases in liquid.
5. Air leaks into suction piping, stuffing box, or gaskets.
6. Wrong direction of rotation.
7. Insufficient suction line submergence.

E. TOO MUCH STUFFING BOX LEAKAGE.

1. Not enough gland pressure.
2. Not enough packing in box.
3. Grooved shaft sleeve needs replacing.
4. Packing worn out.

F. VIBRATION OR NOISE.

1. Misalignment between driver and pump shafts.
2. Loose foundation bolts.
3. Defect in grouting.
4. Mechanical defects:
 - *Shaft bent.
 - *Rotating element binds.
 - *Packing gland too tight.
5. Head lower than rating; pumps too much liquid.
6. Pipe strain - improperly aligned or supported piping.
7. Pump running at shut-off condition.

G. OVERHEATING.

1. Bearings:
 - *Excessive grease.
 - *Shaft bent.
 - *Rotating element binds.
 - *Pipe strain.
 - *Insufficient bearing lubrication.
 - *Incorrect type grease.
2. Packing box:
 - *Packing gland too tight.
 - *Inferior grade of packing.
 - *Water seal line plugged.
 - *Air not vented out of mechanical seal.
 - *Flushing water not circulating for mechanical seal.

H. SPEED TOO LOW.

1. Check motor.
2. Check electrical voltage.

VI. MAINTENANCE.

Generally the pumps do not need continuous supervision. Occasional visual checks are recommended. Data should be recorded for each pump to keep track of maintenance which has been performed and to note operational problems. A maintenance record sheet is provided for this purpose at the back of this manual.

A. FIELD INSPECTION. Shutdown is not required. Perform field inspection at regular intervals and cover the following procedures:

1. Check the suction and discharge pressures to establish total differential head (TDH). It should conform to that stamped on the pump nameplate.
2. Check power input and speed of driver.
3. Check pumping temperatures.
4. Check pump for quiet running.

5. Check stuffing box for increased leakage. Adjust gland nut if required. Do not overtighten.

B. GREASE LUBRICATION OF PUMP BEARINGS. Bearings are lubricated at Carver Pump Company with Amoco Rykon Premium Grease No. 2EP, a non-soap, polyurea thickened grease with a drop point of 450 degrees F. This grease was selected because of its suitability to extreme pressures and its high temperature stability. Never mix greases with differing properties.

Polyurea base greases are **NOT** compatible with lithium or soda soap base greases. Therefore, the type of grease added should not vary. However, if it is necessary to change grease type, the bearings, bearing housings, and bearing cover should be thoroughly cleaned and flushed with suitable solvent to remove all traces of old grease as follows:

1. Place bearings, bearing housings, and bearing covers in a wire or mesh basket and suspend the basket in a light mineral solvent. Allow it to soak, preferably overnight.
2. After soaking and cleaning, the bearings, bearing housings, and bearing covers should be rinsed in a clean, light mineral solvent and agitated vigorously to remove all loosened hard grease and dirt.
3. Dip bearings in clean, light oil and spin by hand to determine that all foreign matter has been removed.
4. After cleaning, repack bearings half full on both sides with a good quality ball bearing grease.

To Relubricate Bearings use the following procedure:

1. Lubrication frequency depends on operating conditions. Relubricate every 1000 hours for normal duty.

CAUTION

Over greasing creates heat and is the cause of many problems requiring repairs. **DO NOT OVER GREASE.**

2. Bearing temperature may rise above normal immediately after lubrication, but should stabilize within 4 to 8 hours.
3. Never relubricate the pump while running.

CAUTION

Do not lubricate bearings with a power grease gun.

4. Using a hand operated grease gun on fitting located on top of bearing housing, add approximately one ounce of fresh grease for each bearing. With most hand-operated grease guns, two or three pumps is enough. **DO NOT OVER GREASE.**

C. LUBRICATION OF DRIVER. See manufacturer's special instructions to be sure driver bearings are properly lubricated.

D. STUFFING BOX WITH PACKING. A working knowledge of the stuffing box and stuffing box leakage is vital to maintenance.

Standard die-molded semi-metallic, braided asbestos packing with corrosive inhibitor is usually furnished in the pump. Use die molded rings only. **NEVER CUT BULK PACKING.**

Repacking Stuffing Box. Refer to exploded view drawings, figures 2 and 3, for location of parts followed by an item number.

1. Stop motor and lock out motor starter or disconnect switch. Drain casing (2) by removing pipe plug (35). Reinstall pipe plug in casing when fluid has completely drained.
2. Remove nuts (33) and split gland (6) from unit.
3. Remove all packing rings (39) with a packing hook. Be sure to replace packing rings located on both sides of lantern ring (40). Most L & H horizontal pumps are supplied without a recirculation line to the stuffing box and without a lantern ring. If pump is equipped with a lantern ring, slide lantern ring away from casing (2) on shaft.
4. Clean stuffing box, shaft, and shaft sleeve (4).
5. Inspect the shaft sleeve (4) for wear or rough finish and replace if necessary.

NOTE

Frequent repacking indicates a deeply grooved shaft sleeve which should be replaced.

6. Spin shaft by hand to be sure there is no binding.
7. Rub thin film of oil on shaft and in the stuffing box.
8. Twist packing rings (39) sideways to install die-molded packing. **DO NOT SPREAD RINGS AND PULL STRAIGHT ON OVER THE SHAFT.**
9. Insert one packing ring (39) next to the packing retaining ring (38). On extra large bore pumps (stuffing box bore diameter 3-1/8 inches) add two packing rings. Refer to table 1 for the number, size, and sequence of packing rings.

NOTE

If pump has a recirculation line, a lantern ring (40) is added to the stuffing box. The lantern ring is a two-piece assembly which fits together narrow face to narrow face.

5. If pump is equipped with a lantern ring (40), slide lantern ring into stuffing box. Look through water seal connection hole to line up holes in lantern ring with tapped hole in pump casing.

Table 1. Packing Requirements

	SMALL BORE	LARGE BORE	EXTRA LARGE BORE
Frame size	10P	20P	30P
Inside bore diameter in inches	2	2-5/8	3-1/8
Packing size (square)	3/8	7/16	1/2
Number of rings without lantern rings	6	5	5
Number of rings with lantern rings	5	4	4
Spacing	1-L-4	1-L-3	2-L-2

6. Insert remaining packing rings (39), staggering joints 90 to 180 degrees to minimize leakage. Insert gland (6) halves. Install gland nuts (33).

Setting New Packing. New packing should be broken in carefully. To set new packing, use the following procedure:

1. Using a wrench, tighten gland nuts (33) snugly; back off and retighten finger tight.
2. Adjust sealing liquid pressure to 10 to 15 PSI above stuffing box pressure, if applicable.
3. Start pump according to the procedures set forth in section IV.
4. Check stuffing box for overheating. Shut down to cool, if necessary.

Maintain stuffing box leakage at 30 to 60 drops a minute. Do not overtighten gland nuts. Turn sealing liquid on **BEFORE** pump is primed and leave it on as long as liquid is in the pump. Use sealing fluid to prevent air leakage if a prime is to be held when pump is stopped. Do **NOT** try to prevent air leakage by tightening gland nuts unless definite measures are taken to be sure of readjustment before starting.

Gradually pull up gland nuts alternately, one-quarter turn at a time, as packing wears from operation. **NEVER** tighten gland nuts excessively.

An additional packing ring may be added to the stuffing box after gland nuts have been taken up full travel. Repack stuffing box when gland nuts have **AGAIN** been taken up full travel.

Keep the gland straight with the shaft when tightening to avoid rubbing.

Keep spare sets of proper packing on hand.

Causes of Packing Failure and Excessive Leakage:

1. Packing not properly installed.
2. Packing not suitable for pressure and temperature.
3. Packing subject to attack by liquid being pumped.
4. Inner rings not seated properly, forcing outer rings to carry the entire load.
5. Foreign matter (dirt) in stuffing box causing rapid scoring of shaft sleeve.

E. SEAL CONNECTION. In chemical service, stuffing boxes usually are not sealed (as on water pumps) by the liquid being pumped. Sealing is required to protect against air intake, leakage of liquids that contain solids, and leakage of liquids that are costly, hazardous, or corrosive. Sealing is possible only if an independent fluid source is connected to the lantern ring with continuous, steady, external pressure at all times of operation and shutdown. Sealing fluid may be water, but if it is not compatible with the liquid being pumped, water must not be used.

F. MECHANICAL SEAL. The stuffing box of a pump equipped with a mechanical seal has been flushed with a rust preventative solution and drained before shipment.

The mechanical seals used can vary according to power frame and shaft size. PAC-SEAL 21 are standard mechanical seals for pumps with 10P and 20P power frames. John Crane Type 1 or Type 9T are standard mechanical seals for pumps with 30P power frames. Even though these mechanical seals are considered standard, the customer may request a special mechanical seal to fit the application of the pump. Consult mechanical seal manufacturer for any special instructions.

Keep a spare seal on hand if standby equipment is not available.

Mechanical Seals Are Recommended Where:

1. Leakage must be held to a minimum.
2. Shaft speeds and pressures are extremely high.
3. Abrasive and corrosive conditions are found.
4. Inflammable, volatile, or toxic liquids are pumped.

Causes of Failure or Leakage Between Seal Faces.

1. Scored or worn seal faces.
2. Gland bolted up unevenly.
3. Stationary insert face not perpendicular to shaft axis.
4. Binding seal ring.
5. Wobbling rotating seal ring.
6. Cracked or broken stationary insert.
7. Shaft run out through stuffing box.
8. Foreign matter between seal faces.
9. Loose or released setscrews.
10. Spring compression lost.
11. Mechanical seal improperly applied or installed.

VII. SERVICE AND REPAIR.

A. PREPARATIONS FOR DISASSEMBLY OF PUMP.

1. Read this entire section and study the exploded view drawings, figures 2 and 3, before disassembling the pump.
2. Lock out and tag the power to the driver.
3. Shut off all valves controlling flow of liquid to and from pump. Drain casing (2) by removing pipe plug (35). If necessary, flush pump to remove corrosive or toxic pumpage. Reinstall pipe plug in casing when fluid has completely drained.
4. Disconnect suction and discharge piping, auxiliary piping, and gauges.

CAUTION

Use of a hoist with adequate capacity is recommended.

B. DISASSEMBLY OF FRAME MOUNTED OR CLOSE COUPLED PUMP.

1. Remove coupling guard and disconnect coupling from frame mounted pump.
2. Unbolt pumping unit from base and move pumping unit to open working area.
3. Remove capscrews (26) which fasten suction head (3) to pump casing (2) and carefully break joint at casing gasket (14) and move suction head straight out so as not to damage the impeller (1) hub.
4. If pump is equipped with a mechanical seal, remove gland nuts (33) and washers (34). Pull gland (6) away from casing (2). This will relieve mechanical seal spring tension and keep impeller (1) from popping off shaft.

CAUTION

Be careful when using a puller on impeller.

5. Remove impeller capscrew (17) and impeller washers (18 and 19). The best tool to remove impeller capscrew (17) is an allen wrench welded to a socket head. Impeller may now be pulled from shaft. Remove impeller key (20).
6. If pump is equipped with a mechanical seal recirculation line from discharge side of pump casing (2) to a flush gland (6) on the mechanical seal, remove this recirculation line before removing casing.

CAUTION

Use a chain hoist and sling for heavy pieces.

7. Remove capscrews (31). Remove casing (2). On packed pumps, shaft sleeve (4), packing (39), and

split gland (6) will come off with casing.

8. On pumps fitted with packing (39), remove gland nuts (33). Remove split gland (6). Remove shaft sleeve (4). Remove packing rings (39), lantern ring (40), if equipped, and packing retaining ring (38). Remove o-ring (16) and slinger (15) from shaft.
9. On pumps fitted with a mechanical seal, remove seal spacer (5), mechanical seal (7), shaft sleeve (4), o-ring (16), gland (6), and slinger (15) from shaft.
10. Close coupled pumps with a small impeller bore (7/8 inch) have an additional spacer sleeve added between the step on motor shaft and the shaft sleeve (4). This is shown as part reference number (42) in figure 3. Note that this sleeve is painted and the end toward impeller has the greater bevel to allow for the o-ring.
11. Normally the intermediate (8) does not need to be removed from unit.

C. DISASSEMBLY OF POWER FRAME ON FRAME MOUNTED PUMP.

1. Remove inboard bearing capscrews (30).
2. Pull shaft (13) and bearing (22 and 23) assembly out through pump end of frame (9). Bearing retainer (10) will slide out with the assembly.
3. Remove bearing cap (10) from shaft (13).
4. Pry down tang on bearing lockwasher (25) and remove bearing locknut (24).
5. Bearings (22 and 23) may now be pressed off shaft.

D. PARTS INSPECTION.

1. On frame mounted pumps, inspect bearings for damage and replace if necessary. If the bearings do not need replacing, clean the bearings using the following procedures.
 - a. Place bearings in a wire or mesh basket and suspend basket in a light mineral solvent and allow to soak, preferably overnight.
 - b. After soaking and cleaning, bearings should be rinsed in a clean, light mineral solvent and agitated vigorously to remove all loosened hard grease and dirt.
 - c. Dip bearings in clean, light oil and spin by hand to determine that all foreign matter has been removed. Protect the bearings until ready for use.
2. On frame mounted pumps, inspect for bent shaft and replace shaft if necessary. Shaft threads should be in good condition. Bearing seats must be in perfect condition.
3. Shaft sleeve surface must be smooth and free of grooves. Replace if grooved. The shaft sleeve is slip fitted to the shaft for easy removal.
4. If the impeller shows excessive wear due to abrasion or corrosion, so that performance cannot be restored, it must be replaced.

Table 2. Wear Ring Clearance

MODEL (Suction x Discharge x Maximum Impeller Diameter)	FACTORY STANDARD WEAR RING CLEARANCE	
	Minimum	Maximum
1-1/4 x 1 x 6 through 3 x 2-1/2 x 10	0.012	0.021
4 x 3 x 7	0.014	0.018
4 x 3 x 10	0.012	0.021
4 x 3 x 13	0.017	0.024
5 x 4 x 7 through 5 x 4 x 13	0.015	0.023
6 x 5 x 9 and 6 x 5 x 13	0.015	0.019
6 x 5 x 10	0.014	0.016
6 x 6 x 14	0.020	0.024
8 x 6 x 11	0.019	0.023

5. If pump is equipped with suction head wear ring, check the clearance as follows:
 - a. Measure outside diameter of front impeller hub (1) in three places.
 - b. Measure inside diameter of wear ring (41) in three places.
 - c. If difference between high reading of inside diameter of wear ring (41) and low reading of outside diameter of impeller (1) hub exceeds double the maximum clearances given in table 2, replace wear ring according to section VII, paragraph H. Refer to table 2 for factory wear ring clearance.
6. If suction head on open impeller pumps shows excessive wear on the face due to abrasion or corrosion, so that performance cannot be restored, it should be replaced.
7. Inspect mechanical seal faces, gaskets, and shaft sealing members. They must be in perfect condition. Replace if necessary.
8. Replace packing if worn or damaged.
9. Inspect and replace any defective grease zerks.

E. ASSEMBLY OF FRAME MOUNTED OR CLOSE COUPLED PUMP WITH A PACKED STUFFING BOX AND SEMI-OPEN IMPELLER.

1. On frame mounted pumps, press bearings (22 and 23) on each end of shaft (13) with open sides of bearings facing bearing caps (10 and 11). Hand pack bearings half full with proper grease (refer to section VI, paragraph B). Install bearing lockwasher (25) and bearing locknut (24) on inboard end of shaft. Crimp tang of bearing lockwasher (25) in one of grooves provided in bearing locknut (24).
2. On frame mounted pumps, slide shaft (13) into bearing frame (9) from inboard side until bearings seat properly in bearing frame.
3. On frame mounted pumps, install bearing cap (10) on inboard side of bearing frame (9) and secure with socket head capscrews (30). Tighten cap-

screws evenly.

4. If intermediate (8) was removed, install it on bearing frame (9) or motor with drain hole of intermediate down. On frame mounted pumps, secure intermediate to bearing frame with capscrews (28) and nuts (29). On close coupled pumps, secure intermediate to motor with capscrews (28).
5. Install slinger (15) on shaft close to bearing frame (9) or motor. On close coupled pumps with a small impeller bore (7/8 inch), install spacer sleeve (42). Install o-ring (16) on shaft next to step on shaft.
6. Lay the casing (2) so that stuffing box is facing up. Install packing retainer (38) in casing stuffing box. Install packing rings (39) in casing stuffing box. Refer to table 1 in section VI, paragraph D for the number, size, and sequence of packing rings. The joint in each ring must be staggered 90 to 180 degrees to cut down on leakage. If pump has a recirculation line, a lantern ring (40) is provided and should be installed in accordance with table 1 in section VI, paragraph D.
7. Install shaft sleeve (4) in casing stuffing box with keyslot of shaft sleeve facing toward impeller end of shaft.
8. Install split gland (6) on casing stuffing box and secure finger tight with nuts (33) on studs (32).
9. Slide casing (2) straight over shaft and secure to intermediate (8) with capscrews (31).
10. Rotate shaft by hand until keyway in shaft lines up with keyslot in shaft sleeve (4). Install impeller key (20) in keyway in shaft and keyslot in shaft sleeve.

CAUTION

During performance of steps 11 and 12a, use old impeller capscrew (17) to secure the impeller (1). Once proper impeller clearance is achieved, use a new impeller capscrew (17) to secure impeller (1). Impeller capscrew (17) has a nylock feature and once used may not provide adequate security.

11. Install impeller (1) and impeller washers (18 and 19) on shaft and secure with impeller capscrew (17). Refer to caution above.
12. There must be a clearance of 0.010 inches minimum and 0.020 inches maximum between a semi-open impeller and the suction head. To check clearance, hold suction head (3) against impeller (1) and at same time, rotate shaft by hand and listen for any rubbing noise.
 - a. If no rubbing noise is present, the clearance between impeller and suction head will be greater than 0.020 inches, once casing gasket (14), which is 0.025 inches thick, is placed between suction head and casing. To remedy this, a 0.020 inch shim (37), is placed behind impeller to bring impeller out toward suction head. To install shim (37), remove impeller capscrew (17), impeller washers (18 and 19), and impeller (1). Install impeller shim (37) on shaft and reinstall impeller, impeller washers, and impeller capscrew (refer to caution preceding step 11). Repeat step 12a until the proper clearance is achieved.
 - b. If a rubbing noise is present, the clearance between impeller and suction head is less than 0.010 inches. To remedy this, add casing gasket (14) on suction head. Repeat step 12b until the proper clearance is achieved (refer to caution preceding step 11).
13. Install casing gasket(s) (14) on suction head. Install suction head (3) and secure to casing with capscrews (26).
14. Rotate shaft by hand to insure that shaft rotates freely and no rubbing noises are present.
15. Return pumping unit to installation site. Reinstall pumping unit on its base and secure to base with foundation bolts.
16. Reconnect suction and discharge piping, auxiliary piping, and gauges.
17. On frame mounted pumps, align coupling according to section III, paragraph E. Reconnect coupling. Reinstall coupling guard.
18. Remove all tags from valves and switches. Open system valves. Reconnect power supply to motor.
19. Start pumping unit in accordance with section IV.
20. Adjust packing according to section VI, paragraph D.

F. ASSEMBLY OF FRAME MOUNTED OR CLOSE COUPLED PUMP WITH MECHANICAL SEAL AND SEMI-OPEN IMPELLER.

1. On frame mounted pumps, press bearings (22 and 23) on each end of shaft (13) with open sides of bearings facing bearing caps (10 and 11). Hand pack bearings half full with proper grease (refer to section VI, paragraph B). Install bearing lockwasher (25) and bearing locknut (24) on inboard

end of shaft. Crimp tang of bearing lockwasher (25) in one of grooves provided in bearing locknut (24).

2. On frame mounted pumps, slide shaft (13) into bearing frame (9) from inboard side until bearings seat properly in bearing frame.
3. On frame mounted pumps, install bearing cap (10) on inboard side of bearing frame and secure with socket head capscrews (30). Tighten capscrews evenly.
4. If intermediate (8) was removed, install it on bearing frame (9) or motor with drain hole of intermediate down. On frame mounted pumps, secure intermediate to bearing frame with capscrews (28) and nuts (29). On close coupled pumps, secure intermediate to motor with capscrews (28).
5. Install slinger (15) on shaft close to bearing frame or motor. On close coupled pumps with a small impeller bore (7/8 inch), install spacer sleeve (42). Install o-ring (16) on shaft next to step on shaft.
6. Slide gland (6) on shaft as far back as possible.
7. Lubricate stationary element of mechanical seal (7) with petroleum jelly or silicon spray. Install stationary element of mechanical seal (7) on shaft and slide back next to gland (6).
8. Lubricate outside of shaft sleeve (4) with petroleum jelly or silicon spray.
9. Install mechanical seal (7) rotating element on shaft sleeve (4) and position rotary face approximately 1/8 inch from end of shaft sleeve (4) without the notch.
10. Install shaft sleeve (4) with rotating element of mechanical seal intact on shaft with keyslot of shaft sleeve facing toward impeller end of shaft.
11. Slide pump casing (2) straight over shaft, being careful not to damage mechanical seal, and secure to intermediate (8) with capscrews (31).
12. Install seal spacer (5) on shaft sleeve (4).
13. Rotate shaft by hand until keyway in shaft lines up with keyslot in shaft sleeve (4). Install impeller key (20) in keyway in shaft and keyslot in shaft sleeve.

CAUTION

During performance of steps 14 through 17a, use old impeller capscrew (17) to secure impeller (1). Once proper impeller clearance is achieved, use a new impeller capscrew (17) to secure impeller (1). Impeller capscrew (17) has a nylock feature and once used may not provide adequate security.

14. Install impeller (1) and impeller washers (18 and 19) on shaft and secure with impeller capscrew (17). Refer to caution above.
15. Slide stationary element of mechanical seal (7) into bore of casing seal box or into gland (6), if gland has provision for mounting stationary element of mechanical seal.

16. Slide gland (6) to casing (2). Secure gland to casing with washers (34) and nuts (33) on studs (32). **TIGHTEN NUTS EVENLY.**
17. There must be a clearance of 0.010 inches minimum and 0.020 inches maximum between an open impeller and suction head. To check clearance, hold suction head (3) against impeller and at same time, rotate shaft by hand and listen for any rubbing noise.
 - a. If no rubbing noise is present, the clearance between impeller and suction head will be greater than 0.020 inches, once casing gasket (14), which is 0.025 inch thick, is placed between suction head and casing. To remedy this, a 0.020 inch shim (37) is placed behind impeller to bring impeller out toward suction head. To install shim (37), remove nuts (33) and washers (34). Pull gland (6) away from casing (2). This will relieve mechanical seal spring tension and keep impeller from popping off shaft. Remove impeller capscrew (17), impeller washers (18 and 19), and impeller (1). Install impeller shim (37) on shaft. Repeat steps 14, 16 and 17a until proper clearance is achieved.
 - b. If a rubbing noise is present, the clearance between impeller and suction head is less than 0.010 inches. To remedy this, add casing gasket (14) on suction head. Repeat step 17b until the proper clearance is achieved (refer to caution preceding step 14).
18. Install casing gasket(s) (14) on suction head. Install suction head (3) and secure to casing with capscrews (26).
19. Rotate shaft by hand to insure that shaft rotates freely and no rubbing noises are present.
20. Return pumping unit to installation site. Reinstall pumping unit on its base and secure to base with foundation bolts.
21. Reconnect suction and discharge piping, auxiliary piping, and gauges.
22. On frame mounted pumps, align coupling according to section III, paragraph E. Reconnect coupling. Reinstall coupling guard.
23. Remove all tags from valves and switches. Open system valves. Reconnect power supply to motor.
24. Start pumping unit in accordance with section IV.

G. ASSEMBLY OF FRAME MOUNTED OR CLOSE COUPLED PUMP WITH ENCLOSED IMPELLER. Assembly instructions for pumps with an enclosed impeller are identical to those for the semi-open impeller except the steps which require adjustment of impeller clearance are omitted.

H. REPLACEMENT OF WEAR RING ON PUMP EQUIPPED WITH ENCLOSED IMPELLER. A pump equipped with an enclosed impeller has a replaceable wear ring inserted in the suction head. See part number 41 in figure 3.

The clearance between the wear ring and impeller hub will increase with wear. Internal leakage will result and pump performance will decrease. Refer to section VII, paragraph D5, table 2.

Usually wear ring material is matched to impeller as listed in table 3.

Table 3. Impeller and Wear Ring Matching Materials

IMPELLER MATERIAL	WEAR RING MATERIAL
Cast iron Bronze Stainless steel	Steel Bronze Alloy 20 or 17-4-PH stainless steel

To replace wear ring, use the following procedure (refer to figure 3 for location of parts followed by an item number):

1. Lock out and tag power to driver.
2. Shut off all valves controlling flow of liquid to and from pump. Drain pump casing (2) by removing pipe plug (35). If necessary, flush pump to remove corrosive or toxic pumpage. Reinstall pipe plug in casing when fluid has completely drained.
3. Disconnect suction piping, auxiliary piping, and gauges.
4. Remove capscrews (26) which fasten suction head (3) to casing (2). Carefully break joint at casing gasket (14) and move suction head straight out so as not to damage impeller (1) hub.
5. If pump is equipped with a mechanical seal, remove gland nuts (33) and washers (34). Pull gland (6) away from casing (2). This will relieve mechanical seal spring tension and keep impeller (1) from popping off shaft.

CAUTION

Be careful when using a puller on impeller.

6. Remove impeller capscrew (17) and impeller washers (18 and 19). The best tool to remove impeller capscrew (17) is an allen wrench welded to a socket head. Impeller may now be pulled from shaft. Remove impeller key (20).
7. Take suction head and impeller to a work area with access to machine shop equipment.
8. Remove wear ring (41) from suction head. This can be best accomplished on a lathe.
9. Inspect impeller hub for damage.
10. Press new wear ring (41) into suction head (3). Beveled edge of wear ring is installed toward impeller.

11. Place impeller (1) on an arbor and mount between centers in a lathe or a grinder. Indicate back of impeller hub to within 0.002 T.I.R. maximum to be sure arbor and impeller (1) are running square.
12. Turn wearing surface of impeller (1) until a 63 RMS or better finish is obtained.
13. Measure outside diameter of front impeller hub and record the value.
14. Mount suction head (3) with new wear ring (41) installed in a lathe. Indicate male rabbet to within 0.002 T.I.R. maximum.
15. Bore wear ring to within specified tolerance listed in table 2 in section VII, paragraph D5, over recorded size of outside diameter of front impeller hub.

CAUTION

During reassembly, use a new impeller cap-screw (17) to secure impeller (1). Impeller capscrew (17) has a nylock feature and once used may not provide adequate security.

16. Install impeller (1) and impeller washers (18 and 19) on shaft and secure with a new impeller cap-screw (17).
17. If pump is equipped with a mechanical seal, slide gland (6) to casing (2). Secure gland to casing with washers (34) and nuts (33) on studs (32).
TIGHTEN NUTS EVENLY.
18. Install casing gasket(s) (14) on suction head. Install suction head (3) and secure to casing with capscrews (26).
19. Reconnect suction piping, auxiliary piping, and gauges.
20. Remove all tags from valves and switches. Open system valves. Reconnect power supply to motor.
21. Start pumping unit in accordance with Section IV.

I. PARTS INVENTORY GUIDE. To avoid unnecessary delays for maintenance, spare parts should be on

hand for normal service. Most conditions may be covered if this guide is followed. For every one to three pumps, stock one spare parts set consisting of items listed in table 4. Part numbers listed in table 4 correspond to part numbers on the exploded view drawings.

J. PARTS ORDERING. There are a variety of options available for these pumps. When ordering parts, prompt accurate service will be provided if you will tell Carver Pump Company the following information.

1. Serial number of pump (located on nameplate).
2. Part name (located on parts list).
3. Part number (located on exploded view).
4. Quantity of parts needed.

Carver Pump Company may ship an interchangeable part that is not identical in appearance or symbol. This is done only if the part has been improved. Examine parts carefully upon delivery before questioning factory or representative. Never return parts to the factory without authorization from Carver Pump Company.

If an impeller is ordered, specify diameter across blade tips. Be sure diameter was not trimmed further than diameter shown on Carver Pump Company records.

If a motor or motor parts are ordered, specify name of manufacturer and all other data on driver nameplate.

VIII. PARTS LISTS AND EXPLODED VIEW DRAWINGS.

This section contains listings of parts and corresponding exploded view drawings. Table 5 contains the parts listing for frame mounted pumps. Figure 2 shows location of parts listed in table 5. Table 6 contains the parts listing for close coupled pumps. Figure 3 shows location of parts listed in table 6.

Table 4. Recommended Spare Parts

QUANTITY	PART NUMBER	DESCRIPTION
1	39, 40, 6, and 7	Set of stuffing box packing and gland, or mechanical seal
1	22 and 23	Inboard and outboard bearing
1	13	Shaft
1	4	Shaft sleeve
2	16	Shaft sleeve o-rings
1	17	Impeller capscrew
1	1	Impeller
1	41	Wear ring, for pump with enclosed impeller
As req'd	14	Casing gasket
As req'd	37	Impeller shims, .020 inch for pump with semi-open impeller

Table 5. Parts List for Frame Mounted L & H Horizontal Pump

PART NUMBER	PART DESCRIPTION	PART NUMBER	PART DESCRIPTION
1	Impeller (semi-open version is shown)	21	Coupling Key
2	Casing	22	Thrust Bearing
3	Suction Head	23	Radial Bearing
4	Shaft Sleeve	24	Bearing Locknut
5	Seal Spacer	25	Bearing Lockwasher
6	Gland	26	Hex Head Capscrew
7	Mechanical Seal	27	Hex Head Capscrew
8	Intermediate	28	Hex Head Capscrew
9	Bearing Frame	29	Hex Nut
10	Bearing Cap - Inboard	30	Socket Head Capscrew
11	Bearing Cap - Outboard	31	Hex Head Capscrew
12	Frame Foot	32	Stud
13	Shaft	33	Hex Nut
14	Casing Gasket	34	Washer
15	Slinger	35	Pipe Plug
16	O-ring	36	Grease Zerk
17	Socket Head Capscrew	37	Impeller Shim (with semi-open impeller)
18	Impeller Washer	38	Packing Retaining Ring
19	Impeller Washer	39	Packing Ring
20	Impeller Key	40	Lantern Ring (optional)

Table 6. Parts List for Close Coupled L & H Horizontal Pump

PART NUMBER	PART DESCRIPTION	PART NUMBER	PART DESCRIPTION
1	Impeller (enclosed version is shown)	26	Hex Head Capscrew
2	Casing	28	Hex Head Capscrew
3	Suction Head	31	Hex Head Capscrew
4	Shaft Sleeve	32	Stud
5	Seal Spacer	33	Hex Nut
6	Gland	34	Washer
7	Mechanical Seal	35	Pipe Plug
8	Intermediate	38	Packing Retaining Ring
14	Casing Gasket	39	Packing Ring
15	Slinger	40	Lantern Ring (optional)
16	O-ring	41	Wear Ring (with enclosed impeller)
17	Socket Head Capscrew	42	Spacer Sleeve (for pump with 7/8 inch impeller bore)
18	Impeller Washer		
19	Impeller Washer		
20	Impeller Key	43	Motor

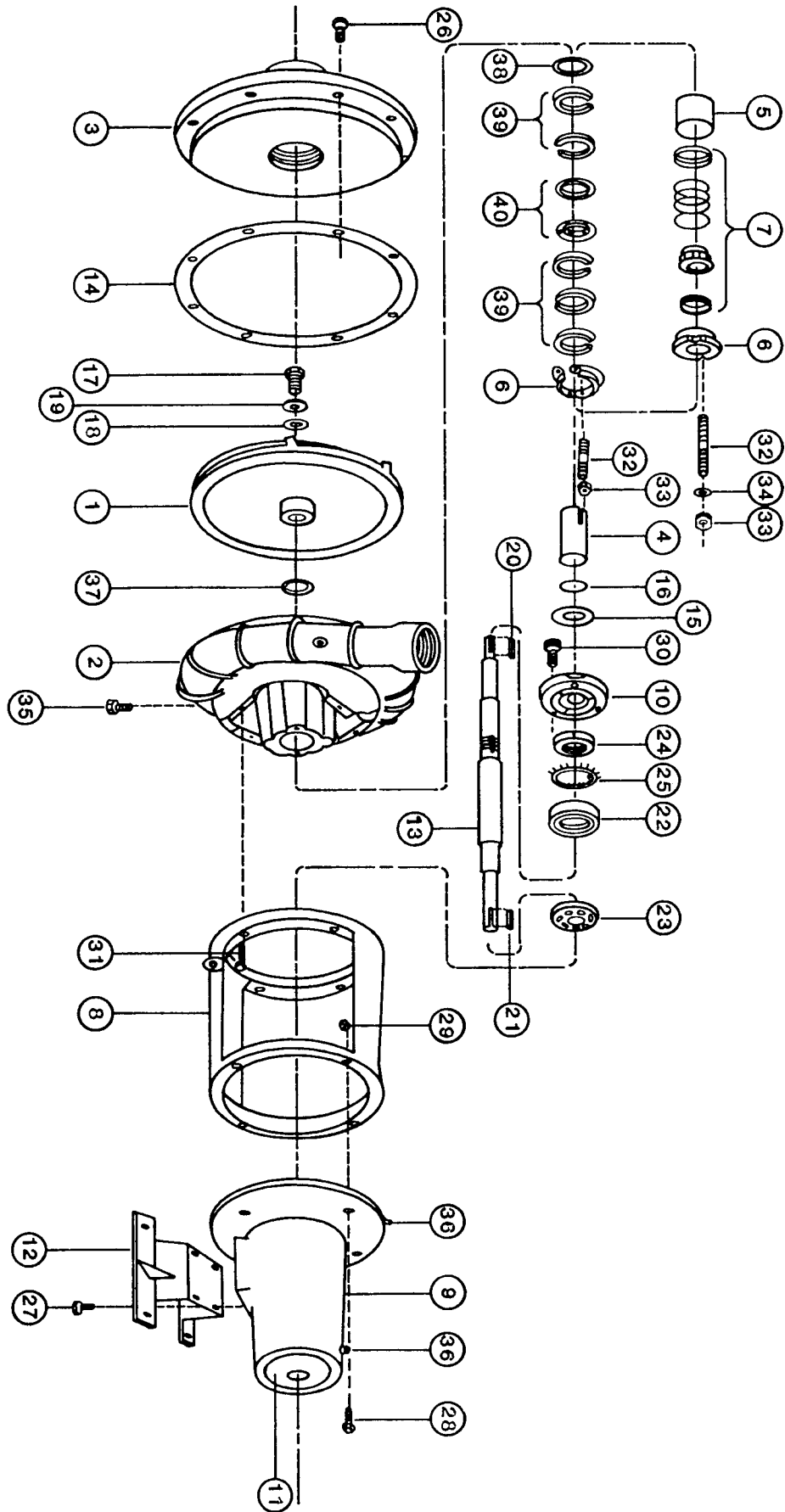

FIGURE 2. EXPLODED VIEW FOR FRAME MOUNTED L & H HORIZONTAL PUMP

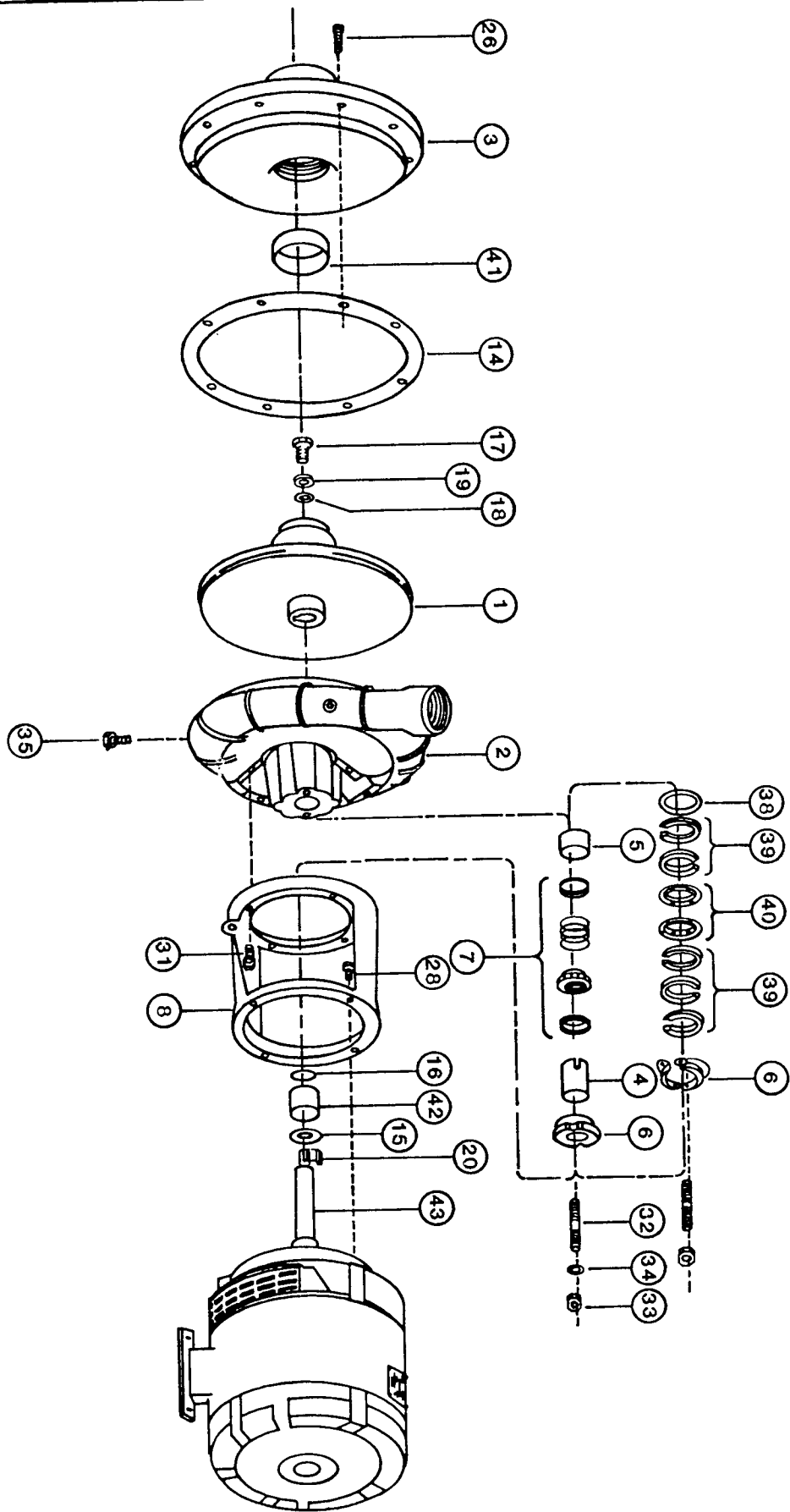

FIGURE 3. EXPLODED VIEW FOR CLOSE COUPLED L & H HORIZONTAL PUMP

SECTION IX. PUMP SERVICE RECORD

Serial Number _____ Customer Order Number _____

Size and Type _____ Make _____

Date Installed _____ Pump Location _____

Application _____

PUMP RATING

Capacity (GPM) _____ Total Head (feet) _____

Suction Head (+ / - feet) _____ Speed (RPM) _____

Liquid _____ Liquid Temperature _____

Specific Gravity _____ Viscosity _____ Impeller Diameter (inches) _____

PUMP MATERIALS

Casing _____ Suction Head _____

Intermediate _____ Bearing Frame _____

Impeller _____ Wear Ring _____ Shaft _____

Shaft Sleeve _____ Mechanical Seal or Packing _____

MOTOR DATA

Serial Number _____ Type _____

Make _____ Frame Size _____

Horsepower _____ Speed (RPM) _____

AC or DC _____ Volts _____

Phase _____ Cycles _____

NOTES ON INSPECTION AND REPAIRS

INSPECT DATE	REPAIR TIME	REPAIRS	COST	REMARKS

NOTES: _____



Carver Pump Company

2415 Park Avenue • Muscatine, IA 52761-5691
563.263.3410 • Fax: 563.262.0510

e-mail: carverpump@muscanet.com
web: www.carverpump.com