

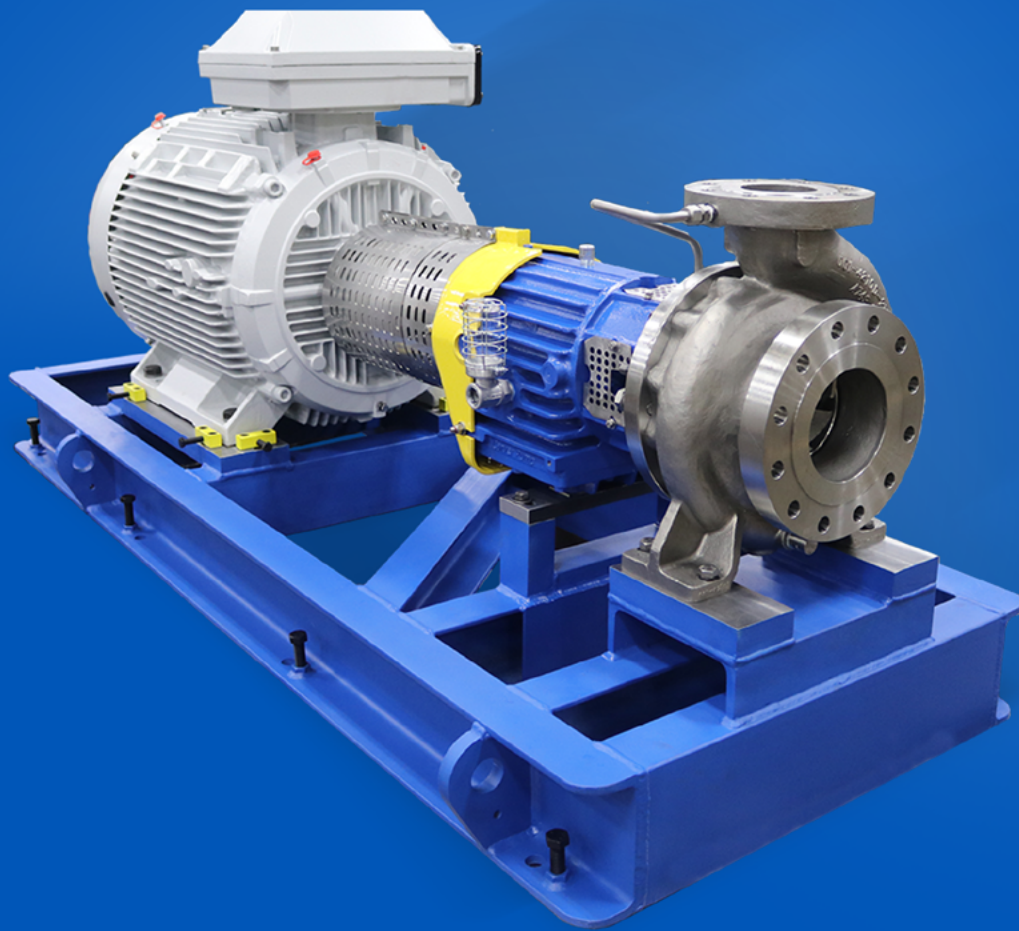

**CARVER PUMP™**

Built for purpose



---

## **MAXUM OH1**

Heavy-Duty, Horizontal

End-Suction Pump



## MAXUM OH1

Our heavy-duty, horizontal end-suction pump for hydrocarbons and process industry applications.

Designed as a foot-mounted version of our API centerline-mounted Maxum OH2, the Maxum OH1 is an industry workhorse. The Maxum OH1 can be motor, engine, or turbine-driven and is ideal for water, hydrocarbons, caustic and acid applications. With hydraulic performance to 11,000 GPM and 720 feet of head, this pump family is available in carbon steel, 12% chrome, 316L and duplex stainless steel, according to standard API material codes. In addition to these, higher alloys such as Alloy 20, Hastelloy B or C, Monel and titanium are also available.

As standard, these units come with oil-lubricated bearings with labyrinth isolators, and connections for temperature probes. Common options include various cartridge seals and API piping systems. Flanged or NPT auxiliary connections, cooling jackets, spacer couplings, and various levels of performance testing are also available, depending on users' requirements. Available heavy-duty baseplates result in maximum flange loadings

that meet or exceed the requirements of API 610. With some of the most efficient hydraulics in the industry, the Maxum offers the reliability, low lifetime cost, and lasting value that have made Carver one of the most trusted names in pumps.

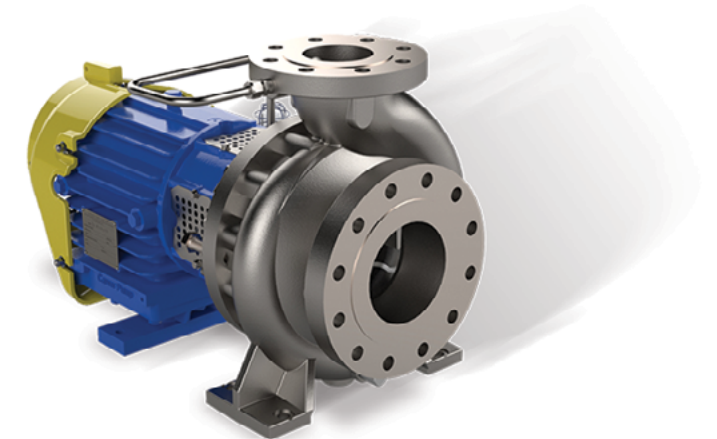

MAXUM OH1



### PUMPS BUILT FOR THE API MARKET

Our Maxum OH1 is used in multiple oil and gas applications, including the transfer of crude oil. This tank farm, located in Wyoming, receives crude oil via a pipeline from Canada. Here, five of our Maxum OH1 pumps are used in various applications, including moving the crude throughout the facility for blending, and from storage tanks into rail cars or tanker trucks for transport.

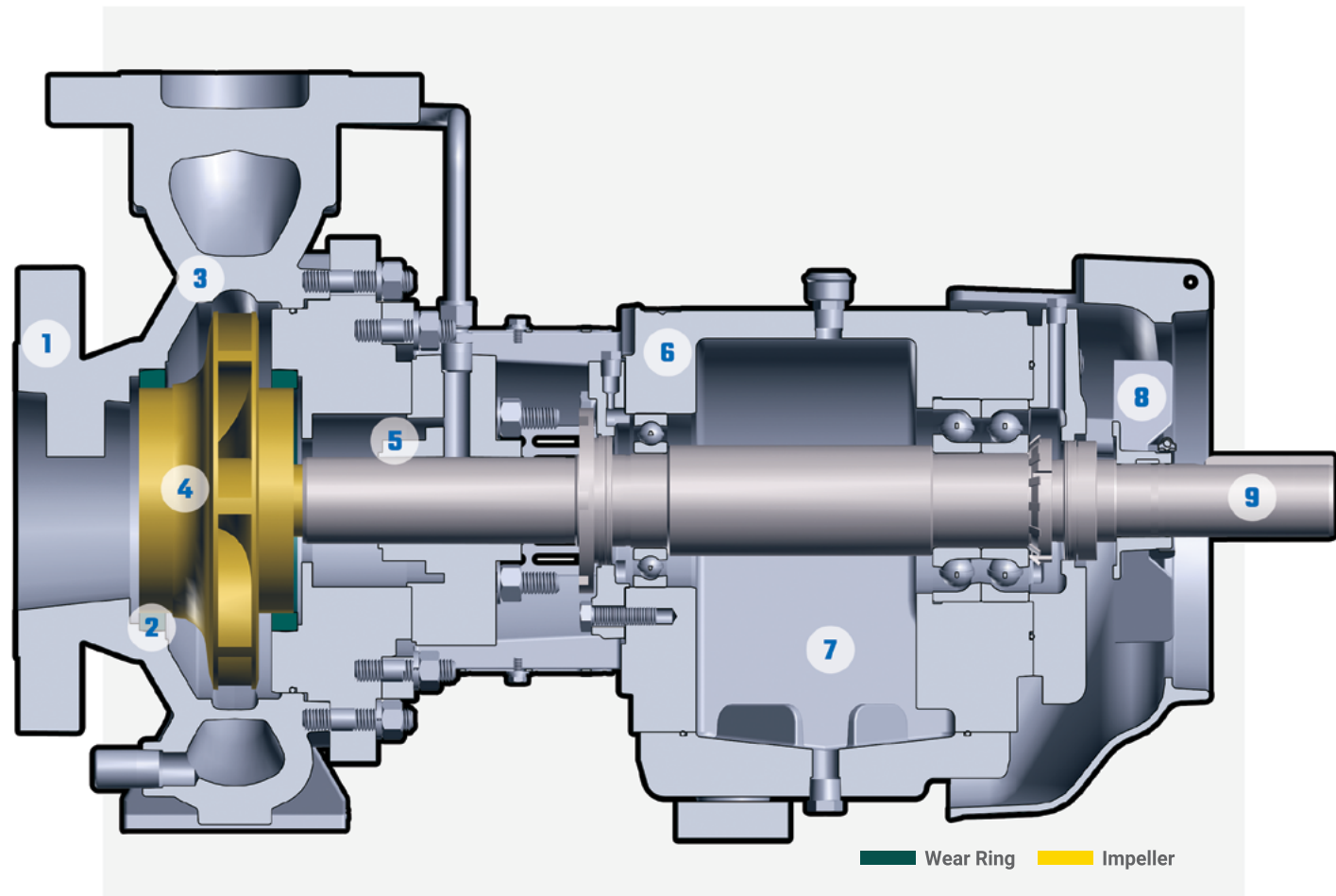

**1 CONNECTIONS**

Class 300 ANSI flanges with centerline discharge assist in self-venting

**2 WEAR RINGS**

Replaceable casing and backhead wear rings maintain efficiency and balanced axial loads

**3 CASING**

Back pull-out design with registered fits and fully-confined gaskets assure sealing and alignment of critical fits. Casing drains included as standard. Centerline mount options available

**4 IMPELLERS**

Enclosed, high-efficiency impellers balanced to ISO 1940, Grade G2.5 for vibration-free operation. All impellers are keyed to shaft

**5 API 610 SEAL CHAMBER**

Provides an ideal seal environment for both single/dual, pressurized/unpressurized cartridge mechanical seals. A full range of API 682 piping plans is also available, to maximize seal life

**6 BEARING FRAME**

Heavy-duty bearing housing with cooling fins. Fan and labyrinth seals keep oil clean and cool, for greater bearing life.

**7 BEARING LUBRICATION**

Oil-lubricated bearings with standard flooded or optional flinger lubrication. Conversion to purge oil mist or pure oil mist is possible without additional machining

**8 COOLING FAN**

Allows ambient temperatures to 100° F and fluid temperatures to 600° F in centerline mount configuration. The cooling fan also extends bearing life

**9 SHAFTS**

Minimal shaft deflection extends mechanical seal and wear ring life

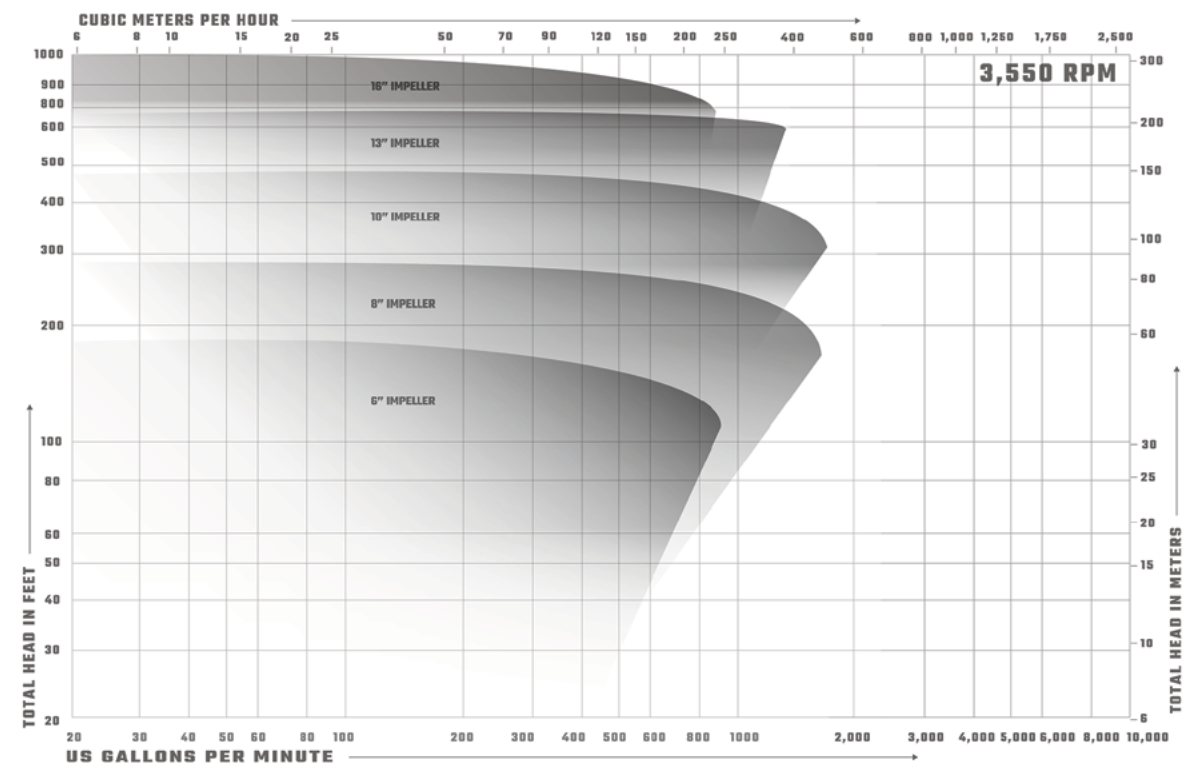
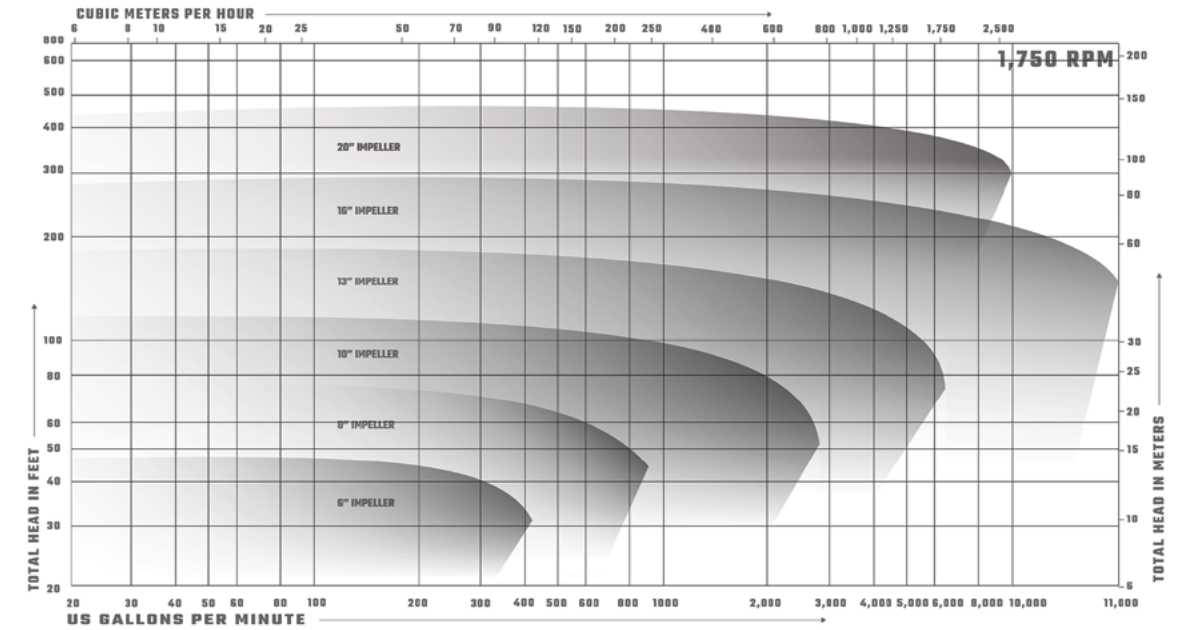

Quality Management System Approval Certification Number 95-370h



## WHY A MAXUM OH1?

- Combined bearing life exceeds 25,000 hours.
- Shaft design dramatically reduces deflection, thereby increasing seal life and reducing vibration when operating away from best efficiency point.
- Oil mist lubrication available as a pre-engineered option.
- Heavy-duty baseplate designed for operation without deflection, excessive vibration or resonance.

### HYDRAULICS

- Flows to 11,000 US GPM (2,498 m<sup>3</sup>/hr)
- Heads to 720 feet (220 m)
- Efficiencies to 88%
- Power to 900 HP (670 KW)
- Temperatures to 300° F (149° C)
- Speeds to 3,550 RPM

### APPLICATIONS

- Desalination/Municipal
- Industrial
- Minerals & Mining
- Oil & Gas
- Petrochemical
- Power Generation
- Acid Leaching Processes

### MATERIALS OF CONSTRUCTION

Commonly Used Materials	WCB Carbon Steel, 12% Chrome, 316 SS and CD4MCuN Duplex
API Material Codes	S1, S3, S4, S5, S6, S8, S9, A8, C6, D1 and D2
Severe Duty Materials	Hastelloy B, Hastelloy C, 254 SMO, 654 SMO and Titanium

Other materials available, including coatings and composites, to meet specific application requirements.

### MECHANICAL DATA

Rotation	Clockwise from Fan End of Motor
Maximum Input	Power Capable of 1,500 HP @ 1,750 RPM
Connections	Class 300 ANSI Flanges
Bearings	Oil Lubricated

## DISCOVER OUR PUMPS



**GH - HORIZONTAL END-SUCTION PUMP**



**RS - MULTISTAGE RING SECTION PUMP**



**API MAXUM OH2 - END-SUCTION PUMP**



**KWP - NON-CLOGGING PROCESS PUMP**



**850 - HORIZONTAL FILTRATE PUMP**

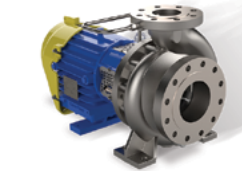

**MAXUM OH1- HEAVY-DUTY, HORIZONTAL END-SUCTION PUMP**



**855 - TANK-MOUNTED FILTRATE PUMP**



**RSV - VERTICAL IN-LINE MULTISTAGE PUMP**



**VLO - VERTICAL LUBE OIL PUMP**



**G2C - VERTICAL CANTILEVER PUMP**



**G2S - VERTICAL SUMP PUMP**



**OH3 - VERTICAL IN-LINE PUMP**



**KEF - SELF PRIME PUMP**



**M SERIES - ASTM F998 CLOSE-COUPLED PUMP**



**PACKAGED PUMP SYSTEM**



**UL508A LISTED CONTROL PANELS**



## 85 years of experience

Since we built our first pumps, Carver Pump has become recognized as one of the leading centrifugal pump companies, building to the most demanding engineering specifications and military standards in the world.

Carver Pump's quality management system is certified by Intertek to conform to ISO 9001:2015. Our commitment to quality includes not only our

hardware, but also superior customer service, leading-edge R&D, and continuous improvement in everything we do.

So whether the job is refueling fighter jets on the deck of an aircraft carrier, supplying paint to an auto assembly line, or bringing water to the fountain in a city park, we put our reputation on the line everyday with every pump we build.

## Contact us

2415 Park Avenue  
Muscatine, Iowa 52761-5691  
USA

(563) 263-3410  
[sales@carverpump.com](mailto:sales@carverpump.com)  
[www.carverpump.com](http://www.carverpump.com)

