



I-402
402 – 17.04.EN
ATEX
Inch Units

Maxum OH1 – End Suction Process Pump

INSTALLATION, OPERATION AND MAINTENANCE INSTRUCTIONS

Part Number: _____

Serial Numbers: _____

 These operating instructions contain fundamental information and precautionary notes. Please read the manual thoroughly prior to installation of unit, electrical connection and commissioning. It is imperative to comply with all other operating instructions referring to components of individual units.

 This manual shall always be kept close to the unit's location of operation or directly on the pump set.



MANUFACTURER: CARVER PUMP COMPANY
2415 PARK AVE.
MUSCATINE, IOWA, USA 52761

www.carverpump.com
Phone: 1-563-263-3410
Email: sales@carverpump.com

PRODUCT DESCRIPTION: Maxum OH1 Pump

PART NUMBER:

SERIAL NUMBER:

DATE MANUFACTURED:

APPLICABLE EUROPEAN DIRECTIVES:

Machinery: The designated product complies with the following basic requirements of Directive 2006/42/EC:
Appendix I, section 1.1.2, 1.1.3., 1.1.5., 1.3.1., 1.3.2., 1.3.3., 1.3.4., 1.3.7., 1.3.8., 1.4.1., 1.4.2.1.,
1.5.1., 1.5.8., 1.5.9., 1.5.13., 1.6.1., 1.6.4., 1.6.5., 1.7.

ATEX: 94/9/EC

APPLICABLE INTERNATIONAL STANDARDS:

Machinery: EN ISO 12100:2010 EN ISO 13732-1:2008
 EN 626-1:2008 EN ISO 13857:2008

ATEX: EN 1127-1, EN 13463-1, EN 13463-5

NOTIFIED BODY

Det Norske Veritas, ATEX NB 0575 retains a copy of the Technical File

ATEX product marking:   II 2 G c T1

The product described in this Declaration of Conformity complies with the Applicable European Directives and relevant sections of the Applicable International Standards. The signature on this document authorizes the distinctive European mark to be applied to the equipment described. A Technical Construction File is available for inspection by designated bodies

Authorized Signature:

Date:

Mike Moyer
Engineering Manager



Important safety information is contained in the installation, operation and service manuals; read and understand this information prior to installing or using this equipment

This Document applies only to the equipment described above and is invalid if not reproduced in its entirety.

SERVICE RECORD PAGE

Service No. _____ Model _____ Size and Type _____

Customer Order No. _____ Date Installed _____

Installation Date	Location	Application

PUMP RATING

Capacity _____ Total Head _____

Suction Pressure _____ Speed (RPM) _____

Liquid pumped _____ Temperature _____

Specific Gravity _____ Viscosity _____

Service _____

PUMP MATERIALS

Casing _____ Impeller _____ Shaft _____

Gaskets _____ Bearing Frame _____

Mechanical Seal/Packing _____

MOTOR DATA

Motor _____ Make _____ Serial No. _____

Type _____ Frame _____ AC or DC _____

HP _____ RPM _____ Volts _____

Phase _____ Cycles _____

NOTES ON INSPECTION AND REPAIRS

INSPECTION DATE	REPAIR TIME	REPAIRS	COST	REMARKS

INSTALLATION, OPERATION AND MAINTENANCE INSTRUCTIONS

TABLE OF CONTENTS

SECTION/PARAGRAPH	PAGE	SECTION/PARAGRAPH	PAGE
I. GENERAL DESCRIPTION.....	1	C. Foundation	14
A. General Information	1	D. Leveling of Unit	15
B. ATEX Directive 94/9/EC.....	1	E. Grouting	15
C. Disclaimer	1	F. Coupling Alignment.....	17
D. Personnel Qualification and Training.....	1	G. Pre-Installation Procedures	18
E. Pump Identification.....	1	H. Piping	18
F. Parts Inventory Guide	2	I. Auxiliary Piping Connection	
G. Parts Ordering.....	2	and Gauges	18
II. SAFETY.....	2	J. Motor	18
A. Safety Precautions	2	K. Direction of Rotation	18
B. Summary of Safety Marking.....	2	VIII. OPERATION	19
C. Products Used in Potentially Explosive		A. Pre-Start Cautions	19
Atmospheres	2	B. Priming.....	19
D. Scope of Compliance	3	C. Starting the Pump	20
E. Safety Awareness	3	D. Turbine Applications	20
F. Safety Instructions for the Operator/User ..	3	E. Minimum/Maximum Flow Calculations	20
G. Safety Instructions for Maintenance		F. Operating Checks	20
Inspection and Installation Work.....	3	G. Stopping the Pump	20
H. Non-Compliance with Safety Instructions ..	3	H. Indefinite Shutdown	21
I. Unauthorized Modification and		IX. TROUBLESHOOTING OPERATING	
Manufacture of Spare Parts	4	PROBLEMS.....	21
J. Unauthorized Modes of Operation	4	X. MAINTENANCE	23
K. Explosion Protection	4	A. Lubrication of Pump Ball Bearings.....	23
III. EQUIPMENT DESCRIPTION.....	6	B. Lubrication of Motor Ball Bearings.....	24
IV. EFFECTS OF FLUIDS	8	C. Torque Values.....	24
A. Net Positive Suction Head (NPSH).....	8	XI. SERVICE AND REPAIR.....	25
B. Changing Pump Speed.....	8	A. Preparations for Disassembly of Pump	25
C. Effects of Viscosity	8	B. Disassembly of Pump	29
D. Effects of Specific Gravity	8	C. Parts Inspection	33
V. TECHNICAL DATA.....	8	D. Reassembly of Pump.....	34
VI. INSPECTION AND STORAGE	13	E. Replacement of Wear Ring.....	35
A. Inspection	13	F. Motor	38
B. Packing for Return	13	G. Check Valve	38
C. Storage of Pump	13	XII. PARTS LISTS AND DRAWINGS	38
VII. INSTALLATION	14		
A. Location.....	14		
B. Handling	14		

TABLE OF CONTENTS - Continued

LIST OF TABLES			LIST OF ILLUSTRATIONS		
NUMBER	TITLE	PAGE	NUMBER	TITLE	PAGE
1.	Fluid Temperature Limits	5	1.	Seal Chamber Dimensions	9
2.	Basic Design Features	10	2.	Sling Position for Moving Pump	14
3.	Key Mechanical Data	11	3.	Sling Position for Moving Pumping Unit	14
4.	Permissible Nozzle Loads	12	4.	Grouting and Foundation Bolting	16
5.	Pumping Unit Troubleshooting	21	5.	Unit Leveling	16
6.	Oil Recommendations	24	6.	Coupling Alignment	17
7.	Recommended Torque Values (ft-lbs)	24	7.	Constant Level Oiler	24
8.	Recommended Equipment	24	8.	Draining the Pumping Unit	26
9.	Factory Wear Ring Clearance (Inches)	34	9.	Preparation to Remove Back Pull-Out	27
10.	Recommended Spare Parts List	39	10.	Remove Coupling	28
11.	Parts List	42	11.	Remove Back Pull-Out	28
			12.	Back Pull-Out, Inboard Exploded View	30
			13.	Back Pull-Out, Outboard Exploded View	32
			14.	Inducer	39
			15.	Exploded View of Complete Pump for Reference	40
			16.	Pump with Base	41
			17.	Wet End Low Flow High Head Option	43
			18.	Flanged Drain and Discharge Option with Plan 11	43

I. GENERAL DESCRIPTION AND SAFETY PRECAUTIONS.

A. GENERAL INFORMATION. Carver Pump Company products are carefully engineered and manufactured and, if properly installed, maintained, and operated, should provide maintenance-free operation and a long service life.



These instructions must always be kept close to the product's operating location or directly with the product.

This manual is designed to provide sufficient material to properly maintain the pumping unit. The information presented should improve your knowledge and understanding of the Maxum OH1, thus upgrading the reliability, service life, and quality of pump maintenance.

These operating instructions are intended to facilitate familiarization with the product and its permitted use to help satisfy ATEX safety requirements. These operating instructions do not take into account local regulations; the operator must ensure that such regulations are strictly observed by all, including the personnel called in for installation. Compliance with such laws relating to the proper installation and safe operation of the pumping equipment is the responsibility of the equipment owner and all necessary steps should be taken by the owner to assure compliance with such laws before operating the equipment. Always coordinate repair activity with operations personnel and follow all plant safety requirements and applicable safety and health laws/regulations.

Refer to Figures 8 through 13, the exploded views and Figure 16, pump with base, to locate the pump parts by item number. Variations do exist between configurations, not all parts described in the text may be on your configuration.



These instructions should be read prior to installing, operating, using and maintaining the equipment in any region worldwide and in conjunction with the main user instructions provided. The equipment must not be put into service until all the conditions relating to safety instructions have been met.

B. ATEX DIRECTIVE 94/9/EC. It is a legal requirement that machinery and equipment put into service within certain regions of the world shall conform to the applicable CE Marking Directives for Equipment for Potentially Explosive Atmospheres (ATEX).

Where applicable the Directive covers important safety aspects relating to the equipment, its use and the satisfactory provision of technical documents. Where applicable this document incorporates information relevant to these Directives. To establish if the product itself is CE marked for a Potentially Explosive Atmosphere check the nameplate and the Certification provided.

C. DISCLAIMER. Information in these User Instructions is believed to be reliable. In spite of all the efforts of Carver Pump Company to provide sound and all necessary information the content of this manual may appear insufficient and is not guaranteed by Carver Pump Company as to its completeness or accuracy.

D. PERSONNEL QUALIFICATION AND TRAINING.

All personnel involved in the operation, installation, inspection and maintenance of the unit must be qualified to carry out the work involved. If the personnel in question do not already possess the necessary knowledge and skill, appropriate training and instruction must be provided. If required, the operator may commission the manufacturer/supplier to provide applicable training.

Follow instructions in this manual carefully. Factory warranty applies only when pump operates under conditions as specified on order acknowledgment, and if pump is properly installed and maintained as recommended herein. A copy of this manual should be available to operating personnel. Additional copies of this manual are available upon request from Carver Pump Company and your local distributor. For comments and/or questions about information provided, please contact Carver Pump Company or your local distributor.

E. PUMP IDENTIFICATION. The type of pump, pump size, operating data, and serial number are all stamped on the nameplate attached to the pump. Pump specifications should be recorded upon receipt of the pumping unit. Record all necessary information on the pump service record page and inspection and repair record provided at the front of this manual. This information must be included in all correspondence regarding the unit. This will ensure that the correct pump and/or parts are ordered in a timely manner.

F. PARTS INVENTORY GUIDE. To avoid unnecessary delays for maintenance, spare parts should be readily available, purchased before and kept in stock, for normal service. Most conditions will be covered if this manual is followed. For every one to three pumps, stock one spare set consisting of items listed in Table 10, Recommended Spare Parts. Part numbers correspond to Figures 8 through 13, the exploded views and Figure 16, pump with base.

G. PARTS ORDERING. When ordering replacement parts, please specify:

- Serial number of pump (located on nameplate)
- Part name (located on parts list)
- Quantity of parts needed

Carver Pump Company may ship an interchangeable part that is not identical in appearance or symbol. This is done only if the part has been improved. Examine parts carefully upon delivery before questioning factory or company representative. Never return parts to the factory without authorization from Carver Pump Company.

If an impeller is ordered, specify diameter across blade tips. Be sure diameter was NOT trimmed further than diameter shown on Carver Pump Company records.

If a driver or driver parts are ordered, specify name of manufacturer and all other data found on the driver nameplate.

II. SAFETY.

A. SAFETY PRECAUTIONS. The manual is designed to provide adequate instructions for the safe and efficient installation, operation, or maintenance of the pump. Failure or neglect to properly install, operate, or maintain the pump may result in personal injury, property damage, or unnecessary damage to the pump. This manual must be read and understood both by the installing personnel and the responsible trained personnel/operators prior to installation and operation, and it must always be kept close to the location of the pumping unit for easy access.

B. SUMMARY OF SAFETY MARKING. The safety instructions contained in this manual follow specific ATEX safety marking where non-observance of the instruction will cause a hazard is specially marked with the symbol:



This symbol indicates explosive atmosphere marking according to ATEX. It is used in safety instructions where non-compliance in the hazardous area would cause the risk of an explosion.



General hazard sign to ISO 7000 - 0434.

The word "Caution" is used to introduce safety instructions whose non-observance may lead to damage to the machine and its functions.

The word "WARNING" is used to introduce safety instructions whose non-observance may lead to a potential hazard exists, capable of producing injury to personnel, if approved procedures are not followed.

The word "DANGER" indicates a location, equipment, or system where imminent hazards exist, capable of producing immediate injury or death to personnel, if approved procedures are not followed.

Instructions attached directly to the machine, e.g.

- Arrow indicating the direction of rotation
- Markings for fluid connections must always be complied with and be kept in a perfectly legible condition at all times.

Observe all notes, caution, warning or danger tags attached to the equipment or included in this manual.

C. PRODUCTS USED IN POTENTIALLY EXPLOSIVE ATMOSPHERES



Measures are required to:

- Avoid excess temperature
- Prevent buildup of explosive mixtures
- Prevent the generation of sparks
- Prevent leakages
- Maintain the pump to avoid hazard

The following instructions for pumps and pump units when installed in potentially explosive atmospheres must be followed to help ensure explosion protection. Both electrical and non-electrical equipment must meet the requirements of European Directive 94/9/EC.

D. SCOPE OF COMPLIANCE.



Use equipment only in the zone for which it is appropriate. Always check that the driver, drive coupling assembly, seal and pump equipment are suitably rated and/or certified for the classification of the specific atmosphere in which they are to be installed.

Where Carver Pump has supplied only the bare shaft pump, the Ex rating applies only to the pump. The party responsible for assembling the pump set shall select the coupling, driver, seal and any additional equipment, with the necessary CE Certificate/Declaration of Conformity establishing it is suitable for the area in which it is to be installed.

The output from a variable frequency drive (VFD) can cause additional heating affects in the motor and so, for pump sets with a VFD, the ATEX Certification for the motor must state that it covers the situation where electrical supply is from the VFD. This particular requirement still applies even if the VFD is in a safe area.

E. SAFETY AWARENESS. It is imperative to comply with the safety instructions contained in this manual, the relevant national and international explosion protection regulations, health and safety regulations and the operator's own internal work, operation and safety regulations.



Ex symbol relates to additional requirements which must be adhered to when the pump is operated in potentially explosive atmospheres.

F. SAFETY INSTRUCTIONS FOR THE OPERATOR /USER.

- Any hot or cold components that could pose a hazard must be equipped with a guard by the operator.
- Guards which are fitted to prevent accidental contact with moving parts (e.g. coupling) must not be removed whilst the unit is operating.
- Leakages (e.g. at the bearing isolators) of hazardous fluids (e.g. explosive, toxic, hot) must be contained so as to avoid any danger to persons or the environment. Pertinent legal provisions must be adhered to.
- Electrical hazards must be eliminated. (In this respect refer to the relevant safety regulations

applicable to different countries and/or the local energy supply companies.)



If the pumps/units are located in potentially explosive atmospheres, it is imperative to make sure that unauthorized modes of operation are prevented. Non-compliance may result in the specified temperature limits being exceeded.

G. SAFETY INSTRUCTIONS FOR MAINTENANCE, INSPECTION AND INSTALLATION WORK.

The operator is responsible for ensuring that all maintenance, inspection and installation work be performed by authorized, qualified personnel who are thoroughly familiar with the manual and pumping unit.



To ensure safe operation the radial and thrust ball bearings must be replaced at 25,000 hours of service or whenever the mechanical seal is inspected or serviced.

The pumping unit must have cooled down to ambient temperature, pump pressure must have been released and the pump must have been drained before working on any pumping unit. Work on the pumping unit must be carried out during shutdown. The shutdown procedure described in the manual for taking the unit out of service must be adhered to.

Pumps handling fluids that are hazardous to personnel must be decontaminated prior to being worked on.

Immediately following completion of the work, all safety relevant and protective devices must be reinstalled and/or reactivated. Please observe all instructions set out in the section on start-up before returning the pumping unit to service.

H. NON-COMPLIANCE WITH SAFETY INSTRUCTIONS.

Non-compliance with safety instructions may result in personal injury, property damage, or unnecessary damage to the pumping unit. Non-compliance with these safety instructions will also lead to forfeiture of any and all rights to claims for damages. Non-compliance, can for example, result in:

- Failure of important pumping unit functions.
- Failure of prescribed maintenance and servicing practices.
- Hazard to personnel by electrical, mechanical, and chemical effects as well as explosion.
- Hazard to the environment due to leakage of hazardous substances.

I. UNAUTHORIZED MODIFICATION AND MANUFACTURE OF SPARE PARTS.

Modifications or alterations of the pumping unit supplied are only permitted after consultation with Carver Pump and to the extent permitted by Carver Pump. Original spare parts and accessories authorized by Carver Pump ensure safety. The use of other parts can invalidate any liability of Carver Pump for consequential damage and/or warranty.

J. UNAUTHORIZED MODES OF OPERATION. The warranty relating to operating reliability and safety of the unit supplied is only valid if the pumping unit is used in accordance with its designated use as described in the following sections. The limits stated on the nameplate must not be exceeded under any circumstances.

K. EXPLOSION PROTECTION. If the pumps/units are installed in potentially explosive atmospheres, the measures and instructions given in the following sections K.1 to K.6 must be adhered to without fail, to ensure explosion protection.

K.1 Unit Fill.



It is assumed that the system of suction and discharge lines and thus the wetted pump internals are completely filled with the fluid to be handled at all times during pump operation, so that an explosive atmosphere is prevented.



If the operator cannot warrant this condition, appropriate monitoring devices must be used.



In addition, it is imperative to make sure that the seal chambers, auxiliary systems of the shaft seal and the heating and cooling systems are properly filled.

K.2 Marking.



The marking on the pump only refers to the pump, i.e. the coupling and driver must be regarded separately. The coupling must have an EC manufacturer's declaration. The driver must be regarded separately.

An example of ATEX equipment marking is shown below. The actual classification of the pump will be engraved on the nameplate.

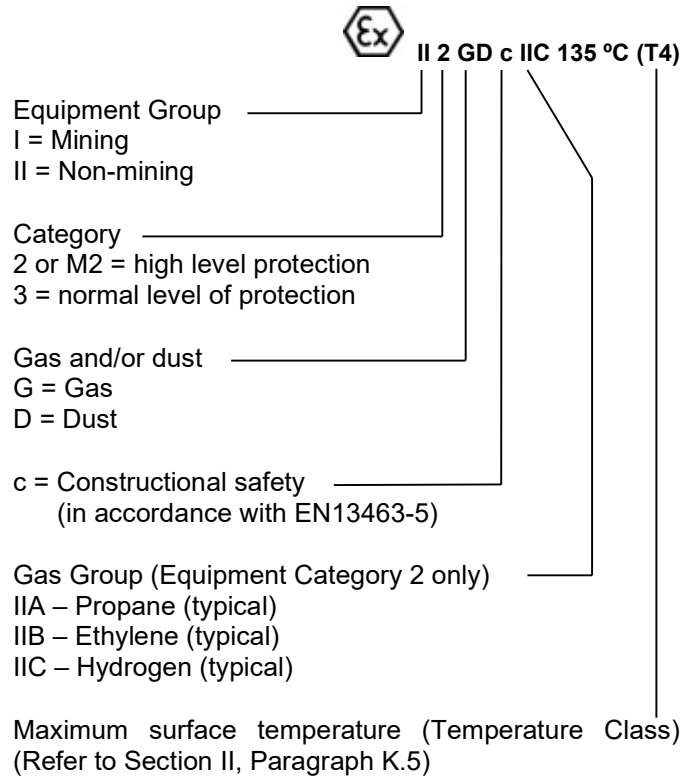

K.3 Checking the Direction of Rotation.



If the explosion hazard also exists during the installation phase, the direction of rotation must never be checked by starting up the unfilled pump unit, even for a short period, to prevent temperature increases resulting from contact between rotating and stationary components.

K.4 Pump Operating Mode.

Make sure that the pump is always started with the suction-side shut-off valve fully open and the discharge-side shut-off valve slightly open. However, the pump can also be started up against a closed swing check valve. The discharge-side shut-off valve shall be adjusted to comply with the duty point immediately following the run-up process.



Pump operation with the shut-off valves in the suction and/or discharge pipes closed is not permitted.



CAUTION

In this condition, there is a risk of the pump casing taking on high surface temperatures after a very short time, due to a rapid temperature rise in the pumped fluid inside the pump. Additionally, the resulting rapid pressure build-up inside the pump may cause excessive stresses on the pump materials or even bursting.

The minimum flows calculated in Section VIII, Paragraph E, refer to water and water-like liquids. Longer operating periods with these liquids and at the flow rates indicated will not cause an additional increase in the temperatures on the pump surface. However, if the physical properties of the fluids handled are different from water, it is essential to check if an additional heat build-up may occur and if the minimum flow rate must therefore be increased.

To check, proceed as described in Section VIII, Paragraph E.

In addition, the instructions given in Section VIII of this operating manual must be observed.



Mechanical seals may exceed the specified temperature limits if run dry. Dry running may not only result from an inadequately filled seal chamber, but also from excessive gas content in the fluid handled.

Pump operation outside its specified operating range may also result in dry running.

K.5 Temperature Limits.



In normal pump operation, the highest temperatures are to be expected on the surface of the pump casing, at the shaft seal and in the ball bearing areas. The surface temperature at the pump casing corresponds to the temperature of the fluid handled.

If the pump is heated, it must be ensured that the temperature classes stipulated for the plant are observed.

In the ball bearing bracket area, the unit surfaces must be freely exposed to the atmosphere and the fan inlet flow must be unimpeded.



In any case, responsibility for compliance with the specified fluid temperature (operating temperature) lies with the plant operator. The maximum permissible fluid temperature depends on the temperature class to be complied with.

Table 1 below lists the temperature classes to EN 13463-1 and the resulting theoretical temperature limits of the fluid handled. In stipulating these temperatures, any temperature rise in the shaft seal area has already been taken into account.

Table 1. Fluid Temperature Limits

Temperature class to EN 13463-1:	Temperature limit of fluid handled
T5	185 °F (85 °C)
T4	284 °F (120 °C)
T3	300 °F (149 °C)



CAUTION

The permissible operating temperature of the pump in question is indicated on the data sheet. If the pump is to be operated at a higher temperature, the data sheet is missing or if the pump is part of a pool of pumps, the maximum permissible operating temperature must be enquired from the pump manufacturer.

Based on an ambient temperature of 104° Fahrenheit (F) [40° Celsius (C)] and proper maintenance and operation, compliance with temperature class T4 is warranted in the area of the rolling element ball bearings. A special design is required for compliance with temperature class T6 in the ball bearing area. In such cases, or if ambient temperature exceeds 104°F (40°C), contact the manufacturer.

K.6 Maintenance.



Only a pumping unit which is properly serviced and maintained in perfect technical condition will give safe and reliable operation.

This also applies to the reliable function of the thrust and radial ball bearings whose actual lifetime largely depends on the operating mode and operating conditions. Regular checks of the lubricant and the running noises will prevent the risk of excessive temperatures as a result of the thrust or radial ball bearings running hot or defective bearing deflectors.

The correct function of the bearing deflectors must be checked regularly. Any auxiliary systems installed must be monitored, as necessary, to make sure that they function correctly.

K.7 General Safety Instructions.

- Various federal, state, and local laws affect installation, use, and operation of pumping equipment. Compliance with such laws relating to proper installation and safe operation of pumping equipment is the responsibility of the equipment owner.
- Prior to working on pump or driver, ensure all switches and circuit breakers have been locked in the open (off) position and tagged, "Out of Service."
- All circuits NOT known to be dead must be considered live at all times.
- DO NOT wear loose or torn clothing around rotating machines.
- While working near electricity, DO NOT use metal rules, flashlights, metallic pencils, or any other objects having exposed conducting material.
- Make sure you are NOT grounded while adjusting electrical equipment or using measuring equipment.
- In general, use only one hand when servicing live electrical equipment.
- Make sure to de-energize all electrical equipment before connecting or disconnecting meters or test leads.
- For connecting a meter to terminals for measurement, use a range higher than the expected voltage.

- Check to make sure that the frame of the driver and starter panel are securely grounded before operating pumping unit or performing any tests or measurements.
- If a test meter must be held or adjusted while voltage is applied, ground case of meter before starting measurement. DO NOT touch live equipment while holding the meter. Some moving vane-type meters should not be grounded nor held during measurements.
- DO NOT use test equipment known to be damaged or in poor condition.

The following specific safety precautions apply to the pumping unit:

- DO NOT exceed maximum discharge pressure.

III. EQUIPMENT DESCRIPTION.

The Maxum OH1 is our process pump for handling hydrocarbons in refining and process industry applications. It is offered as a foot mounted unit. Hydraulic performance extends to 9,000 GPM and 720 feet of head. The design is restricted as noted below.

The Maxum OH1 unit consists of a pump, base, coupling, coupling guard and a driver unit. The driver is usually an electric motor, but can be a steam turbine or any other power conversion device that can provide the required horsepower at the proper RPM. Drivers other than electric motors must be reviewed for compliance with the applicable directives.

The Maxum OH1 is supplied with a casing that should always be mounted solidly on an adequate bedplate. No shims should be used under the feet of the casing.

The Maxum OH1 is designed as a back pullout unit. Therefore it should always be used with a spacer coupling. The spacer width should permit the entire rotating assembly to be removed from the casing. Normally the casing should be left in place on the base and remain connected to the suction and discharge piping.

The bare pump consists of following major parts and options. Refer to Figures 8 through 13, the exploded views and Figure 16, Pump with Base, drawings for the location of parts identified by item numbers.

Item 1 - Casing. The casing (1) houses the impeller (2) and wear ring (7*) and consists of the suction inlet, and discharge nozzle. The back cover (11) is held in place between the casing and the bearing frame (19). The casing is fastened to the back cover with casing/back cover studs (820D) and casing hex nuts (830F).

Item 2 or 3 - Impeller. Maxum pumps are equipped with enclosed impellers, except the low-flow high-head Maxum pumps that are equipped with open impellers. The impeller (2 or 3) is keyed to the shaft (6) by the impeller key (32A) and is locked in place by the impeller washer (28) and impeller nut (24) or optional inducer (*246).

Item 6 – Shaft. The shaft (6) of the Maxum pump is designed for maximum deflection of 0.002 inch at the face of the mechanical seal (90). The shaft is also designed to provide stabilization to the rotor system when pump operates away from the best efficiency point. A coupling (42) connects the shaft to the driver (200) shaft. The pump coupling key (32C) holds the coupling in place, causing it to rotate with the shaft.

Item 11 – Back Cover. The back cover (11) is fastened to the casing (1) with casing/back cover studs (820D) and casing hex nuts (830F). The back cover houses the back cover wear ring (7A). The back cover is sealed in the casing by the casing gasket (*73D) or O-ring (*700B).

The bearing frame (19) is attached to the back cover (11) with back cover stud (820E) and back cover hex nut (830F).

The back cover (11) contains forcing bolts (808A) to aid in loosening the back cover from the casing (1).

Item 16 and 18 – Ball Bearings. A deep-groove Conrad-type, C3 internal fit radial ball bearing (16) and light preload, back-to-back mounted thrust ball bearings (18) are housed in the bearing frame (19). Thrust ball bearings will be duplex 40° angular contact ball bearings. The thrust ball bearing is held in place by the bearing locknut (22) and bearing lockwasher (69). The ball bearings are oil lubricated. Either oil bath lubrication or an oil mist system may be employed.

Item 19 – Bearing Frame. The principal function of the bearing frame (19) is to carry the loads from the liquid end of the pump to the base and to transport power from the power unit to the impeller (2). The bearing frame has a radial ball bearing (16) located in the front end of the bearing frame (nearest to the casing) and a pair of back-to-back mounted angular contact thrust ball bearings (18) in the rear of the bearing frame. This bearing frame is designed to be oil lubricated, which can be accomplished in several ways.

The first method involves the use of a sight glass constant level oiler (890A). The sight glass maintains the oil level high enough on the higher of the two bearings so that the bearings themselves provide the motivation for the oil to be moved through the races of the bearings.

A second method is to provide an oil flinger (*60) which mounts on the shaft (6) and literally flings the oil throughout the bearing frame. An oil view sight (*143) is usually used with this system to make sure that the oil level within the frame can be observed and maintained at the proper level.

A third method is the oil mist system. All Maxum pumps are equipped so that they can be used or can be converted to oil mist units without any field machining-.



Oil Mist system for ATEX applications require a user installed system of safety controls or alarms to ensure that the pump is shut down in event of an oil mist failure.

In addition to the oil lube system, the bearing frame (19) contains the deflector seals (715 & 716). The Maxum pump bearing frame is equipped with a labyrinth oil seal assembly which becomes a static seal when stopped.

Item 23 – Base. The base (23) is designed to provide adequate support for the pump and motor so pump can be operated without base deflection, excessive vibration, or resonance. The casing (1) is attached to the base with bolts (808D) and lockwashers (840J). Grouting of this type of base is required by Carver Pump Company.

Item 90 – Mechanical Seal. Cartridge mechanical seals (90) are to be used. Complete cartridge mechanical seal instructions should be obtained from the seal manufacturer. The standard seal chamber dimensions are shown in Figure 1.

IV. EFFECTS OF FLUIDS.



Solids pumped in the fluid may cause internal damage to pump casing and damage to the seal faces with resulting hazardous conditions. Care is to be taken to ensure that the process fluid is clear of solids and debris.

A. NET POSITIVE SUCTION HEAD (NPSH). Any liquid, hot or cold, must be pushed into the impeller of the pump by some absolute pressure, such as the atmosphere or the vessel pressure from which the pump takes its action.

The head in feet of liquid necessary to maintain the required flow into the pump is called the Net Positive Suction Head (NPSH). This value is measured above the vapor pressure of the liquid at the pumping temperature.

NPSH is commonly expressed in two ways: the NPSH required by the pump, and shown on the pump curve, is the head needed to cover the losses in the pump suction and the energy required to enable the liquid to climb onboard the leading edge of the impeller vane. The NPSH available is that inherent in the system, taking into account friction losses in suction piping, valves, fittings, etc. In all cases, the NPSH available, measured above vapor pressure, must exceed the NPSH required in order to push the liquid into the pump.

B. CHANGING PUMP SPEED. Changing the speed of a centrifugal pump affects the capacity, total head, NPSH required and the brake horsepower. In general, the capacity will vary in a direct ratio with the speed, whereas the total head and NPSH required will vary as the ratio of the speed squared. The brake horsepower will vary as the ratio of the speed cubed.

C. EFFECTS OF VISCOSITY. The pump is designed to deliver rated capacity at rated head for a liquid with a particular viscosity. When pump is handling heavy viscous liquid, the viscosity of the liquid must allow it to be pumped easily. The liquid may have to be heated prior to starting the pump. When contemplating

operation at some viscosity other than that for which the pump was originally designed, check with Carver Pump Company.

D. EFFECTS OF SPECIFIC GRAVITY. The capacity and total head in feet of liquid developed by a centrifugal pump are fixed for every point on the curve and are always the same for the same speed. Neither capacity nor total head will be affected by a change in the specific gravity of the liquid pumped. However, since the discharge pressure in Pounds per Square Inch (PSI) and the brake horsepower required driving the pump are functions of the specific gravity of the liquid, both will be affected in direct proportion by any change in specific gravity. Therefore, an increase in specific gravity will raise the discharge pressure and is dangerous as it might overload the pump's driver or exceed the pump casing allowable pressure.

V. TECHNICAL DATA.

Specifications and operating limits should be recorded on a Service Record Page; an example is located in the front matter of this manual. Record the necessary information upon receipt of the pumping unit.

Seal Chamber Dimensions. Standard seal chamber dimensions are located in Figure 1 and are arranged by bearing frame number.

Basic Design Features. Basic design features of the pump are located in Table 2 and are arranged by pump size.

Key Mechanical Data. Key mechanical data for the pump is located in Table 3 and is arranged by bearing frame number.

Permissible Nozzle Loads. The forces and moments in Table 4 are to be understood as the limit for a single acting force or moment along the particular coordinate axes or any resultant of two or more forces and moment.

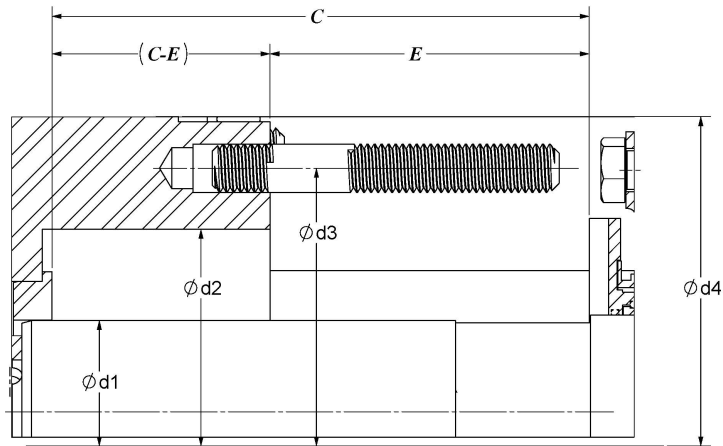

Seal Chamber Dimensions (Inches)									
Bearing Frame Number	Pump Size	Shaft Diameter d1	Box Bore d2	Stud Circle d3	Max Gland Diameter d4	Total Length C	Clear Length E	Box Depth C-E	Stud Size (Qty = 4)
3	6	1.5748/1.5742	3.5430/3.5444	4.921	6.625	6.500	4.000	2.500	1/2"-13UNC
4	8	1.9685/1.9679	3.9370/3.9384	5.512	6.625	6.900	4.400	2.500	5/8"-11UNC
5	10	2.3622/2.3615	4.7244/4.7258	6.300	7.750	6.900	4.400	2.500	5/8"-11UNC
6	13	2.5000/2.4995	5.1181/5.1197	6.693	7.750	6.900	4.400	2.500	5/8"-11UNC
8	16 & 20	3.5433/2.5424	6.2992/6.3008	8.070	10.875	7.290	4.790	2.500	3/4"-10UNC

Figure 1. Seal Chamber Dimensions

Table 2. Basic Design Features

Pump Size	Bearing Frame	Max Speed (RPM)	1 st Critical Speed (RPM)	Casing Design		Shaft Deflection @ 20% BEP		Shaft Stiffness L ³ /D ⁴	WK ² @ Max. Impeller Dia.
				*Discharge	Volute(s)	@ Seal (in.)	@ Impeller (in.)		
AA- 1½ x 1 x 6	3	3500	13068	Centerline	Single	0.0002	0.0009	183.3	9.500
AB - 2 x 1½ x 6	3	3500	12098	Centerline	Single	0.0006	0.0019	183.3	10.45
AC- 3 x 1½ x 6	3	3500	11317	Centerline	Single	0.0006	0.0021	183.3	11.40
AD - 3 x 2 x 6	3	3500	12098	Centerline	Single	0.0011	0.0036	183.3	10.45
AE - 4 x 3 x 6	3	3500	10122	Centerline	Dual	0.0021	0.0070	183.3	15.20
BA - 1½ x 1 x 8	4	3500	12262	Centerline	Single	0.0003	0.0011	83.6	34.31
BB - 2 x 1½ x 8	4	3500	10754	Centerline	Single	0.0005	0.0017	83.6	41.42
BC - 3 x 1½ x 8	4	3500	11193	Centerline	Single	0.0006	0.0022	83.6	39.05
BD - 3 x 2 x 8	4	3500	11193	Centerline	Single	0.0008	0.0029	83.6	39.05
BE – 4 x 3 x 8	4	3500	10363	Centerline	Dual	0.0004	0.0014	83.6	43.79
BF - 6 x 4 x 8	4	3500	10012	Centerline	Dual	0.0005	0.0017	83.6	46.16
CA – 2 x 1½ x 10	5	3500	13192	Centerline	Single	0.0002	0.0012	42.3	92.29
CB - 3 x 1½ x 10	5	3500	13192	Centerline	Single	0.0002	0.0011	42.3	92.29
CC - 3 x 2 x 10	5	3500	12773	Centerline	Single	0.0004	0.0022	42.3	92.29
CD - 4 x 3 x 10	5	3500	12042	Centerline	Quad	0.0006	0.0032	42.3	108.6
CE - 6 x 4 x 10	5	3500	10429	Centerline	Dual	0.0002	0.0012	42.3	141.3
CF - 6 x 6 x 10	5	1750	8288	Centerline	Dual	0.0002	0.0010	42.3	141.3
CG - 8 x 6 x 10	5	1750	10020	Centerline	Dual	0.0002	0.0012	42.3	152.2
DA - 2 x 1½ x 13	6	3500	11224	Centerline	Single	0.0003	0.0019	35.0	209.6
DB - 3 x 2 x 13	6	3500	8511	Centerline	Single	0.0005	0.0026	35.0	201.8
DC - 4 x 3 x 13	6	3500	9515	Centerline	Quad	0.0009	0.0054	35.0	263.8
DD - 6 x 4 x 13	6	3500	9098	Centerline	Dual	0.0002	0.0013	35.0	287.1
DE - 6 x 6 x 13	6	1750	8306	Centerline	Dual	0.0002	0.0010	35.0	310.3
DF - 8 x 6 x 13	6	1750	7130	Centerline	Dual	0.0003	0.0016	35.0	310.3
DG - 10 x 8 x 13	6	1750	6728	Centerline	Dual	0.0004	0.0023	35.0	418.9
DH – 12 x 10 x 13	6	1750	6215	Centerline	Dual	0.0008	0.0043	35.0	418.9
ED- 6 x 4 x 16	8	1750	8223	Centerline	Dual	0.0001	0.0005	19.5	563.6
EA- 8 x 6 x 16	8	1750	7885	Centerline	Dual	0.0001	0.0011	19.5	647.3
EB - 10 x 8 x 16	8	1750	9053	Centerline	Dual	0.0001	0.0012	19.5	595.9
EE - 12 x 10 x 16	8	1750	7840	Centerline	Dual	0.0001	0.0006	19.5	722.6
EC - 14 x 12 x 16	8	1750	7752	Centerline	Dual	0.0004	0.0035	19.5	849.4
FA - 8 x 6 x 20	8	1750	7478	Centerline	Dual	0.0001	0.0012	19.5	1232.0
FB - 10 x 8 x 20	8	1750	7288	Centerline	Dual	0.0002	0.0018	19.5	1495.0
FC - 12 x 10 x 20	8	1750	6714	Centerline	Dual	0.0003	0.0026	19.5	1859.0
FD - 14 x 12 x 20	8	1750	6075	Centerline	Dual	0.0005	0.0039	19.5	2298.0

*Low-flow high-head casing discharge design is tangential.

Table 3. Key Mechanical Data

Item	Bearing Frame				
	3	4	5	6	8
Max power (BHP) @ 3500 RPM	150	240	550	550	-
@ 1750 RPM	75	120	275	275	1500
@ 1150 RPM	50	80	180	180	1000
Bearing type - radial ball bearing	6211	6211	6213	6213	6219
thrust ball bearing	7311	7311	7313	7313	7318
Lubrication method (standard)	Oil - ISO Grade 22, 32 or 68				
L ₁₀ bearing life (hrs) - radial	50,000				
thrust	50,000				
Radial to thrust ball bearing centerline (in.)	5.192	5.192	8.939	8.939	13.198
Shaft diameter (in.) @ coupling	1.375	1.375	2.000	2.000	3.000
@ impeller hub (standard ext.)	1.000	1.375	1.375	1.875	2.375
@ radial ball bearing	2.166	2.166	2.559	2.559	3.741
@ thrust ball bearing	2.166	2.166	2.559	2.559	3.544
@ seal box	1.575	1.968	2.362	2.500	3.543
Coupling Key – width (in.)	0.313	0.313	0.500	0.500	0.750
length (in.)	2.625	2.625	2.000	2.000	5.000

Table 4. Permissible Nozzle Loads

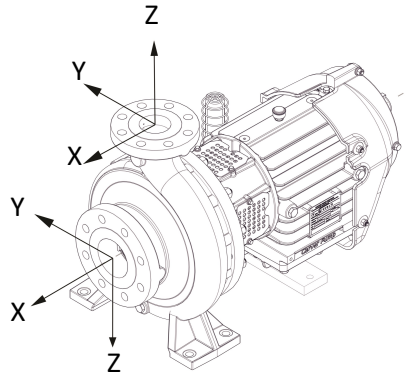

Pump Size	Suction						Discharge					
	Fx	Fy	Fz	Mx	My	Mz	Fx	Fy	Fz	Mx	My	Mz
AA- 1½ x 1 x 6	200	160	130	340	170	260	160	130	200	340	170	200
AB - 2 x 1½ x 6	200	160	130	340	170	260	160	130	200	340	170	200
AC- 3 x 1½ x 6	300	240	200	700	350	530	160	130	200	340	170	200
AD - 3 x 2 x 6	300	240	200	700	350	530	160	130	200	340	170	200
AE - 4 x 3 x 6	400	320	260	980	500	740	240	200	300	700	350	530
BA - 1½ x 1 x 8	200	160	130	340	170	260	160	130	200	340	170	200
BB - 2 x 1½ x 8	200	160	130	340	170	260	160	130	200	340	170	200
BC - 3 x 1½ x 8	300	240	200	700	350	530	160	130	200	340	170	200
BD - 3 x 2 x 8	300	240	200	700	350	530	160	130	200	340	170	200
BE - 4 x 3 x 8	400	320	260	980	500	740	240	200	300	700	350	530
BF - 6 x 4 x 8	700	560	460	1700	870	1,300	320	260	400	980	500	740
CA - 2 x 1½ x 10	200	160	130	340	170	260	160	130	200	340	170	200
CB - 3 x 1½ x 10	300	240	200	700	350	530	160	130	200	340	170	200
CC - 3 x 2 x 10	300	240	200	700	350	530	160	130	200	340	170	200
CD - 4 x 3 x 10	400	320	260	980	500	740	240	200	300	700	350	530
CE - 6 x 4 x 10	700	560	460	1700	870	1,300	320	260	400	980	500	740
CF - 6 x 6 x 10	700	560	460	1700	870	1,300	560	460	700	1700	870	1300
CG - 8 x 6 x 10	1100	850	700	2600	1,300	1,900	560	460	700	1700	870	1300
DA - 2 x 1½ x 13	200	160	130	340	170	260	160	130	200	340	170	200
DB - 3 x 2 x 13	300	240	200	700	350	530	160	130	200	340	170	200
DC - 4 x 3 x 13	400	320	260	980	500	740	240	200	300	700	350	530
DD - 6 x 4 x 13	700	560	460	1700	870	1,300	320	260	400	980	500	740
DE - 6 x 6 x 13	700	560	460	1700	870	1,300	560	460	700	1700	870	1300
DF - 8 x 6 x 13	1100	850	700	2600	1,300	1,900	560	460	700	1700	870	1300
DG - 10 x 8 x 13	1500	1200	1000	3700	1800	2800	850	700	1100	2600	1,300	1,900
DH - 12 x 10 x 13	1800	1500	1200	4500	2200	3400	1200	1000	1500	3700	1800	2800
ED- 6 x 4 x 16	700	560	460	1700	870	1,300	320	260	400	980	500	740
EA- 8 x 6 x 16	1100	850	700	2600	1,300	1,900	560	460	700	1700	870	1300
EB - 10 x 8 x 16	1500	1200	1000	3700	1800	2800	850	700	1100	2600	1,300	1,900
EE - 12 x 10 x 16	1800	1500	1200	4500	2200	3400	1200	1000	1500	3700	1800	2800
EC - 14 x 12 x 16	2000	1600	1300	4700	2300	6300	1,500	1200	1800	4500	2200	3400
FA - 8 x 6 x 20	1100	850	700	2600	1,300	1,900	560	460	700	1700	870	1300
FB - 10 x 8 x 20	1500	1200	1000	3700	1800	2,870	850	700	1100	2600	1,300	1,900
FC - 12 x 10 x 20	1800	1500	1200	4500	2200	3400	1200	1000	1500	3700	1800	2800
FD - 14 x 12 x 20	2000	1600	1300	4700	2300	6300	1,500	1200	1800	4500	2200	3400

M = Moments measured in Foot-Pounds (FT-lbs)

F = Forces measured in Pounds (lbs)

VI. INSPECTION AND STORAGE.



A. INSPECTION. Upon receipt of the shipment, unpack and inspect the pumping unit and individual parts to insure none are missing or damaged. Carefully inspect all boxes and packing material for loose parts before discarding them. Check to make sure the shipment complies with the purchase order. Immediately report any missing parts or damage incurred during shipment to the factory and to the Transportation Company and file your “damage and/or lost in shipment” claim with the carrier.

B. PACKING FOR RETURN. If the pumping unit is sent back to Carver Pump Company for repair, drain the unit, and re-seal all flanges and connections that were covered or plugged. Ship the pump(s) in an assembled condition to prevent damage to sealing faces of individual components. A Return Goods Authorization (RGA) and a Safety Data Sheet (SDS) is required on all returned pumps. Copies of SDS records should be kept and maintained by the customer. The customer is responsible for cleaning and flushing the pump before it is returned to the factory. Make sure to specify the fluid used in the service.

C. STORAGE OF PUMP. If the equipment is not to be immediately installed and operated, store it in a clean, dry, well ventilated place, free from vibrations, moisture and rapid or wide variations in temperature.

NOTE

Storage requirements vary depending on climatic environment, length of storage and equipment. For storage periods of three months or longer, contact manufacturer for specific instructions. Improper storage could damage equipment and would result in non-warranty covered restoration of non-warranty covered product failures.

When storing the pump up to three months rotate the shaft for several revolutions at least once per month to coat the ball bearings with lubricant, retard oxidation and corrosion, and prevent possible false brinelling.

The motor ball bearings should be prepared for storage according to the motor manufacturer’s instructions, in the motor manufacturer’s maintenance manual, which should come with the motor.

For shipment and long-term storage purposes the pump ball bearing shall be fogged once every 30 days during storage with a rust retardant compatible with the oil used in the system to prevent rusting.

A pump which is made of iron or steel that sits in extreme heat, high humidity, or full or partially full of water over 30 days will rust and will most likely seize. If the pump rusts and/or seizes, a complete overhaul and repair may be necessary to refurbish the pump.

Consider a unit to be in storage when:

1. It has been delivered to the job site and is waiting to be installed.
2. It has been installed but operation is delayed pending completion of construction.
3. There are long (30 days or more) periods between operating cycles.
4. The plant (or department) is shut down for periods of longer than 30 days.

Measures to be taken for prolonged shutdown of installed pumping unit. If the pumping unit remains installed a periodic check of operation is in order to make sure that the pump is always ready for instant start-up and to prevent the formation of deposits within the pump and the pump intake area. Start up the pumping unit regularly once a month for a short time (approximately 5 minutes) during prolonged shutdown periods. Prior to operation check run ensure that there is sufficient liquid available for operating the pump.

Interim Storage (Indoors)/ Preservation. When the unit is temporarily put into storage, only the wetted low alloy must be preserved. Commercially available preservatives can be used for this purpose. Please observe the manufacturer’s instructions for application/removal.

The unit/pump should be stored in a dry room where the atmospheric humidity is as constant as possible.

If stored outdoors, the unit and crates must be covered by waterproof material to avoid any contact with humidity.

Protect all stored goods against humidity, dirt, vermin and unauthorized access!

All openings of the assembled unit components are closed and must only be opened when required during installation.

All blank parts and surfaces of the pump are oiled or greased (silicone-free oil and grease) to protect them against corrosion.

VII. INSTALLATION.

A. LOCATION. The pump assembly should be located in an area that will permit periodic inspection and maintenance. Head room and access should be provided and all units should be installed in a dry location with adequate drainage.

The pump assembly should be installed as close to the fluid as possible. A short, direct suction pipe can be used to keep suction losses at a minimum. If possible, locate the pump so fluid will flow by gravity to the suction opening. The discharge piping should be direct with as few elbows and fittings as possible. The total Net Positive Suction Head Available (NPSHA), which includes the suction lift and pipe friction losses, must be greater than the Net Positive Suction Head Required (NPSHR) by the pump.

B. HANDLING.



WARNING

If the pumping unit slips out of the sling arrangement, it may cause injury to personnel and/or damage to the pumping unit.



CAUTION

Use a hoist with adequate lifting capacity.

Do not pick up the complete unit by the motor or the pump shafts or motor lifting eyes.

Moving the unit requires proper preparation and handling. Always make sure that the pump or the pumping unit remains in a horizontal position while being moved and cannot slip out of the transport suspension arrangement. Use a sling for pumps without baseplates, refer to Figure 2. To lift a horizontal mounted unit, a hoist or suitable lifting device should be attached to each corner of base structure, refer to Figure 3. The individual motor may be lifted using proper eyebolts provided by the manufacturer, but these should not be used to lift the assembled unit.

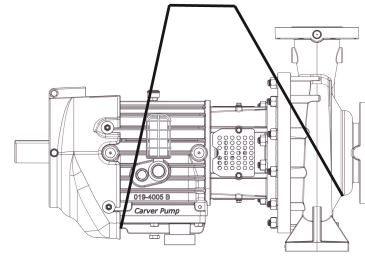

Figure 2. Sling Position for Moving Pump

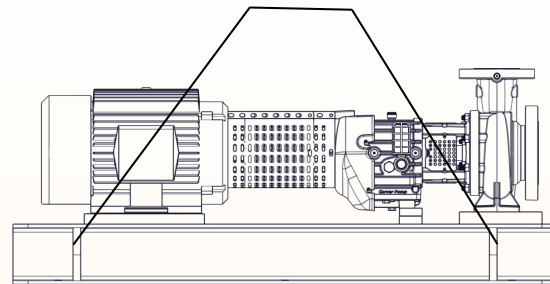

Figure 3. Sling Position for Moving Pumping unit

C. FOUNDATION. Make sure that the concrete foundation has set firmly before placing the unit on it. Its surface must be truly horizontal and even. The foundation bolts must be inserted in the base holes. The foundation should be 3 to 6 inches wider and longer than the base, have a level surface, and be of sufficient mass to prevent vibration and form a permanent rigid support for the unit. The best foundations are concrete with anchor bolts of adequate size embedded in the foundation in pipe sleeves having an inside diameter 2-1/2 times larger than the bolt diameter. This will allow for accurate positioning of the unit. Keep the concrete surface clean, yet rough.

Hydraulic Institute (HI) recommends a foundation capable of absorbing vibration at least five times the weight of the pumping unit and to form a permanent, rigid support for the base plate. Consequently, maintaining the pump to driver alignment is important for a flexible coupled unit, refer to Figure 6. A concrete foundation on a solid base is recommended. Use foundation bolts of the proper size embedded into the concrete. A pipe sleeve larger in diameter than the bolt should be used. This allows movement for final positioning of the bolts. Refer to Figure 4, Grouting and Foundation Bolting.

As soon as the pump and driver, mounted on a base, is placed on the foundation, remove the coupling guard and disconnect coupling halves.

D. LEVELING OF UNIT. When the pump is supplied complete with motor and base, the unit is assembled at the factory. Lower unit onto foundation, positioning base structure so anchor bolts are aligned in middle of holes in base.

The base should be supported on either rectangular metal blocks with shims or on metal wedges having a small taper. The support pieces should be placed close to the foundation bolts. Refer to Figure 4, Grouting and Foundation Bolting. Place supports directly under the part of the base, which carries the greatest weight. Space the supports closely enough to provide uniform support of the base. Adjust the metal supports or wedges until the shaft is level. Check suction and discharge flanges of the pump by means of a level. Make corrections, as necessary, by adjusting the supports or wedges under the base.



Do not attempt to straighten the base by using the anchor bolts.

If the base has leveling screw, the base should be supported by the provided leveling screws. Refer to Figure 5; adjust the leveling screws until provided base milled leveling pads are true in both the axial and transverse directions. Verify that the pump and driver shafts are level. Check coupling faces, as well as, suction and discharge flanges of the pump for horizontal or vertical positioning by means of a level. Make corrections, as necessary, by adjusting the leveling screws on the base.

E. GROUTING. After the pumping unit has been leveled and the alignment is correct, grout the unit to the foundation using a high-grade, non-shrinking grout. Proceed grouting using the following procedure:

Prepare concrete foundations, anchor bolts and leveling screws according to individual instructions covering these items.

1. Wax forms heavily with at least three coats of paste wax. Forms must be substantial and well braced. All corners, joints, bottoms must be sealed with silicone caulk for water tightness. All forms should have a 45° chamfer strip installed to prevent stress risers.
2. Anchor bolt-free length must be wrapped with duct seal or electricians plastic tape to prevent grout from contacting the bare metal. Grout sticking to the anchor bolt will prevent the elongation necessary to develop the hold-down force. Failure to do this will result in broken anchor bolts.
3. Leveling screws must be greased to permit removal prior to the final torque.
4. Do not use shim packs as a leveling device unless it is planned to remove them prior to final torque application.
5. Leveling screw pads should be a minimum of 1/2" thick with minimum diameter of 3". Corners of pad must be rounded to approximately 1/8" radius to prevent stress cracking. Set leveling screws on the chipped concrete surface. Set the pad with quick set cement or Resin Repair Compound. With jacking bolt pads secure and level, set and level base with leveling screws.
6. The underside of the standard factory steel base plate was painted with and should only require proper cleaning. If the base must be sandblasted, prepare the contact faces to SSPC-SP 6 Spec. If base cannot be set within 24 hours of blasting, the underside must be coated with a compatible Rust Inhibitive Primer. Tighten foundation bolts loosely. Allow the grout to fully cure before firmly tightening the foundation bolts.

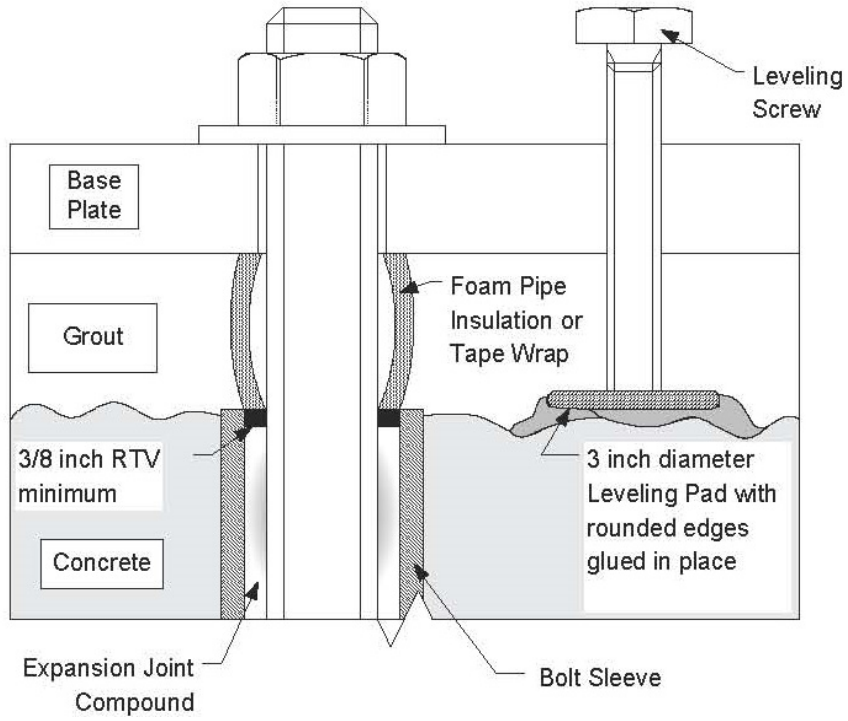
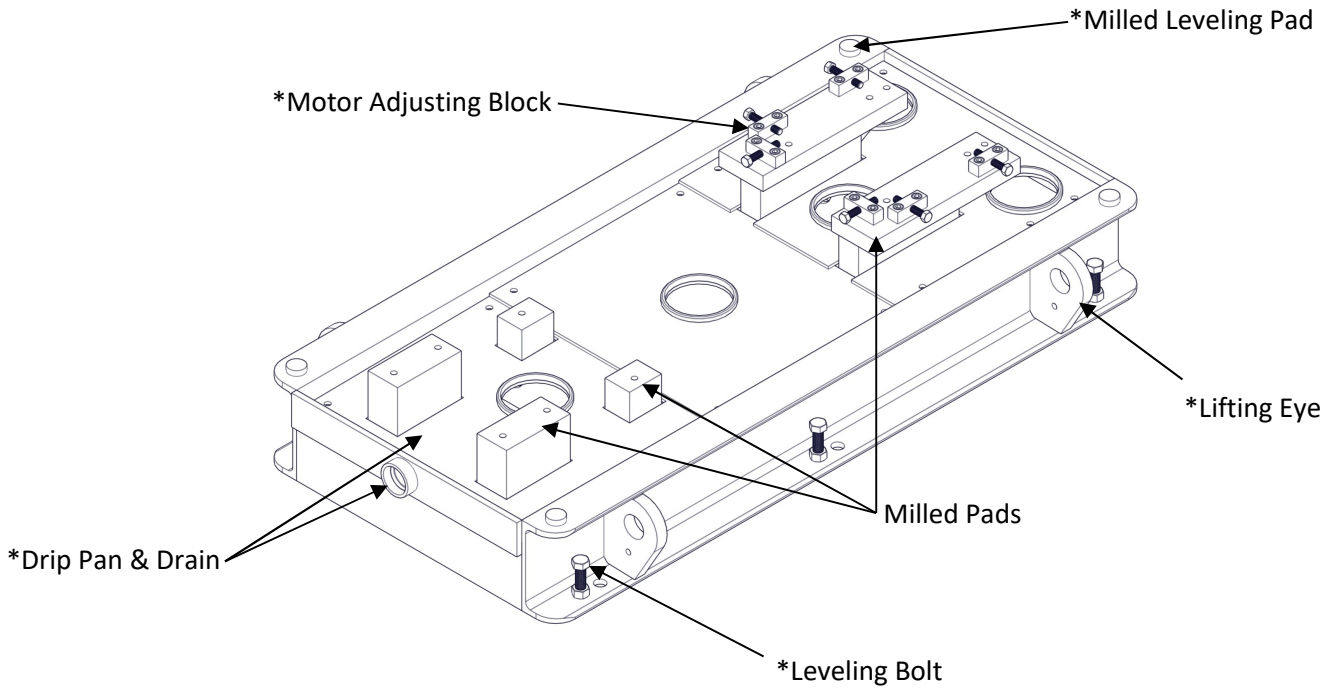

Figure 4. Grouting and Foundation Bolting



*Not on all Bases

Figure 5. Unit Leveling

F. COUPLING ALIGNMENT. The pump and motor are connected by a coupling. The base aligns the pump and motor. No further alignment is necessary unless the pump or motor were removed from the base or if there was not a base purchased with the unit then the following is how to check the coupling alignment. The coupling should NOT be reconnected until the alignment has been completed.

NOTE

Refer to coupling manufacturer’s manual for instructions regarding shaft alignment and recommended installation limits.

Soft Foot – The equipment must rest flat on its base. If one or more feet of the pump or motor are shorter, longer, or angled in some way to prevent uniform contact (a condition commonly known as “soft foot”) it must now be corrected.

To improve the life of the coupling, the shafts must be aligned to minimize deflection of the flexing elements. Shaft alignment is required in the axial, parallel, and angular directions, with each of these values not to exceed the recommended installation limits. Shaft alignment can be measured using various established methods, including Laser Alignment, Reverse Dial Indicator, and Rim and Face.

The motor and pump shafts must be accurately aligned as any misalignment can cause damage to the coupling, motor, or pump. When the shafts are in correct alignment, the coupling hubs will be on a common axis, concentric with each other, and at the correct distance apart. If the coupling hubs are misaligned, it is general practice to adjust the driver to the pump. Insert full

shims under the feet or supports of the motor and tighten fastening bolts until correct alignment is achieved.

1. Move the pump or motor to achieve acceptable alignment. When properly aligned, the disc packs will be centered and approximately parallel to their mating flange faces and the flexing elements will have little visible waviness when viewed from the side.

NOTE

Refer to the coupling manufacturer’s manual for recommended installation limits for Parallel, Angular, and Axial alignment.

2. The “Parallel Misalignment” value (P) is the offset between the centers of the hubs, as shown in Figure 6.
3. When the Parallel Offset is measured by rotating the hubs in unison with dial indicators as shown in Figure 6, the Total Indicator Reading (TIR) should be divided by (2) to calculate (P).
4. It should be noted that parallel offset measured on the hub surfaces includes misalignment of the equipment shafting plus any variation (TIR) in the hubs. This may be helpful to consider during problem solving for alignment difficulties.
5. The “Angular Misalignment” value is the maximum difference between the measurements X and Y taken at opposite ends of the hub flanges, as shown in Figure 6.

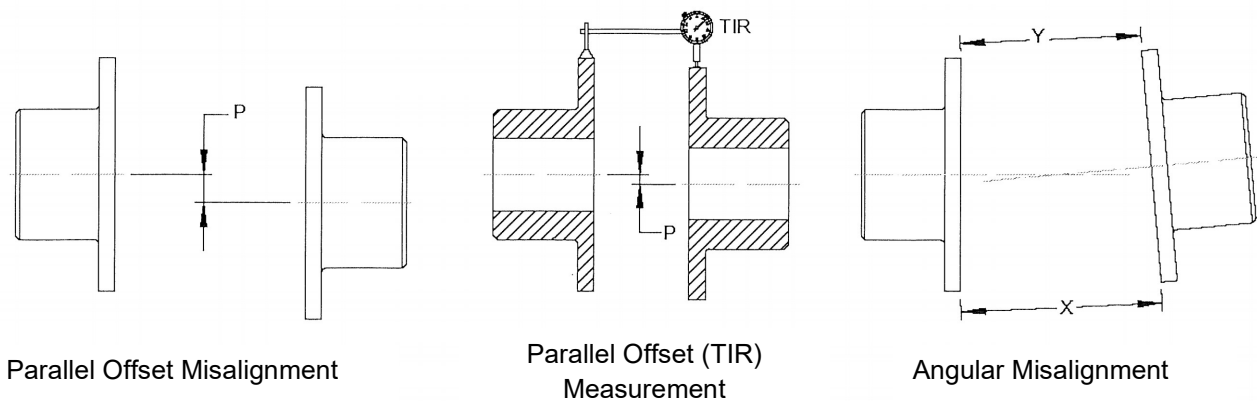

Figure 6. Coupling Alignment

G. PRE-INSTALLATION PROCEDURES.

1. Complete Section VII, Paragraph D.
2. Rotate the pump by hand. Check for any mechanical hesitation, binding or any acoustically transmitted signals from the pump. Hand rotation should be smooth and silent. Install the pump to foundation bolting and tighten to the system torque values. The pump should be rotated frequently during the procedure to tighten down the pumping unit.
3. After the pumping unit has been completely tightened down to the foundation, confirm that there is no binding.
4. Connect the piping.

H. PIPING. All piping should be independently supported near the pump so that pipe strain will not be transmitted to the pumping unit.



All piping connections must be made with the pipe in a freely supported state. Do not apply vertical or side pressure to align the piping with the pump flange.

Before connecting suction, discharge, and auxiliary piping, check to see that the piping is absolutely clean internally. Any debris in the piping will be drawn into the pump passageways and can cause extreme damage. The diameters of the suction and discharge lines must be equal to the diameters of the pump suction and discharge nozzles.

The pump is shipped with flange covers to protect flange faces and to prevent foreign matter from entering the pump. Flange covers should remain intact until suction and discharge piping are connected to pump flanges.

The suction pipe must be air tight. Suction lift lines shall be laid with a rising slope toward the pump and suction headlines with a downward slope towards the pump to avoid air pockets which will impair pump operation.

The discharge pipe should be as direct as possible using a minimum number of valves to reduce pipe friction losses.

Never use a straight taper (concentric) reducer in a horizontal suction line because air pockets may form in the top of the reducer and the pipe. Use an offset (eccentric) reducer instead.

It is recommended to install a check valve and closing valve in discharge line and closing valve in suction line,

depending on the type of plant and pump. The check valve, between the pump and valve, protects pump from water hammer and prevents reverse rotation in the event of power failure. Closing valves are used in priming, starting, and pump shut down. Pump must never be throttled by use of a valve in the suction line.

Thermal expansions of the pipeline must be compensated by appropriate measures so as not to impose any extra loads on the pump exceeding the permissible pipeline forces and moments. Refer to Table 4 for permissible forces and moments.

The coupling should be realigned after installing piping or when hot service units are at the final operating temperature. Refer to Section VII, Paragraph F for coupling alignment.

I. AUXILIARY PIPING CONNECTIONS AND GAUGES. In addition to primary piping connections, the pump may require other connections such as gauges or drains. All these lines and gauges should now be installed. Refer to vendor mechanical seal drawing for seal line connections to the cartridge mechanical seal.

J. MOTOR. See motor vendor's manual for motor information and information on connecting to the power supply.



Connection to the power supply must be affected by a trained electrician only. Check available main voltage against the data on the motor rating plate and select appropriate start-up method.

K. DIRECTION OF ROTATION. Correct pump rotation is indicated by an arrow on the pump. The standard direction of rotation, viewed from the motor end, is clockwise.

VIII. OPERATION.

A. PRE-START CAUTIONS.



Before activating the pumping unit, check to make sure there are no personnel working on the unit. Serious injury or death to personnel could result if the unit is activated while being worked on.

1. Before starting or operating the pump, read this entire manual, especially the following instructions.
2. Observe all caution or danger tags attached to the equipment.



Pumps are shipped without oil and should be filled with oil before starting the pumping unit. Operation of the unit without proper lubrication can result in overheating of the ball bearings, ball bearing failures, pump seizures and actual breakup of the equipment, exposing operating personnel to injury.

3. Fill bearing frame with oil (refer to Section X, Paragraph A and Table 7). Pumps are shipped with no oil in the bearing frame. If ball bearings are oil mist lubricated, turn on system, wait for proper oil quantity and check monitoring system.



Never run the pump dry. Close running fits within the pump are liquid lubricated. Dry running will result in pump seizure or damage.

4. Before starting the pump, fill the volute and suction line with liquid. The pump may be primed by using an ejector or vacuum pump.
5. Before starting a mechanical seal pump equipped with external flush lines, turn on mechanical seal water, and confirm the mechanical seal water has sufficient pressure and flow.
6. Check final alignment of pump and driver. Both shafts must turn freely by hand. If necessary, check coupling alignment.

7. Jog starter switch on motor to check that the direction of rotation agrees with the arrow on the pump.
8. Before starting the pump, install closed guards around all exposed rotating parts.
9. If excessive vibration or noise occurs during operation, shut the pump down and rotate shaft by hand. If excessive vibration or noise continues, consult a Carver representative.

B. PRIMING. Dry running a centrifugal pump can result in extensive damage and possible seizing. It is, therefore, imperative that the pump be primed prior to initial start-up and that prime must be maintained through subsequent start-stop cycles.

The priming procedure is different for positive and negative suction head systems. Follow the procedure listed below.

Positive Suction Head:

1. Open the vent on the highest point on the pump volute.
2. Open all suction valves.
3. Allow liquid to flow from vent hole until all air bubbles are vented. Then close the vent.
4. The pump is now primed.

Negative Suction Head:

1. Install an ejector or vacuum pump on the vent at the highest point on the volute.
2. Close the discharge valve.
3. Open the suction valve.
4. Start the ejector or vacuum pump.
5. Allow liquid to flow until a continuous flow is exhausted from ejector. Then close the valve to the vent.
6. The pump is now primed.

C. STARTING THE PUMP.



DO NOT operate pumping unit against a closed discharge system. If pump has any chance of seeing operation against a closed system, a bypass system allowing a minimum design flow should be installed. This bypass will be satisfactory for short periods of operation. For extended periods of operation the bypass should be sized for the minimum continuous flow required by the pump. Refer to Section VIII, Paragraph E for minimum/maximum flow calculation.

1. Confirm pumping unit is ready to start. Complete Section VIII, Paragraphs A and B.
2. If unit is equipped with mechanical seal cooling lines, turn on mechanical seal cooling water.
3. Fully open the suction valve.
4. Open discharge valves slightly, about 1 to 1 ½ turns if pump is being started for the first time or from being turned off for overhaul. Start the pump.
5. Slowly open discharge valves and adjust pressure and flow to the appropriate operating conditions. Refer to pump nameplate and system operating procedures for design point condition.

D. TURBINE APPLICATIONS. For turbine applications, consult your local distributor or a representative from Carver Pump Company.

E. MINIMUM/MAXIMUM FLOW CALCULATION. Unless otherwise specified in the characteristic curves or on the data sheets, the following applies

Q_{min}	=	$0.1 \times Q_{opt}$	for short operation
Q_{min}	=	$0.3 \times Q_{opt}$	for continuous operation
Q_{max}	=	$1.1 \times Q_{opt}$	for 2-pole operation
Q_{max}	=	$1.25 \times Q_{opt}$	for 4-pole operation
Q_{opt}	=	optimum efficiency	

The data above refers to water and water-like liquids. However, if the physical properties of the fluids handled are different from water, the calculation formula below must be used to check if an additional heat build-up may lead to a dangerous temperature increase at the pump surface. If necessary, the minimum flow must be increased.

$$T_o = T_f + \Delta T$$

$$\Delta T = \frac{g * H}{c * \eta} * (1 - \eta)$$

c	Specific heat	[J / kg K]
g	Acceleration due to gravity	[m/s ²]
H	Pump head	[m]
T _f	Temperature of fluid handled	[°C]
T _o	Temperature of casing surface	[°C]
η	Pump efficiency at duty point	[-]
Δ T	Temperature difference	[°C]

F. OPERATING CHECKS.

1. Check for undue vibration or noise. If any occurs and does not stop within a short period of time, turn off the pump. For determination of the cause and its remedy refer to Troubleshooting in Section IX or consult Carver Pump Company.
2. Check and record flow and pressure readings. The flow and pressure readings should be within the operating system guidelines and similar to number stamped on the pump nameplate.
3. Check and record ball bearing temperature according to the following steps, if resistance temperature detector (890E) or equal is not installed. Ball bearing temperature should not exceed 190° F (87° C).
 - a. Remove plug (552C) on bearing frame (19).
 - b. Measure and record ball bearing temperatures under where plug (552C) was located.
 - c. Reinstall plug (552C) on bearing frame (19).
4. Check and record power input to the motor.
5. Check for leakage at mechanical seals.

G. STOPPING THE PUMP.

1. If the pump is being stopped for overhaul, slowly close the discharge valve. Otherwise leave discharge valves set at condition.
2. Stop the pumping unit in accordance with the directions on the electrical power supply.

3. Tagout and lockout power to motor according to OSHA Standard 1910.147.
4. Close discharge and suction valves and any auxiliary fluid lines.
5. The pumping unit is now off.

H. INDEFINITE SHUTDOWN.



WARNING



When pump is handling hazardous fluid, extreme care must be taken to ensure safety of personnel when attempting to drain pump and piping before disconnecting the pumping unit. Suitable protection devices should be used and/or protective clothing should be worn.

Relubricate ball bearings. Remove casing plug to drain volute. Drain all piping if there is a possibility of liquid freezing. Provide pump and driver with a protective cover.

IX. TROUBLESHOOTING OPERATING PROBLEMS.

If you have followed the installation and starting procedures outlined in this manual, the pump should provide reliable service and long life. However, if operating problems do occur; significant time and expense can be saved if you refer to Table 5 to eliminate the most common causes of those problems.

Immediate action to be taken before proceeding with corrective actions in Table 5 is to stop the pump, refer to Section VIII, Paragraph G.

Table 5. Pumping Unit Troubleshooting

SYMPTOM	PROBABLE CAUSE	CORRECTIVE ACTION
Failure to deliver liquid.	<ol style="list-style-type: none"> 1. Discharge head above shutoff. 2. Check valve stuck or improperly installed. 3. Impeller or suction line clogged. 4. Incomplete priming or venting of pump or piping. 5. Valves are not fully open. 6. Excessive wear of internal parts. 	<ol style="list-style-type: none"> 1. Check pump rating against actual head condition. 2. Adjust and/or reverse valve. 3. Inspect suction line and impeller. Clean as necessary. 4. Vent piping again carefully and prime pump. 5. Open valves and if necessary, lock valves open to prevent accidental closure. 6. Disassemble pump and replace worn parts.
Excessive power consumption.	<ol style="list-style-type: none"> 1. Head lower than rating: trying to pump too much liquid or operating at end of performance curve. 2. Specific gravity or viscosity of liquid is too high. 3. Mechanical defects such as binding rotating elements. 4. System head lower than design condition. 5. Incorrect impeller diameter. 	<ol style="list-style-type: none"> 1. Adjust pressure flow. 2. Check liquid temperature and adjust as necessary. 3. Check for excessive pipe strain. Check foundation bolting. Replace defective parts. 4. Adjust system head. Trim impellers to actual condition. 5. Replace impeller or trim impeller to correct diameter. Consult with Carver Pump before trimming impellers.

Table 5. Pumping Unit Troubleshooting - Continued

SYMPTOM	PROBABLE CAUSE	CORRECTIVE ACTION
Insufficient discharge or flow.	<ol style="list-style-type: none"> 1. Discharge head above shutoff. 2. Air or gases in liquid. 3. Impeller or suction partially clogged. 4. Wrong direction of rotation. 5. Specific gravity or viscosity of liquid is too high. 6. Incorrect impeller diameter. 	<ol style="list-style-type: none"> 1. Check pump rating against actual head condition. 2. Adjust and/or redesign suction system. Add liquid to system. 3. Inspect suction and impeller and clean as necessary. 4. Reverse direction of rotation. 5. Check liquid temperature and adjust as necessary. 6. Replace impeller or trim impeller to correct diameter. Consult with Carver Pump before trimming impeller.
Vibration excessive.	<ol style="list-style-type: none"> 1. Foundation bolting loose. 2. Coupling halves not properly oriented relative to each other. 3. Impeller partially blocked. 4. Wrong rotation. 5. Insufficient foundation. 6. Pipe strain. 7. Coupling key to motor or coupling key to pump is not correct length. 8. Motor improperly balanced. 	<ol style="list-style-type: none"> 1. Torque bolting to proper values. 2. Adjust coupling halves system relative to match marks. 3. Inspect impeller and clean as necessary. 4. Adjust direction of rotation. 5. Stiffen foundation as necessary. 6. Modify piping as necessary. 7. Replace with key of correct length. 8. Balance motor.
Oil leak.	<ol style="list-style-type: none"> 1. Loose connection. 2. Defective deflector seal. 3. Loose or defective gasket. 	<ol style="list-style-type: none"> 1. Tighten connectors. 2. Replace deflector seal. 3. Tighten bolting and/or replace gasket.
Ball bearing temperature excessive.	<ol style="list-style-type: none"> 1. Lubrication, insufficient lubrication. 2. Defective ball bearing. 3. Pump/driver shafts are misaligned. 4. Piping causes pump to “warp”. 	<ol style="list-style-type: none"> 1. Lubricate according to Section X, Paragraph A. 2. Replace ball bearing. 3. Check coupling alignment. 4. Ensure piping transmits no stress to pump. Alter piping layout, if necessary. Realign pump and driver shafts.

X. MAINTENANCE.

Generally, the pump does not need continuous supervision. The pump should always run quietly and smoothly, without vibration. To ensure such operation, the following maintenance schedule should be applied at regular intervals during operation of the pump. Occasional visual checks are recommended. Data should be recorded periodically for each pump to keep track of maintenance which has been performed and to note operational problems. A sample maintenance record sheet is provided for this purpose at the front of this manual.



Regular inspection and service are essential for safe operation of the pump in ATEX applications.

NOTE

Parts marked with * are options or vary by pump or bearing frame size.

Daily Inspection:

- Visually inspect unit.
- Check ball bearing temperatures.
- Check for leakage at mechanical seal.
- Check that oil level is at center of bullseye, if applicable. If equipped with a constant level oiler*, check oil level in the constant level oiler and refill as required. Insure proper oil mist if applicable.

Weekly Inspection:

- Check power (amps) readings.
- Check pump discharge pressure. Prescribed operating discharge pressure should never drop below 90 percent of design point pressure.
- Check vibration on pump and driver ball bearings. Vibration should NOT exceed 1.5 of overall displacement (unfiltered) peak to peak mils (0.001") at 3600 RPM and 3.0 of overall displacement (unfiltered) peak to peak mils (0.001") at 1750 RPM.

Monthly Inspection:

- Check foundation bolts.
- If necessary, grease coupling, but DO NOT over grease.
- Check foundation bolts.

Semi-annual Inspection:

- Check for coupling alignment due to settling of foundation.
- If stand-by pumps are installed, it is advisable to operate pumps on a rotational system to give each pump a periodic duty. This ensures that stand-by pumps will have periodic operation and always be in good condition for instant start-up.

300 Hours

- The first oil change should be carried out after 300 hours of operation.

3000 Hours

- After the first oil change at 300 hours subsequent oil changes should be affected at intervals of 3000 hours of operation



25000 Hours - Overhaul

- For pump overhaul, complete Section XI, Service and Repair.

A. LUBRICATION OF PUMP BALL BEARINGS.

Ball Bearings (16 and 18). The radial ball bearing (16) and the thrust ball bearings (18) are lubricated by oil in the bearing frame. The thrust ball bearings are installed back-to-back. Replace the ball bearings when disassembling the pumping unit for mechanical seal service.



WARNING



Pumps are shipped without oil and should be filled with oil before starting the pumping unit. Operation of the unit without proper lubrication, oil too low or over full can result in overheating of the ball bearings, ball bearing failures, pump seizures and actual breakup of the equipment, exposing operating personnel to injury.

To change oil, unscrew bearing frame pipe plug (550) in bearing frame (19) and drain oil. Flush bearing frame with petrol or benzol. Slowly rotate the shaft by hand during flushing. Use correct oil viscosity for ambient temperature, fluid temperature and altitude. Start with ISO 32 and monitor oil condition. Replace bearing frame pipe plug and fill the bearing frame with oil (refer to Table 6 for oil recommendations) through the breather vent (890B). Fill bearing frame until oil can be seen in the center of the bullseye sight.

Table 6. Oil Recommendations

Manufacturer	ISO Grade 22, 32, 68
Royal Purple	Synfilm
Texaco	Regal R&O
Phillips	Magnus Oil
Exxon	Teresstic

***Constant Level Oiler.** If equipped with a constant level oiler, fill reservoir with oil, place thumb over spout, invert and screw reservoir into upper casting. Allow reservoir to empty, filling the bearing frame (Figure 7). Several fillings of the reservoir may be required before the actual oil level is reached. To avoid adding too much oil, never finish filling oil in bearing frame (19) through the vent breather (890B) at top of the bearing frame. Never use lower casting only as a fill spout, always fill thru reservoir. When oil level is reached, no more oil will run out of the reservoir bottle. Use constant level oiler's glass sight to check oil level in bearing frame. When oil level is reached tighten the three setscrews on the side of the upper oiler. The constant level oiler (890A) should be topped up as required during operation.

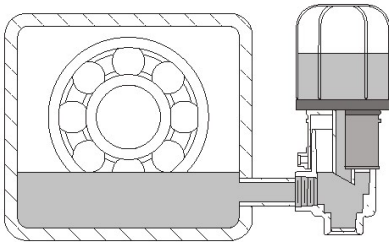

Figure 7. Constant Level Oiler

***Oil Mist.** The Maxum OH1 comes equipped with appropriate connections for the installation of an oil mist system by the customer if oil mist lubrication is desired. Oil mist lubrication provides the greatest protection against contamination by dirt and water. The top port of the bearing frame (19) is plugged for oil mist lubricated ball bearings. The plug (550) in the bottom of the bearing frame should be removed so that condensed oil vapor can be drained and/or removed from the bearing frame.

B. LUBRICATION OF MOTOR BALL BEARINGS.

See motor manufacturer's instructions to be sure motor ball bearings are properly lubricated.

C. TORQUE VALUES.

Refer to Table 7, Recommended Torque Values. Clean and properly lubricate threads and bearing face of the fastener to

obtain the proper fastener loading from these torque values. Fasteners should be tightened evenly and in stages. Refer to your torque wrench manual for the proper use of your wrench.

Table 7. Recommended Torque Values (ft-lbs)

Bolt Size	Material		
	Composite	Steel (or otherwise noted)	316 Stainless Steel
UNC			
1/4"-20	5	5	7
5/16"-18	11	11	12
3/8"-16	18	18	21
1/2"-13	33	39	45
5/8"-11	54	83	97
3/4"-10	80	105	132
7/8"-9	109	160	203
1"-8	144	236	300
Impeller Nut - 30 ft-lbs while holding the coupling end of the shaft.			

Table 8. Recommended Equipment

Tools	Materials	Test Equipment
Spanner Wrench Rawhide or Wood Mallet Wooden Wedge Allen Wrench Set Socket, Open, & Box Wrench Set Vice Grips Torque Wrench Bearing Heater Bearing Puller	Oil O-ring Lubricant	Coupling Alignment Gauges Volt-Amp Meter

XI. SERVICE AND REPAIR.

Refer to Figures 8 through 13, the exploded views and Figure 16 to locate the pump parts by item number and parts list.

A. PREPARATIONS FOR DISASSEMBLY OF PUMP.

During disassembly, match mark parts so they can be replaced in their original position. All parts should be thoroughly cleaned or replaced with new, if necessary. Sealing faces should be perfectly clean. Carver Pump Company recommends that all O-rings and shims are only used once.

The back pull-out design of the pump enables the pump to be disassembled without disconnecting the piping or removing the pump casing from the base. When the pump is fitted with spacer coupling, the driver can also remain bolted on the base.



CAUTION



Factory authorized parts must be used to safely maintain your Carver Pump.

NOTE

To avoid damage to O-rings, check to make sure all parts are free of sharp edges or burrs.

Close suction and/or discharge valves. The pump casing should be cooled down to ambient temperature. The casing must be empty and not under pressure.

After prolonged operation, components may not be easily removed from shaft. In such instances, rust solvent may be used and suitable extracting tools applied wherever possible. DO NOT use force under any circumstances. Refer to Table 8, Recommended Equipment, for proper tooling during disassembly and assembly. Refer to appropriate sectional drawing for location of parts followed by an item number. Assemble the pump in accordance with accepted rules of engineering practice. Coat individual components with a suitable lubricant before assembling. Assembly of unit should be performed on a clean, flat surface.

While assembling the pumping unit, Carver Pump Company recommends that the following parts be replaced with new:

- O-rings / Gaskets
- Shims
- Ball Bearings
- Deflector seals
- Mechanical seals

Prepare the pumping unit for disassembly using the following list:

1. Read this entire section and study the applicable sectional or exploded view drawing and parts list before disassembling the pump.



DANGER

Before attempting to disassemble the pump, the electrical power supply to the driver must be locked and tagged in the “OFF” position to prevent injury or death to personnel servicing the pumping unit.

2. Stop the pumping unit; refer to Section VIII, Paragraph G.



CAUTION



When pump is handling hazardous fluid, extreme care must be taken to ensure safety of personnel when attempting to drain pump and piping before disconnecting the pumping unit. Suitable protection devices should be used and/or protective clothing should be worn.

3. Disconnect piping, gauge lines, and auxiliary connections, as necessary.
4. Drain casing (1) by opening casing drain blind flange (*524) or removing pipe plug (552D). If necessary, flush pump to remove corrosive or toxic pumpage. Close casing drain blind flange or reinstall pipe plug when fluid is completely drained. Collect and dispose of corrosive or toxic material appropriately.
5. Remove bearing frame pipe plug (550) in bearing frame (19) and drain oil. If a constant level oiler (890A*) provides lubrication for ball bearings, drain oil from the bearing frame by removing bearing frame pipe plug at bottom of bearing frame. If bearings are mist lubricated, drainage of bearing frame is continuous.

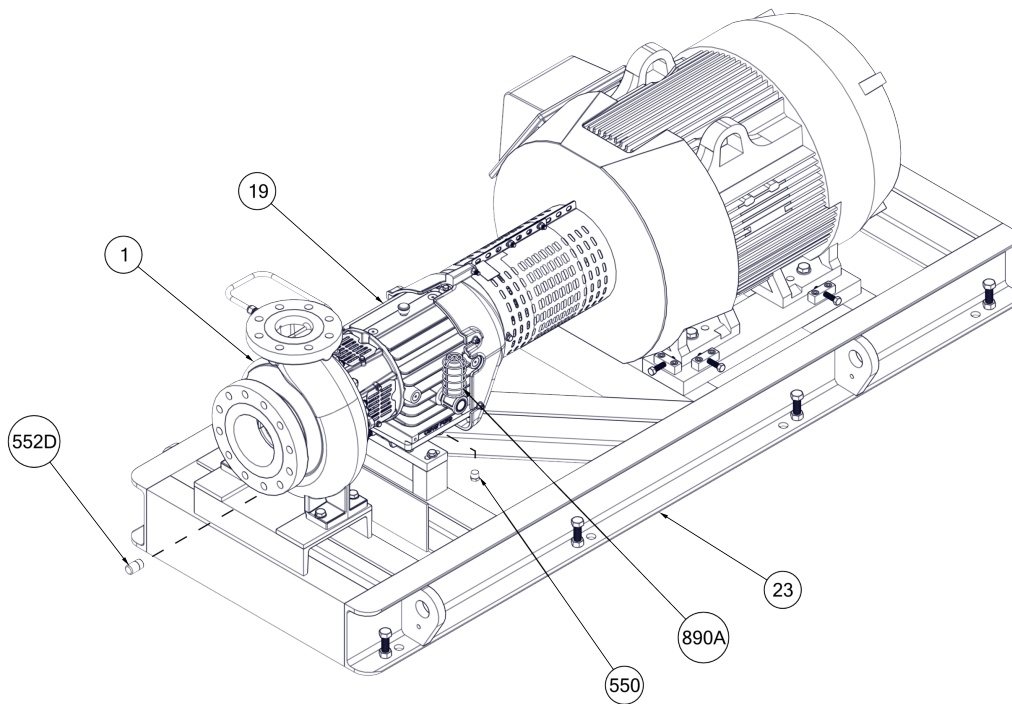

NOTE

Parts marked with * are options.

Parts marked with ** are not shown.

Item Number	Description
1	Casing
19	Bearing Frame
23	Base
*73B**	Gasket - Casing Drain Flange
*524**	Blind Flange – Casing Drain
550	Pipe Plug – Bearing Frame Oil Drain
552D	Pipe Plug – Casing Drain
*800H**	Hex Head Bolt– Casing Drain Blind Flange
*830H**	Hex Nut – Casing Drain Blind Flange
*840H**	Lock Washer – Casing Drain Blind Flange
890A	Oiler

Figure 8. Draining the Pumping Unit

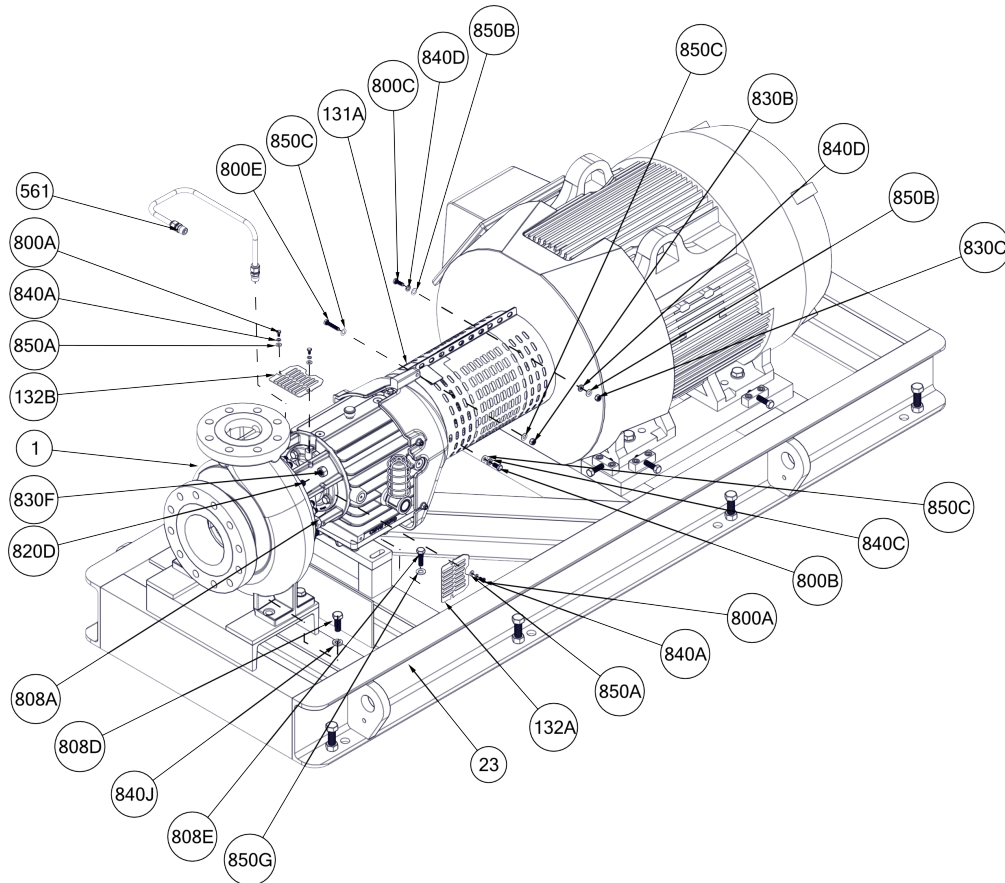

Item Number	Description	Item Number	Description
1	Casing	808E	Hex Head Bolt – Bearing Frame to Base
23	Base	820D	Stud – Back Cover to Casing
*73A**	Gasket – Auxiliary Piping	820E**	Stud – Back Cover to Casing
131A	Coupling Guard	830B	Hex Nut - Coupling Guard/Fan Shroud
132A	Splash Guard – Bearing Frame/Mechanical Seal	830C	Hex Nut - Coupling Guard
132B	Splash Guard/Cutout – Bearing Frame/Mechanical Seal	*830E**	Hex Nut – Piping Plan Flange/Casing
*135**	Orifice, Pan Handle	830F	Hex Nut – Back Cover/Casing
*515**	Flange, Piping Plan	840A	Lockwasher – Splash Guard Bearing Frame/Mechanical Seal
*561	Male Connector	840C	Lockwasher – Coupling Guard/Fan Shroud
800A	Hex Head Bolt – Splash Guard Bearing Frame/Mechanical Seal	840D	Lock Washer – Coupling Guard
800B	Hex Head Bolt – Coupling Guard/Fan Shroud	840J	Lockwasher – Casing to Base
800C	Hex Head Bolt – Coupling Guard	850A	Washer – Splash Guard Bearing Frame/Mechanical Seal
800E	Hex Head Bolt – Coupling Guard/Fan Shroud	850B	Washer – Coupling Guard
*800G**	Hex Head Bolt - Flange	850C	Washer – Coupling Guard/Fan Shroud
808A	Hex Head Bolt – Backcover	850G	Washer – Bearing Frame to Base
808D	Hex Head Bolt – Casing to Base		

***Piping Plan 11 Shown **Not Shown *Options

Figure 9. Preparation to Remove Back Pull-Out

6. (Refer to Figure 9) Remove capscrews (800A), flatwashers (850A) and lockwashers (840A) and remove splash guards (132A and 132B).
7. Remove hex nuts (830B and 830C) from hex bolts (800C and 800E). Remove lockwashers (840D), flat washers (850B and 850C) and bolts (800C and 800E) from coupling guard (131A). Remove bolts (800B), washers (850C), and lockwashers (840C) from fan shroud/coupling guard. Remove coupling guard and disconnect coupling (42) halves, refer to Figure 10. Remove coupling spacer between coupling halves. The coupling halves may stay attached to the pump and motor shaft.

10. Otherwise remove hex nuts (830F) from studs (820D and 820E) fastening casing (1) to back cover (11). Use forcing bolts (808A) to loosen rabbet fit of back cover and casing. Pull rotating element back from casing and take it to a suitable work area, refer to Section VII, Paragraph B for handling of pump refer to Figure 11. Casing wear ring (7A*) will remain in the casing.

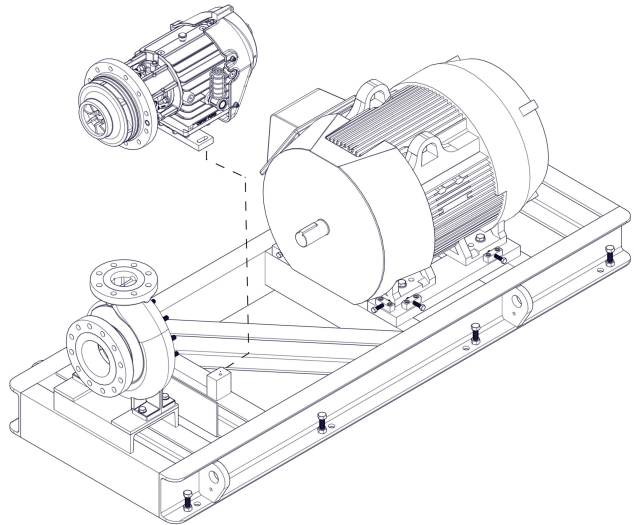
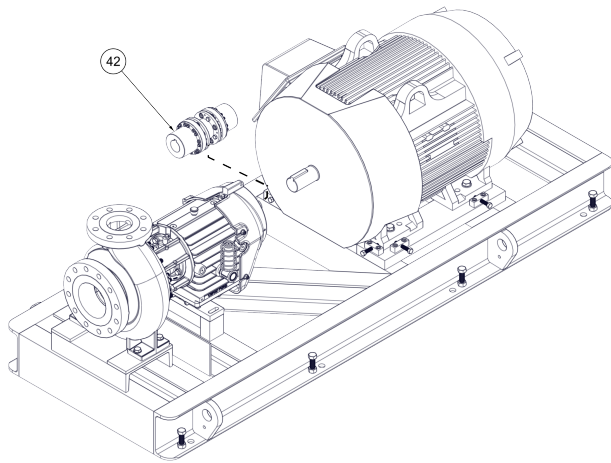

Figure 11. Remove Back Pull-Out

Item Number	Description
42	Coupling

Figure 10. Remove Coupling

8. If pumping unit is being serviced for performance reasons and the complete pump needs to be removed, remove bolts (808D) and lockwasher (840J) from casing (1) foot holding casing to base (23). Remove bolts (808E) and washers (850G) from bearing frame (19) foot holding bearing frame to base. Note any shims between bearing frame foot and base.
9. If complete pumping unit was removed from base (23) for service take it to a suitable work area, refer to Section VII, Paragraph B for handling of pump.

B. DISASSEMBLY OF PUMP. The instructions that follow are an aid for properly trained personnel to service your Carver Pump. Refer to Figures 8 through 13, the exploded views and Figure 16 to locate the pump parts by item number and parts list. If a specific sectional assembly drawing exists for a particular job then that drawing should be referred to for service work. Read this entire section before disassembling the pump.

The back pull-out design of the pump enables the pump to be disassembled without disconnecting the piping or removing the pump casing from the base. When the pump is fitted with optional spacer coupling, the driver can also remain bolted on the base.

NOTE

Parts marked with * are options that vary by pumping unit and bearing frame size.

Refer to Section II for Safety precautions before disassembling pump.

After completion of dismantling, all parts should be thoroughly cleaned or replaced by new ones if necessary. All gaskets and sealing faces should be perfectly clean. When cutting new gaskets, make sure they are exactly the same thickness as the old ones.



CAUTION

Use a hoist with adequate lifting capacity; refer to Section VII, Paragraph B.



When pump is handling hazardous fluid, extreme care must be taken to ensure safety of personnel when attempting to drain pump and piping before disconnecting the pumping unit. Suitable protection devices should be used and/or protective clothing should be worn.

NOTE

Mark or number each component while dismantling according to sequence.

The individual components should be unscrewed or removed.

1. Complete Section XI, Paragraph A before continuing with disassembly.

NOTE

If complete pumping unit was removed from system complete this step, if not, proceed to step 3.

2. Loosen lock nut (*834) and unscrew discharge nozzle (*224) from casing (1). Remove O-ring (*700D) from discharge nozzle and discard. (Refer to Figure 17)
3. Remove acorn nut (24) or inducer (*246) and impeller washer (28). Pull impeller (2 or *3) from shaft (6). Impeller key (32A) may come off with impeller.

NOTE

Refer to mechanical seal vendor instructions for proper mechanical seal removal procedure.

4. For cartridge mechanical seals (90), reinstall seal clip and loosen setscrews holding the cartridge seal sleeve to shaft (6).
5. Remove hex nut (830D) and lockwasher (840E) from stud (820C) holding back cover (11) to bearing frame (9). Loosen back cover with forcing bolt (808A) and remove back cover.
6. Wear ring (7A) will remain in back cover (11) unless replacement is necessary. Throttle bushing (*63) may come off with back cover, if still on shaft (6) remove throttle bushing. Remove O-ring (*700B) from back cover and discard. Remove casing gasket (*73D) from back cover and discard.
7. Remove hex nut (830G) and washer (*850F) from stud (820F) and remove mechanical seal (90) from back cover (11).



CAUTION

Handle inboard bearing deflector (*716) with care. Mishandling could damage faces of inboard bearing isolator.

NOTE

It is not normally necessary to remove the inboard seal deflector (*716).

8. Remove capscrews (800D) fastening inboard bearing cap (35) to bearing frame (19). Remove inboard bearing cap and inboard seal deflector (*716) from shaft (6). Remove gasket (73C) from between inboard bearing cap and bearing frame and discard.
9. If necessary, remove inboard bearing seal deflector (*716) from inboard bearing cap (035). If equipped, remove inboard magnetic seal deflector (*716) from inboard bearing cap.
10. Remove pump coupling half and pump coupling key (32C).

NOTE

Parts marked with * are options or vary by pump or bearing housing size.

Parts marked with ** are not shown.

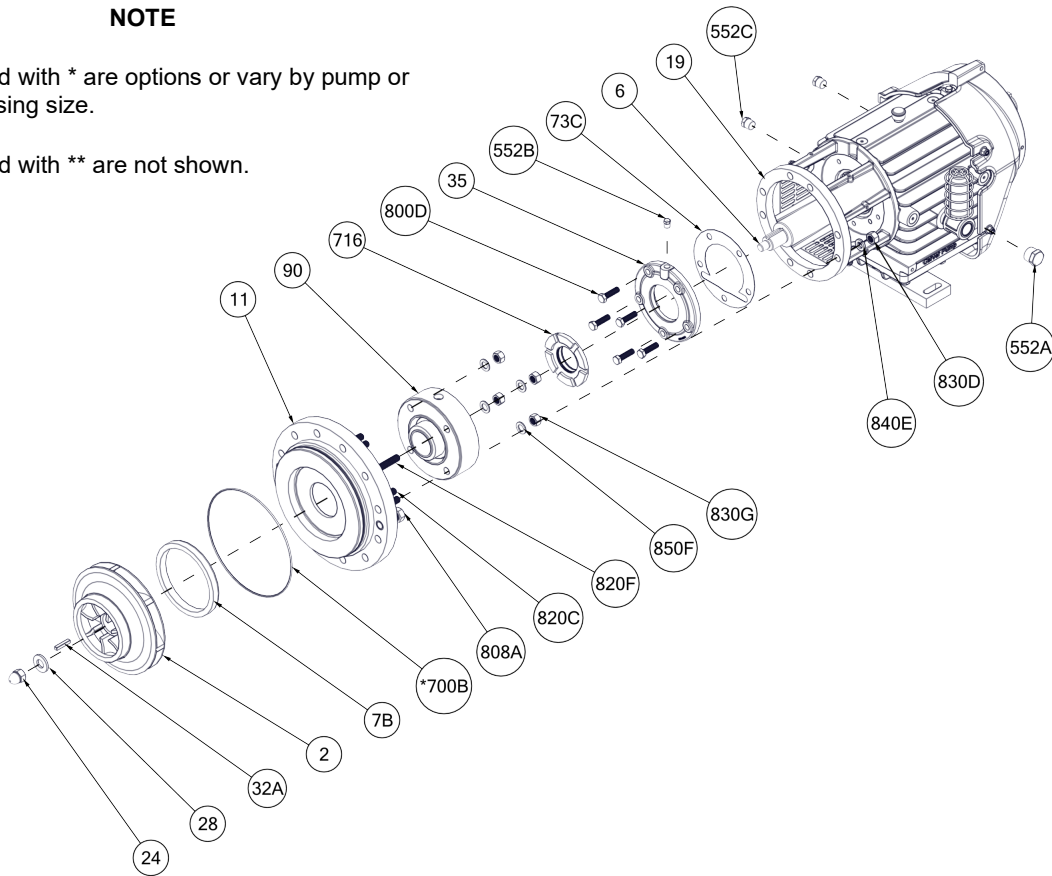

Item Number	Description	Item Number	Description
2	Impeller	552C	Pipe Plug – Bearing Frame/Bearing Temperature
6	Shaft	*700B	O-ring – Back Cover/Casing
7B	Wear Ring – Back Cover	716	Seal, Deflector – Bearing Cap Inboard
11	Back Cover	800D	Hex Head Bolt – Bearing Cap, Inboard/Bearing Frame
19	Bearing Frame	808A	Bolt – Back Cover
24	Acorn Nut – Impeller	820C	Stud – Back Cover/Bearing Frame
28	Impeller Washer	820F	Stud – Back Cover/Mechanical Seal
32A	Key, Impeller	830D	Hex Nut – Bearing Frame/Back Cover
35	Bearing Cap, Inboard	830G	Hex Nut – Mechanical Seal
73C	Gasket – Bearing Frame/ Bearing Cap	840E	Lock Washer – Bearing Frame to Back Cover
90	Mechanical Seal, Cartridge	*850F	Washer – Mechanical Seal
552A	Pipe Plug – Bearing Frame	864B**	Setscrew – Wear Ring/Back Cover
552B	Pipe Plug – Bearing Cap		

Figure 12. Back Pull-Out, Inboard Exploded View

11. Refer to Figure 13, remove locknuts (837) and washers (850D) from studs (820A) fastening fan shroud (131B) to bearing frame (19) and remove fan shroud. Take **note** of any washers on inside of fan shroud on studs for spacing.
12. Loosen hose clamp (590) and remove frame cooling fan (40) from shaft (6). Remove fan key (32B) from shaft.
13. Remove hex nut (830A) and lockwasher (840B) from stud (820B), remove outboard bearing cap (37) and outboard seal deflector (715) from shaft 6).
14. Remove O-ring (700A) from bearing frame (19) and discard.



Handle outboard seal deflector (*715) with care. Mishandling could damage faces of outboard seal deflector.

NOTE

It is not normally necessary to remove the outboard magnetic seal deflector (*715).

15. If necessary, remove outboard seal deflector (*715) from bearing cap (37).

16. Remove shaft (6) (with radial and thrust bearing assemblies) from outboard end of bearing frame (19).
17. Un-crimp tang on bearing lockwasher (69). Remove bearing locknut (22) and bearing lockwasher.

NOTE

It is recommended that ball bearings removed from the shaft be replaced.

18. If necessary, pull thrust ball bearing (18) and radial ball bearing (16) from shaft (6).
19. If required for maintenance loosen flinger setscrew (*871) and remove oil flinger (*60) from shaft (6).

NOTE

Parts marked with * are options or vary by pump or bearing housing size.

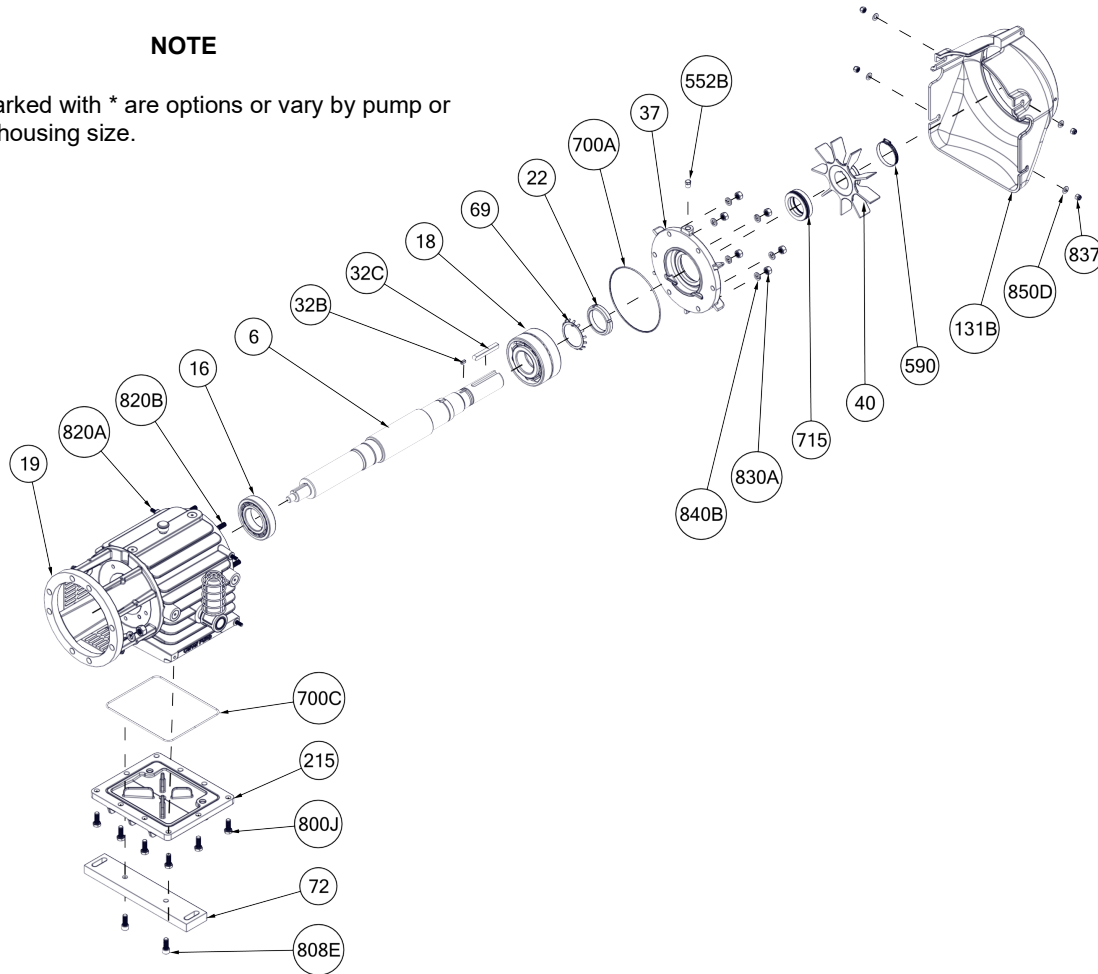

Item Number	Description	Item Number	Description
6	Shaft	552B	Pipe Plug – Bearing Cap
16	Radial Bearing	590	Hose Clamp – Bearing Frame Cooling Fan
18	Thrust Bearing	700A	O-ring – Bearing Cap, Outboard/Bearing Frame
19	Bearing Frame	700C	O-ring – Oil Pan/Bearing Frame
22	Bearing Locknut	*715	Seal, Deflector – Bearing Cap, Outboard
32B	Key, Fan	800J	Hex Head Bolt – Oil Pan/Bearing Frame
32C	Key, Coupling	808E	Bolt – Bearing Frame Foot/Bearing Frame
37	Bearing Cap, Outboard	820A	Stud, Bearing Frame/Fan Shroud
40	Fan, Bearing Frame Cooling	820B	Stud – Bearing Frame/Bearing Cap, Outboard
69	Bearing Lock Washer	830A	Hex Nut – Bearing Cap, Outboard
72	Bearing Frame Foot	837	Locknut, Fan Shroud
131B	Fan Shroud	840B	Lockwasher –Bearing Cap, Outboard
215	Oil Pan	850D	Washer – Fan Shroud/Bearing Frame

Figure 13. Back Pull-Out, Outboard Exploded View

C. PARTS INSPECTION.

1. All parts should be thoroughly cleaned with a suitable solvent or replaced with new ones if necessary.
2. All sealing faces should be perfectly clean. All gaskets, O-rings, seals, and locking devices with a nylock feature are replaced with new if disturbed from position.
3. Check shaft (6) for runout, scratches, grooves, or any possible damage. Touch up scratches and grooves with a polishing cloth and inspect for remaining grooves or deep scratches. A bent or excessively damaged shaft should be replaced.
4. Inspect casing (1) and back cover (11) for pitting, scoring, and erosion. The inside of the casing and back cover should be free of any pits or grooves. The maximum allowable depth is 1/8" (3mm). Replace the casing or back cover if any of these defects are present.
5. Inspect mechanical seal (90). Repair or replace mechanical seal that is extremely worn or damaged.
6. Inspect impeller, fan and coupling keys (32A, 32B and 32C) for distortion and push fit into keyways. The keys should be square on all four edges. They should fit without having to be forced. The keys should not rock in keyway. Replace keys or shaft if necessary.
7. Inspect tubing for kinking. Replace kinked tubing.
8. If the impeller (2) shows excessive wear due to erosion or pitting, so that performance cannot be restored, it must be replaced. If a new impeller is installed, check to make sure that it is balanced and of the correct trim.

9. Check the wear ring clearances as follows:
 - a. Measure outside diameter of front impeller (2) wearing surface in three places.
 - b. Measure inside diameter of casing wear ring (*7A) in three places.
 - c. If difference between the high reading of the inside diameter of the casing wear ring (*7A) and the low reading of the outside diameter of the impeller (2) wearing surface exceeds double the maximum clearances given in Table 9, replace the volute wear ring according to Section XI, Paragraph E.
 - d. Measure outside diameter of back impeller (2) wearing surface in three places.
 - e. Measure inside diameter of the back cover wear ring (7B) in three places.
 - f. If difference between the high reading of the inside diameter of the back cover wear ring (7B) and the low reading of the outside diameter of the back impeller (2) wearing surface exceeds double the maximum clearances given in Table 9, replace the back cover wear ring according to Section XI, Paragraph E.
10. Check diameter of the discharge nozzle (*224) against the diameter listed on the nameplate and confirm they match. If they do not, replace the discharge nozzle to the correct diameter that matches the nameplate.

Table 9. Factory Wear Ring Clearance (Inches)

Pump Size	Factory Standard Diametric Clearance (inch)	
	Minimum	Maximum
AA- 1½ x 1 x 6	0.012	0.017
AB - 2 x 1½ x 6	0.015	0.020
AC- 3 x 1½ x 6	0.014	0.019
AD - 3 x 2 x 6	0.016	0.021
AE - 4 x 3 x 6	0.016	0.021
BA - 1½ x 1 x 8	0.012	0.017
BB - 2 x 1½ x 8	0.012	0.017
BC - 3 x 1½ x 8	0.014	0.019
BD - 3 x 2 x 8	0.016	0.021
BE – 4 x 3 x 8	0.017	0.022
BF - 6 x 4 x 8	0.017	0.022
CA – 2 x 1½ x 10	0.012	0.017
CB - 3 x 1½ x 10	0.015	0.020
CC - 3 x 2 x 10	0.016	0.021
CD - 4 x 3 x 10	0.017	0.022
CE - 6 x 4 x 10	0.018	0.023
CF - 6 x 6 x 10	0.018	0.023
CG - 8 x 6 x 10	0.019	0.024
DA - 2 x 1½ x 13	0.016	0.021
DB - 3 x 2 x 13	0.016	0.021
DC - 4 x 3 x 13	0.017	0.022
DD - 6 x 4 x 13	0.018	0.023
DE - 6 x 6 x 13	0.018	0.023
DF - 8 x 6 x 13	0.020	0.025
DG - 10 x 8 x 13	0.021	0.026
DH – 12 x 10 x 13	0.023	0.028
ED- 6 x 4 x 16	0.018	0.023
EA- 8 x 6 x 16	0.020	0.025
EB - 10 x 8 x 16	0.021	0.026
ED - 12 x 10 x 16	0.023	0.028
EC - 14 x 12 x 16	0.024	0.029
FA - 8 x 6 x 20	0.020	0.025
FB - 10 x 8 x 20	0.021	0.026
FC - 12 x 10 x 20	0.023	0.028
FD – 14 x 12 x 20	0.025	0.030

D. REASSEMBLY OF PUMP. The instructions that follow are an aid for properly trained personnel to assemble your Carver Pump. Refer to Figures 8 through 13, the exploded views and Figure 16, pump with base, to locate the pump parts by item number and parts list. If a specific sectional assembly drawing exists for a particular job, then that drawing should be referred to for

assembly. Refer to Table 7 for recommended torque values. Read this entire section before reassembling the pump. During reassembly, install parts as applicable.



CAUTION

During reassembly, install new locknuts, as they have a self-locking feature. Locknuts with a self-locking feature may not provide adequate security once disturbed from position.

During reassembly, install new O-rings, seal deflectors, and gaskets if disturbed from position. O-rings, seal deflectors and gaskets may have been damaged during disassembly.

During reassembly, Carver Pump recommends that the ball bearings be replaced if disturbed from position.

NOTE

If ball bearings were removed, proceed to step 1, if not removed proceed to step 4.

All parts should be thoroughly cleaned or replaced with new ones if necessary. All sealing faces should be perfectly clean, but do not scratch or alter surface finish on seal faces.

To ensure proper seating of bearing parts, rotate the ball bearing while clamping the parts.

Parts marked with * are options that vary by pumping unit and bearing frame size.



CAUTION

While installing back-to-back ball bearings, DO NOT unnecessarily hit ball bearings. If damage to ball bearings occurs, replace damaged ball bearings with new ball bearings.



After 25000 Hours of service replace the ball bearings.

1. If removed, press thrust ball bearings (18) on shaft (6). Secure thrust ball bearings (18) with bearing lock washer (69) and bearing locknut (22). Crimp tang of lock washer in grooves provided in bearing locknut.
2. If removed, install oil flinger (*60) on shaft (6) and tighten flinger setscrew (*871).
3. If removed, press radial ball bearing (16) on shaft (6).

4. Install shaft (6) (with radial and thrust bearing assemblies) from outboard end of bearing frame (19) in bearing frame. Seating the thrust ball bearings (18) in the bearing frame.
5. Install new O-ring (700A) in groove provided around outboard end of bearing frame (19).



CAUTION

Handle outboard seal deflector (*715) with care. Mishandling could damage faces of outboard seal deflector.

6. If removed, press outboard magnetic seal deflector (*715) into outboard bearing cap (37). Install outboard seal deflector in outboard bearing cap.
7. Reinstall outboard bearing cap (37) on shaft (6). Secure outboard bearing cap with lock washer (840B) and hex nut (830A) on stud (820B).
8. Install fan key (32B) in shaft (6). Reinstall frame cooling fan (40) over fan key on shaft, and secure with hose clamp (590).

NOTE

Washers (850D) are used inside fan shroud (131B) on studs (820A) for spacing of fan shroud. Number of washers should have been noted during disassembly.

9. Install washers (850D), noted during disassembly, on studs (820A). Install fan shroud (131B) on bearing frame (19) with washers and locknuts (837) on studs.



CAUTION

Handle inboard seal deflector (716) with care. Mishandling could damage faces of inboard seal deflector.

10. If removed, press inboard magnetic seal deflector (716*) into inboard bearing cap (35). Install inboard seal deflector (716) in inboard bearing cap.
11. Install gasket (73C) on inboard bearing cap (35). Install inboard bearing cap on shaft (6). Secure inboard bearing cap to bearing frame (19) with hex head bolts (800D).
12. Confirm back cover wear ring (7A) is in back cover (11). Install throttle bushing (63*) in back cover. Install O-ring (700B*) on back cover.

NOTE

Refer to mechanical seal vendor instructions for complete seal installation procedure.

13. Install mechanical seal (90) on back cover (11) with hex nuts (830G) and washers (850F*) on studs (820F). Tighten setscrews holding the cartridge seal sleeve to shaft (6) per manufacturer's instructions. Remove seal clip after mechanical seal installation is complete.
14. Install back cover (11) to bearing frame (19) with hex nut (830D) and lock washer (840E) on stud (820C).
15. Install impeller key (32A) in keyway on shaft (6).
16. Reinstall impeller (2) on shaft (6). Secure impeller with impeller washer (28) and impeller nut (24) or inducer (*246).
17. Install pump coupling key (46B) in shaft (6). Install coupling (42) half on shaft.



CAUTION

Use a hoist with adequate lifting capacity; refer to Section VII, Paragraph B.

18. Return assembly to installation site.
19. Confirm that forcing bolts (808A) are below the sealing surface of the back cover (11). Confirm casing wear ring (7) is in casing (1).
20. Install rotating element in casing (1). Secure back cover (11) to casing with hex nuts (830F) on studs (820D and 820E).
21. Rotate shaft (6) by hand to insure shaft rotates freely and no rubbing noises are present.
22. Install lock washer (840J) and hex head bolts (808D) holding casing (1) to base (23). Install washers (850G) and hex head bolts (808E) on bearing frame foot (72) holding bearing frame (19) to base.
23. Install shims (15) under bearing frame (19) foot. Check for soft foot between base (23) and bearing frame foot. If necessary, loosen hex nuts (830D) holding bearing frame (19) to back cover (11) to rotate bearing frame and/or adjust shims, as necessary to eliminate soft foot. Tightened hex nuts if loosened.
24. Rotate shaft (6) by hand to insure shaft rotates freely and no rubbing noises are present.
25. Refer to Figure 17, if discharge nozzle (*224) was removed from the casing (1), make sure that locknut (*834) is still attached to discharge

nozzle. Install O-ring (*700D) on discharge nozzle and install in casing. Tighten locknut to secure discharge nozzle to casing.

26. Install coupling (42) spacer. Reconnect coupling halves. Align coupling according to Section VII, Paragraph F.
27. Reinstall coupling guard. Secure coupling guard (131A) with washers (850B), lockwashers (840D), and hex nuts (830C), on bolts (800C and 800E). Secure coupling guard to fan shroud with bolts (800B), flatwashers (850C), and lockwashers (840C).
28. Reconnect piping, gauge lines, and auxiliary connections, as necessary. Confirm casing is secure to base.
29. Install seal guard (132A and 132B) on bearing frame (11). Secure seal guard with flatwashers (850A), lockwashers (840A), and capscrews (800A).



WARNING



Pumps should be filled with oil before starting the pumping unit. Operation of the unit without proper lubrication can result in overheating of the ball bearings, ball bearing failures, pump seizures and actual breakup of the equipment, exposing operating personnel to injury.

30. Fill bearing frame with oil (refer to Section X, Paragraph A and Table 6). If ball bearings are oil mist lubricated, turn on system, wait for proper oil quantity and check monitoring system.
31. Remove all tags from valves and switches.
32. Start pumping unit in accordance with Section VIII, Paragraph C.

E. REPLACEMENT OF WEAR RING. The pump has replaceable wear rings (*7 and 7A) inserted into the casing (1) and back cover (11). The clearance between the wear ring and impeller wearing surface will increase with wear. Internal leakage will result and pump performance will decrease. The allowable clearance and method of measurement is described in Section XI, Paragraph C.

NOTE

Parts marked with * are options that vary by pumping unit and bearing frame size.

Refer to Section II for Safety precautions before disassembling pump.

Casing Wear Ring (*7A).

The casing (1) must be removed from the base (23) to replace the casing wear ring. To replace the casing wear ring follow these steps:



CAUTION



When pump is handling hazardous fluid, extreme care must be taken to ensure safety of personnel when attempting to drain pump and piping before disconnecting the pumping unit. Suitable protection devices should be used and/or protective clothing should be worn.

1. Complete Section XI, Paragraph A before continuing with disassembly.
2. Remove impeller nut (24) and impeller washer (28). Pull impeller (2) from shaft (6). Impeller key (32A) may come off with impeller.
3. Disconnect suction and discharge piping. Remove hex head bolt (808D) and lock washer (840J) from casing (1) foot holding casing to base (23) to remove casing. Take casing and impeller (2) to a work area with access to machine shop equipment.
4. Remove the casing wear ring (*7A) from the casing (1). This can best be accomplished on a lathe.
5. Press the new casing wear ring (*7A) into the casing (1). The beveled edge of the casing wear ring is installed away from the impeller (2).
6. Secure the new casing wear ring (*7A) to the casing (1) by drilling and tapping three holes and installing wear ring set screws (864A**).
7. Place impeller (2) on an arbor and mount between centers in a lathe or a grinder. Indicate front outside impeller wearing surface to within 0.002 TIR maximum to be sure the arbor and impeller are running square.

NOTE

When replacing casing wear ring with the standard casing wear ring, (part number beginning with "00") machining in step 8 is not required. When replacing casing wear ring with the undersize casing wear ring (part number beginning with "US") machining in step 8 is required.

8. Turn the front outside wear ring surface of the impeller (2) until a 63 RMS or better finish is obtained.
9. Measure the outside diameter of the front impeller wearing surface and record this value. See measurement instructions in Section XI, Paragraph C.
10. Mount the casing (1) with new casing wear ring (*7A) installed in a lathe. Indicate female rabbet to within 0.002 TIR maximum.

NOTE

When replacing casing wear ring with the standard casing wear ring, (part number beginning with "00") machining in step 11 is not required. When replacing casing wear ring with the undersize casing wear ring (part number beginning with "US") machining in step 11 is required.

11. If replacing with an undersized casing wear ring, bore casing wear ring (*7A) to within the specified tolerance listed in Table 9 over the recorded size of the outside diameter of the front impeller wearing surface.
12. Reinstall casing (1) on base (23) and secure with hex head bolts (808D) and lock washer (840J) through foot of casing into base.
13. Reassemble pump. Refer to Section XI, Paragraph D, steps 15 through 29.

Back Cover Wear Ring (7B).



CAUTION



When pump is handling hazardous fluid, extreme care must be taken to ensure safety of personnel when attempting to drain pump and piping before disconnecting the pumping unit. Suitable protection devices should be used and/or protective clothing should be worn.

1. Complete Section XI, Paragraph B, steps 1 through 7 before continuing. Remove back cover (11) with back cover wear ring (7B) still installed and the impeller (2) to a work area with access to machine shop equipment.
2. Remove the back cover wear ring (7B) from the back cover (11). This can best be accomplished on a lathe.
3. Press the new back cover wear ring (7B) into the back cover (11). The beveled edge of the back cover wear ring is installed away from the impeller (2).
4. Secure the new back cover wear ring (7B) to the back cover (11) drilling and tapping three holes and installing wear ring set screws (864B**).
5. Place impeller (2) on an arbor and mount between centers in a lathe or a grinder. Indicate back outside impeller wearing surface to within 0.002 TIR maximum to be sure the arbor and impeller are running square.

NOTE

When replacing back cover wear ring with the standard back cover wear ring, (part number beginning with "00") machining in step 6 is not required. When replacing back cover wear ring with the undersize back cover wear ring (part number beginning with "US") machining in step 6 is required.

6. Turn the back outside wear ring surface of the impeller (2) until a 63 RMS or better finish is obtained.
7. Measure the outside diameter of the back impeller wearing surface and record this value. See measurement instructions in Section XI, Paragraph C.
8. Mount the back cover (11) with new back cover wear ring (7B) installed in a lathe. Indicate backside rabbet to within 0.002 TIR maximum.

NOTE

When replacing back cover wear ring with the standard back cover wear ring, (part number beginning with "00") machining in step 9 is not required. When replacing back cover wear ring with the undersize back cover wear ring (part number beginning with "US") machining in step 9 is required.

9. If replacing with an undersized back cover wear ring, bore back cover wear ring (7B) to within the specified tolerance listed in Table 9 over the recorded size of the outside diameter of the back impeller wearing surface.
10. Reassemble pump. Refer to Section XI, Paragraph D, steps 12 through 30.

F. **MOTOR.** The motor should be maintained in accordance with the manufacturer's instructions.

G. **CHECK VALVE.** If applicable, the check valve should be maintained in accordance with the manufacturer's instructions.

XII. PARTS LISTS AND DRAWINGS.

This section contains listings of parts and corresponding drawings. Table 10 notes the recommended spare parts for this pumping unit. Refer to Figures 8 through 13, the exploded views and Figure 16, Pump with Base, drawings for the location of parts identified by item numbers.

Table 10. Recommended Spare Parts List

Item Number	Description	Item Number	Description
2	Impeller	*73A**	Gasket, Auxiliary Piping
*3	Impeller, Low-Flow High-Head	*73B**	Gasket, Casing Drain Flange
*7A	Wear Ring	73C	Gasket, Bearing Frame/IB Bearing Cap
7B	Wear Ring	*73D**	Gasket, Casing
16	Radial Bearing	90	Mechanical Seal
18	Thrust Bearing	700A	O-Ring, OB Bearing Cap
22	Bearing Locknut	*700B	O-Ring, Back Cover -Casing
24	Acorn Nut, Impeller	700C	O-Ring, Oil Pan
28	Impeller Washer	*700D	O-Ring, Discharge Nozzle
32A	Key, Impeller	*715	Seal, Deflector - OB
32B	Key, Fan	*716	Seal, Deflector - IB
32C	Coupling Key - Pump	*834	Locknut, Discharge Nozzle
32D	Coupling Key - Motor	837	Locknut, Fan Shroud
69	Bearing Lock Washer		

*Parts are options that vary by pumping unit and bearing frame size. ** Not Shown

Item Number	Description
1	Casing
2	Impeller
6	Shaft
*246	Inducer

*Option

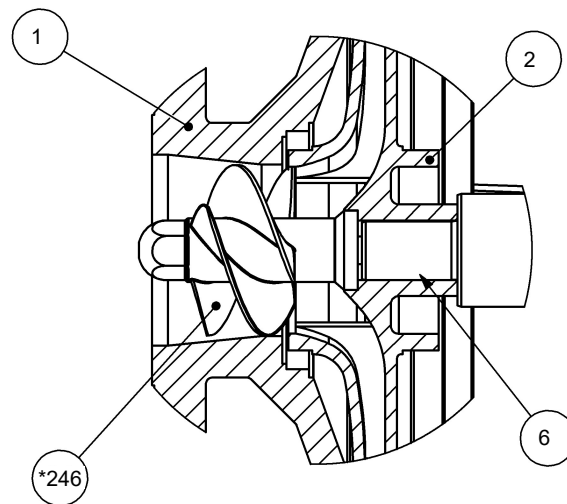

Figure 14. Inducer

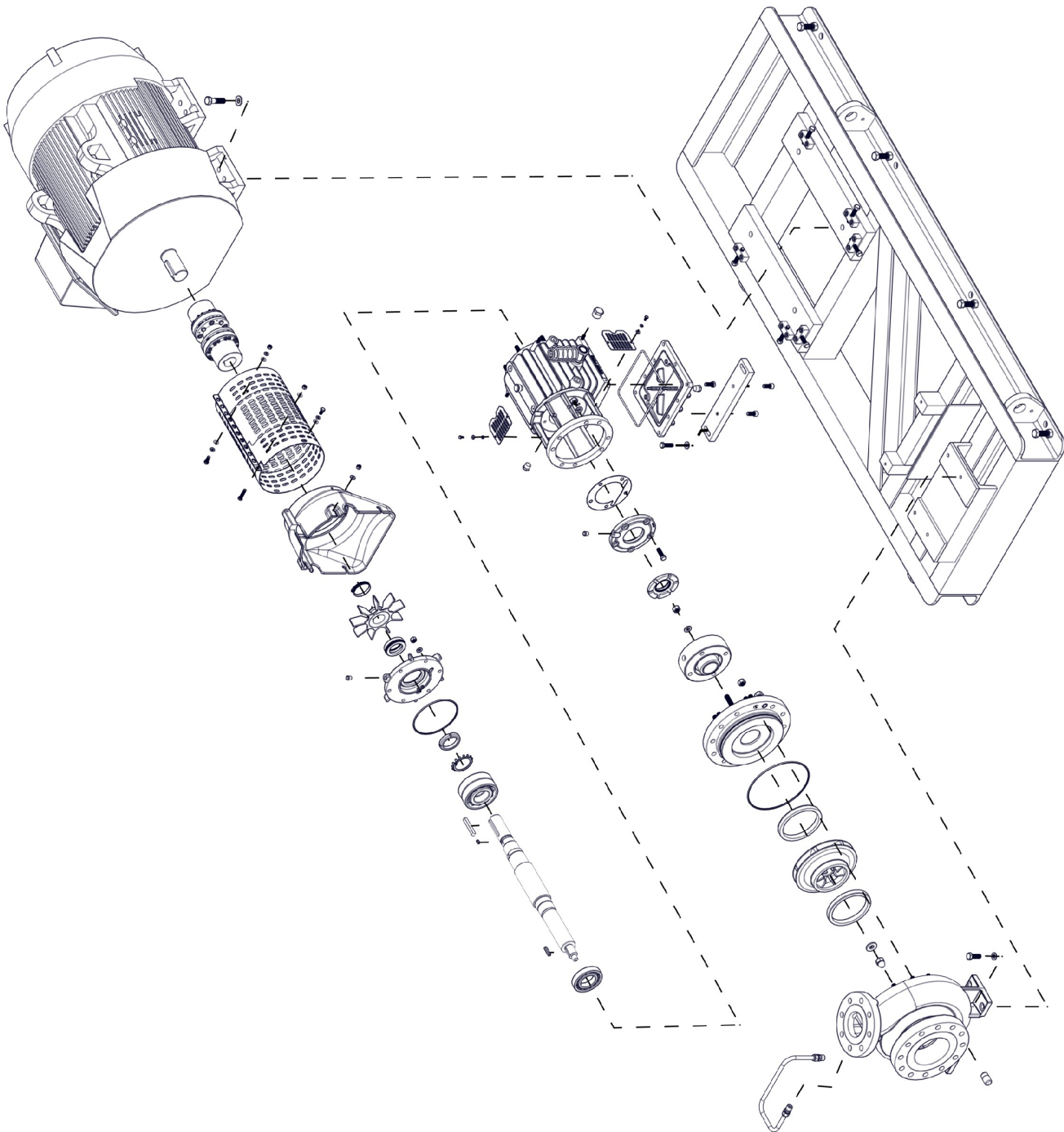

Figure 15. Exploded View of Complete Pump for Reference

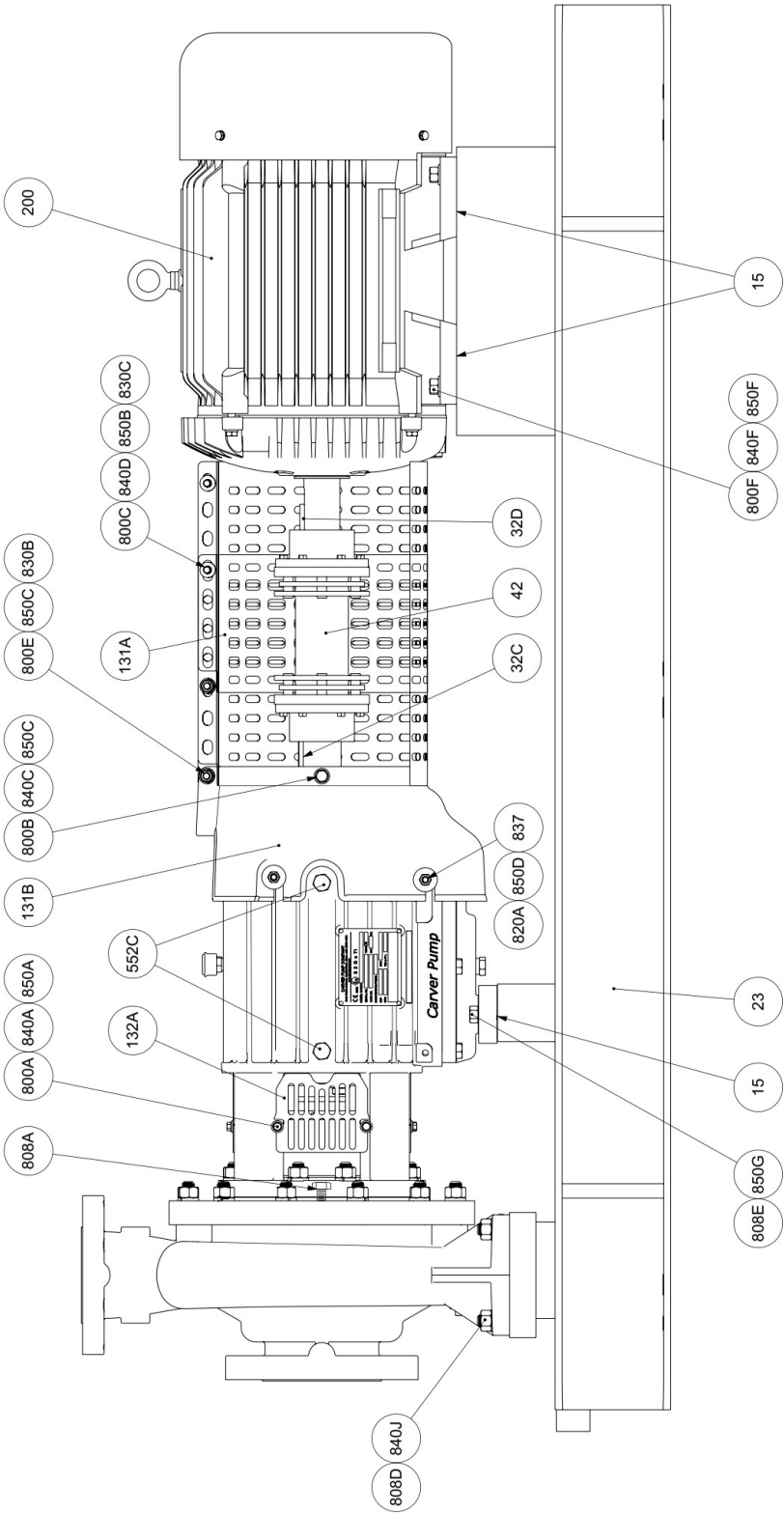
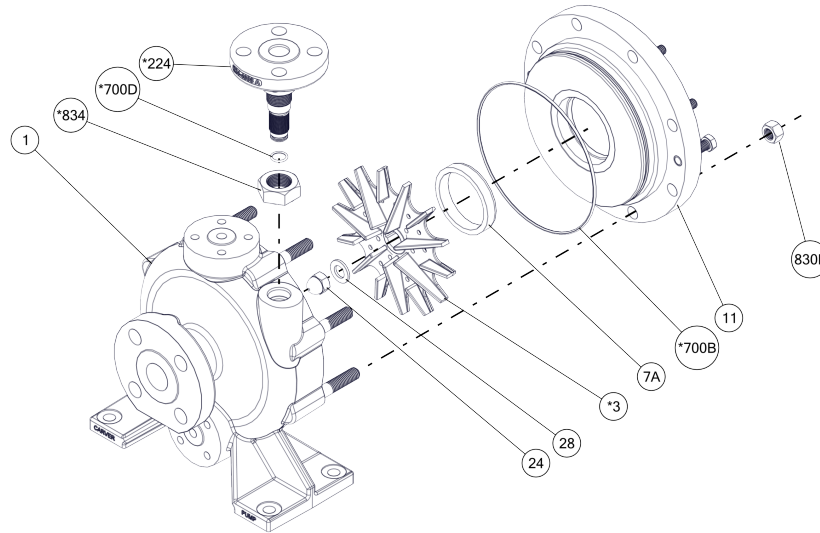

Figure 16. Pump with Base

Table 11. Parts List

Item Number	Description	Item Number	Description
1	Casing	700C	O-ring, Oil Pan/ Bearing Frame
2	Impeller	*700D	O-ring, Discharge Nozzle
*3	Impeller, Low-Flow High-Head	*715	Seal, Deflector – OB
6	Shaft	*715**	Seal, Deflector – OB, Magnetic
7A	Wear Ring – Casing	*716	Seal, Deflector – IB
7B	Wear Ring – Back Cover	*716**	Seal, Deflector – IB, Magnetic
11	Back Cover	800A	Hex Head Bolt – Splash Guard /Mechanical Seal
15	Shim	800B	Hex Head Bolt – Coupling Guard/Fan Shroud
16	Radial Bearing	800C	Hex Head Bolt – Coupling Guard
18	Thrust Bearing	800D	Hex Head Bolt – Bearing Cap, Inboard/Bearing Frame
19	Bearing Frame	800E	Hex Head Bolt – Coupling Guard/Fan Shroud
22	Bearing Locknut	800F	Hex Head Bolt – Motor/Base
23	Base	*800G	Hex Head Bolt – Flange (Piping Plan)
24	Acorn Nut, Impeller	*800H	Hex Head Bolt – Casing Drain Blind Flange
28	Impeller Washer	800J	Hex Head Bolt – Oil Pan Bearing Frame
32A	Key - Impeller	804	Bolt, Motor Adjusting Block/Base
32B	Key - Fan	808A	Bolt – Back Cover, Forcing
32C	Coupling Key - Pump	808B	Bolt – Motor Adjusting Block
32D	Coupling Key - Motor	808C	Bolt – Base Leveling Bolt
35	Bearing Cap, Inboard	808D	Bolt – Casing to Base
37	Bearing Cap, Outboard	808E	Bolt – Bearing Frame Foot/Bearing Frame
40	Fan, Bearing Frame Cooling	820A	Stud, Bearing Frame/Fan Shroud
42	Coupling	820B	Stud – Bearing Frame/Bearing Cap, Outboard
*60**	Oil Flinger	820C	Stud – Back Cover/Bearing Frame
*63**	Throttle Bushing	820D	Stud – Back Cover to Casing
69	Bearing Lockwasher	820E	Stud – Back Cover to Casing
72	Bearing Frame Foot	820F	Stud – Back Cover/Mechanical Seal
*73A**	Gasket, Auxiliary Piping	830A	Hex Nut – Bearing Cap, Outboard
*73B**	Gasket, Casing Drain Flange	830B	Hex Nut - Coupling Guard/Fan Shroud
73C	Gasket, Bearing Frame/ Bearing Cap	830C	Hex Nut - Coupling Guard
*73D**	Gasket, Casing	830D	Hex Nut – Bearing Frame/Back Cover
81	Motor Adjusting Block	*830E	Hex Nut – Piping Plan Flange/Casing
90	Mechanical Seal	830F	Hex Nut – Back Cover/Casing
131A	Guard, Coupling	830G	Hex Nut – Mechanical Seal
131B	Fan Shroud	*830H	Hex Nut – Casing Drain Blind Flange
132A	Guard, Splash – Bearing Frame/Mechanical Seal	*834	Locknut, Discharge Nozzle
132B	Guard, Splash – Bearing Frame/Mechanical Seal Cutout	837	Locknut, Fan Shroud
*135**	Orifice, Pan Handle	840A	Lockwasher – Splash Guard Bearing Frame/Mechanical Seal
*143**	Oil View Sight	840B	Lockwasher – Bearing Cap, Outboard
200	Electric Motor	840C	Lockwasher – Coupling Guard/Fan Shroud
215	Oil Pan	840D	Lockwasher – Coupling Guard
*224	Discharge Nozzle	840E	Lock Washer – Bearing Frame to Back Cover
226A**	Caution Label	*840F	Lock Washer – Motor to Base
226B**	Nameplate	*840H	Lockwasher – Casing Drain Blind Flange
226C**	Rotation	840J	Lockwasher – Casing to Base
*246	Inducer	850A	Washer – Splash Guard Bearing Housing/Mechanical Seal
*515**	Flange – Piping Plan	850B	Washer – Coupling Guard
*524**	Blind Flange - Casing Drain	850C	Washer – Coupling Guard/Fan Shroud
*536**	Reducer Bushing – Vent Breather	850D	Washer – Fan Shroud/Bearing Frame
*550	Pipe Plug – Bearing Frame Oil Pan	850E	Washer – Motor to Base
552A	Pipe Plug – Bearing Frame	*850F	Washer – Mechanical Seal
552B	Pipe Plug – Bearing Cap	850G	Washer – Bearing Frame Foot to Base
552C	Pipe Plug – Bearing Frame/Bearing Temperature	864A**	Setscrew – Wear Ring/Casing
552D	Pipe Plug – Casing Drain	864B**	Setscrew – Wear Ring/Back Cover
*552**	Pipe Plug – Mechanical Seal	*871**	Setscrew – Flinger
*561	Male Connector	890A	Oiler
590	Hose Clamp – Bearing Frame Cooling Fan	890B	Vent Breather
700A	O-ring – Bearing Cap, Outboard/Bearing Frame	*890D**	Vibration Sensor
*700B	O-ring, Back Cover -Casing	*890E**	Temperature Sensor

* Option ** Not Shown



Item Number	Description	Item Number	Description
1	Casing	*224	Discharge Nozzle
*3	Impeller, Low-Flow High-Head	*700B	O-Ring, Back Cover/Casing
7B	Wear Ring, Back Cover	*700D	O-Ring, Discharge Nozzle
11	Back Cover	830F	Hex Nut, Back Cover/ Casing
24	Acorn Nut, Impeller	*834	Locknut, Discharge Nozzle
28	Impeller Washer	864B**	Setscrew – Wear Ring/Back Cover

NOTE: Parts marked with * are options or vary by pump or bearing housing size. ** Not Shown

Figure 17. Wet End Low-Flow High-Head Option

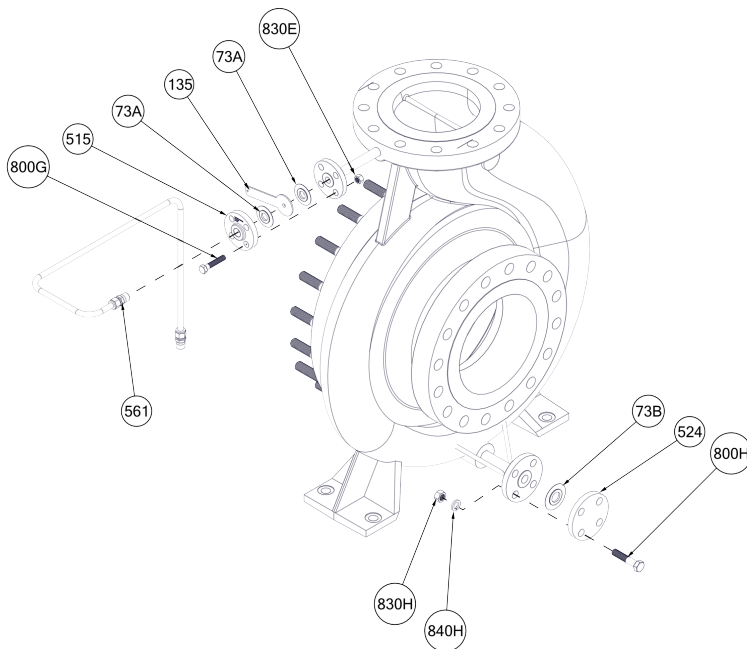

Item Number	Description
*73A	Gasket, Auxiliary Piping
*73B	Gasket, Casing Drain Flange
*135	Orifice, Pan Handle
*515	Flange, Piping Plan
*524	Blind Flange, Casing Drain
*561	Male Connector
*800G	Hex Head Bolt, Flange (Piping Plan)
*800H	Hex Head Bolt, Casing Drain Blind Flange
*830E	Hex Nut, Piping Plan Flange/Casing
*830H	Hex Nut, Casing Drain
*840H	Lockwasher, Casing Drain Blind Flange

NOTE: Parts marked with * are options or vary by pump or bearing housing size.

Figure 18. Flanged Drain and Discharge Option with Plan 11



CARVER PUMP™

Built for purpose

2415 Park Avenue, Muscatine, IA 52761
Phone: 563.263.3410 www.carverpump.com

**Maxum OH1 IOM
402 – 17.04.EN**