



NOV 2016

G2V Series–Vertical Cantilever, and Sump Pumps

Technical Specification Pages

Part Number: _____

Serial Numbers: _____

1.0 Overview.

The G2V Series is Carver's vertical pump line designed for moderate to high flow rates. It includes a cantilevered (G2C) and extended length, sump (G2S) versions.

All G2V pumps are provided with the wet end, support column, bearing frame, and motor mounting bracket as standard.

Standard options include: discharge piping (standard and oversized) with top plates to accommodate the discharge piping, 316 SS underliners (0.048" thickness) for contamination and corrosion protection, inlet tail pipes and suction strainers.

1.1 Basic Hydraulic Features.

Standard hydraulic features for the G2V Series program are shown in the table below.

Basic Hydraulic Features											
G2V Series Pump		General Design Features					Hydraulic Performance				
Basic Size	Ordering Code	*Bearing Frame Size (Motor Frame)	Max RPM	Max Solids	Casing Volutes	Connections	Impeller Type	Q (GPM) @ BEP	N _s	N _{ss}	
1 ¼ x 1 x 7	BA	1521 1921 (143TC-256TC)	3500	0.187	Single	NPT	Semi-open	40	696	3310	
1 ½ x 1 ¼ x 7	BB			0.218				80	1065	2783	
2 ½ x 2 x 7	BC			0.313				120	1228	5733	
3 x 2 ½ x 7	BD			0.437				176	1433	6943	
4 x 3 x 7	BE		1750	0.812	Quad	Flanged		230	2070	7937	
4 x 4 x 7	BF			1.125	Dual			460	2091	5821	
1 ½ x 1 ¼ x 10	CA	1521 1921 (143TC-256TC)	1750	0.218	Single	NPT	Semi-open	60	507	3150	
2 x 1 ½ x 10	CB			0.250				135	733	4275	
2 ½ x 2 x 10	CC			0.218				176	868	4129	
3 x 2 ½ x 10	CD			0.437				260	1017	5018	
4 x 3 x 10	CE			1.500	0.562	Quad		Flanged	440	1311	5693
4 x 4 x 10	CF				0.500	640			1687	5808	
6 x 6 x 10	CG	1532 1932 (284TC – 326TC)		1.000	Dual		1375	2625	5479		
2 x 1 x 11	DA	1521 1921 (143TC-256TC)	1750	0.437	Single	Flanged	Enclosed	85	475	2671	
4 x 2 x 11	DB			0.500				210	757	7584	
4 x 3 x 11	DC			0.531	390			1061	9015		
6 x 4 x 11	DD			0.813	780			1546	7581		
8 x 6 x 11	DE			1.625	1750			2505	10693		
2 ½ x 1 ½ x 13	EA	1521 1921 (143TC-256TC)	1750	0.131	Single	Flanged	Enclosed	75	335	1798	
2 ½ x 2 x 13	EB			0.313				170	519	4797	
3 x 2 ½ x 13	EC			0.387				320	749	7274	
4 x 3 x 13	ED			0.531				530	926	9362	
6 x 4 x 13	EE			1532 1932 (284TC – 326TC)				0.750	700	1044	9734

***NOTE:** Bearing Frame Size vs Motor Rabbet Size: Bearing frames will only mate with certain "C"-Face motor frame rabbet sizes.

- Bearing Frame 1521 and 1921 fit Motor Rabbets 4 ½ inches and 8 ½ inches only – Motor Frame 143T-256T
- Bearing Frame 1532 and 1932 fit Motor Rabbets 10 ½ inches and 12 ½ inches only – Motor Frame 284T – 326T
- Consult Factory for Motor Frames Other Than Those Listed

1.2 G2V Ordering Code.

The following Ordering Code defines the new G2V Series pump and pump/motor and top plate arrangements. When quoting or ordering a G2V pump, **this Ordering Code must be used.**

This Ordering Code enables Carver Pump Company to accept orders quickly, assuring timely and correct manufacture of the desired pump.

G2 C - BE A - B A Z - Z Z Z

Pump Series:

G2 – General Service Vertical

Mounting Style:

C – Cantilever Design

S – Sump Design

Casing Nozzle and Impeller Sizes:

- BA** – 1 ¼ x 1 x 7 **DA** – 2 x 1 x 11
- BB** – 1 ½ x 1 ¼ x 7 **DB** – 4 x 2 x 11
- BC** – 2 ½ x 2 x 7 **DC** – 4 x 3 x 11
- BD** – 3 x 2 ½ x 7 **DD** – 6 x 4 x 11
- BE** – 4 x 3 x 7 **DE** – 8 x 6 x 11
- BF** – 4 x 4 x 7
- CA** – 1 ½ x 1 ¼ x 10 **EA** – 2 ½ x 1 ½ x 13
- CB** – 2 x 1 ½ x 10 **EB** – 2 ½ x 2 x 13
- CC** – 2 ½ x 2 x 10 **EC** – 3 x 2 ½ x 13
- CD** – 3 x 2 ½ x 10 **ED** – 4 x 3 x 13
- CE** – 4 x 3 x 10 **EE** – 6 x 4 x 13
- CF** – 4 x 4 x 10
- CG** – 6 x 6 x 10

Basic Material of Construction:

- A** – All Cast Iron Construction
- B** – 316 Stainless Steel Fitted Cast Iron Construction
- C** – All 316 Stainless Steel Construction for Major Components
- X** – Special

Column Depth (1.0 and 2.0 ft for G2C Only):

- A** – 1.0 ft (G2C) (STD) **L** – 11.0 ft (G2S only)
- B** – 2.0 ft (G2C) (EXT) **M** – 12.0 ft (G2S only)
- C** – 4.0 ft (G2S only) **N** – 13.0 ft (G2S only)
- D** – 5.0 ft (G2S only) **P** – 14.0 ft (G2S only)
- E** – 6.0 ft (G2S only) **Q** – 15.0 ft (G2S only)
- F** – 7.0 ft (G2S only) **R** – 16.0 ft (G2S only)
- G** – 8.0 ft (G2S only) **S** – 17.0 ft (G2S only)
- J** – 9.0 ft (G2S only) **T** – 18.0 ft (G2S only)
- K** – 10.0 ft (G2S only) **U** – 19.0 ft (G2S only)
- V** – 20.0 ft (G2S only)

Throttle Bushing, Lineshaft Bearing and Flush Lines:

- A** – Teflon Throttle Bushing (standard for G2C)
- B** – 17-4 PH Throttle Bushing, 416 SS Shaft Sleeve (G2C only)

For G2S Pumps: Teflon Throttle Bushing

- C** – Carbon Lineshaft Bearing, Greased for Life (standard for G2S)
- D** – Carbon Lineshaft Bearing, Externally Flushed (G2S only)
- E** – Carbon Lineshaft Bearing, Product Flushed (G2S only)

For G2S Pumps: Hardened Throttle Bushing/Sleeve

- F** – Carbon Lineshaft Bearing, Greased for Life (G2S Only)
- G** – Carbon Lineshaft Bearing, Externally Flushed (G2S only)
- H** – Carbon Lineshaft Bearing, Product Flushed (G2S only)
- X** – Special

Inlet Pipe and Strainer:

- A** – Zinc Plated Steel Strainer with Steel Tailpipe
- B** – 304 SS Strainer with 316 SS Tailpipe
- C** – Steel Tailpipe
- D** – 316 SS Tailpipe
- X** – Special Strainer and/or Tailpipe
- Z** – No Strainer or Tailpipe (Standard for G2C and G2S)

Coupling Motor Mounting Bracket and Motor:

- A** – Standard Coupling, ODP Motor, Standard Efficiency
- B** – Standard Coupling, ODP Motor, Hostile Duty
- C** – Standard Coupling, TEFC Motor, Standard Efficiency
- D** – Standard Coupling, TEFC Motor, Hostile Duty
- E** – Standard Coupling, X-P Motor, Standard Efficiency
- X** – Special Coupling, Motor Enclosure or Motor Speed
- Y** – No Motor, Pump with Coupling Only
- Z** – No Coupling or Motor – Bare Pump Only

Motor Rating (When Required):

- A** – 1.5 HP @ 1750 RPM **K** – 15 HP @ 1750 RPM
- B** – 2.0 HP @ 1750 RPM **M** – 15 HP @ 3500 RPM
- C** – 3.0 HP @ 1750 RPM **N** – 20 HP @ 1750 RPM
- D** – 5.0 HP @ 1750 RPM **P** – 20 HP @ 3500 RPM
- E** – 5.0 HP @ 3500 RPM **Q** – 25 HP @ 1750 RPM
- F** – 7.5 HP @ 1750 RPM **R** – 30 HP @ 1750 RPM
- G** – 7.5 HP @ 3500 RPM **S** – 40 HP @ 1750 RPM
- H** – 10 HP @ 1750 RPM **T** – 50 HP @ 1750 RPM
- J** – 10 HP @ 3500 RPM **U** – 60 HP @ 1750 RPM

X – Special

Z – No Motor – Bare Pump

Base Plate and Discharge Pipe Arrangement:

- A** – Steel, square, no underliner – no discharge pipe (G2C only)
- B** – Steel, square, 316 SS underliner – no discharge pipe (G2C only)
- C** – 316 SS, square – no discharge pipe
- D** – Steel, no underliner standard steel discharge pipe (standard for G2S)
- E** – Steel, no underliner, oversized steel discharge pipe (G2C only)
- G** – Steel, 316 SS underliner, Standard size steel discharge pipe
- H** – Steel, 316 SS underliner, oversized steel discharge pipe (G2C only)
- K** – Steel, no underliner, standard size 316 SS discharge pipe
- L** – Steel, no underliner, oversized 316 SS discharge pipe (G2C only)
- N** – Steel, 316 SS underliner, standard size 316 SS discharge pipe
- P** – Steel, 316 SS underliner, oversized 316 SS discharge pipe (G2C only)
- R** – 316 SS, standard size steel discharge pipe
- S** – 316 SS, oversized steel discharge pipe (G2C only)
- U** – 316 SS, standard size 316 SS discharge pipe
- X** – Special
- Z** – No top plate or discharge pipe – bare pump only (standard for G2C)

1.3 Standard Surface Treatment.

All G2V Series components handling fluids are painted to Carver Standard PA-001. This provides one coat of Carver Blue industrial alkyd metal enamel with a 3-5 mils dry film thickness. All paint is applied over a clean, dry, bare metal surface.

All iron castings are spot primed over any area exhibiting minor discoloration from rust or oxidation.

1.4 Material of Construction.

The standard G2V materials and material specifications are given in the table below:

Key Component Materials		
Component	Material	Specification
Bearing Frame	Cast iron	ASTM A48, Class 30
Casing	Cast iron	ASTM A48, Class 30
	316 SS	ASTM A744, Grade CF-8M
Impeller	Cast iron	ASTM A48, Class 30
	316 SS	ASTM A744, Grade CF-8M
Motor Bracket	Cast iron	ASTM A48, Class 30
Lineshaft Bearing	Tin bronze	ASTM B30, C90300
	Carbon	Antimony filled
O Ring	Elastomer	Viton
Piping	Steel	ASTM A106
	316 SS	ASTM A312
Shaft	Steel – G2C	ASTM A108, Grade 1215
	Steel – G2S	ASTM A434, Grade 4140
	316 SS	ASTM A276, UNS S31600
Shaft sleeve (optional)	416 SS	ASTM A582, Type 416
Slinger	Alloy 20	ASTM A744, Grade CN-7M
	Elastomer	Viton
Throttle bushing	Steel	ASTM A106
	316 SS	ASTM A312
	Teflon	15% glass, 5% molybdenum
	17-4 PH SS	ASTM A564, Type 630
Underliner	316 SS	ASTM A240, Type 316

Bearing Frame/Motor Selection		
Bearing Frame	Motor Rabbet	Motor Frames
1521 and 1921	4-1/2 and 8-1/2	143TC – 256TC
1532 and 1932	10-1/2 and 12-1/2	284TC – 365TC

1.5 Key G2C Data.

Many of the key G2C design parameters are specified in the table below:

Key G2C Data			
Item	Bearing Frame		
	1521	1532	
Motor Frame	143TC-256TC	284TC-326TC	
Max power (BHP) @ 1750 RPM	20	75	
	@ 3500 RPM	20	N/a
Radial bearing type	207	210	
Thrust bearing type	307	5308	
Thrust bearing lube (standard)	Grease		
Shaft diameter @	coupling	1.250	1.375
	radial bearing	1.378	1.969
	thrust bearing	1.378	1.575
	impeller hub	0.875	1.250
Shaft diameter under sleeve	1.000	1.375	
Shaft sleeve O.D.	1.250	1.750	
L ₁₀ bearing life (hrs) - radial	50,000 Minimum		
L ₁₀ bearing life (hrs) - thrust	25,000 Minimum		

1.6 Key G2S Data.

Many of the key G2S design parameters are specified in the table below:

Key G2S Data			
Item	Bearing Frame		
	1921	1932	
Motor Frame	143TC-256TC	284TC-326TC	
Max power (BHP) @ 1750 - 3500 RPM	20 - 20	75 - n/a	
Radial bearing type	Journal	Journal	
Thrust bearing type	5307	5308	
Thrust bearing lubrication (standard)	Grease		
Line shaft lubrication (options)	Grease, Water or product		
Shaft diameter @	coupling	1.250	1.250
	radial bearing	1.500	1.500
	thrust bearing	1.378	1.378
	impeller hub	0.875	1.250
WR ² of Rotor (lb – in.) – 4' column	7.98	8.20	
	for each additional 2' add	3.38	3.38
WR ² of Rotor (lb – in.) – 7" impellers	15.10	15.10	
	10" impellers	56.67	56.67
	11" impellers	137.56	137.56
	13" impellers	233.74	233.74
L ₁₀ bearing life (hrs) - radial	50,000 Minimum		
L ₁₀ bearing life (hrs) - thrust	25,000 Minimum		

1.7 Seal Arrangement.

To successfully select a G2V pump the following information must be known:

a. Hydraulics

- fluid to be pumped
- flow rate
- tank fluid level (min, normal and max)
- discharge pressure
- viscosity (min, normal and max)
- temperature (min, normal and max)
- specific gravity (min, normal and max)
- NPSH available
- vapor pressure

b. Materials

- casing, piping and top plate
- shafts
- impellers
- throttle bushings
- wear rings

c. Configurations / Accessories

- driver (speed, type, rating, manufacturer)
- coupling (torque, type, manufacturer)
- top plates (type, options)

1.8 Vertical Pump Discharge Head.

While the flow required of a pump is generally well known, the total head against which it must pump is often more difficult to determine. With vertical pumps one frequently overlooked item is that the pump discharge originates at the pump casing below the tank or pit surface, not at the discharge flange at the tank top. Therefore, to correctly determine the discharge head required, the elevation between the actual pump discharge point and the distance to the tank or pit surface, and the resulting fluid friction losses encountered along this length of pipe, must also be considered.

1.9 NPSH & Submergence.

The *minimum* net positive suction head (NPSH) required is the net amount of hydraulic energy above vapor pressure needed to overcome elevation and friction losses and deliver fluid into the eye of the impeller. NPSH is generally understood with horizontal pumps, but with vertical pumps one other related consideration is the concept of **submergence**. Submergence is the height of a fluid above the pump's inlet, or conversely, the depth of the vertical pump's inlet below the fluid surface. Submergence is not the same

as NPSH, and it must always be large enough to maintain sufficient NPSH available and prevent **vortexing**.

When a surface vortex develops in a vertical pump installation, air is pulled down from the fluid surface into the pump inlet.

This in turn can be a serious problem, and some of its consequences are:

- rotor assembly imbalance and vibration
- accelerated wear due to dry running
- accelerated wear due to hydraulic shock loads as the air passes through the pump
- erratic performance, with loss of flow and head

This last point is often overlooked, since air entrainment as little as a one percent by volume will produce a noticeable drop-off in pump performance, and a two percent by volume air entrainment on the inlet can reduce the pump flow rate by as much as 10%.

The two most common conditions for vortex formation are insufficient submergence depth and excessive suction piping fluid velocity. System design guidelines for overcoming this are published by the Hydraulic Institute and others.

In addition to the various (and often contradictory) published recommendations on this, a simple rule of thumb often used is to set the submergence depth to 6 times the nominal inlet size diameter of the pump (i.e., set $H > 6D$). For smaller pumps less than 100 GPM this is often simplified to $H > 18"$, and for larger pumps over 1,200 GPM this is simplified to $H > 8D$ – see sketch below.

The pump inlet, whether it is the pump casing or an extended inlet pipe, should be sized to a distance of 0.3 to 0.8 D to the tank bottom, with 0.5 D considered optimal, where D is the nominal inlet diameter.

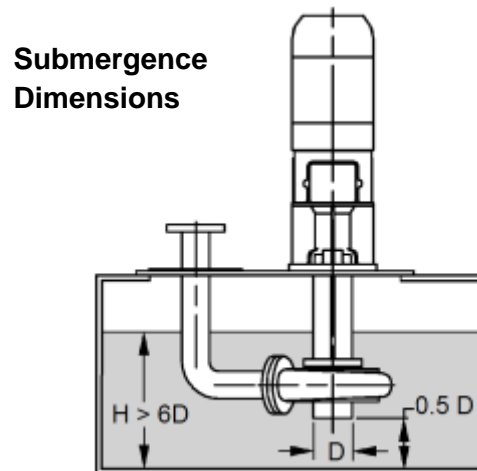

This is important because if this inlet to tank bottom distance is too great, the submergence depth is lessened. On the other hand, if the distance is too small, debris and other foreign matter on the tank bottom can be drawn in to the pump, in effect making the pump a vacuum cleaner for the tank.

Lastly, vortex breakers in the form of inlet baffles, weirs and/or suction strainers can be very effective in preventing vortices from forming in the system. Therefore, it is recommended that every G2V series pump be equipped with a suction strainer. When pumping fluids over 1,000 SSU, the finest strainer screen practical is about 1/8" perforation. It is also advisable to monitor the strainer with a differential pressure gauge or switch, since a clogged strainer will cause a pump to cavitate.

1.10 A Typical G2V Series Specification (Specifier's options in parentheses)

Each pump shall be a vertical, end suction, centrifugal pump capable of developing (500) US GPM at a total head of (200) feet when pumping (water) at a temperature of (100) °F with a fluid specific gravity of (1.00) without the use of special clearances, materials, or other internal or external modifications. In meeting these hydraulic conditions the pump shall have an NPSH requirement of not more than (10) feet and a hydraulic operating efficiency at the normal duty point of at least (70.0)% as defined by the Hydraulic Institute Level A requirements, which includes all seal, lineshaft bearing and/or throttle bushing losses.

The pump shall include separate liquid end, support column and bearing frame sections for ease of maintenance. The liquid end shall be cast iron (316 stainless steel), with all components below the top plate surface fully compatible with the temperature, corrosion and abrasion properties of the fluid being pumped.

The impellers shall be precision cast iron (316 stainless steel) and positively keyed to the pump drive shaft for more positive driving and to prevent the impeller from spinning off the shaft and damaging itself and/or the pump casing in the event of accidental reverse rotation. As a further means of assuring longer component life, all impellers shall be dynamically balanced in accordance with ISO 1940/1 guidelines.

The bearing frame shall be located above the top mounting surface for ease of access. It shall consist of two grease-lubricated ball bearings to handle all radial and axial loads. The thrust bearing shall have a minimum L10 life of 25,000 hours and the radial bearing shall have a minimum L10 life of 50,000 hours.

For added reliability, the bearings shall be protected from any fluid vapors by means of a spring-loaded lip



G2S Pump

seal. The bearings and shaft shall be designed to provide minimum deflection throughout the entire range of pump operation.

For optimum efficiency and to assure long life without degradation in performance over time, the bearing frame assembly shall have the means of externally adjusting the impeller axial position without disassembling the pump or otherwise removing it from the system.

The pump shall have a replaceable Teflon throttle bushing on the impeller end. (Hardened 17-4 stainless steel throttle bushing with a hardened 416 stainless steel shaft sleeve when pumping fluids with dirt or abrasives present.) In all cases, the throttle bushing shall not be used as a bearing surface, and the maximum deflection at the throttle bushing shall not exceed 0.010 inches. All extended length sump pumps shall have as a minimum one lineshaft bearing for each 4.0 foot of column length. The lineshaft bearing shall be carbon and capable of being either permanently grease lubricated or externally lubricated and flushed by either oil, water or the fluid being pumped.

The pump shall be supplied complete with an electric motor, top plate, (discharge piping), (inlet strainer), coupling and coupling guard. It shall be capable of operating throughout the entire range of its performance curve without exceeding the nameplate horsepower rating of its motor.

The pump shall be a heavy-duty industrial design, G2V Series as manufactured by the Carver Pump Company of Muscatine, Iowa, or approved ISO-9001 certified, United States manufactured equal.

G2S Lineshaft Bearing Flush and Lubrication Options

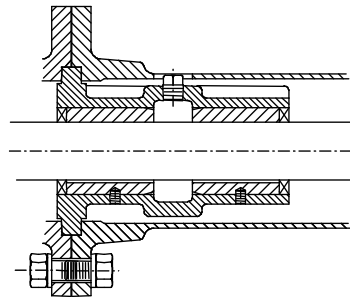

Fig. 1 Greased for Life

Carbon bearings, sealed at both ends, flush connection drilled, tapped and plugged, with no external flush

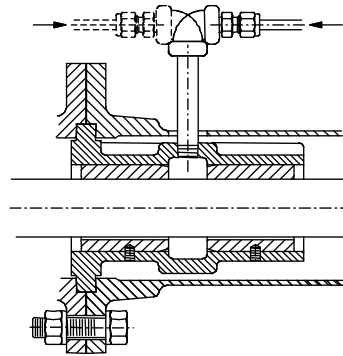

Fig. 2 External or Product Flushed

Carbon bearings open at both ends. Product flush from point on pump discharge, water flush from external source (by others)

1.11 G2V Series Bearing Frame Designations

The standard G2V bearing frames can be seen in the chart below. The **standard** G2V setting is 12 inches long, giving a 12 inch drop between the bottom of the

mounting plate and back of the pump casing while the **extended** column setting has a 24 inch drop between the bottom of the mounting plate and back of the pump casing.

1521 Bearing Frame

Up to 3500 RPM / 20 HP

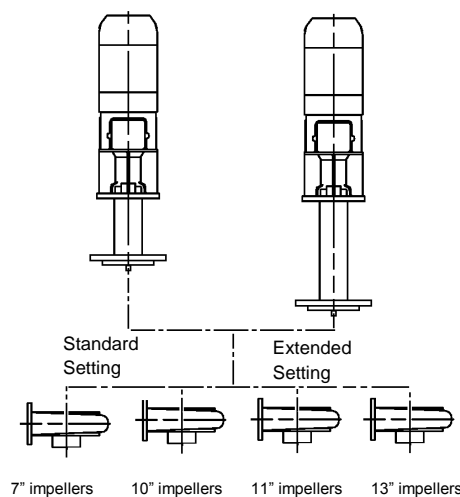

1532 Bearing Frame

Up to 1750 RPM / 75 HP

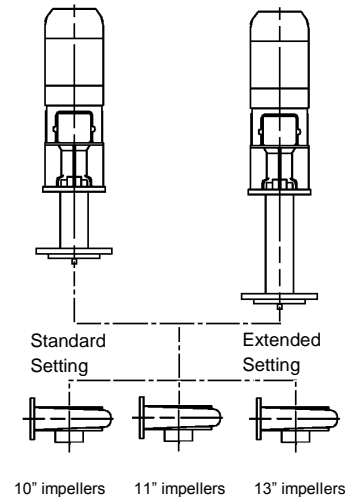

1.12 GV Series Hydraulic Coverage and Performance by Individual Size.

G2V hydraulic performance extends to flows of 2500 GPM at 1750 RPM with twenty three sizes in cast iron, 316 SS fitted cast iron, or all 316 stainless steel. Pumps with 7", 10" and 11" impeller suction connections are provided with NPT connections. Pumps with 13" suction connections are provided with flanged connections.

Replaceable 17-4 PH front and rear wear rings are standard with all stainless units with enclosed impellers (i.e., 11" diameter and above) as standard, except for the sizes 2 x 1 x 11 and 2½ x 1½ x 13, which have front wear rings only.

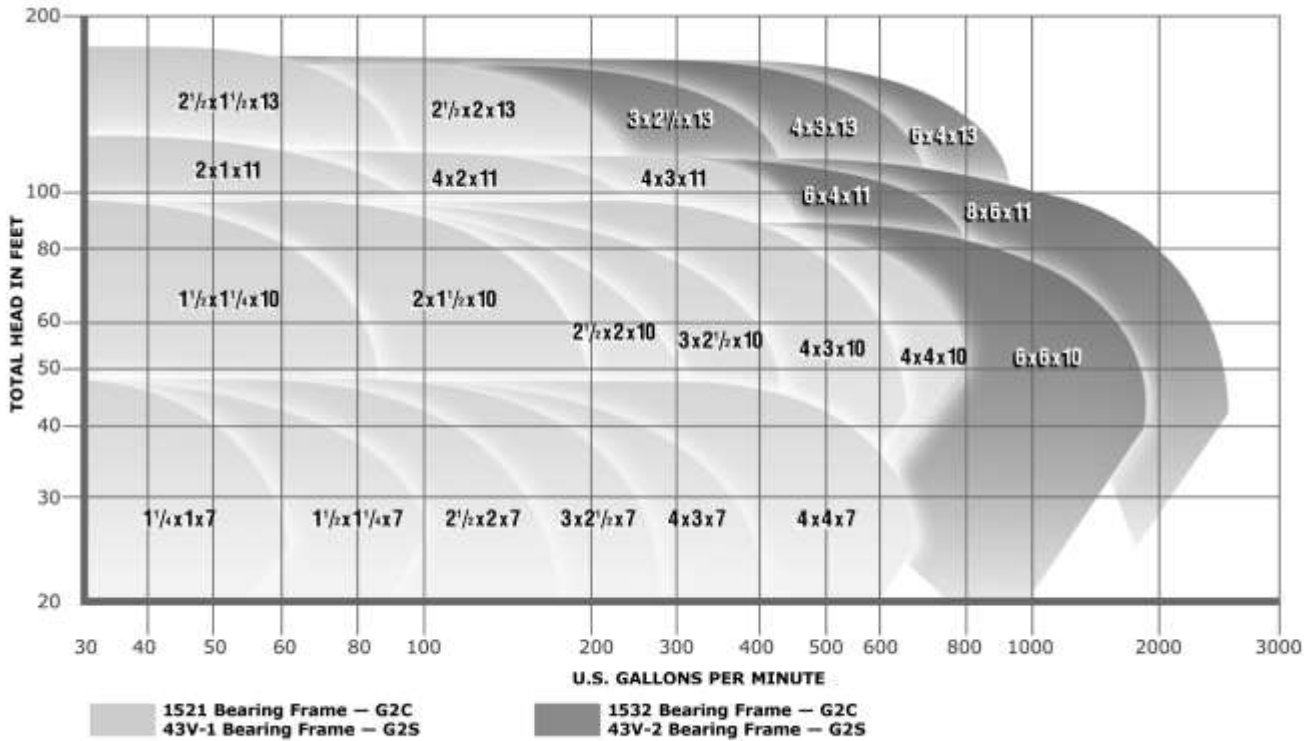

Hydraulic Performance - 7 Inch Impellers

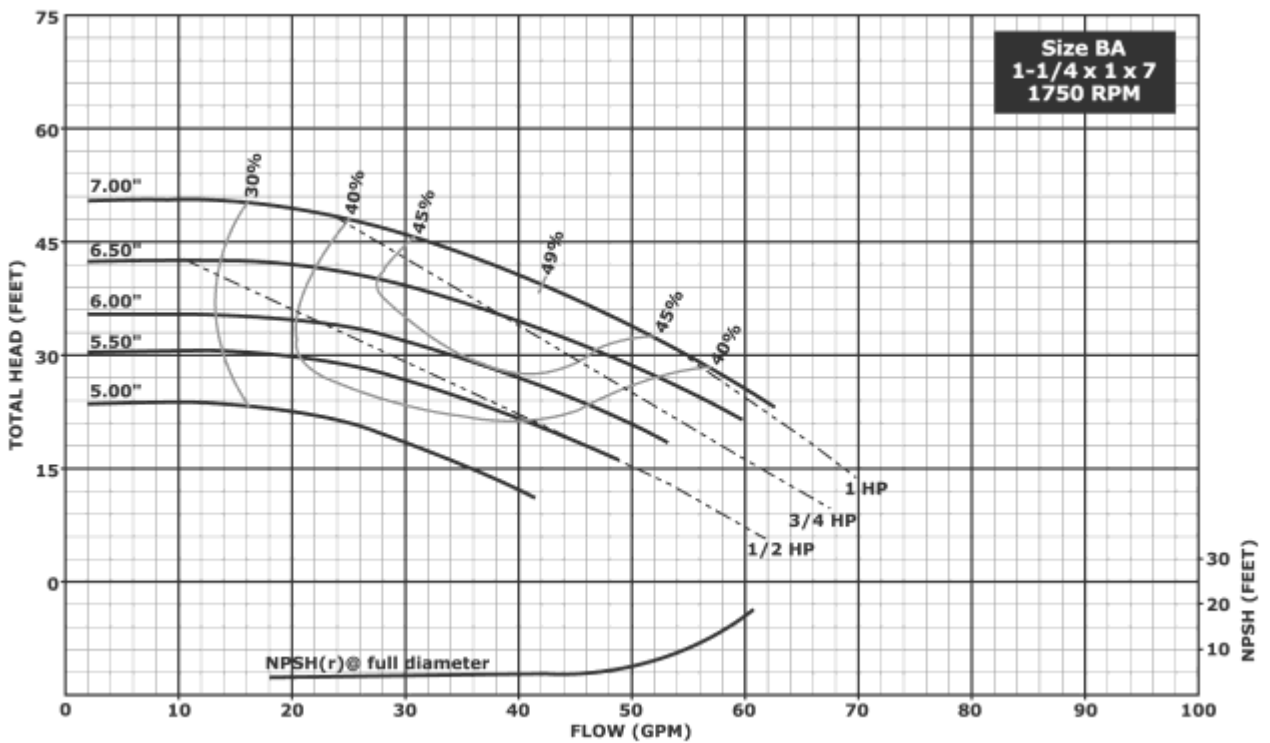
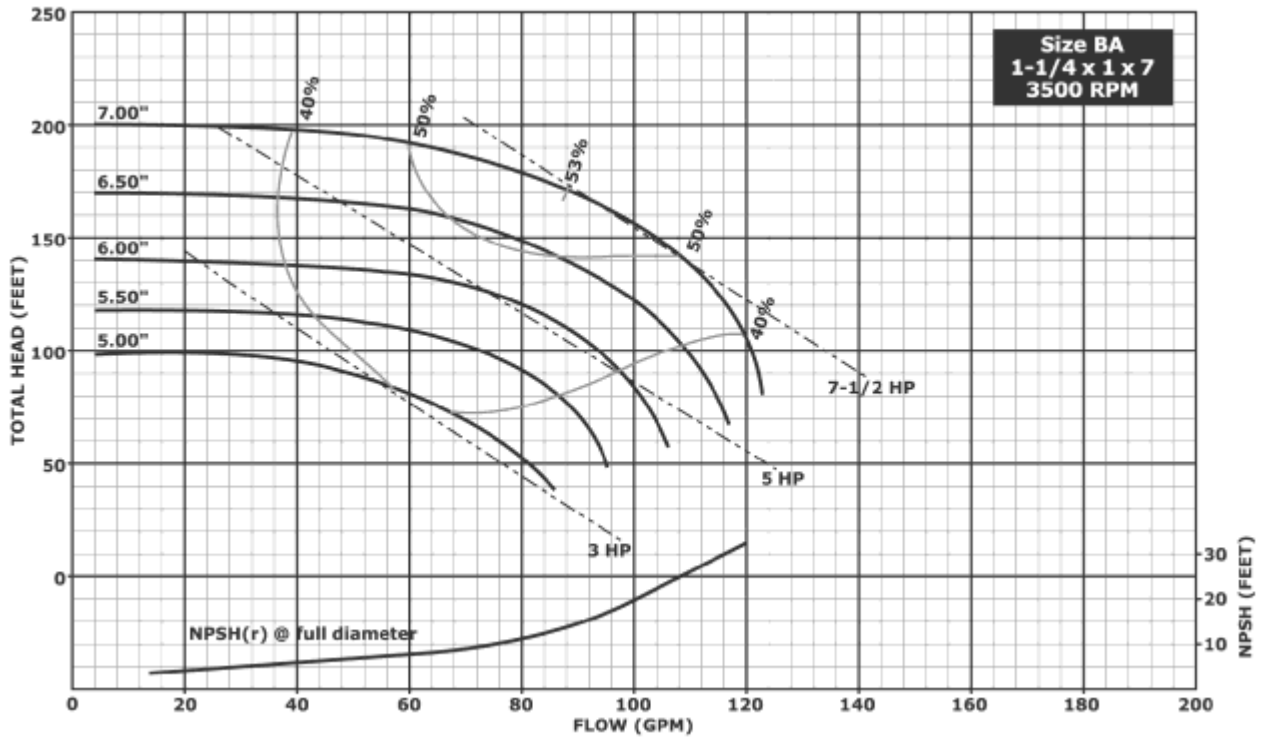

Notes:

1. Above data is based on 1.0 sp. gr. water at ambient temperature and pressure in accordance with Hydraulic Institute guidelines.
2. Impeller diameters between minimum and maximum shown are available in 1/8 inch increment trims.
3. For special G2S requirements at start up refer to Table 1.13.

Hydraulic Performance - 7 Inch Impellers

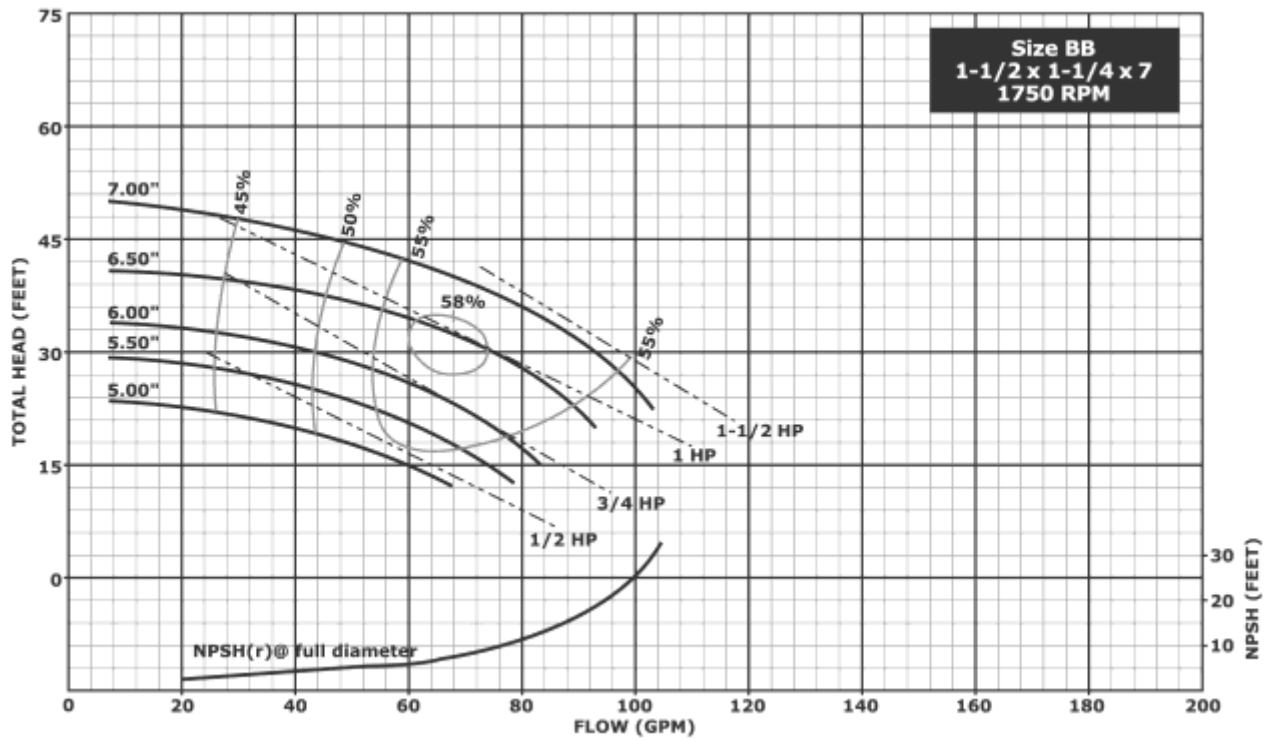
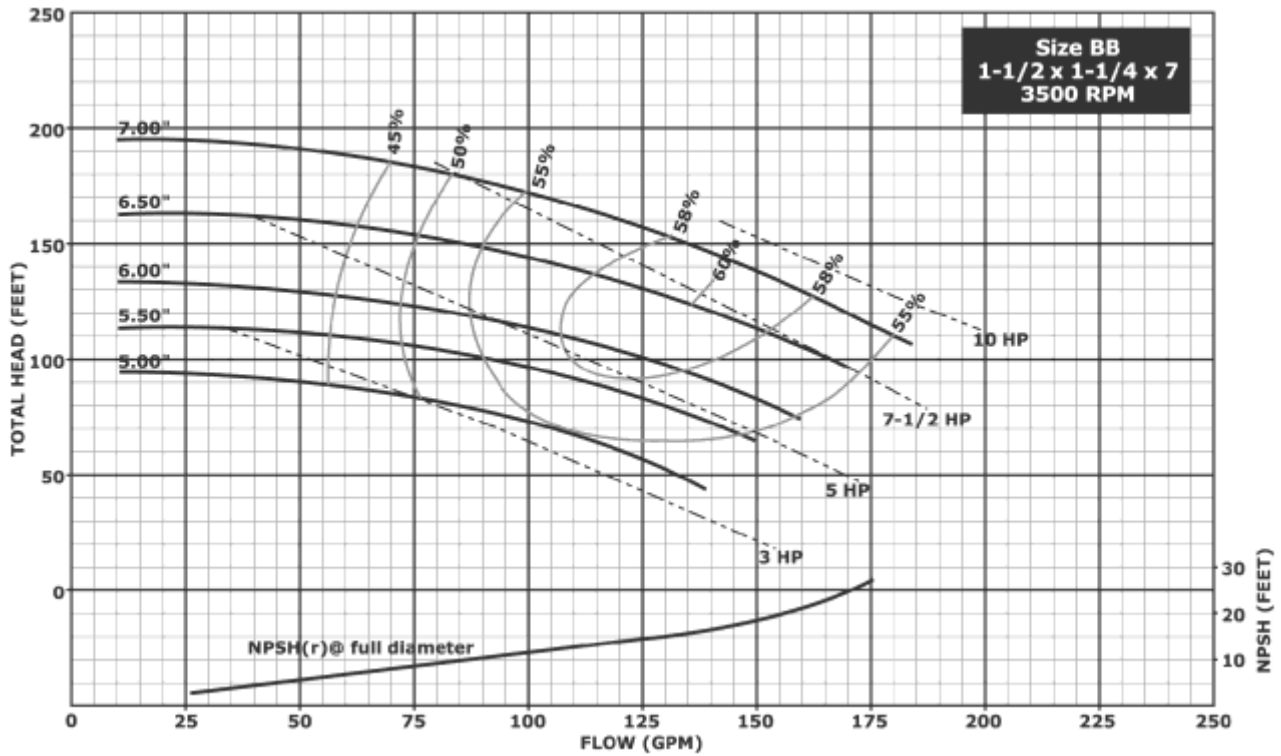

Notes:

1. Above data is based on 1.0 sp. gr. water at ambient temperature and pressure in accordance with Hydraulic Institute guidelines.
2. Impeller diameters between minimum and maximum shown are available in 1/8 inch increment trims.
3. For special G2S requirements at start up refer to Table 1.13.

Hydraulic Performance - 7 Inch Impellers

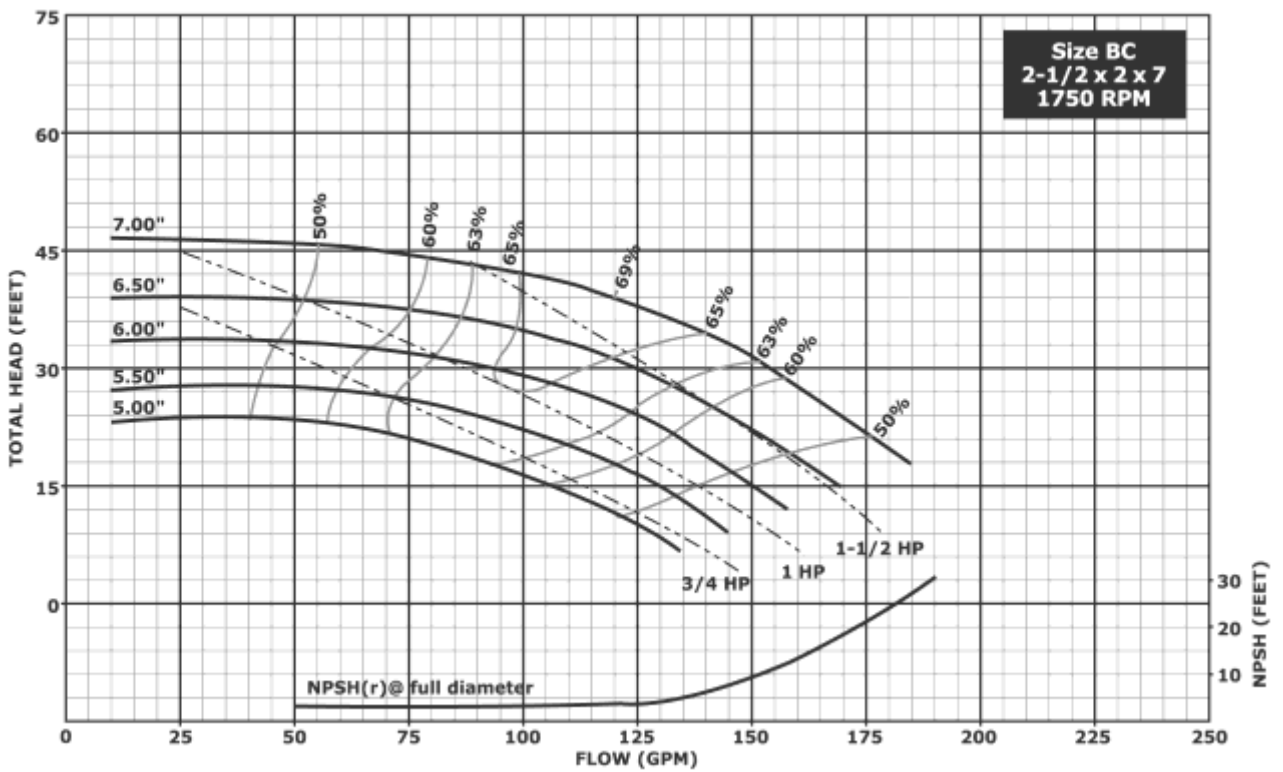
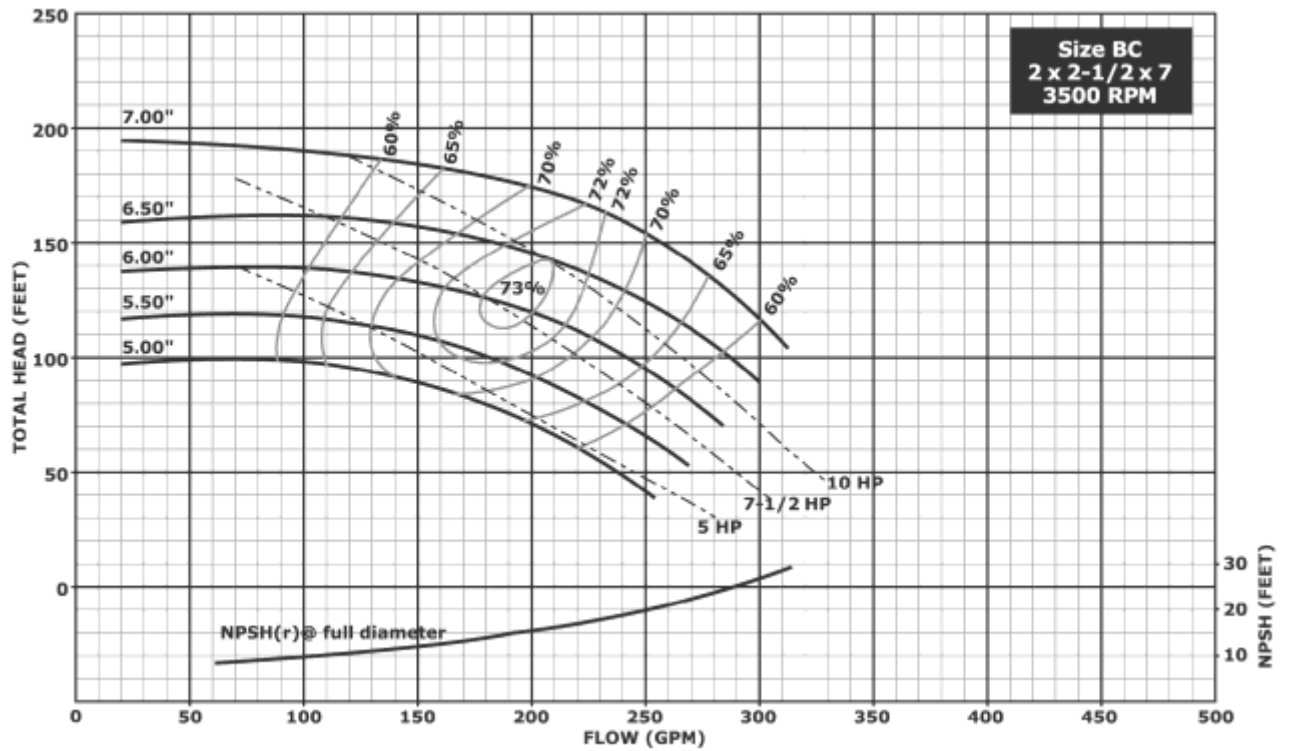

Notes:

1. Above data is based on 1.0 sp. gr. water at ambient temperature and pressure in accordance with Hydraulic Institute guidelines.
2. Impeller diameters between minimum and maximum shown are available in 1/8 inch increment trims.
3. For special G2S requirements at start up refer to Table 1.13.

Hydraulic Performance - 7 Inch Impellers

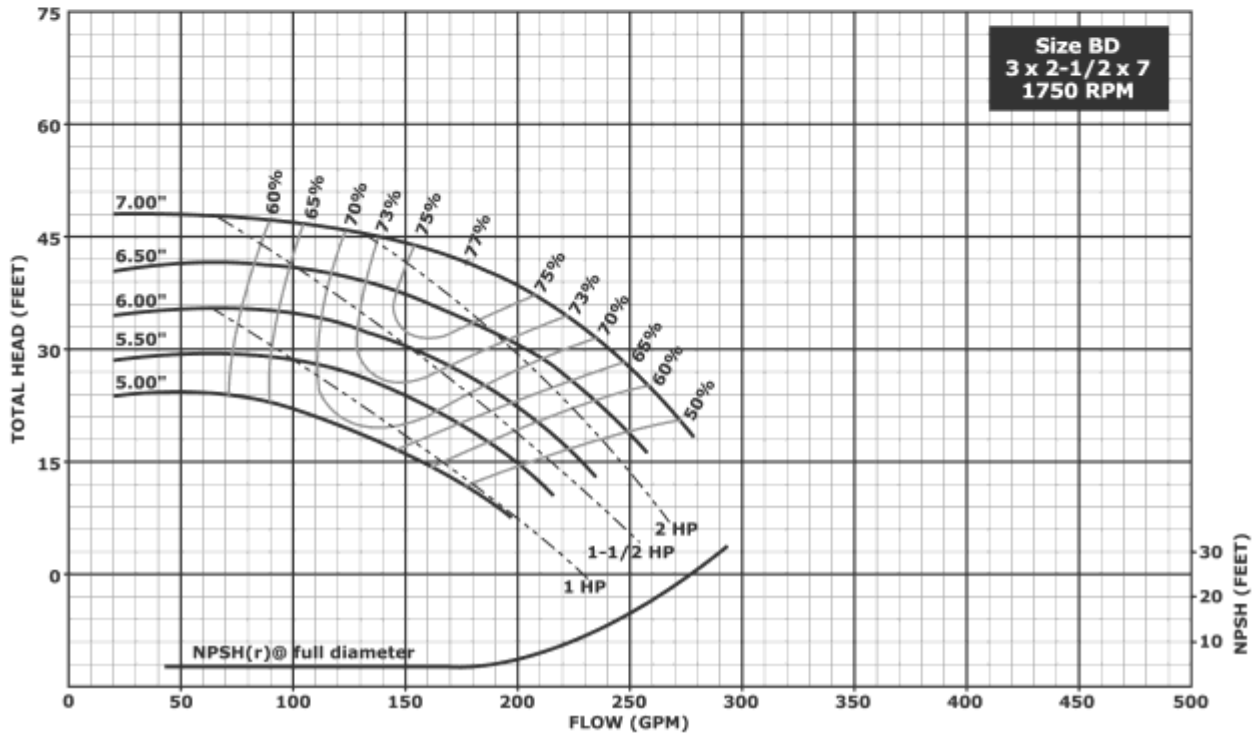
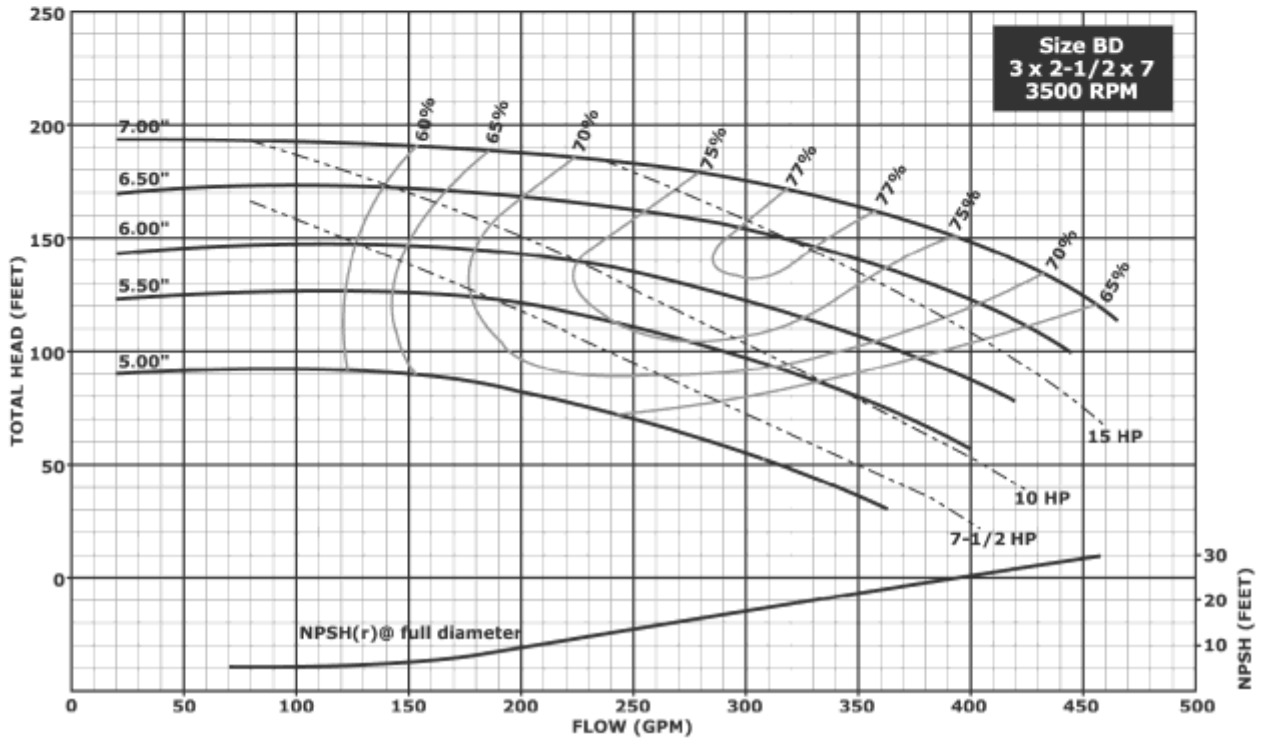

Notes:

1. Above data is based on 1.0 sp. gr. water at ambient temperature and pressure in accordance with Hydraulic Institute guidelines.
2. Impeller diameters between minimum and maximum shown are available in 1/8 inch increment trims.
3. For special G2S power requirements at start up refer to Table 1.13.

Hydraulic Performance - 7 Inch Impellers

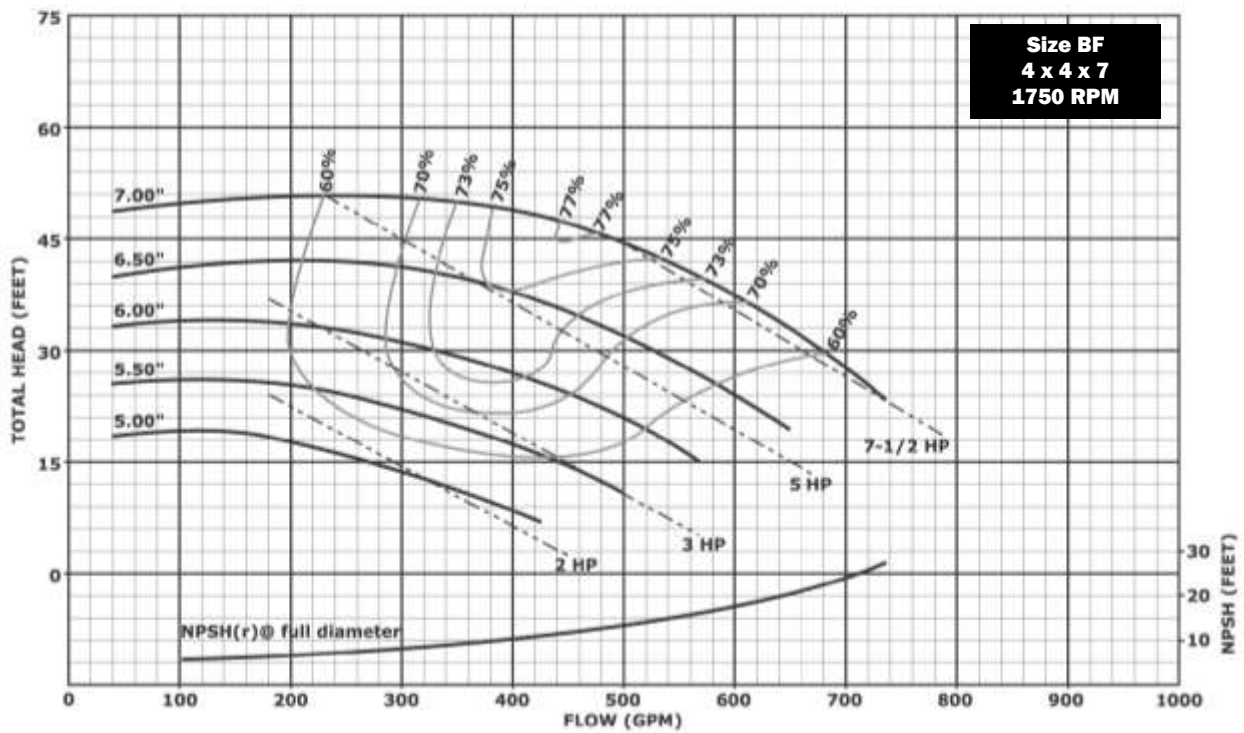
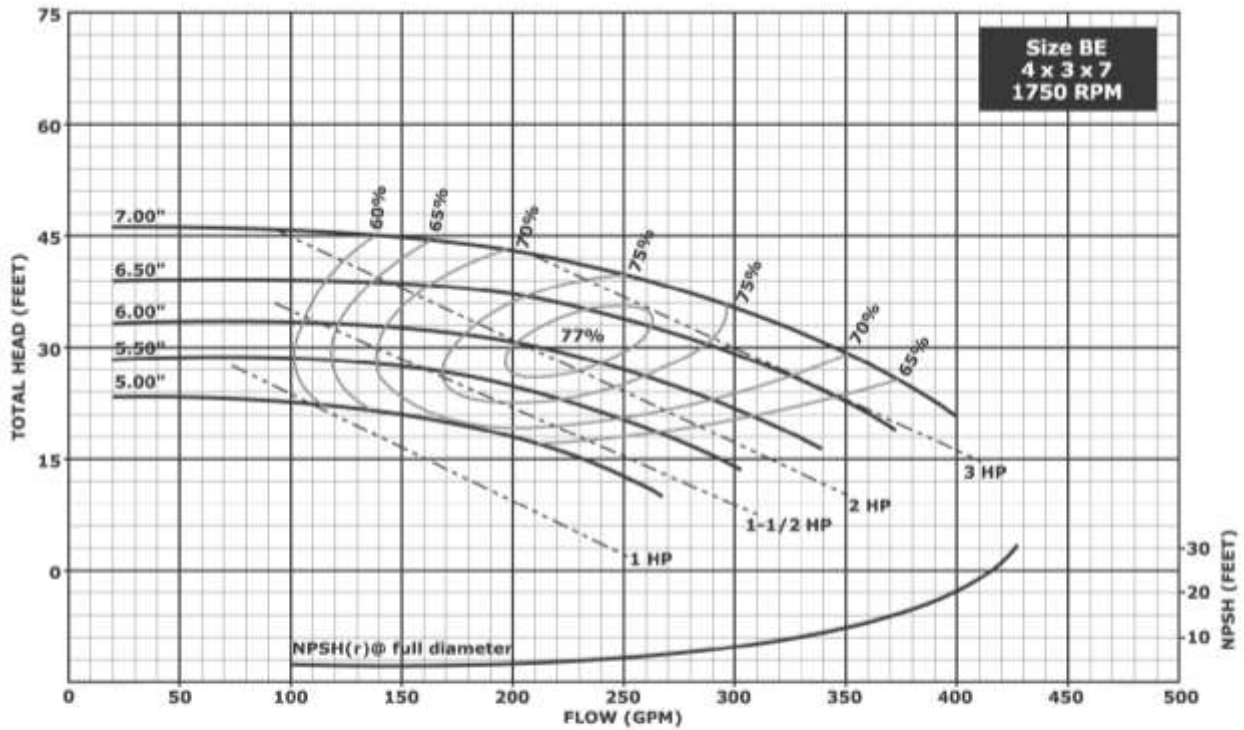

Notes:

1. Above data is based on 1.0 sp. gr. water at ambient temperature and pressure in accordance with Hydraulic Institute guidelines.
2. Impeller diameters between minimum and maximum shown are available in 1/8 inch increment trims.
3. For special G2S power requirements at start up refer to Table 1.13.

Hydraulic Performance - 10 Inch Impellers

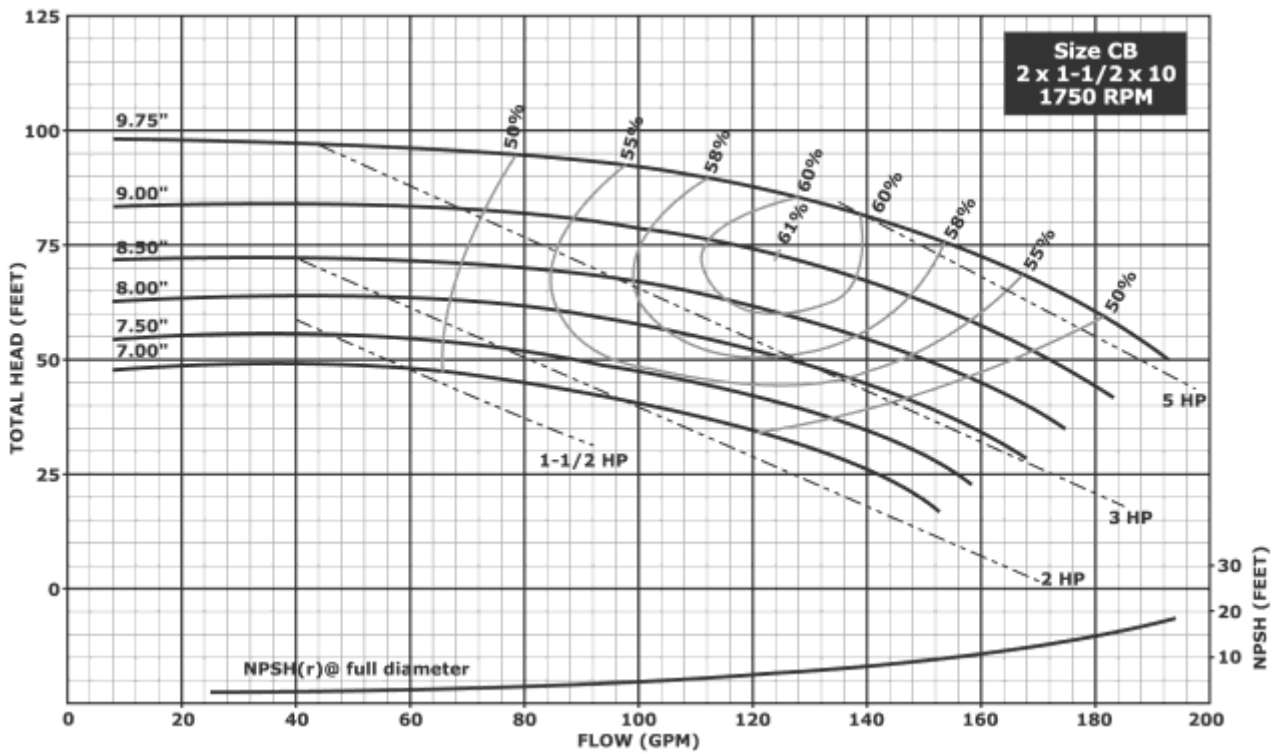
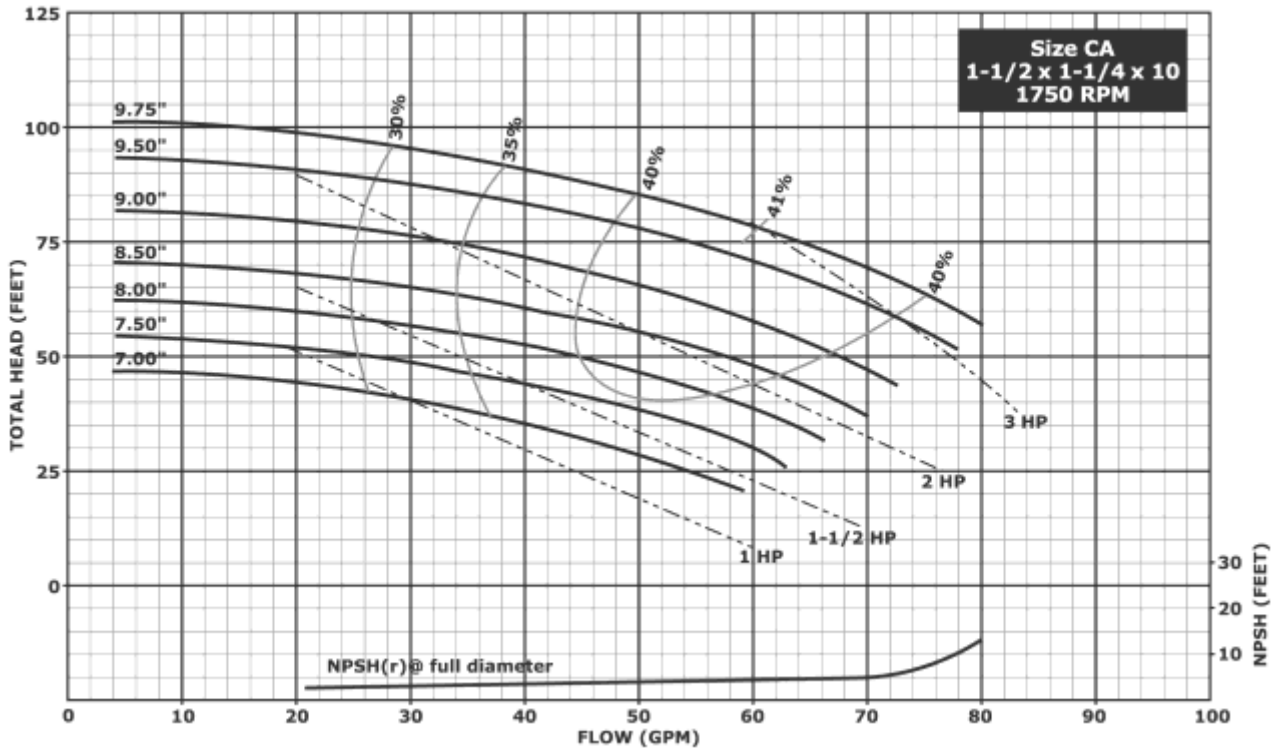

Notes:

1. Above data is based on 1.0 sp. gr. water at ambient temperature and pressure in accordance with Hydraulic Institute guidelines.
2. Impeller diameters between minimum and maximum shown are available in 1/8 inch increment trims.
3. For special G2S power requirements at start up refer to Table 1.13.

Hydraulic Performance - 10 Inch Impellers

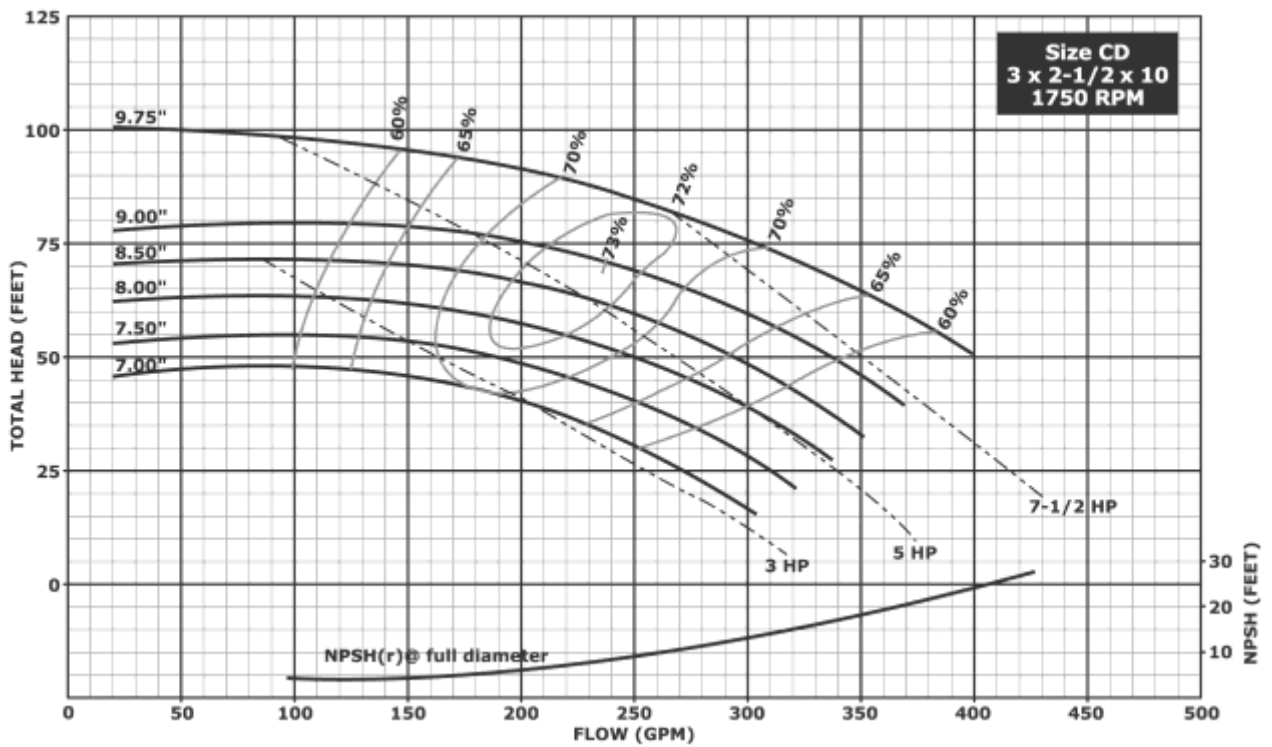
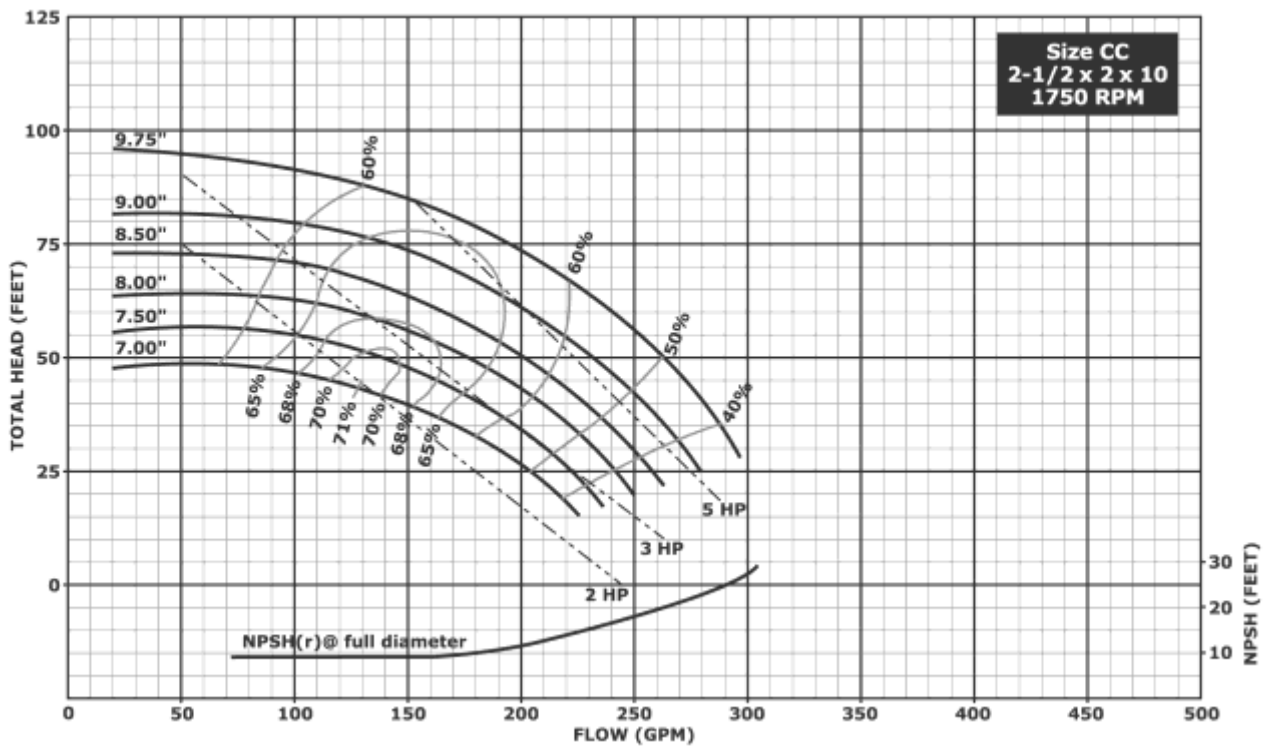

Notes:

1. Above data is based on 1.0 sp. gr. water at ambient temperature and pressure in accordance with Hydraulic Institute guidelines.
2. Impeller diameters between minimum and maximum shown are available in 1/8 inch increment trims.
3. For special G2S power requirements at start up refer to Table 1.13.

Hydraulic Performance - 10 Inch Impellers

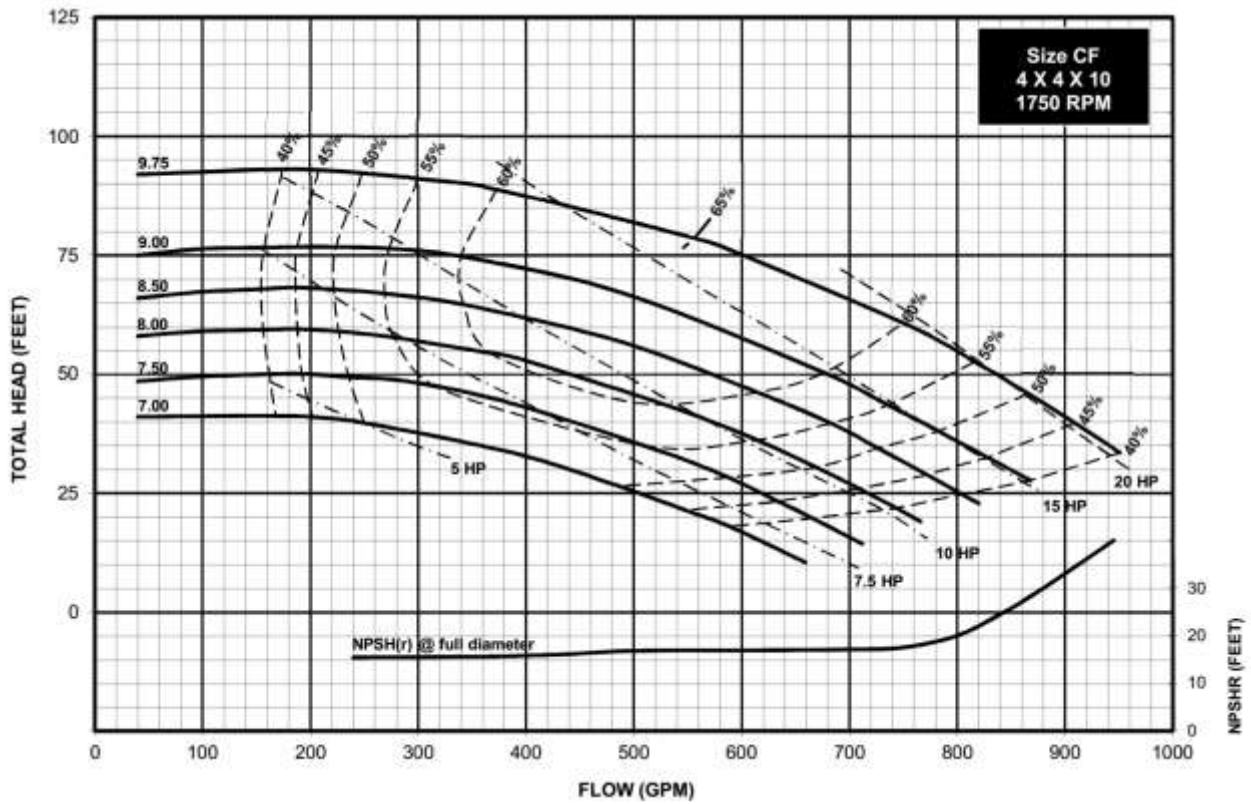
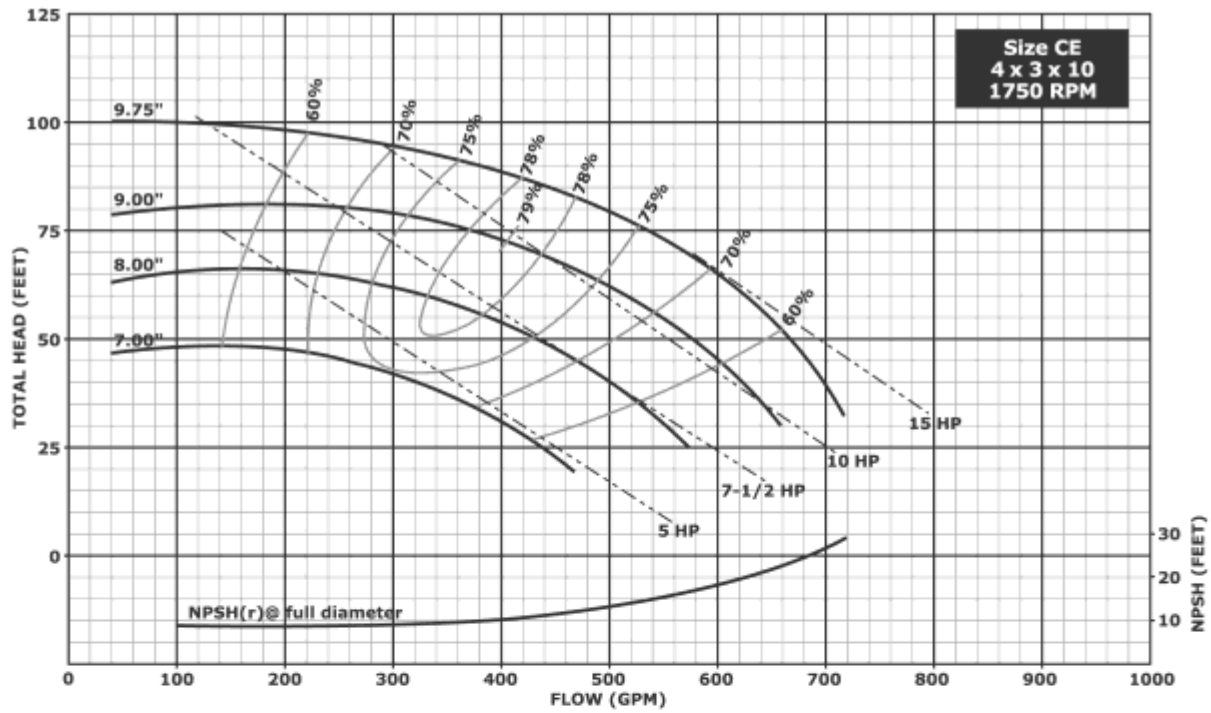

Notes:

1. Above data is based on 1.0 sp. gr. water at ambient temperature and pressure in accordance with Hydraulic Institute guidelines.
2. Impeller diameters between minimum and maximum shown are available in 1/8 inch increment trims.
3. For special G2S power requirements at start up refer to Table 1.13.

Hydraulic Performance - 10 and 11 Inch Impellers

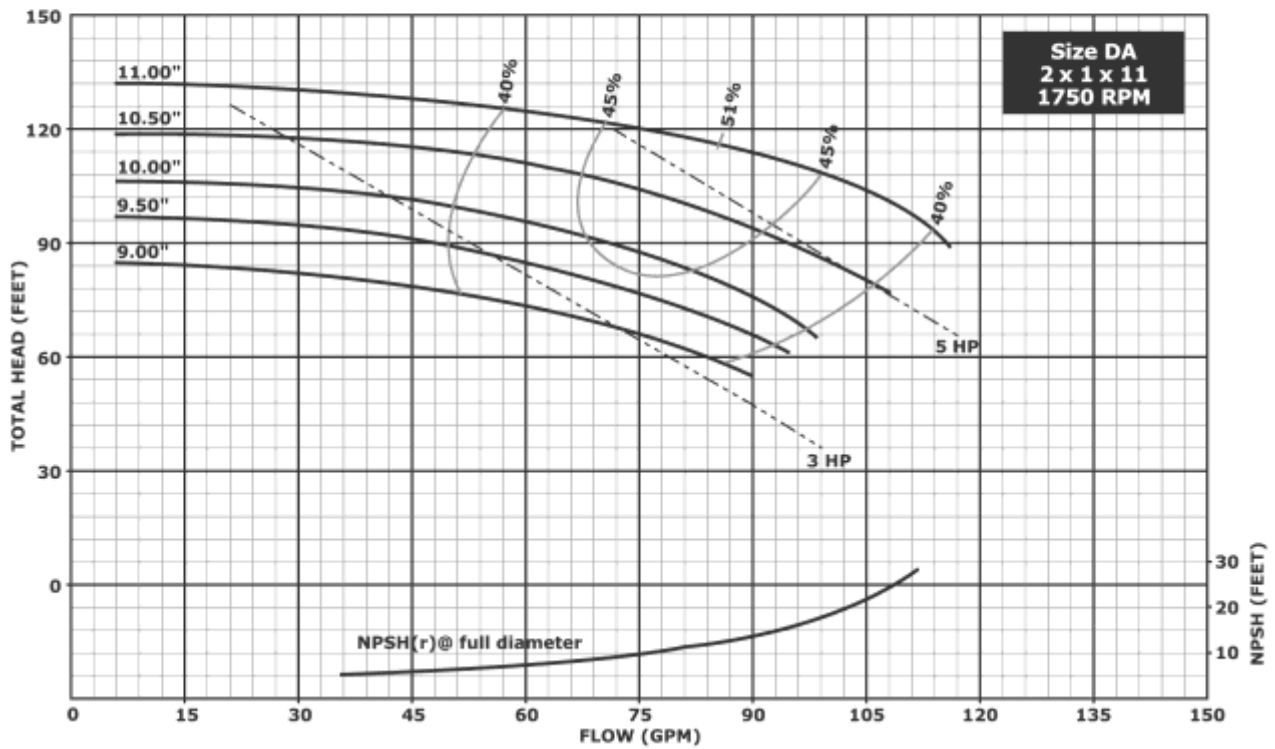
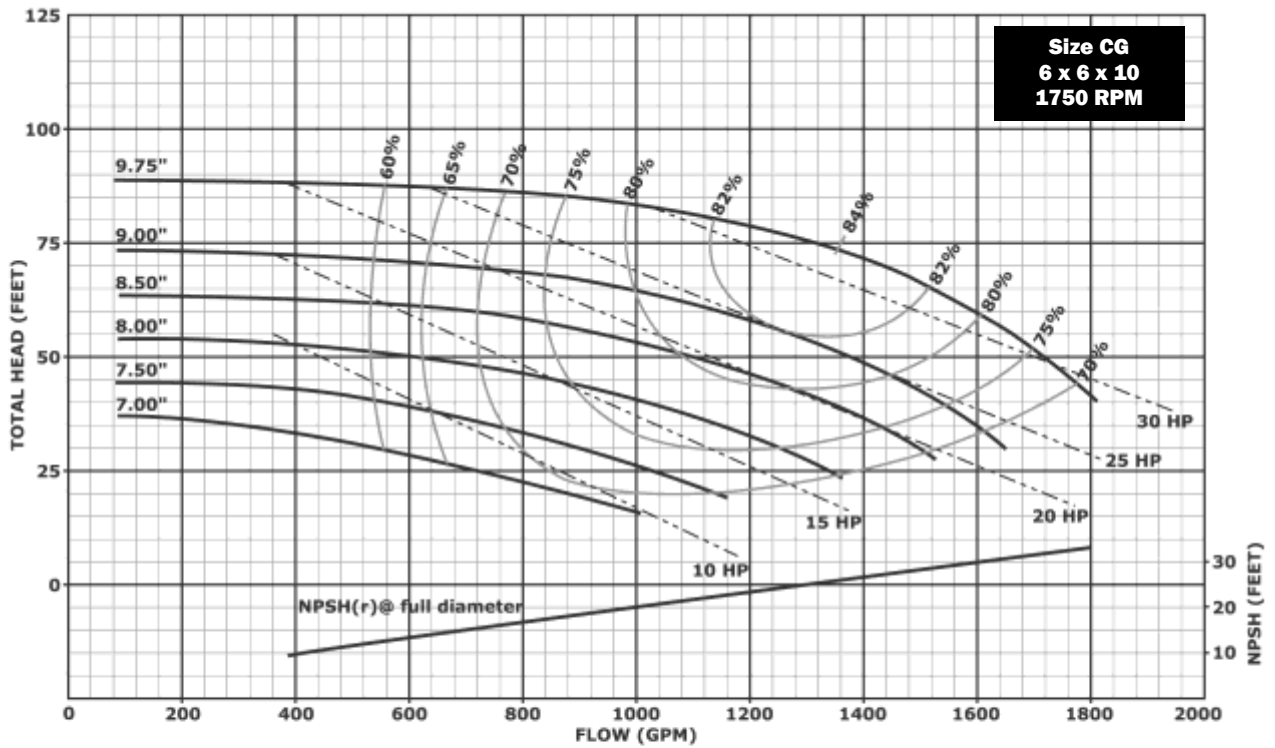

Notes:

1. Above data is based on 1.0 sp. gr. water at ambient temperature and pressure in accordance with Hydraulic Institute guidelines.
2. Impeller diameters between minimum and maximum shown are available in 1/8 inch increment trims.
3. For special G2S power requirements at start up refer to Table 1.13.

Hydraulic Performance - 11 Inch Impellers

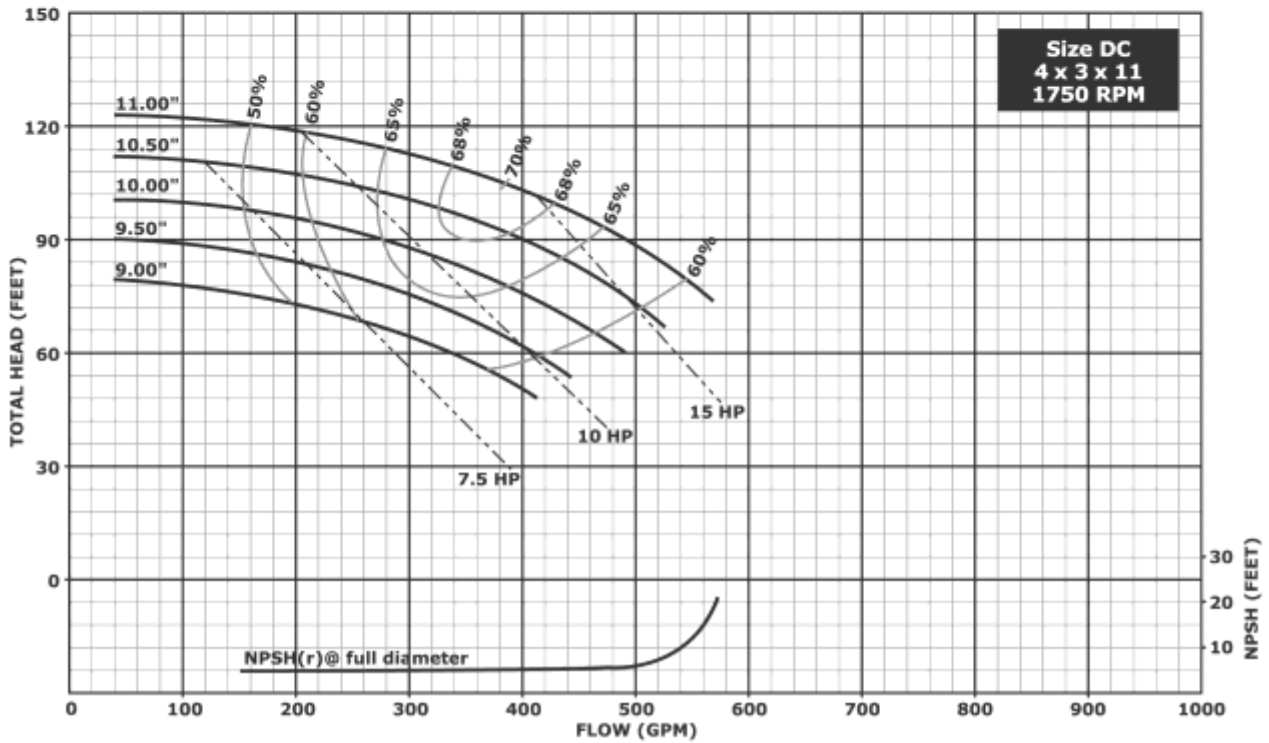
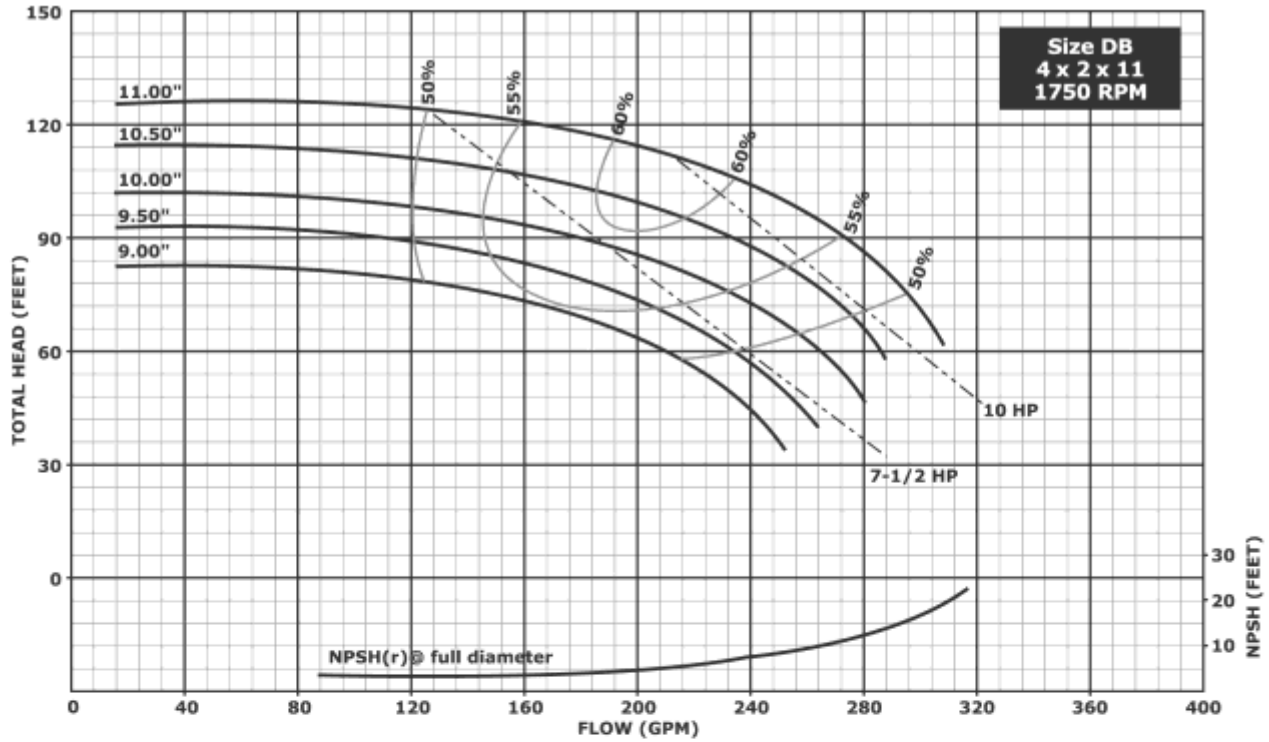

Notes:

1. Above data is based on 1.0 sp. gr. water at ambient temperature and pressure in accordance with Hydraulic Institute guidelines.
2. Impeller diameters between minimum and maximum shown are available in 1/8 inch increment trims.
3. For special G2S power requirements at start up refer to Table 1.13.

Hydraulic Performance - 11 Inch Impellers

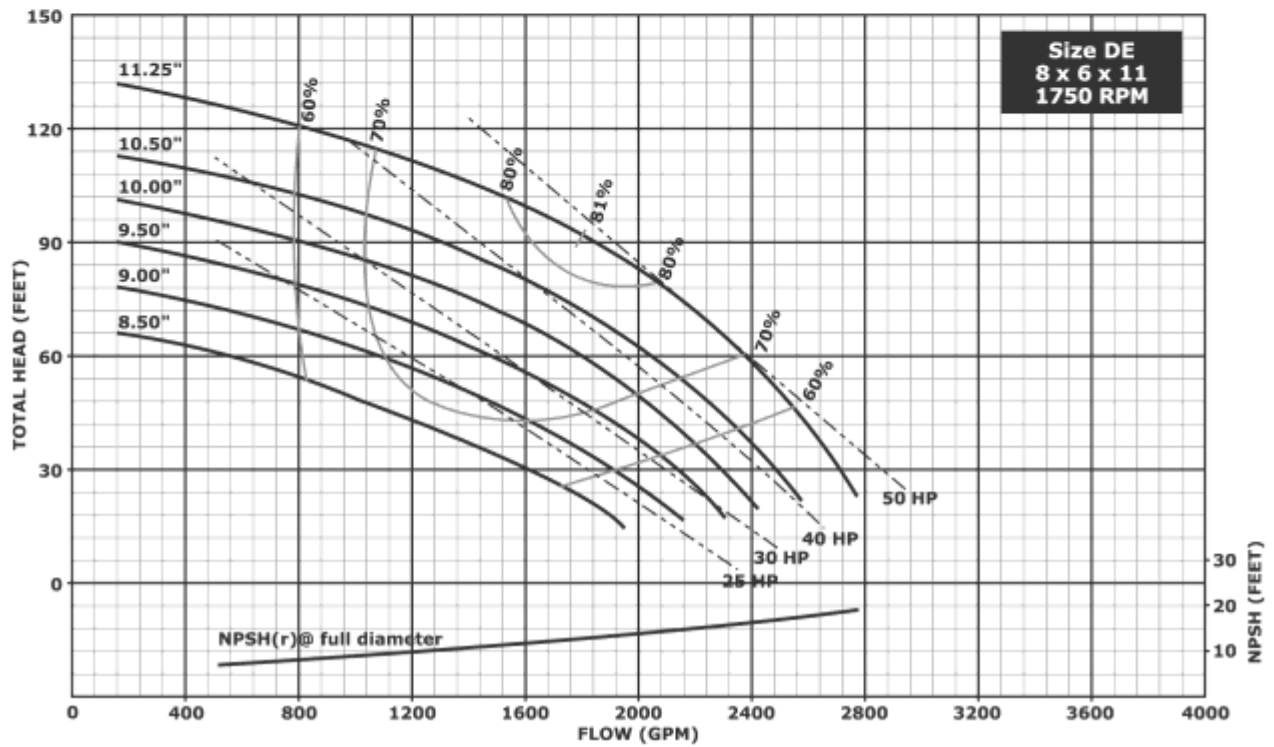
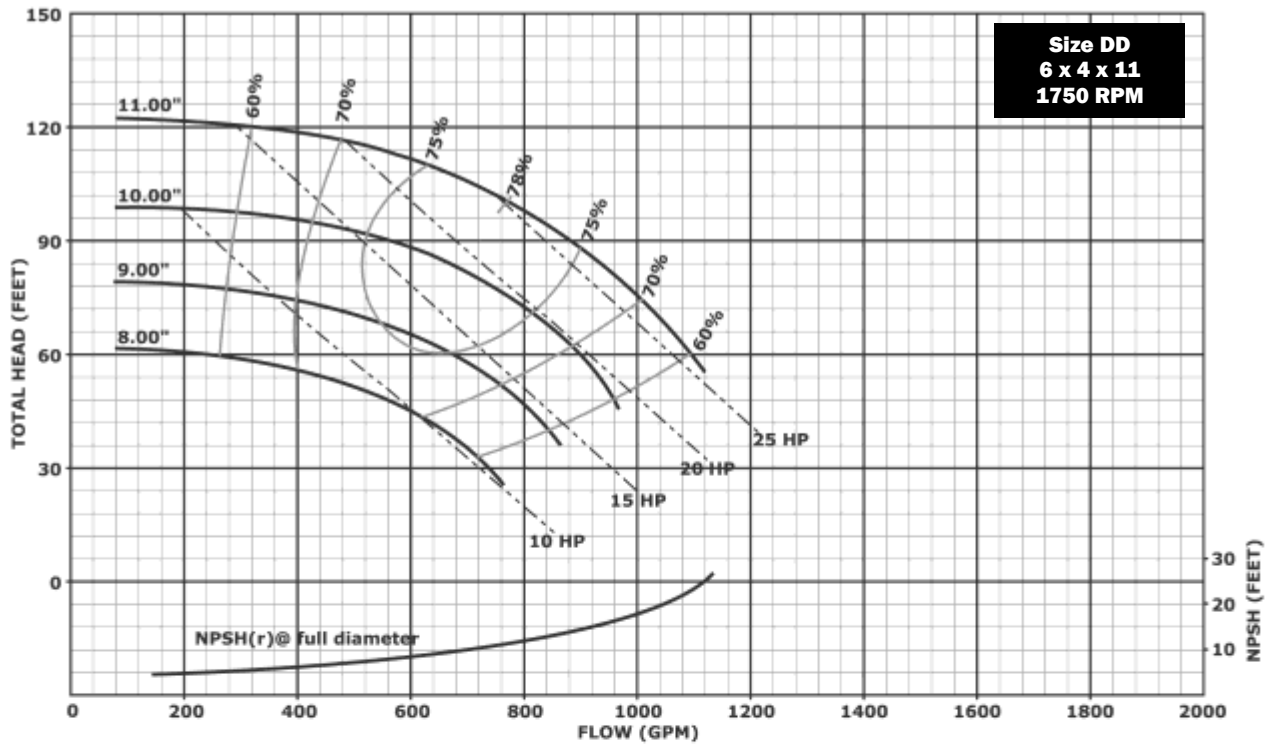

Notes:

1. Above data is based on 1.0 sp. gr. water at ambient temperature and pressure in accordance with Hydraulic Institute guidelines.
2. Impeller diameters between minimum and maximum shown are available in 1/8 inch increment trims.
3. For special G2S power requirements at start up refer to Table 1.13.

Hydraulic Performance - 13 Inch Impellers @ 1750 RPM

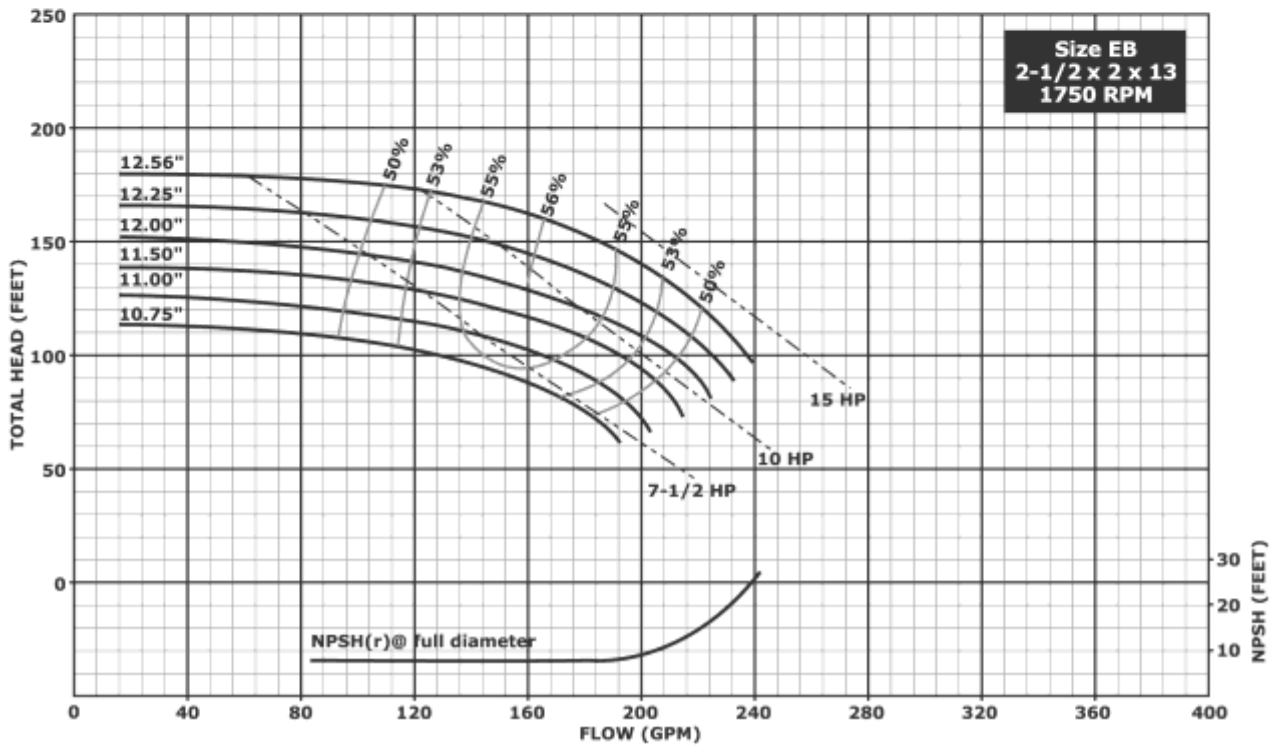
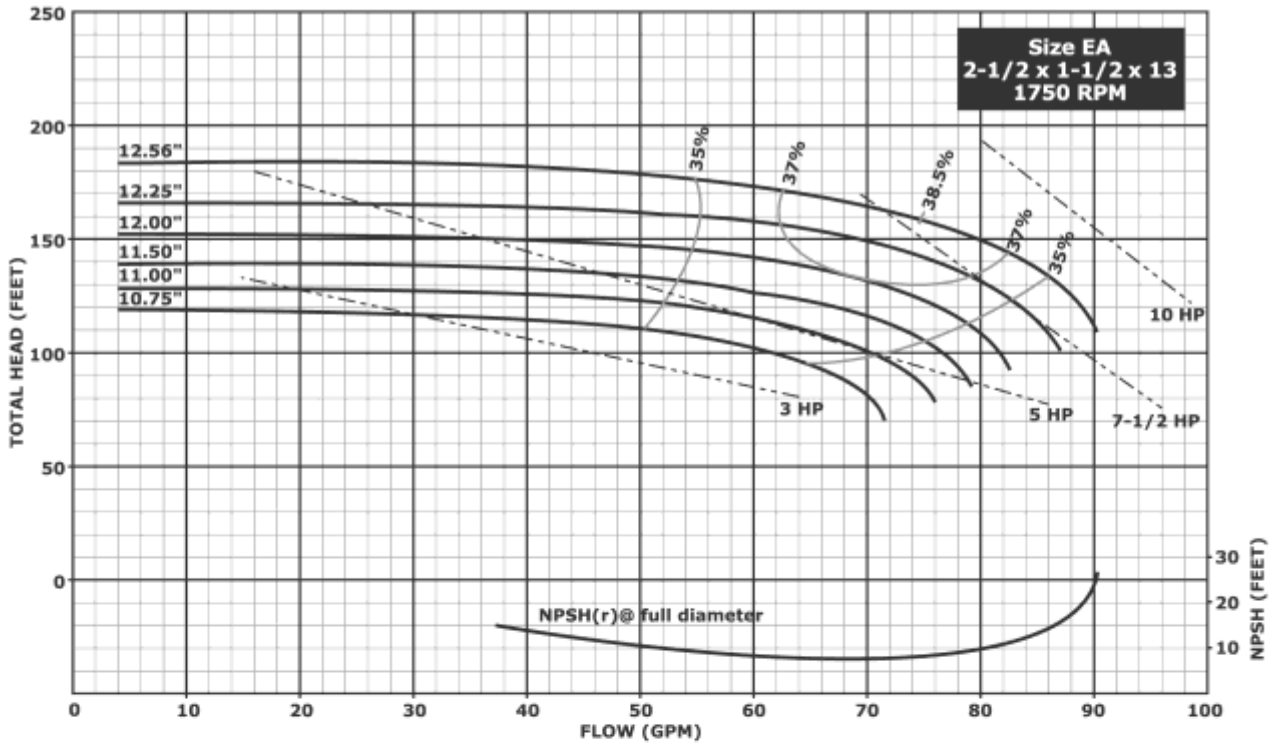

Notes:

1. Above data is based on 1.0 sp. gr. water at ambient temperature and pressure in accordance with Hydraulic Institute guidelines.
2. Impeller diameters between minimum and maximum shown are available in 1/8 inch increment trims.
3. For special G2S power requirements at start up refer to Table 1.13.

Hydraulic Performance - 13 Inch Impellers

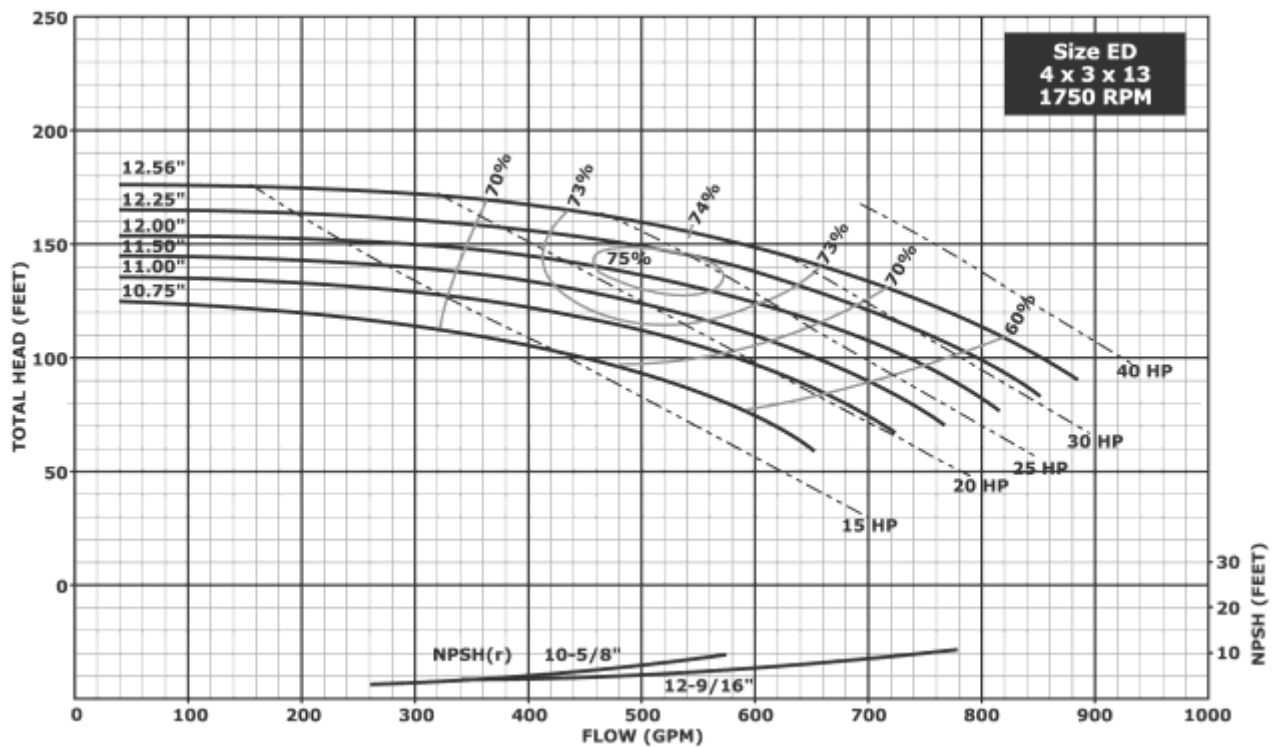
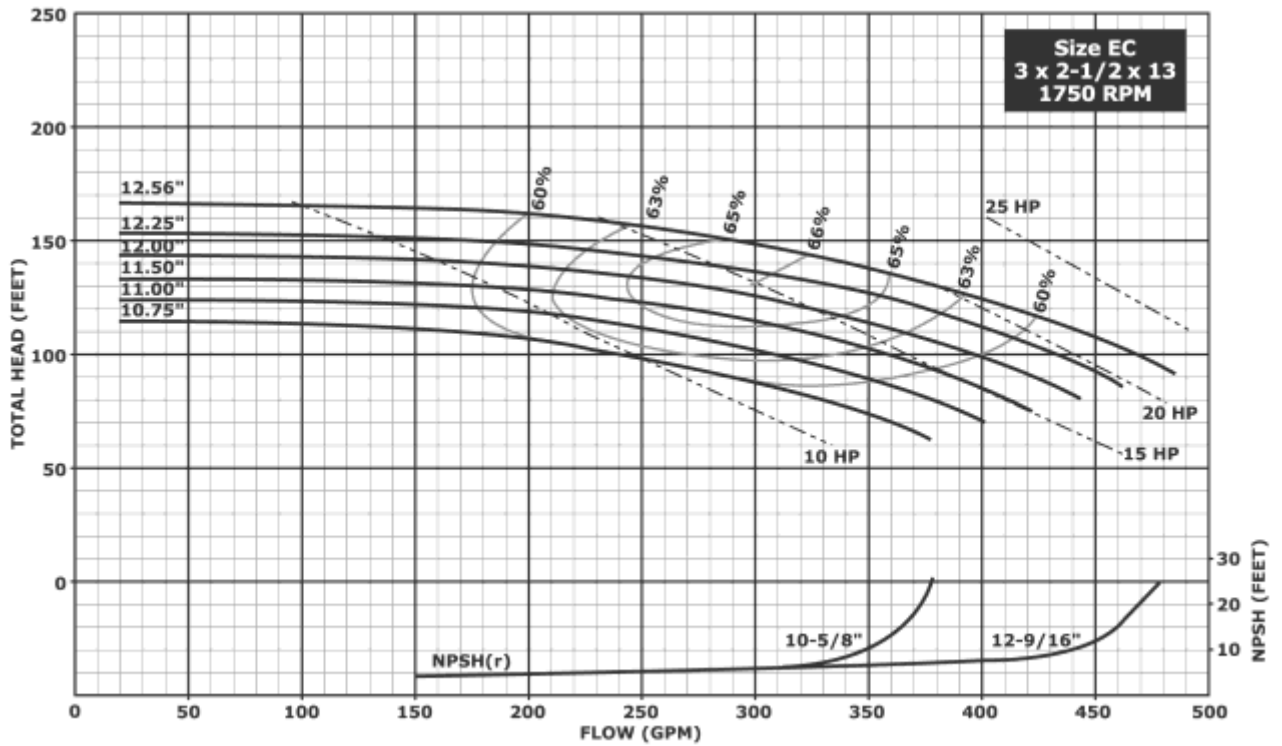

Notes:

1. Above data is based on 1.0 sp. gr. water at ambient temperature and pressure in accordance with Hydraulic Institute guidelines.
2. Impeller diameters between minimum and maximum shown are available in 1/8 inch increment trims.
3. For special G2S power requirements at start up refer to Table 1.13.

Hydraulic Performance - 13 Inch Impellers

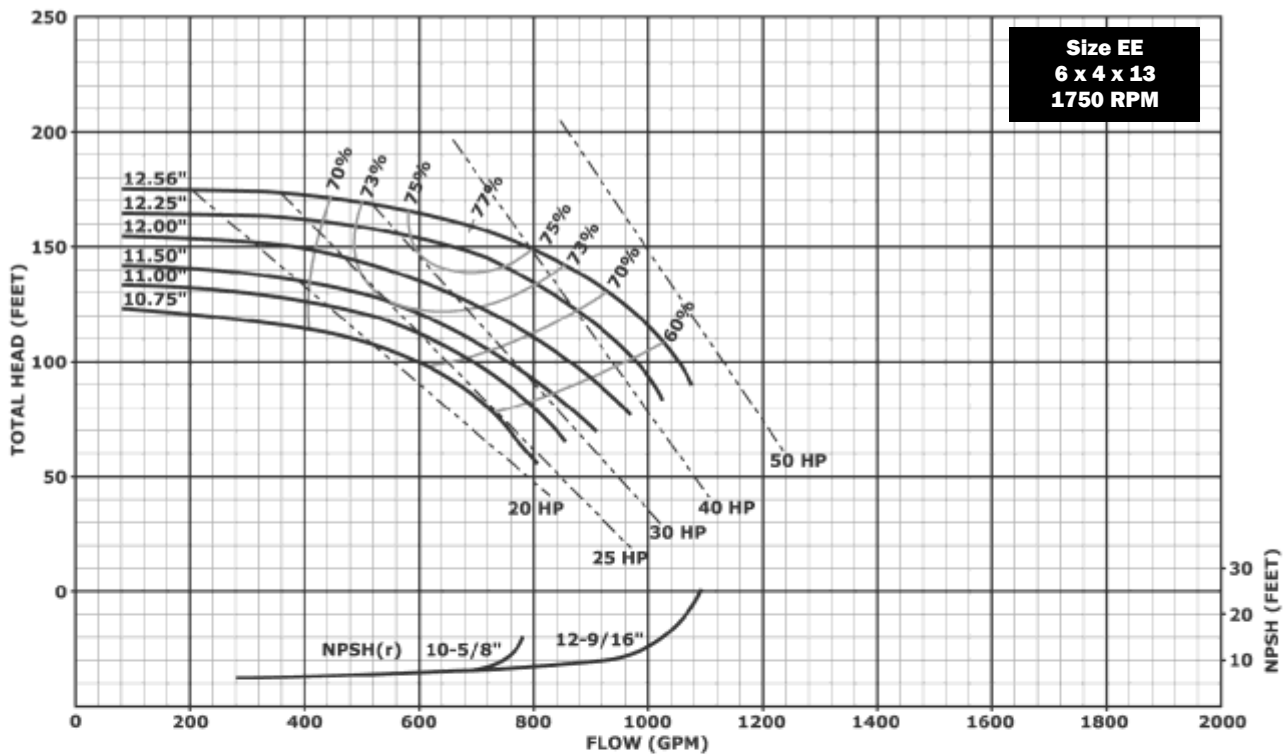

Notes:

1. Above data is based on 1.0 sp. gr. water at ambient temperature and pressure in accordance with Hydraulic Institute guidelines.
2. Impeller diameters between minimum and maximum shown are available in 1/8 inch increment trims.
3. For special G2S power requirements at start up refer to Table 1.13.

1.13 Special Power Considerations for the G2S.

To allow for lineshaft bearing friction losses sometimes encountered in startup (i.e., potentially dry run) situations, we recommend the following power requirements be added to those shown on the Hydraulic Performance curves.

G2S Dry Lineshaft Bearing Friction Losses	
Column Depth	Added Dry Start Up Losses
4 to 10 ft.	0.50 BHP
10 to 16 ft.	0.75 BHP
16 to 20 ft.	1.00 BHP
over 20 ft.	1.25 BHP

G2C - 7" and 10" Impeller Sizes (Without Discharge Pipe)

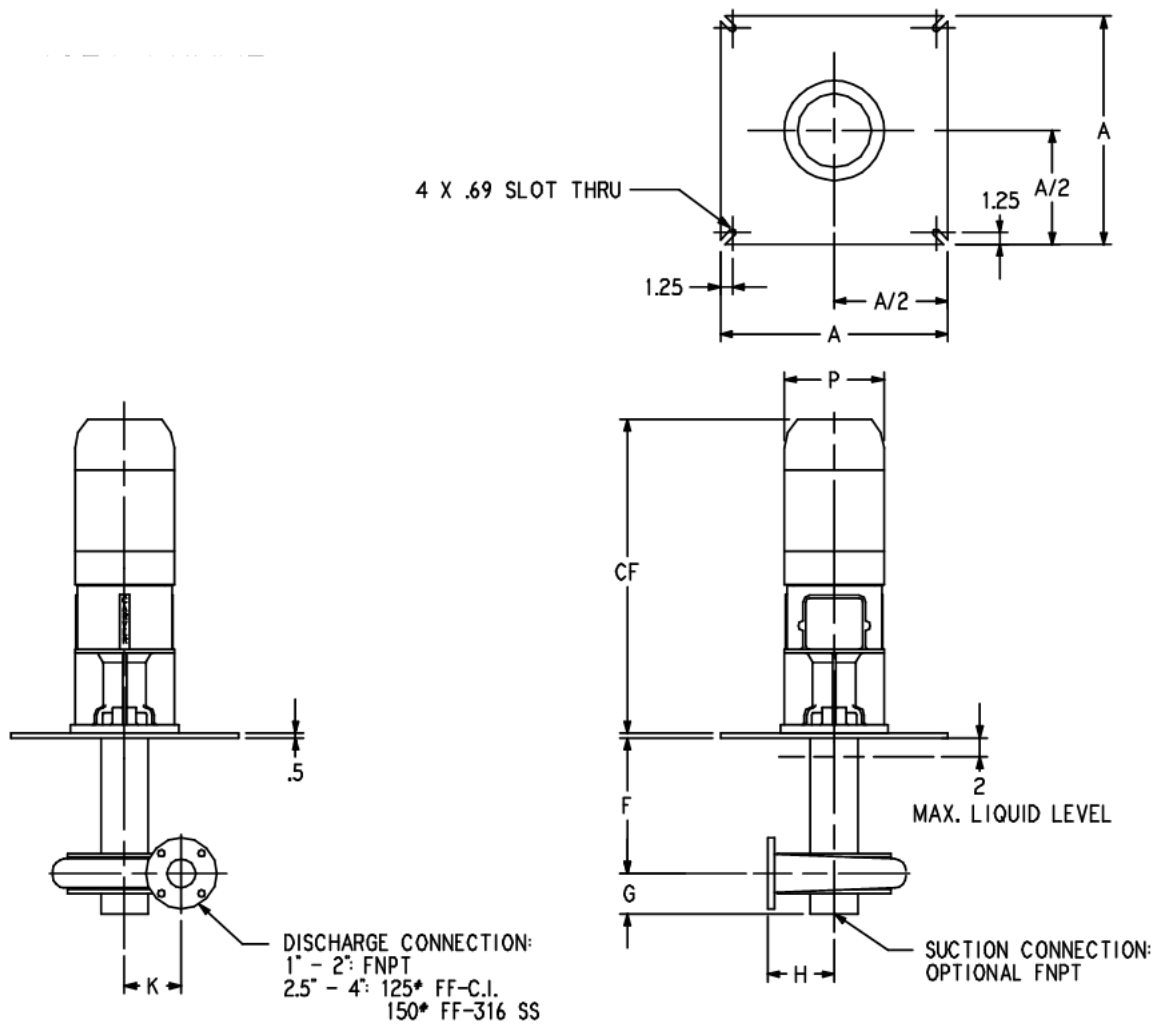

Pump Size	Pump Dimensions						
	A	F		G	H	K	Bearing Frame
		Standard	Extended				
1 1/4 x 1 x 7	18.0	14.8	26.8	2.7	4.3	3.8	1521
1 1/2 x 1 1/4 x 7	18.0	14.4	26.4	2.8	4.5	4.0	
2 1/2 x 2 x 7	18.0	14.3	26.3	3.7	5.0	4.1	
3 x 2 1/2 x 7	24.0	14.3	26.3	4.0	5.8	4.3	
3 x 3 x 7	24.0	14.5	26.5	4.8	6.0	4.5	
4 x 4 x 7	24.0	14.4	26.4	5.0	7.5	4.8	
1 1/2 x 1 1/4 x 10	18.0	14.2	26.2	3.3	6.0	5.3	1521
2 x 1 1/2 x 10	18.0	14.3	26.3	3.5	6.0	5.4	
2 1/2 x 2 x 10	18.0	14.4	26.4	4.3	6.3	5.5	
3 x 2 1/2 x 10	24.0	14.4	26.4	4.7	7.0	5.8	
4 x 3 x 10	24.0	14.4	26.3	4.6	7.0	6.0	
4 x 4 x 10	24.0	14.4	26.4	4.7	8.5	6.5	
6 x 6 x 10	24.0	15.9	27.9	5.8	8.4	7.6	1532

Motor Dimensions		
NEMA MOTOR FRAME	CF	P
143TC	27.0	7.4
145TC	28.0	7.4
182TC	28.5	9.5
184TC	29.5	9.5
213TC	31.0	11.0
215TC	32.0	11.0
254TC	34.0	13.0
256TC	35.0	13.0
284 TC	41.0	15.0
286 TC	43.0	15.0

Note: NEMA frames 284 / 286 TC available with size 1532 bearing frame only.

	1. All dimensions in inches, all tolerances +/- 0.125 inch.	Dwg: SP-G2V-1
	2. All motor dimensions are approximate.	
	3. Not valid for construction unless certified.	

G2C - 7" and 10" Impeller Sizes (With Discharge Pipe)

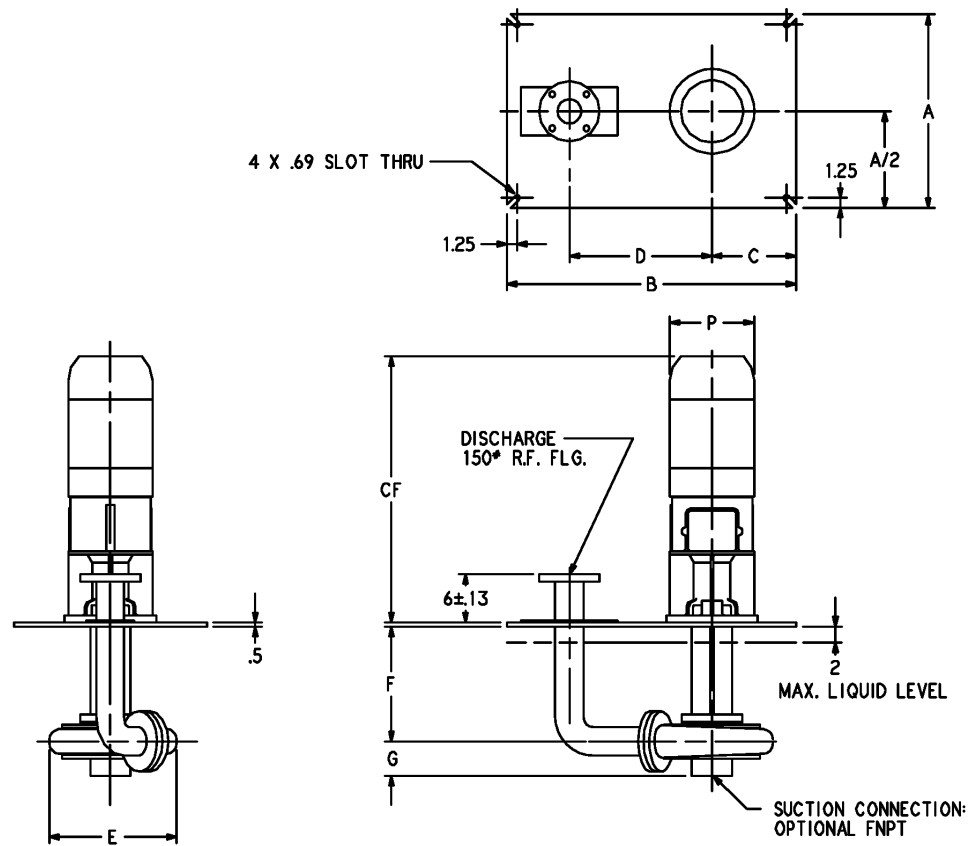

Pump Size	Pump Dimensions											Bearing Frame
	Discharge Pipe		A	B	C	D		E	F		G	
	Standard	Oversized				Standard	Oversized		Standard	Extended		
1 ¼ x 1 x 7	2	-	18.0	24.0	8.5	12.2	-	8.8	14.8	26.8	2.7	1521
1 ½ x 1 ¼ x 7	2	-	18.0	24.0	8.5	12.4	-	8.9	14.4	26.4	2.8	
2 ½ x 2 x 7	2	2 ½	18.0	24.0	8.5	10.8	11.4	10.3	14.3	26.3	3.7	
3 x 2 ½ x 7	2 ½	3	24.0	36.0	10.5	17.3	17.3	10.6	14.3	26.3	4.0	
4 x 3 x 7	3	4	24.0	36.0	10.5	17.3	17.3	11.0	14.5	26.5	4.8	
4 x 4 x 7	4	6	24.0	36.0	10.5	17.3	17.3	11.8	14.4	26.4	5.0	1521
1 ½ x 1 ¼ x 10	2	-	18.0	24.0	8.5	12.5	-	13.3	14.2	26.2	3.3	
2 x 1 ½ x 10	2	-	18.0	24.0	8.5	12.1	-	12.6	14.3	26.3	3.5	
2 ½ x 2 x 10	2	2 ½	18.0	24.0	8.5	12.5	12.6	12.8	14.4	26.4	4.3	
3 x 2 ½ x 10	2 ½	3	24.0	36.0	10.5	17.3	17.3	13.3	14.4	26.4	4.7	
4 x 3 x 10	3	4	24.0	36.0	10.5	17.3	17.3	14.5	14.4	26.4	4.6	
4 x 4 x 10	4	6	24.0	36.0	10.5	19.0	19.0	16.0	14.4	26.4	4.7	1532
6 x 6 x 10	6	-	24.0	36.0	12.0	18.8	18.8	18.5	15.9	27.9	5.8	



1. All dimensions in inches, all tolerances +/- 0.125 inch.
2. For motor dimensions CF and P see prior page.
3. Not valid for construction unless certified.

Dwg: SP-G2V-2

G2C - 11" and 13" Impeller Sizes (Without Discharge Pipe)

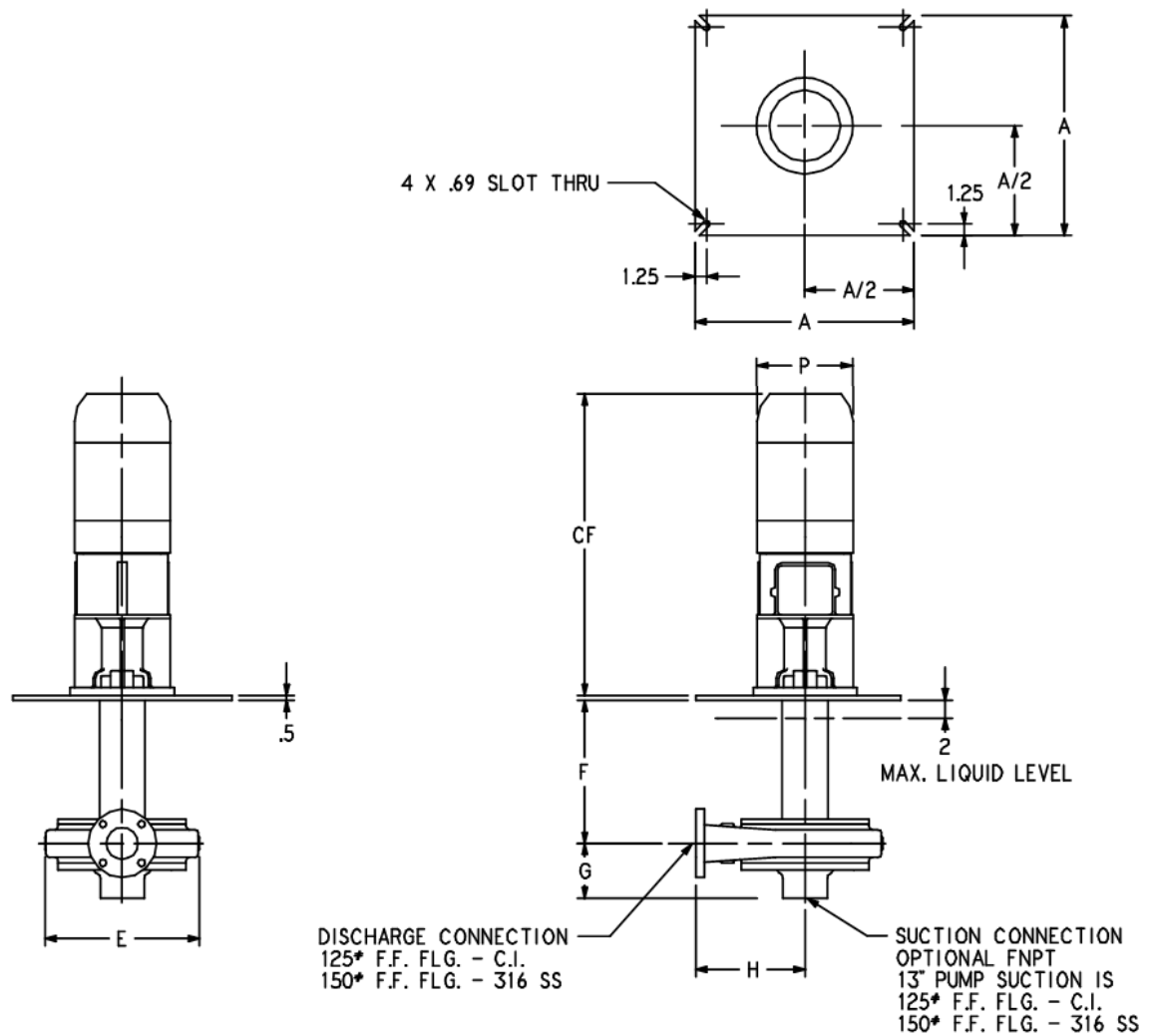

Pump Size	Pump Dimensions						Bearing Frame
	A	E	F		G	H	
			Standard	Extended			
2 x 1 x 11	24.0	14.5	14.9	26.9	3.9	11.0	1532
4 x 2 x 11	24.0	15.5	14.9	26.9	6.0	11.0	
4 x 3 x 11	24.0	17.0	14.9	26.9	6.0	12.0	
6 x 4 x 11	24.0	16.5	15.7	27.7	6.0	10.8	
8 x 6 x 11	30.0	22.0	15.3	27.3	6.5	16.0	
2 ½ x 1 ½ x 13	24.0	15.5	14.4	26.4	4.9	9.8	1521
2 ½ x 2 x 13	24.0	16.0	14.4	26.4	4.9	11.0	
3 x 2 ½ x 13	24.0	17.0	14.4	26.4	4.9	11.0	1532
4 x 3 x 13	24.0	17.0	14.4	26.4	4.9	12.4	
6 x 4 13	24.0	18.0	14.4	26.4	5.5	12.4	

Motor Dimensions		
NEMA MOTOR FRAME	CF	P
143 / 145 TC	27.0 / 28.0	7.4
182 / 184 TC	28.5 / 29.5	9.5
213 / 215 TC	31.0 / 32.0	11.0
254 / 256 TC	34.0 / 35.0	13.0
284 / 286 TC	41.0 / 43.0	15.0
324 / 326 TC	45.0 / 46.0	17.0

	1. All dimensions in inches, all tolerances +/- 0.125 inch. 2. All motor dimensions are approximate. 3. Not valid for construction unless certified.	Dwg: SP-G2V-3
	(Empty space for additional notes)	

G2C - 11" and 13" Impeller Sizes (With Discharge Pipe)

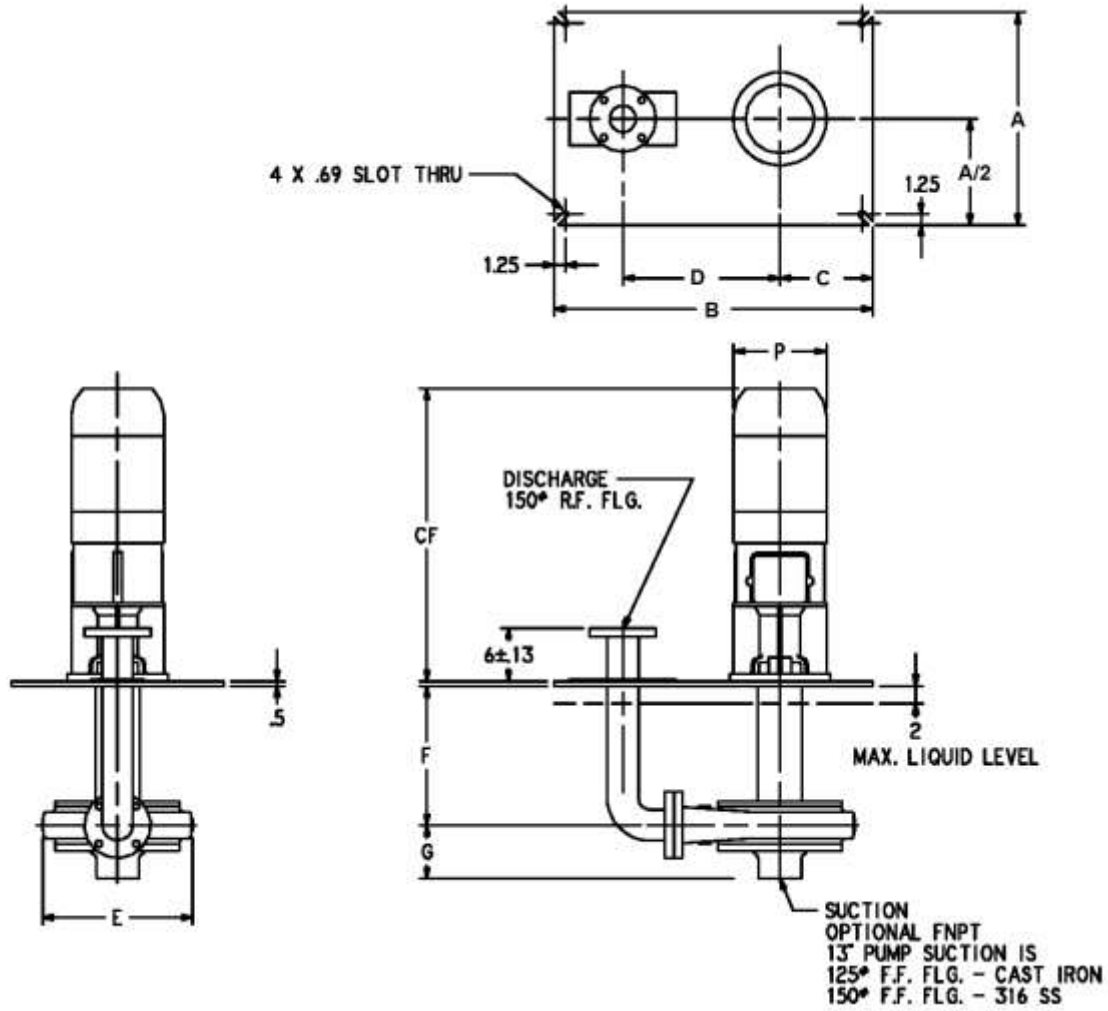

Pump Size	Pump Dimensions											Bearing Frame
	Discharge Pipe		A	B	C	D		E	F		G	
	Standard	Oversized				Standard	Oversized		Standard	Extended		
2 x 1 x 11	2	-	24.0	36.0	12.0	18.0	18.0	14.5	14.9	26.9	3.9	1521
4 x 2 x 11	2	2 ½	24.0	36.0	12.0	18.0	18.0	15.5	14.9	26.9	6.0	
4 x 3 x 11	3	4	24.0	36.0	12.0	18.0	18.0	17.0	14.9	26.9	6.0	
6 x 4 x 11	4	6	24.0	36.0	12.0	18.0	18.0	16.5	15.7	27.7	6.0	1532
8 x 6 x 11	6	8	30.0	45.0	13.0	25.0	24.0	22.0	15.3	27.3	6.5	
2 ½ x 1 ½ x 13	2	-	24.0	36.0	12.0	18.0	18.0	15.5	14.4	26.4	4.9	1521
2 ½ x 2 x 13	2	2 ½	24.0	36.0	12.0	18.0	18.0	16.0	14.4	26.4	4.9	
3 x 2 ½ x 13	2 ½	3	24.0	36.0	12.0	18.0	18.0	17.0	14.4	26.4	4.9	1532
4 x 3 x 13	3	4	24.0	36.0	12.0	18.0	18.0	17.0	14.4	26.4	4.9	
6 x 4 x 13	4	6	24.0	36.0	12.0	18.0	18.0	18.0	14.4	26.4	5.5	

	<ol style="list-style-type: none"> All dimensions in inches, all tolerances +/- 0.125 inch. For motor dimensions CF and P see prior page. Not valid for construction unless certified. 	Dwg: SP-G2V-4
--	---	----------------------

G2S - 7" and 10" Impeller Sizes

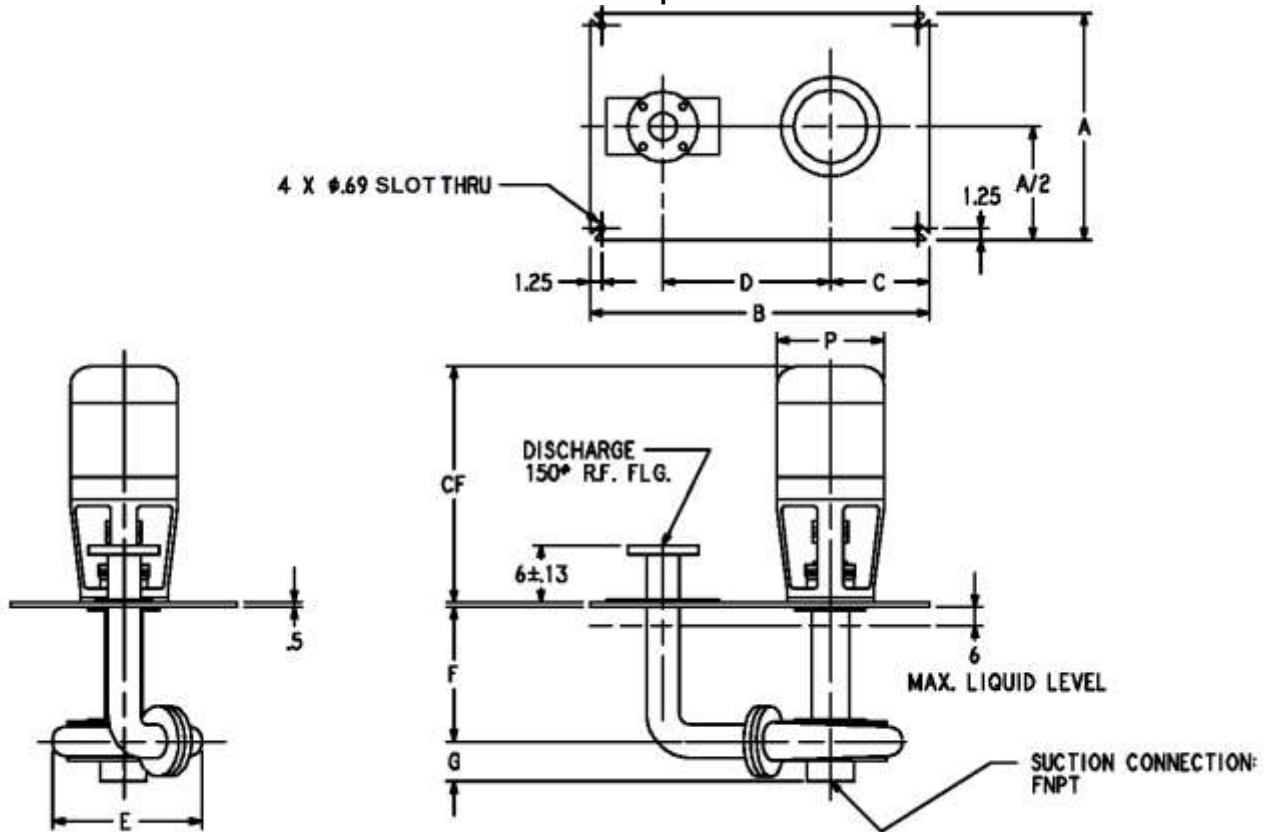

Pump Size	Pump Dimensions							
	Discharge Size	A	B	C	D	E	F (See note below)	G
1 1/4 x 1 x 7	2	18.0	24.0	8.5	12.5	8.8	6.3 + column depth	2.7
1 1/2 x 1 1/4 x 7	2	18.0	24.0	8.5	12.4	8.9	5.9 + column depth	2.8
2 1/2 x 2 x 7	2	18.0	24.0	8.5	10.8	10.3	5.9 + column depth	3.7
3 x 2 1/2 x 7	2 1/2	24.0	36.0	10.5	17.2	10.6	5.9 + column depth	4.0
3 x 3 x 7	3	24.0	36.0	10.5	17.2	11.0	6.1 + column depth	4.8
4 x 4 x 7	4	24.0	36.0	10.5	17.2	11.8	6.0 + column depth	5.0
1 1/2 x 1 1/4 x 10	2	18.0	24.0	8.5	12.5	13.3	5.7 + column depth	3.3
2 x 1 1/2 x 10	2	18.0	24.0	8.5	12.6	12.6	5.9 + column depth	3.5
2 1/2 x 2 x 10	2	18.0	24.0	8.5	12.5	12.8	5.9 + column depth	4.0
3 x 2 1/2 x 10	2 1/2	24.0	36.0	10.5	13.2	13.3	5.9 + column depth	4.7
4 x 3 x 10	3	24.0	36.0	10.5	14.5	14.5	5.9 + column depth	4.6
4 x 4 x 10	4	24.0	36.0	10.5	16.0	16.0	5.9 + column depth	4.7
6 x 6 x 10	6	30.0	45.0	13.0	20.5	20.5	8.4 + column depth	5.8

Motor Dimensions (Approx.)		
NEMA MOTOR FRAME	CF	P
143TC	21.0	7.4
145TC	22.0	7.4
182TC	25.0	9.5
184TC	26.0	9.5
213TC	28.0	11.0
215TC	29.0	11.0
254TC	31.0	13.0
256TC	32.0	13.0
284 TC	34.0	15.0
286 TC	35.0	15.0

Note: NEMA frames 284 / 286 TC available with size 1532 bearing frame only.

	<ol style="list-style-type: none"> All dimensions in inches, all tolerances +/- 0.125 inch. Dimension "F" equal to values shown plus nominal column depth in increments of 12 inches (3.0 foot min, 20.0 foot max.). Not valid for construction unless certified. 	<p>Dwg: SP-G2V-5</p>
--	--	----------------------

G2S - 11" and 13" Impeller Sizes

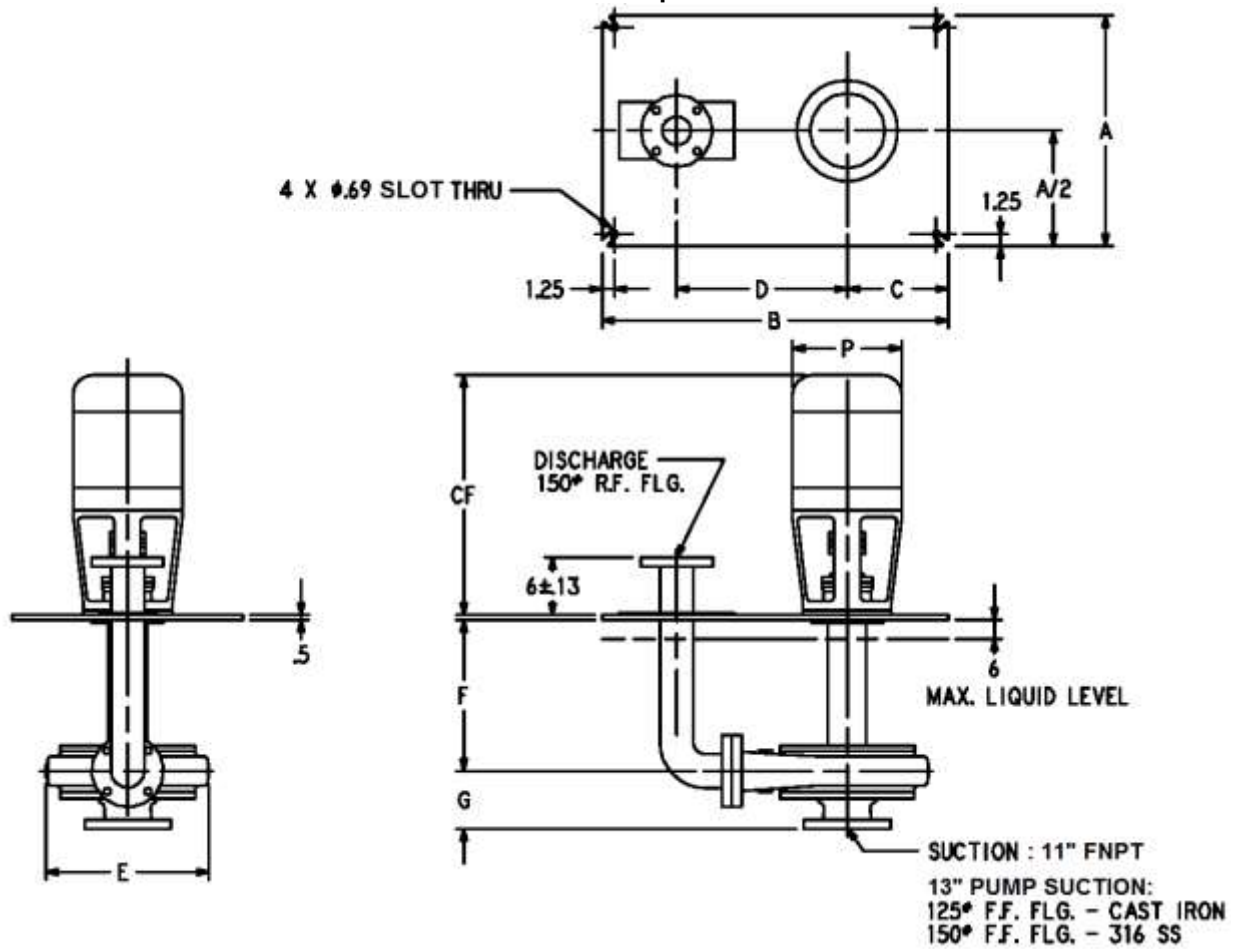

Pump Size	Pump Dimensions							
	Discharge Size	A	B	C	D	E	F (See note below)	G
2 x 1 x 11	2	24.0	36.0	12.0	18.0	14.5	6.5 + column depth	3.9
4 x 2 x 11	2	24.0	36.0	12.0	18.0	15.5	6.5 + column depth	6.0
4 x 3 x 11	3	24.0	36.0	12.0	18.0	17.0	6.5 + column depth	6.0
6 x 4 x 11	4	24.0	36.0	12.0	18.0	16.5	8.2 + column depth	6.0
8 x 6 x 11	6	30.0	45.0	13.0	25.0	22.0	7.8 + column depth	6.5
2 ½ x 1 ½ x 13	2	26.0	40.0	13.0	20.0	15.5	5.9 + column depth	4.9
2 ½ x 2 x 13	2	26.0	40.0	13.0	20.0	16.0	5.9 + column depth	4.9
3 x 2 ½ x 13	2 ½	26.0	40.0	13.0	20.0	17.0	6.9 + column depth	4.9
4 x 3 x 13	3	26.0	40.0	13.0	20.0	17.0	6.9 + column depth	4.9
6 x 4 x 13	4	26.0	40.0	13.0	20.0	18.0	6.9 + column depth	5.5

Motor Dimensions (Approx.)		
NEMA MOTOR FRAME	CF	P
143 / 145 TC	21.0 / 22.0	7.4
182 / 184 TC	25.0 / 26.0	9.5
213 / 215 TC	28.0 / 29.0	11.0
254 / 256 TC	31.0 / 32.0	13.0
284 / 286 TC	34.0 / 35.0	15.0
324 / 326 TC	37.0 / 38.0	17.0
364 / 365 TC	39.0 / 40.0	20.0
404 / 405 TC	43.0 / 45.0	22.0

	1. All dimensions in inches, all tolerances +/- 0.125 inch.	Dwg: SP-G2V-6
	2. Dimension "F" equal to values shown plus nominal column depth in increments of 12 inches (3.0 foot min, 20.0 foot max.).	
	3. Not valid for construction unless certified.	

Suction Strainer and Inlet Tailpipe Dimensions

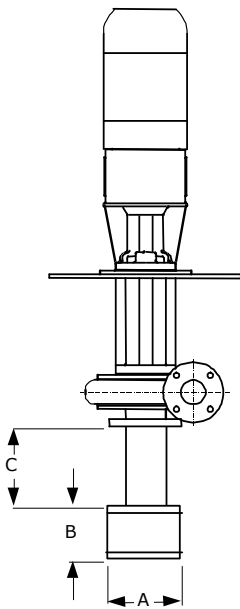

Inlet Size	Suction Strainer and Tailpipe Dimensions				
	Inlet Pipe Connection	Mesh Opening	A	B	C
1¼	NPT	0.375	5.00	3.50	5.25 (+/- 0.25)
1½		0.375	5.00	4.00	
2		0.375	6.00	4.00	
2½		0.375	6.00	4.00	
3		0.375	7.00	5.00	
4		0.375	7.00	5.00	
6		0.375	9.00	9.00	
8		1.000	11.0	11.0	
3	ANSI Flange	0.375	7.00	5.00	6.25 (+/- 0.25)
4		0.375	7.00	5.00	
6		0.375	9.00	9.00	
8		1.000	11.0	11.0	

Notes:

1. Tailpipe (dimension "C") is with a standard 6" pipe nipple, with effective length varying by the degree of thread (NPT) or socket weld (ANSI flange) engagement.
2. Actual strainer distance above tank bottom is generally recommended to be 0.3 to 0.8 times actual pump inlet nominal diameter – see Section 1.10, page 5.
3. Dimensions in above table apply to G2V (G2C and G2S) Series pumps.

G2S Extended Shaft Length Details



All G2S pumps incorporate renewable intermediate lineshaft bearings for positive shaft support and to avoid deflection at critical shaft speeds. Lineshaft bearings are placed at approximately every 4.0 foot of column length.

For shaft lengths in excess of 10 feet, a two-piece shaft design with rigid coupling is also used – see diagram at left. The basic arrangement consists of an upper and lower shaft, shaft coupling, upper and lower coupling-to-shaft pins, and a gasket situated between the two shaft ends.

All pumps are also provided with a Cast Iron (steel shaft) or Alloy 20 (316 SS shaft) slinger located on the shaft close to the impeller. The slinger deflects pumped fluid away from the shaft and prevents it from entering the column assembly and lineshaft bearing area.

	<ol style="list-style-type: none"> 1. All dimensions in inches, all tolerances +/- 0.125 inch. 2. Not valid for construction unless certified. 	<p>Dwg: SP-G2V-7</p>
--	--	----------------------



Carver Pump Company

2415 Park Avenue • Muscatine, IA 52761

Phone: 563.263.3410 • Fax: 563.262.0510

www.carverpump.com

**G2V SERIES TECH PAGES
NOV 2016**