



**CARVER PUMP™**  
Built for purpose

120 – 17.04.EN

## ***GH – General Horizontal, Close Coupled and Frame Mounted Pumps***

**Technical Specification Pages**

This page left intentionally blank.

**1.0 Overview.**

The GH Series is Carver’s horizontal, end suction pump for handling water, oils, and chemicals in process, marine, and general industrial applications. Available as either a frame mounted (GHF) or close coupled (GHC) unit, the GH is based on the same product platform as our vertical GV Series and shares many of the same parts.

For added simplicity, the GH is covered by only three bearing frames and is available in whole pump or modular kit form. All models are a back pull-out design with removable suction covers and rotatable casings to accommodate different piping orientations.

Other standard features include 316 SS shaft sleeves, keyed impellers for more positive driving and to prevent accidental spin off, dynamic balancing to ISO G2.5 guidelines, and regreasable bearings secured with lock nuts.

The GH is the natural evolution of the L & H, GSH and GSC Series, which it now replaces. While designed for maximum dimensional and parts interchangeability, the GH is nonetheless a new pump series and all parts are not necessarily identical to everything that preceded it. External dimensions, however, are unchanged.

**1.1 Basic Hydraulic Features**

Standard hydraulic features for the GH Series are given in the table below; with the bearing frame designations shown applicable to the GHF (frame mounted) pumps only. All other data is for both the GHF and GHC (close coupled) models.

<b>Basic Hydraulic Features</b>										
Basic Pump Size	General Design Features						Hydraulic Performance			
	Discharge Type	Maximum Solids	Casing Volutes	Connection Type	Bearing Frame	Impeller Type	Max RPM	Max / Min diameter	Specific Speed $N_s$	Suction Sp. Speed $N_{ss}$
AA - 1 ¼ x 1 x 5	Tangential	0.187"	Single	NPT	10 P	Semi-open	3500	5.0" / 3.5"	996	3,303
AB - 2 x 1 ½ x 5		0.250"							1,646	2,450
AC - 2 ½ x 2 x 5		0.313"							1,982	5,181
BA - 1 ¼ x 1 x 7	Tangential	0.187"	Single	NPT	10 P	Enclosed	3500	7.0" / 4.5"	703	2,582
BB - 1 ½ x 1 ¼ x 7		0.218"							894	2,856
BC - 2 ½ x 2 x 7		0.313"		1,143					3,984	
BD - 3 x 2 ½ x 7		0.437"		1,435					6,824	
BE - 4 x 3 x 7		0.562"	2,070	7,937						
BF - 5 x 4 x 7		0.750"	2,091	5,821						
CA - 1 ½ x 1 ¼ x 10		Tangential	0.218"	Single					NPT	20 P
CB - 2 x 1 ½ x 10	0.250"		740		4,811					
CC - 2 ½ x 2 x 10	0.313"		970		3,244					
CD - 3 x 2 ½ x 10	0.437"		1,017		5,018					
CE - 4 x 3 x 10	0.562"		1,311	5,693						
CF - 5 x 4 x 10	0.750"		1,687	5,808						
CG - 6 x 5 x 10	0.875"		2,598	5,635						
DA - 2 x 1 x 11	Centerline		0.437"	Single	Flanged	20 P	Enclosed	3500	11.0" / 8.5"	
DB - 4 x 2 x 11A		0.500"	757							7,584
DF - 4 x 2 x 11B		0.562"	1,061							10,202
DC - 4 x 3 x 11		0.562"	1,061	10,202						
DD - 5 x 4 x 11		0.750"	1,546	8,261						
DE - 8 x 6 x 11		1.250"	2,505	10,693						
EA - 2 ½ x 1 ½ x 13		Centerline	0.131"	Single						Flanged
EB - 2 ½ x 2 x 13	0.313"		519		4,797					
EC - 3 x 2 ½ x 13	0.387"		749		7,274					
ED - 4 x 3 x 13	0.562"		926		9,362					
EE - 5 x 4 x 13	0.750"		1,044		9,734					
EF - 6 x 5 x 13	0.875"		1,435		8,668					
EG - 8 x 6 x 13	1.250"		1,926		11,142					
						30 P				

The GHF is frame mounted and based around three bearing frames. The GHC is close coupled and uses standard NEMA JP or TCZ (West Coast shaft) motor frames for bearing support.



**1.3 Standard Surface Treatment.**

All GH pumps handling liquids less than 230 °F are painted per Carver Standard PA-001. This provides for one coat of Carver Blue, industrial alkyd metal enamel with a 3-5 mils dry film thickness.

All paint is applied over a clean, dry, bare metal surface. All iron castings are spot primed over any area exhibiting minor discoloration from rust or oxidation.

<b>Surface Preparation of Key Components</b>		
<b>Component</b>	<b>Material</b>	<b>Specification</b>
Adaptor bracket	Cast iron	Carver Standard PA-001
	316 SS	N/A
Base and Coupling Guard	Steel	Carver Standard PA-001
	316 SS	N/A
Bearing frame	Cast iron	Carver Standard PA-001
Casing	Steel	Carver Standard PA-001
	Stainless	N/A
Motor	Any	Mfg. Std. Coating

Pumps handling liquids above 230 °F are painted with two coats modified silicone alkyd resin, aluminum colored, to a total of 2 mils dry film thickness.

Since all pumps and parts are assumed to be installed and operated soon after receipt, we do not include any special preservation for long term storage. We also assume no responsibility for storage deterioration after shipment unless explicitly stated in our quotation and purchase order acknowledgment.

Users can also provide their own protection by sealing all ports and openings and coating the pump internals with a water soluble preservative.

**1.4 Material of Construction.**

The standard GH materials and material specifications are given in the table below:

<b>Key Component Materials</b>		
<b>Component</b>	<b>Material</b>	<b>Specification</b>
Bearing Frame	Cast Iron	ASTM A48, Class 30
Casing	Cast Iron	ASTM A48, Class 30
	316 SS	ASTM A744, Grade CF-8M
Impeller	Bronze	ASTM B584, C87500
	Cast Iron	ASTM A48, Class 30
	316 SS	ASTM A744, Grade CF-8M
Motor Bracket	Cast Iron	ASTM A48, Class 30
O-Rings	Elastomer	Viton
Shaft	Carbon Steel	ASTM A108, Grade 1215
Shaft Sleeve	316 SS	ASTM A744, Grade CF-8M
Wear Ring	17-4 PH	ASTM A747, Alloy, CB7Cu-1
Standard Seal	Type 1 or 21	XF1C1 (316) Viton with carbon on ceramic faces, 316 SS metal parts.
Optional Seal	Type 1 or 21	XF10 <sub>56</sub> 1 (316) Viton with carbon on silicon carbide faces, 316 SS metal parts

### 1.5 Key GH Data.

GH pumps use regreasable ball bearings as standard. Compared to other lubrication methods, greased bearings offer:

- lower initial cost
- less maintenance
- better protection from external contaminants

Many of the key GH design parameters are specified in the table below:

<b>Key Mechanical Data</b>			
Item	Bearing Frame		
	10 P	20 P	30 P
Max power (BHP) @ 1750 RPM	20	75	250
@ 3500 RPM	40	150	500
Bearing type - radial bearing	207	210	211
thrust bearing	307	310	5,611
Lubrication method (standard)	Grease		
L <sub>10</sub> bearing life (hrs) - radial	50,000		
thrust	25,000		
Radial to thrust bearing c/l (in.)	6.75	8.50	11.20
Shaft diameter (in.) @ coupling	1.250	1.50	2.000
@ impeller hub	0.875	1.250	1.625
@ radial bearing	1.378	1.968	2.166
@ thrust bearing	1.378	1.968	2.165
@ shaft sleeve	1.000	1.375	1.750
Shaft sleeve outside diameter (in.)	1.250	1.750	2.125
Impeller - thrust bearing c/l (in.)	8.00	9.00	9.63
Rotor WR <sup>2</sup> (lb – in.) – shaft	0.014	0.058	0.126
7" impellers	15.10		
10" impellers	56.67		
11" impellers	137.56		
13" impellers	233.74		

All L<sub>10</sub> bearing lives shown are calculated per ANSI Standard B13.5-1972, and are usually given in each manufacturers' bearing catalog as well.

### 1.6 GH Standard Parts Identification.

Standard parts for frame mounted units with enclosed impellers are shown with the exploded view.

<b>Wet End Parts</b>	
Item	Description
1	Casing
2	Impeller
7	Front Wear Ring
7X	Back Wear Ring
11	Suction Cover
15	Backhead
26	Semi-open Impeller Shim
28	Impeller Washer
32	Impeller Key
73X	Impeller Mounting Gasket
89	O-ring – Backhead/Casing
89A	O-ring – Suction Cover
89C	O-ring – Impeller Cap Screw
422	Plug – Vent, Drain and/or Tap
423	Plug – Stuffing Box Flush
600	Bolt – Backhead/Casing
611	Bolt – Suction Cover/Casing
<b>Adaptor Kit</b>	
Item	Description
71	Adaptor
601	Bolt – Adaptor/Backhead
605	Bolt – Adaptor/Bearing Frame
<b>Mechanical Seal Kit</b>	
Item	Description
41	Shaft Sleeve
17	Gland
40	Slinger
68	Mechanical Seal Spacer
73	Sleeve Gasket
89X	O-ring – Shaft Sleeve
90	Mechanical Seal Assembly
615	Nut – Gland/Backhead
630	Stud – Gland/Backhead
645	Washer – Gland/Backhead
<b>Bearing Frame Parts</b>	
Item	Description
6	Shaft
16	Radial Ball Bearing
18	Thrust Ball Bearing
19	Bearing Frame
22	Bearing Locknut
35	Bearing Cap – Inboard
46	Shaft Key
69	Bearing Lockwasher
76	Grease Fitting
608	Bolt – Bearing Cap/Frame

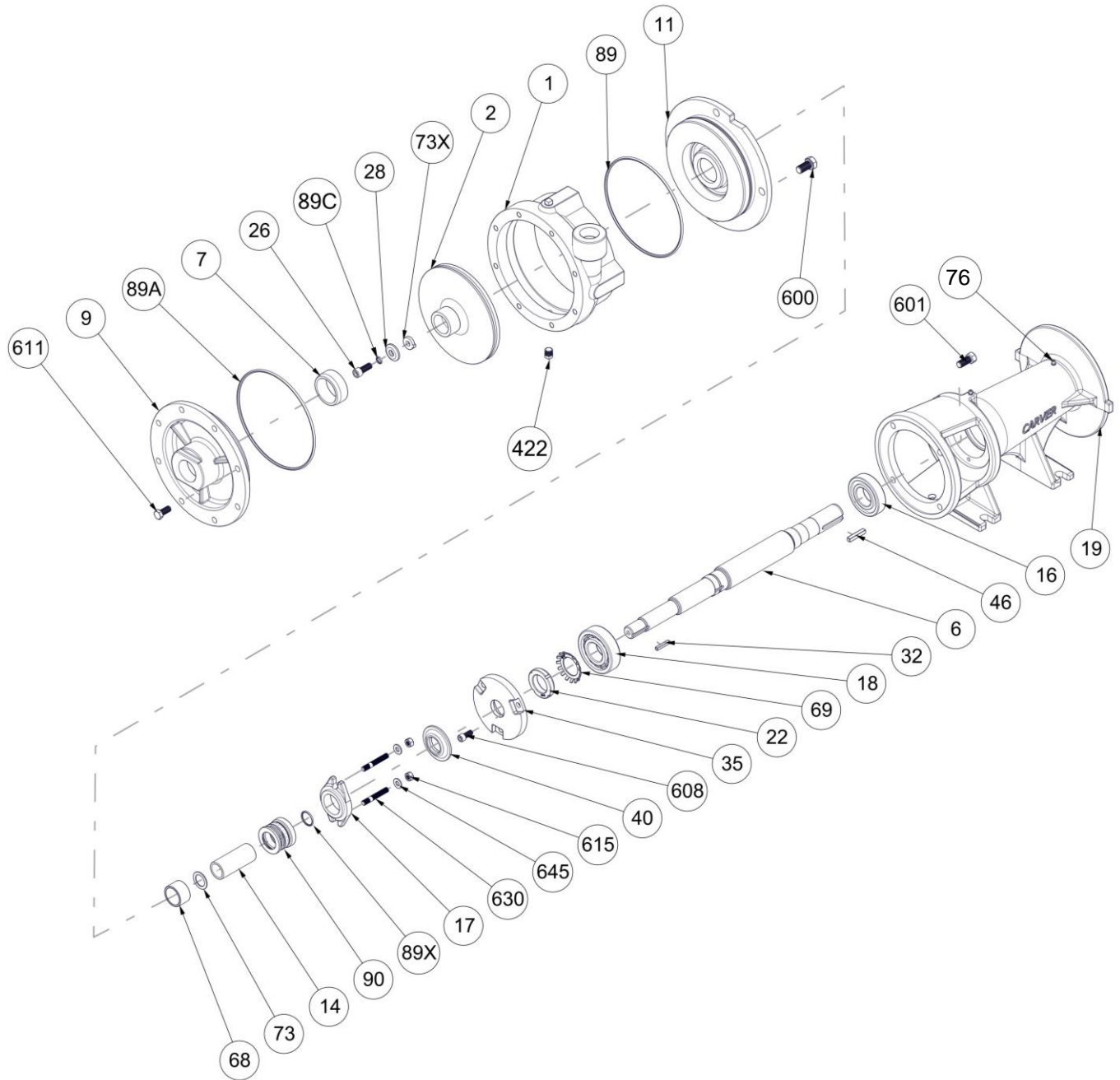

Close coupled units use a NEMA JP frame motor in lieu of the bearing frame assembly shown and pumps with semi-open impellers will have slightly different construction. For further detailed descriptions, material designations and/or quantities for the items shown refer to the GH Series Price book, Section 3.

### 1.7 A Typical GH Specification (Specifier's options in parentheses)

Each pump shall be a horizontal, end suction, frame mounted (close coupled) centrifugal pump capable of developing (2,500) US GPM at a total head of (150) feet when pumping (water) at a temperature of (125) °F with a fluid specific gravity of (1.00) without the use of special clearances, materials, or other internal or external modifications. In meeting these hydraulic conditions, the pump shall have an NPSH requirement of not more than (10) feet and a hydraulic operating efficiency at the normal duty point of at least (70.0)% as defined by the Hydraulic Institute Level A requirements, which includes all mechanical seal and/or bearing losses.

The pump shall include separate liquid end, mechanical seal, and bearing frame sections for ease of maintenance. The liquid end shall be cast iron (316 stainless steel), with all components fully compatible with the temperature, corrosion and abrasion properties of the pumped fluid. All pressure retaining parts of the pump shall be hydrostatically tested to 150% of its operating pressure and all piping connections shall be NPT threaded connections for discharge connections up to and including 2" nominal pipe size, and ANSI 150 lb flanges for all larger sizes. The entire assembly shall be secured to a mounting plate with a minimum of four steel (17-4 PH stainless steel) tie down bolts to assure complete hydraulic and structural integrity of the unit.

The impellers shall be precision, enclosed type cast iron (bronze, 316 stainless steel) for highest efficiency without the need for axial adjustments to compensate for wear as is typical with other impeller types. The impellers shall also be positively keyed to the pump drive shaft for more positive driving and to prevent the impeller from spinning off the shaft and damaging itself and/or the pump casing in the event of accidental reverse rotation. As a further means of assuring longer component life, all impellers shall be dynamically balanced in accordance with ISO G2.5 guidelines. The drive shaft shall be Grade 1215 steel with a replaceable 316 stainless steel sleeve for added protection from erosion and corrosion over the life of the pump.

The bearing frame shall consist of a minimum of two matched grease-lubricated ball bearings to handle all radial and axial loads. The thrust bearing shall have a minimum L10 life of 25,000 hours and the radial bearing shall have a minimum L10 life of 50,000 hours. The bearings shall be grease lubricated and secured to the shaft with threaded locknuts, rather than snap rings, to eliminate any axial movement at the seal faces or impeller-to-casing clearances. The bearings, together with the shaft, shall be designed to provide minimum deflection throughout the entire range of pump operation. In all cases, the shaft deflection shall meet or exceed the requirements of ANSI Specification B73.1M-1991, "Specification for Horizontal End Suction Centrifugal Pumps for Chemical Process."



The pump shall have one mechanical seal and be capable of accepting either component or cartridge-type mechanical seals. The seals shall have Viton elastomers, 316 stainless steel metal components, carbon on ceramic (silicon carbide) faces, and capable of operating up to 230 °F without external cooling. When conditions warrant, the pump shall also be equipped with a 316 stainless steel balance line to facilitate flushing and cooling in the stuffing box area of the pump.

For added ease of operation, the entire pump casing shall be rotatable in 90° increments to accommodate different field piping orientations and shall be the back pull-out type to allow disassembly, inspection, and assembly without otherwise disturbing the pump mounting or system piping.

The pump shall be supplied complete with a baseplate, coupling, and coupling guard. If an electric motor is also provided, it shall be sized to operate throughout the entire range of the pump performance curve without exceeding the nameplate horsepower rating of the motor. In all cases, the pump shall be a heavy-duty industrial design, GH Series as manufactured by the Carver Pump Company of Muscatine, Iowa, or ISO-9001 certified, United States manufactured approved equal.

**1.8 GH Hydraulic Coverage and Performance by Individual Size.**

GH hydraulic performance extends to 2,500 GPM and 520 feet of head. This range is covered by twenty-eight sizes in cast iron, bronze fitted, 316 SS fitted cast iron, or all 316 stainless steel construction.

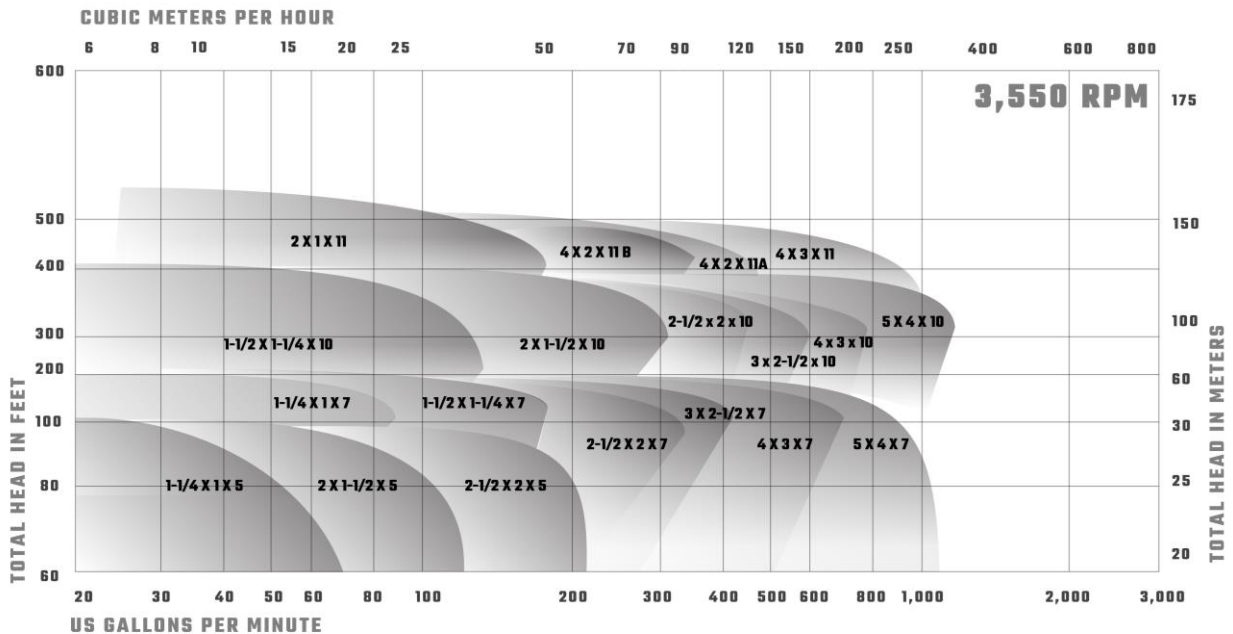
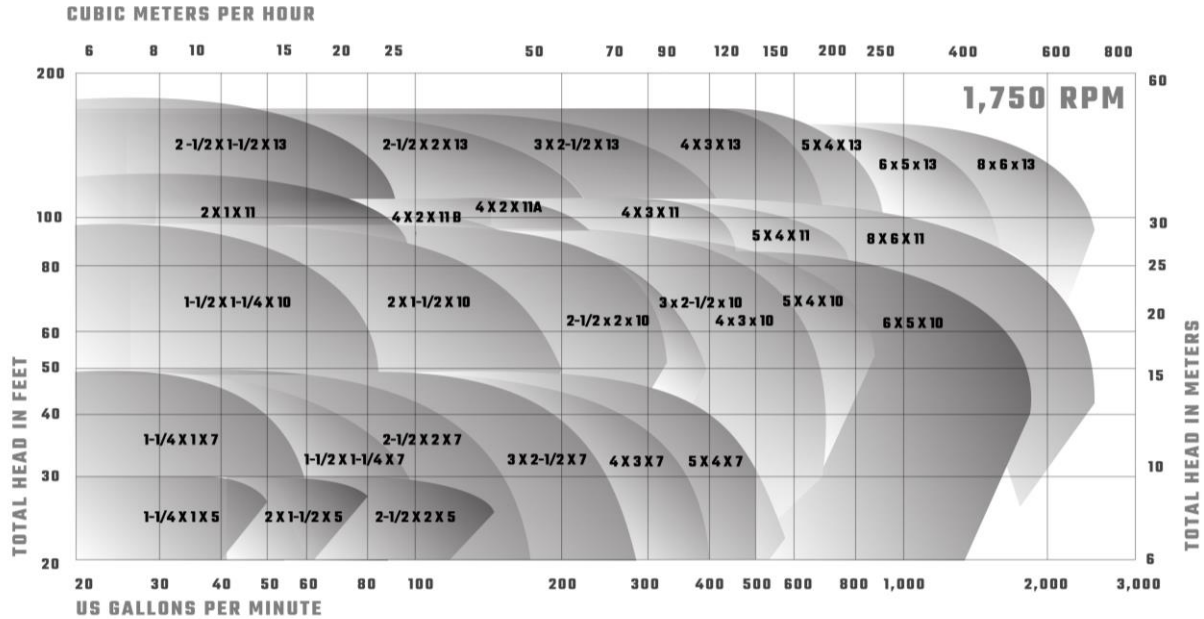

All 5", 7", and 10" pumps with 2" or smaller discharges have NPT connections. All other sizes have ANSI flat face 125 lb. (cast iron) or 150 lb. (316 SS) flanges. All 316 stainless steel pumps with enclosed impellers (i.e., larger than 5") have replaceable wear rings.

**Hydraulic Performance – 5" Impeller Pumps**

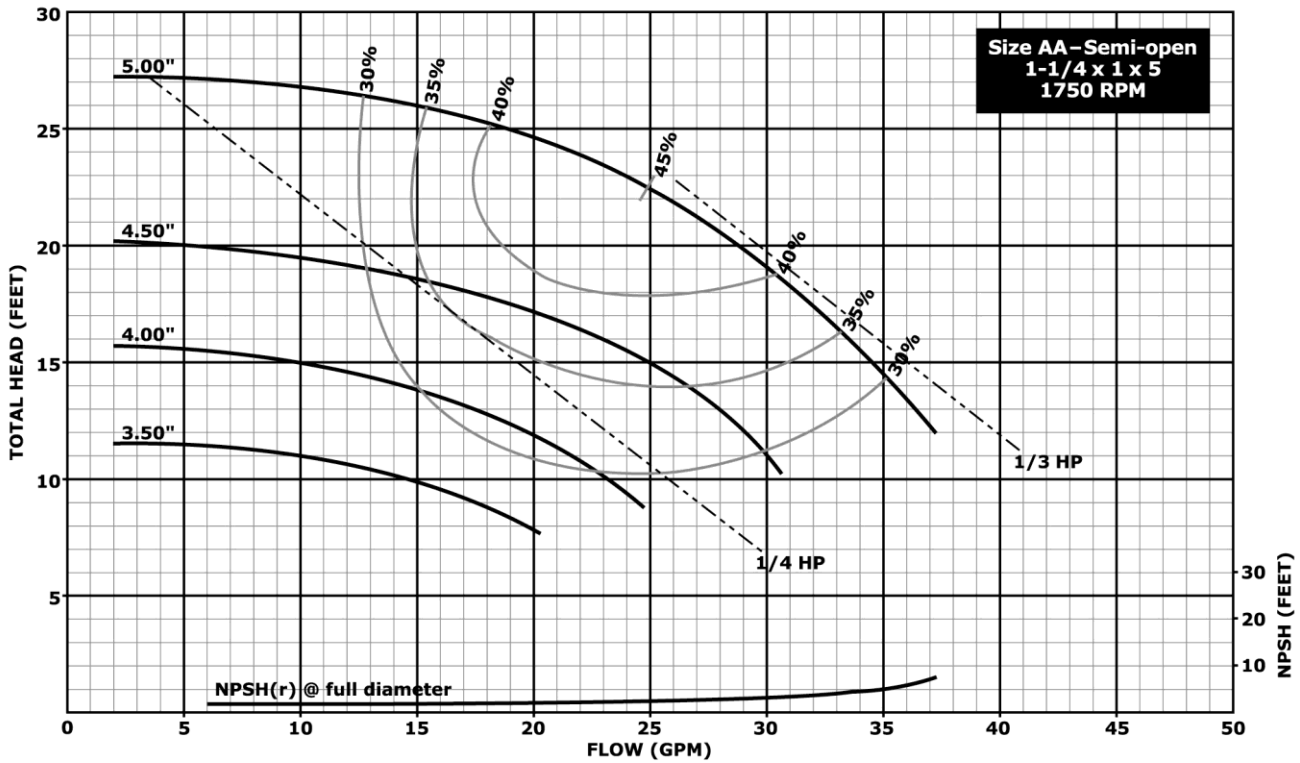
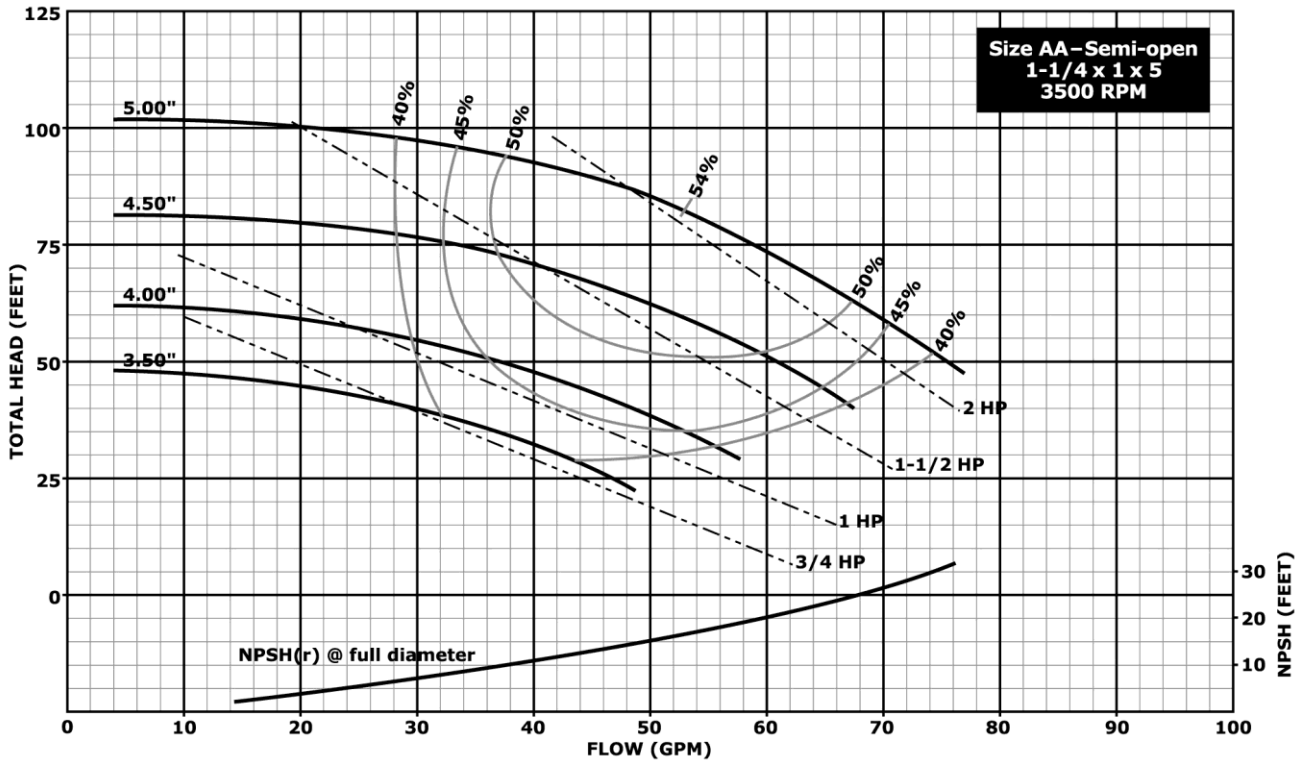

**Notes:**

1. Above data is based on 1.0 sp. gr. water at ambient temperature and pressure in accordance with Hydraulic Institute guidelines.
2. Impeller diameters between minimum and maximum shown are available in 1/8 inch increment trims.

**Hydraulic Performance – 5" Impeller Pumps**

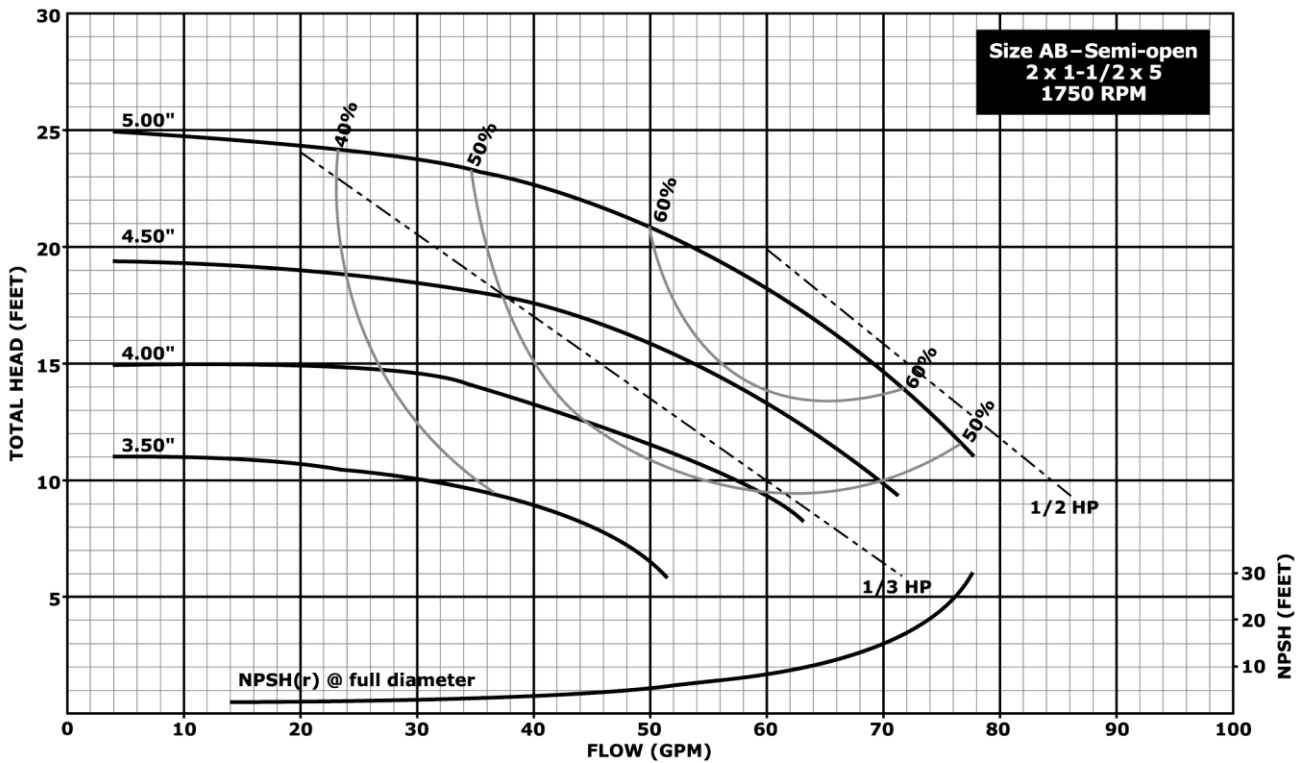
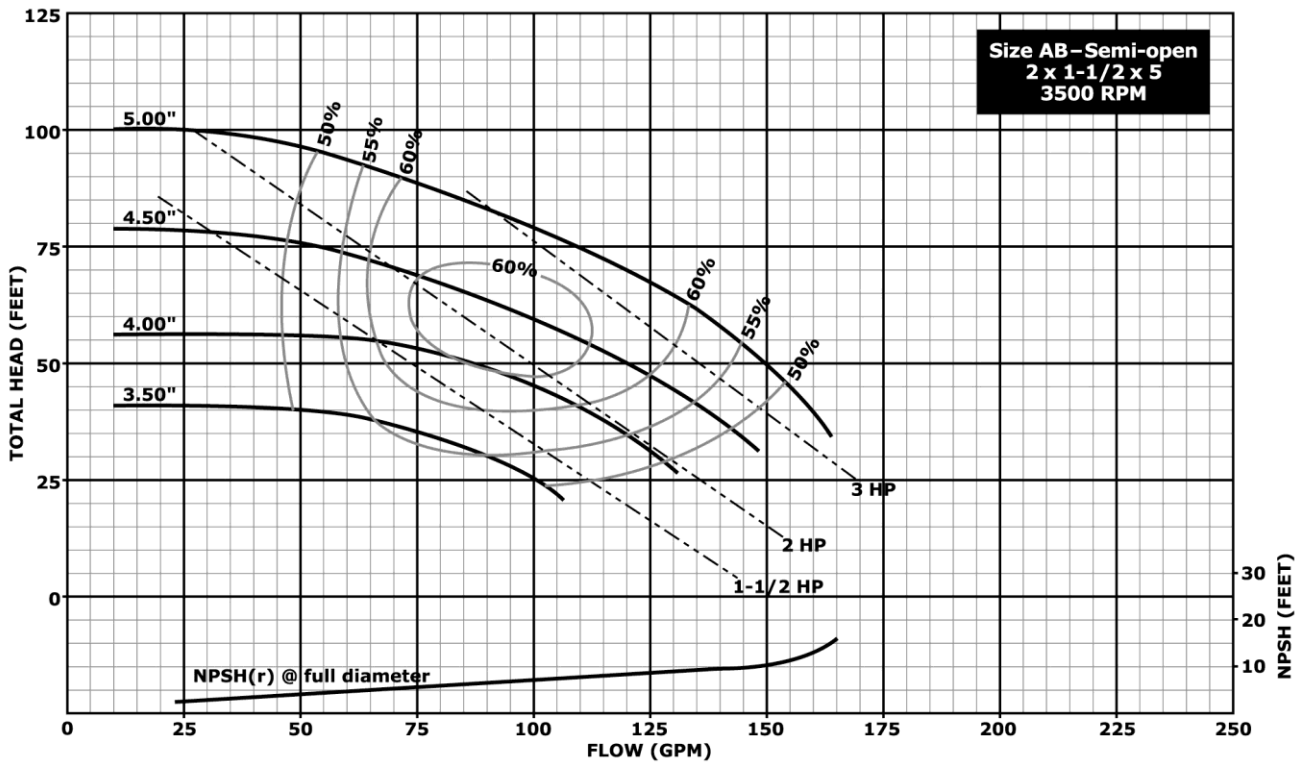

**Notes:**

1. Above data is based on 1.0 sp. gr. water at ambient temperature and pressure in accordance with Hydraulic Institute guidelines.
2. Impeller diameters between minimum and maximum shown are available in 1/8 inch increment trims.

Hydraulic Performance – 5” Impeller Pumps

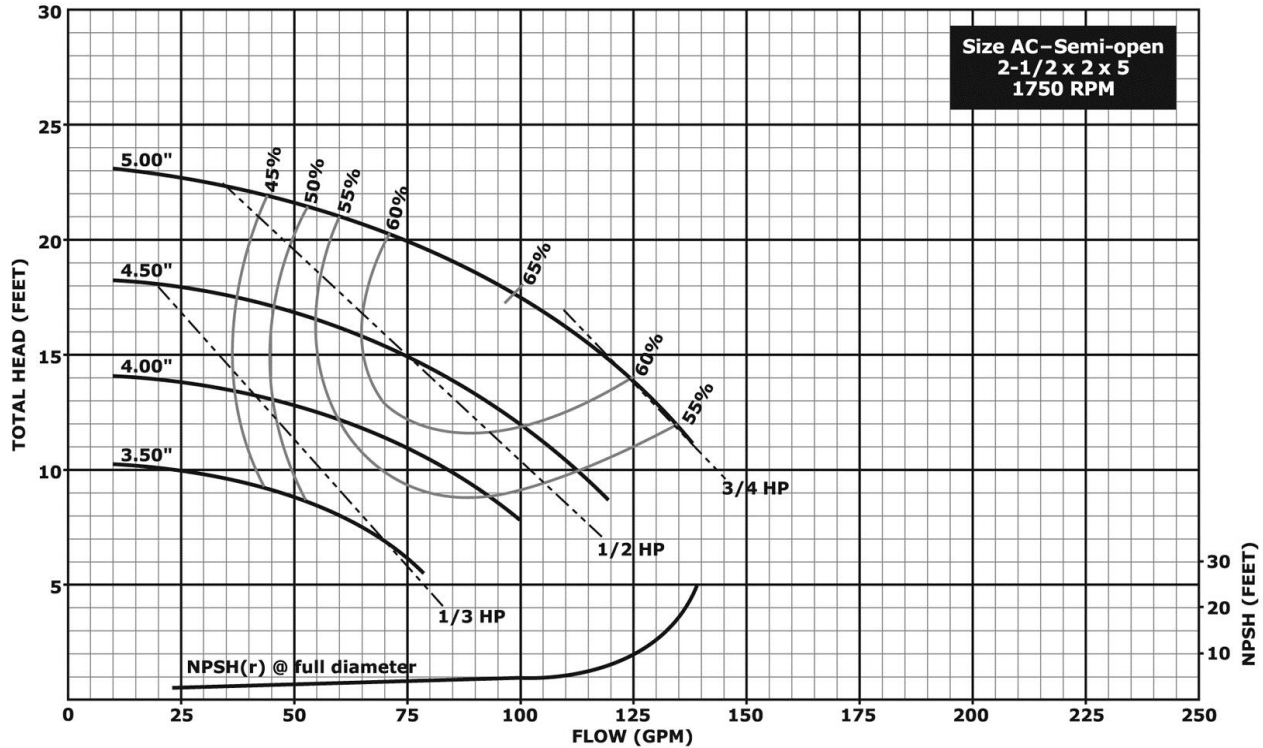
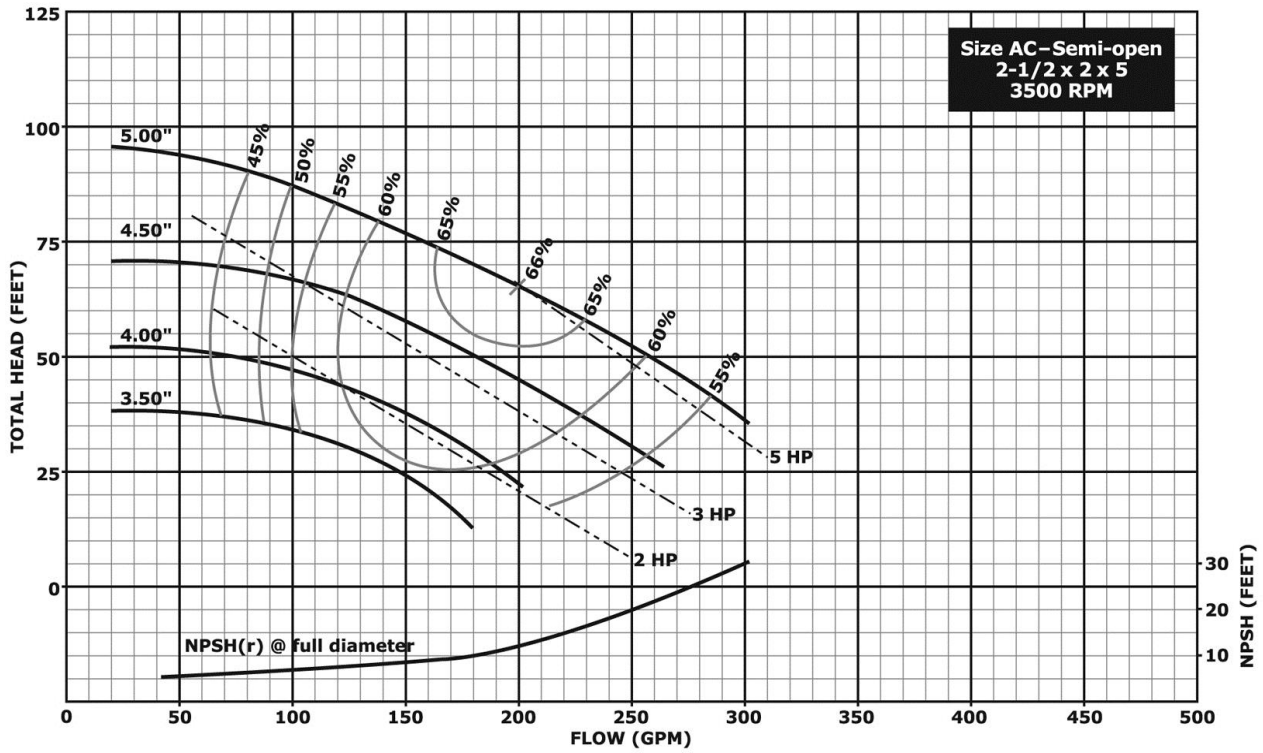

**Notes:**

1. Above data is based on 1.0 sp. gr. water at ambient temperature and pressure in accordance with Hydraulic Institute guidelines.
2. Impeller diameters between minimum and maximum shown are available in 1/8 inch increment trims.

### Hydraulic Performance – 7” Impeller Pumps

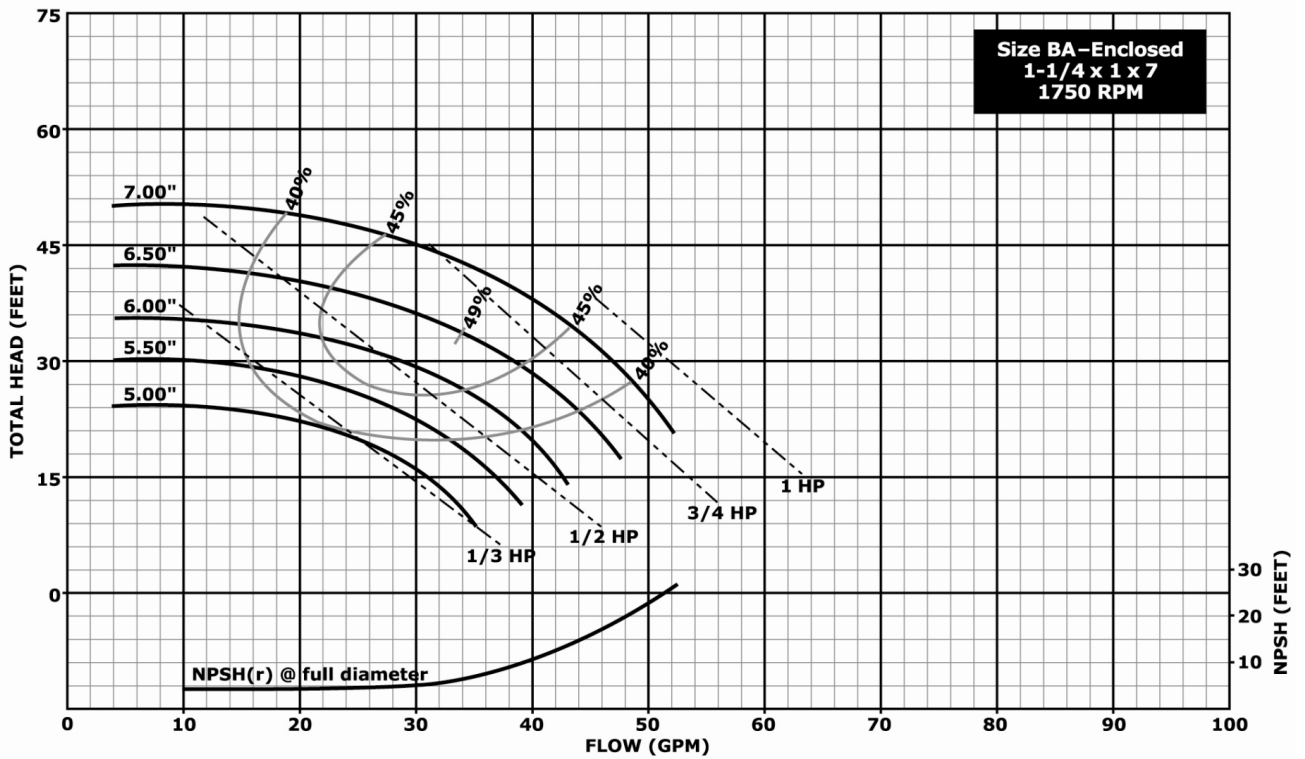
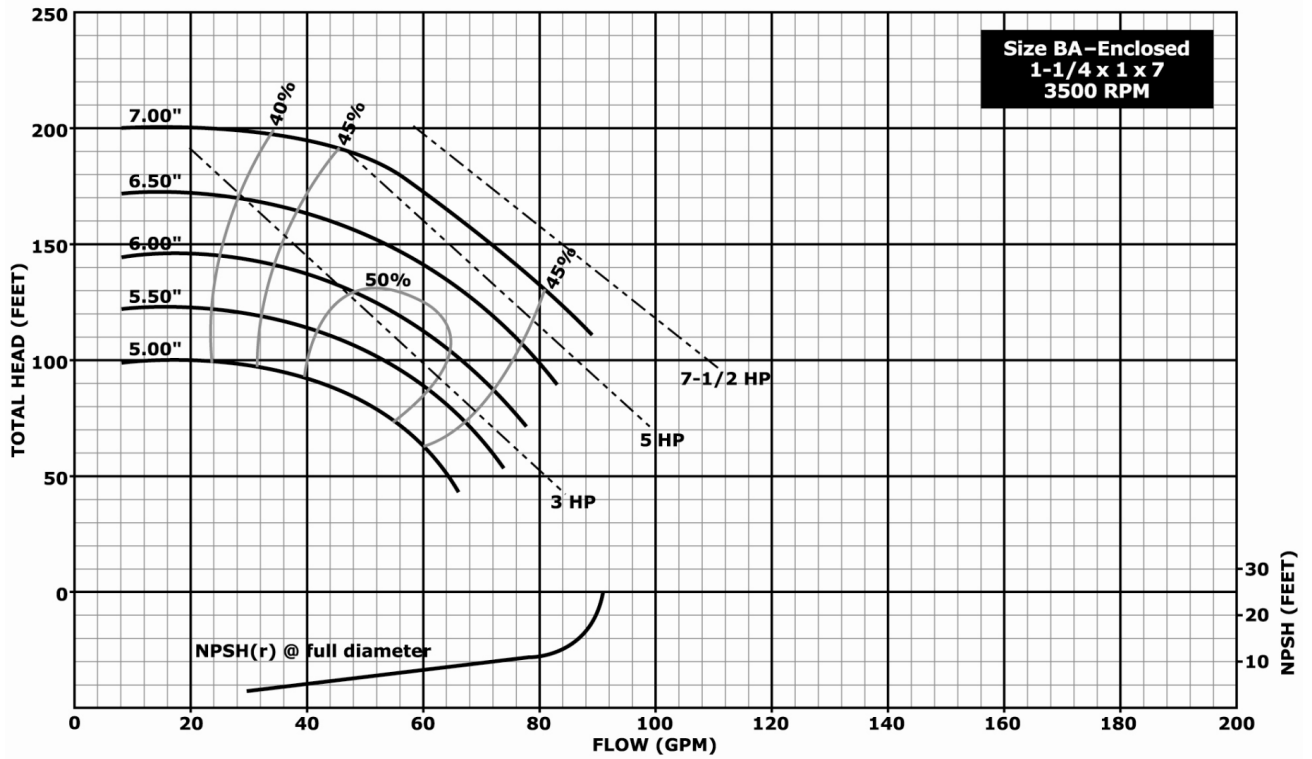

**Notes:**

1. Above data is based on 1.0 sp. gr. water at ambient temperature and pressure in accordance with Hydraulic Institute guidelines.
2. Impeller diameters between minimum and maximum shown are available in 1/8 inch increment trims.

**Hydraulic Performance – 7” Impeller Pumps**

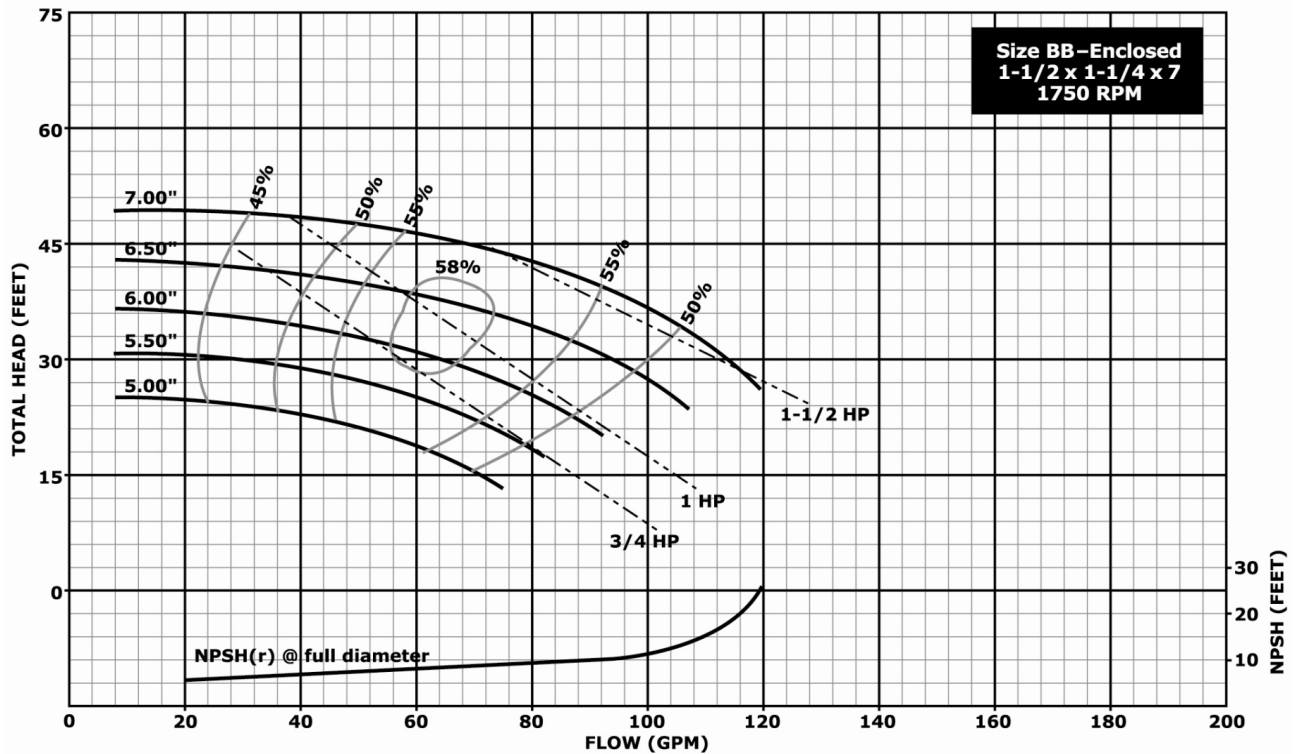
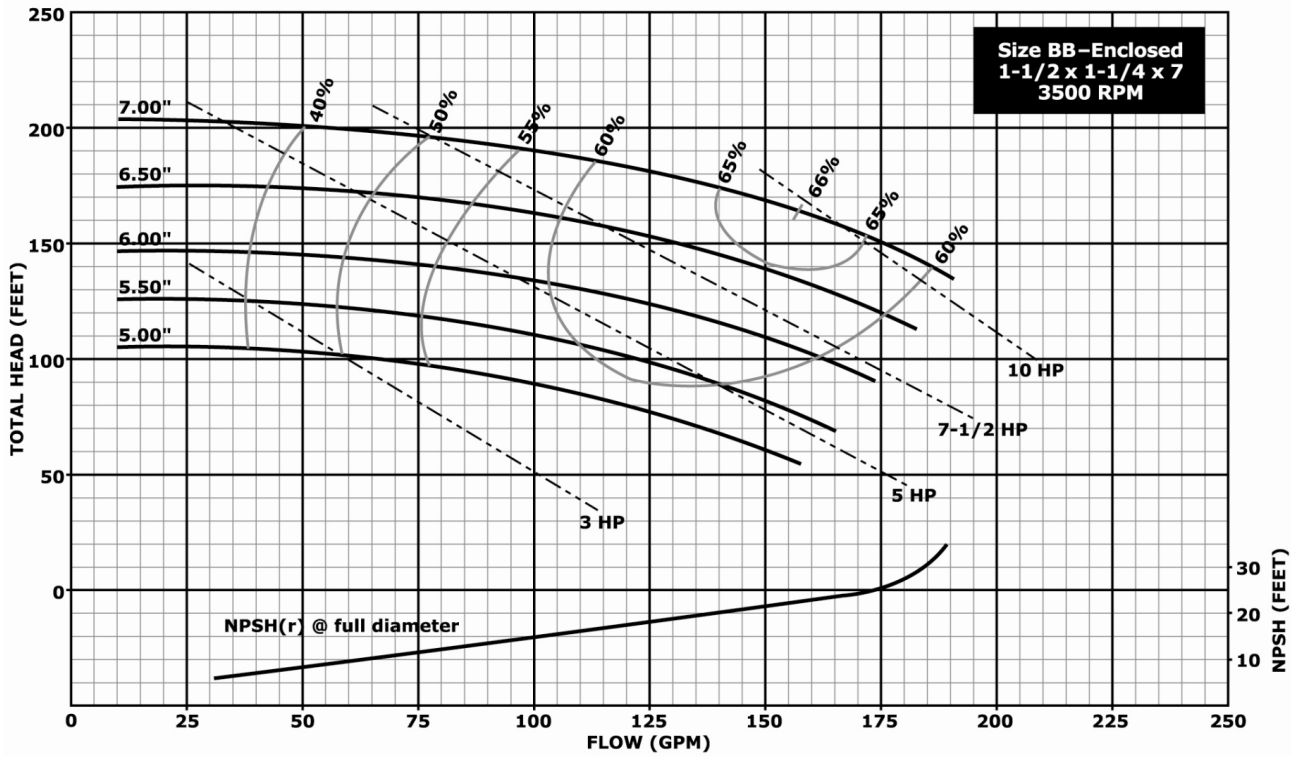

**Notes:**

1. Above data is based on 1.0 sp. gr. water at ambient temperature and pressure in accordance with Hydraulic Institute guidelines.
2. Impeller diameters between minimum and maximum shown are available in 1/8 inch increment trims.

**Hydraulic Performance – 7” Impeller Pumps**

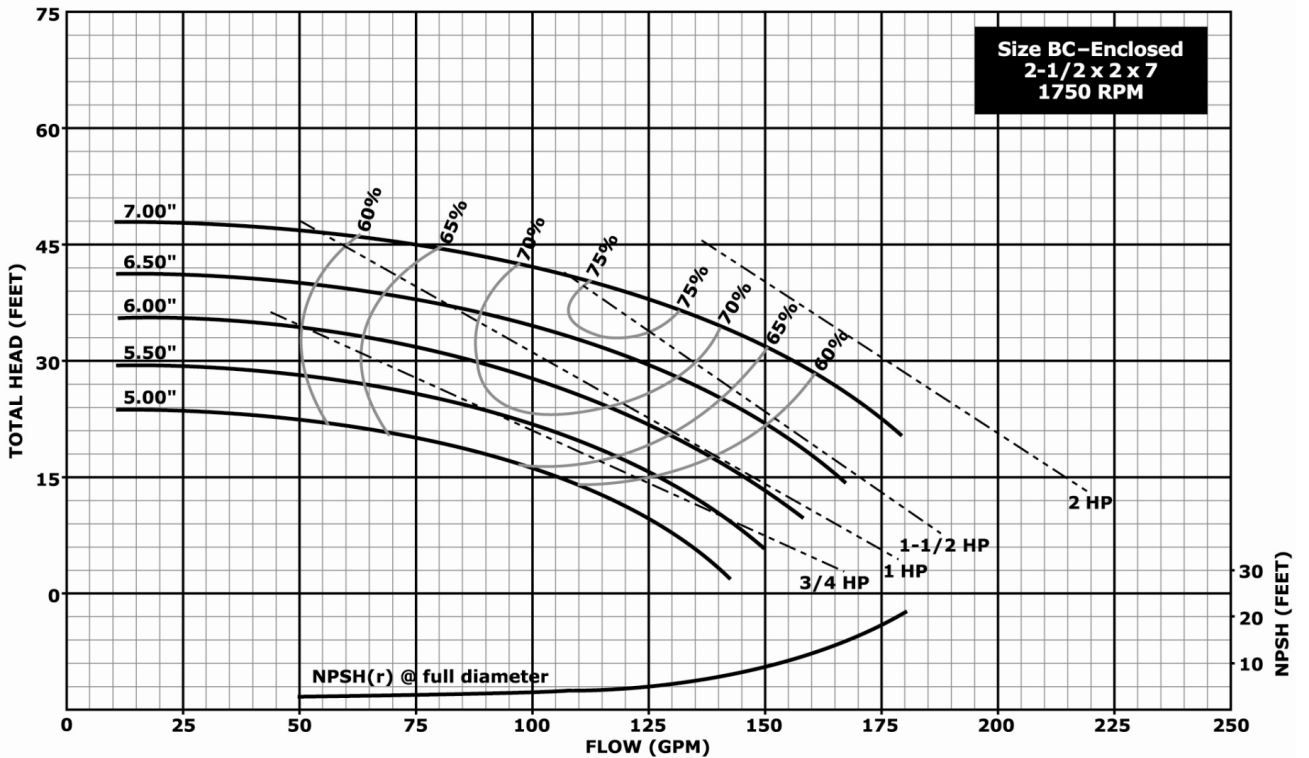
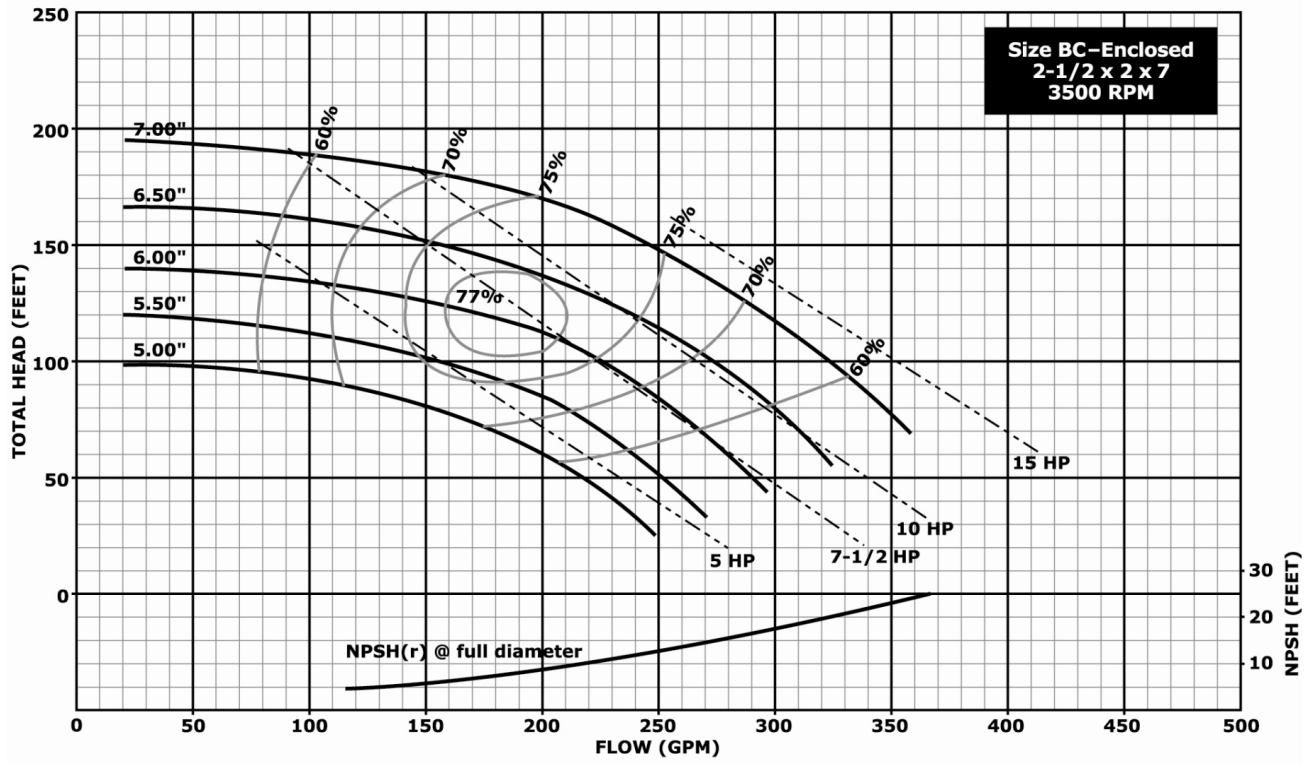

**Notes:**

1. Above data is based on 1.0 sp. gr. water at ambient temperature and pressure in accordance with Hydraulic Institute guidelines.
2. Impeller diameters between minimum and maximum shown are available in 1/8 inch increment trims.

### Hydraulic Performance – 7” Impeller Pumps

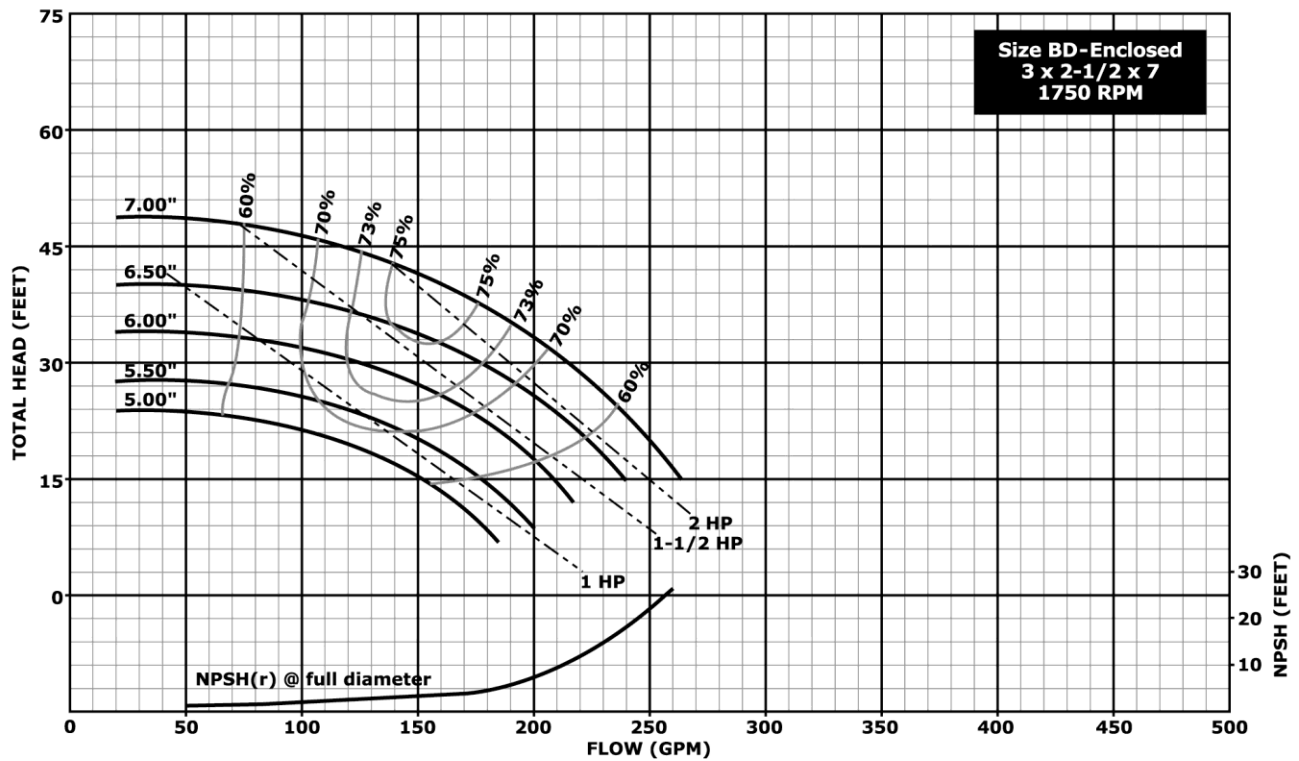
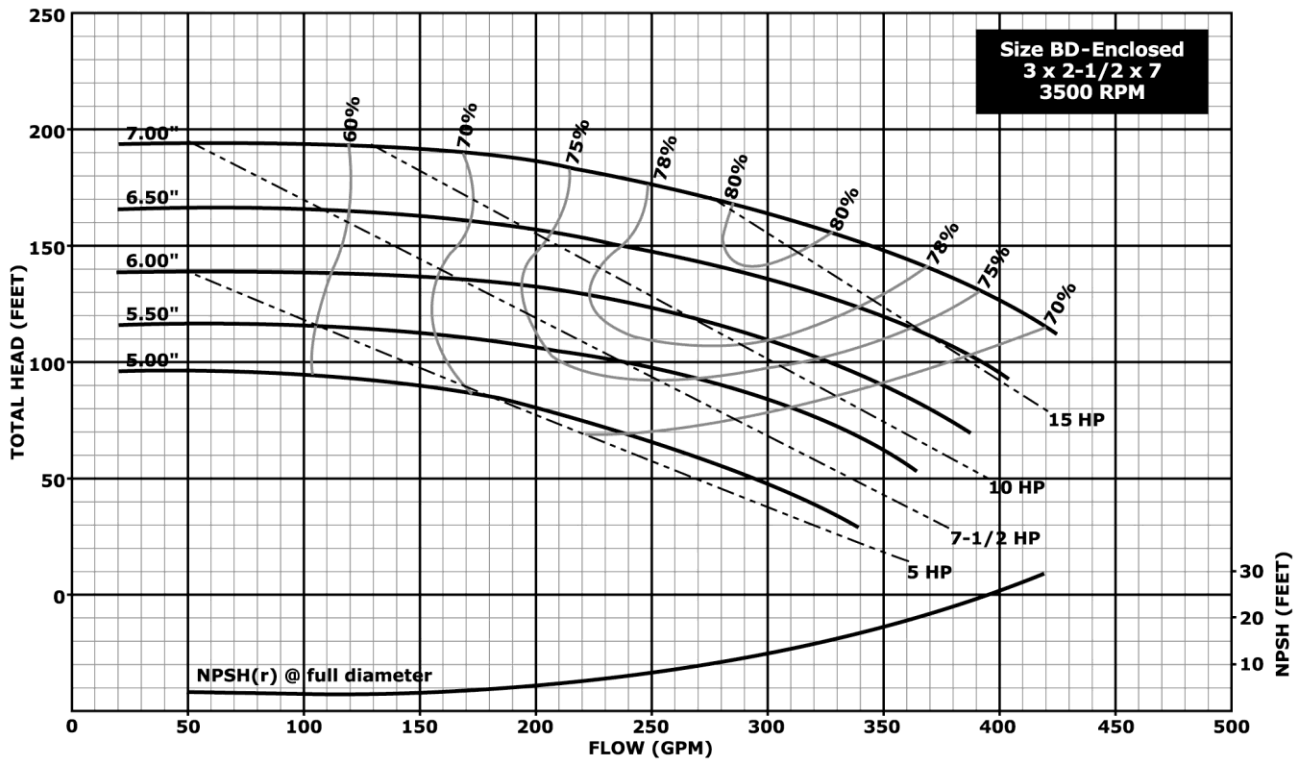

**Notes:**

1. Above data is based on 1.0 sp. gr. water at ambient temperature and pressure in accordance with Hydraulic Institute guidelines.
2. Impeller diameters between minimum and maximum shown are available in 1/8 inch increment trims.

Hydraulic Performance – 7" Impeller Pumps

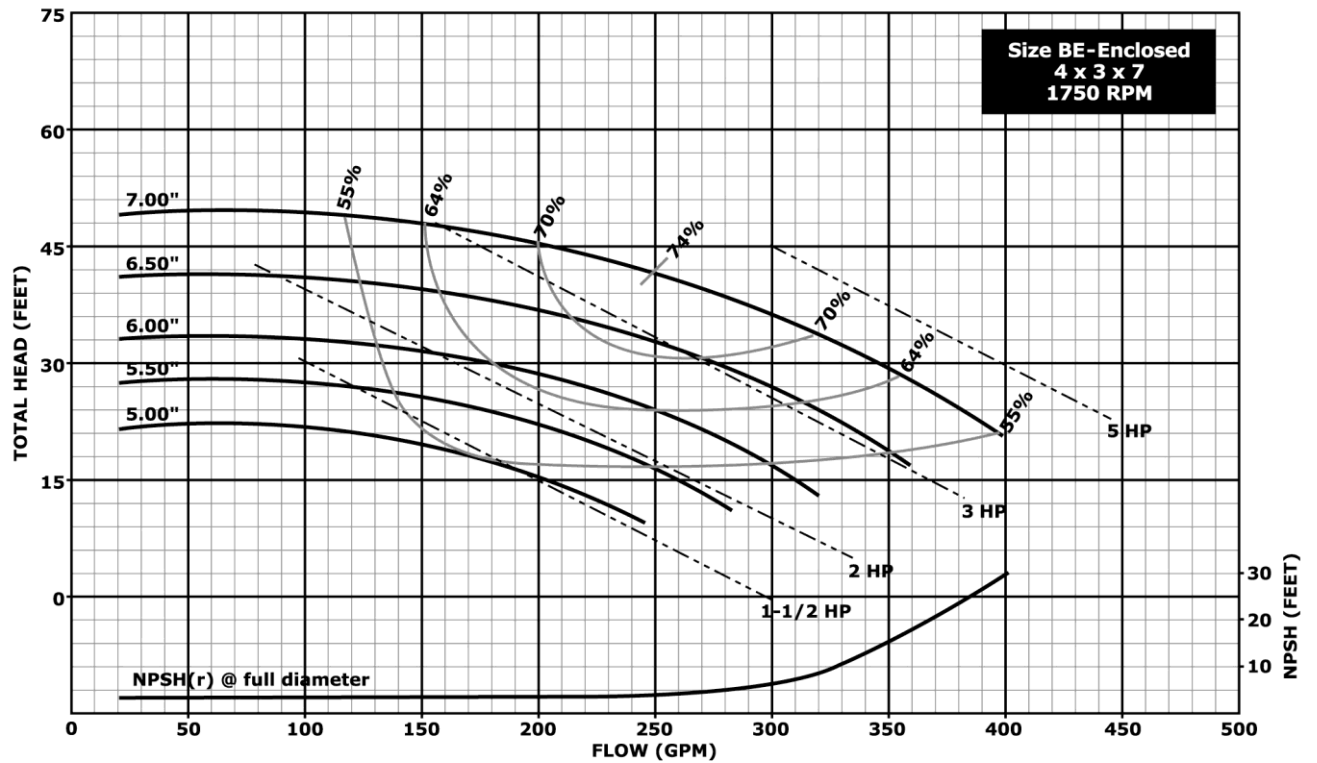
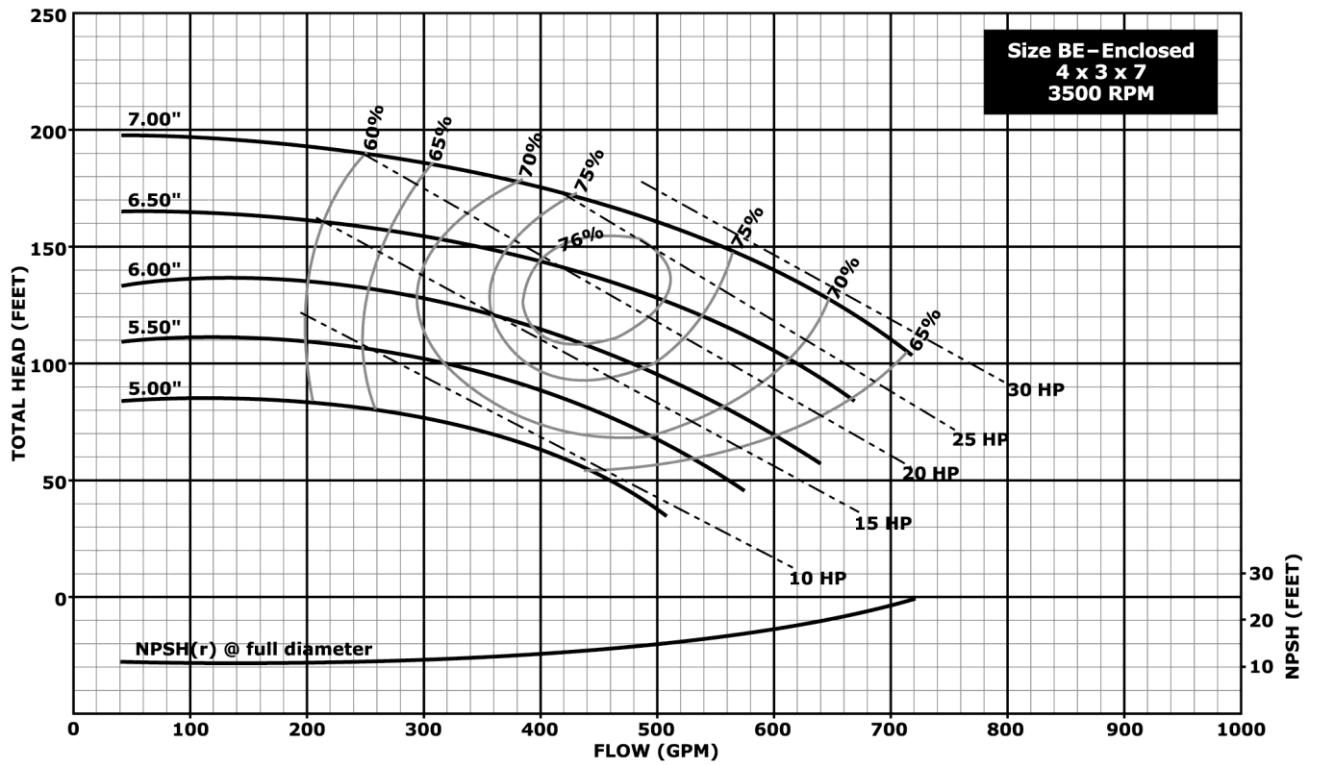

**Notes:**

1. Above data is based on 1.0 sp. gr. water at ambient temperature and pressure in accordance with Hydraulic Institute guidelines.
2. Impeller diameters between minimum and maximum shown are available in 1/8 inch increment trims.

**Hydraulic Performance – 7” Impeller Pumps**

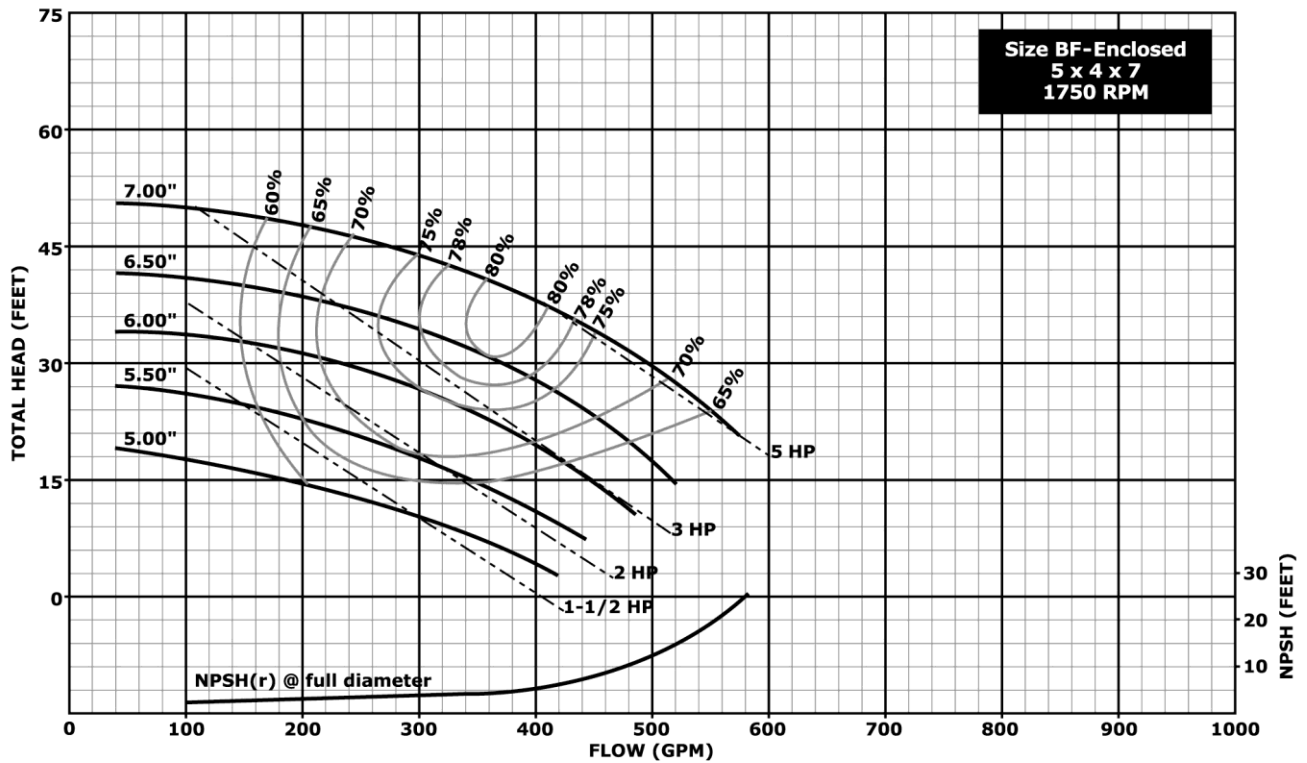
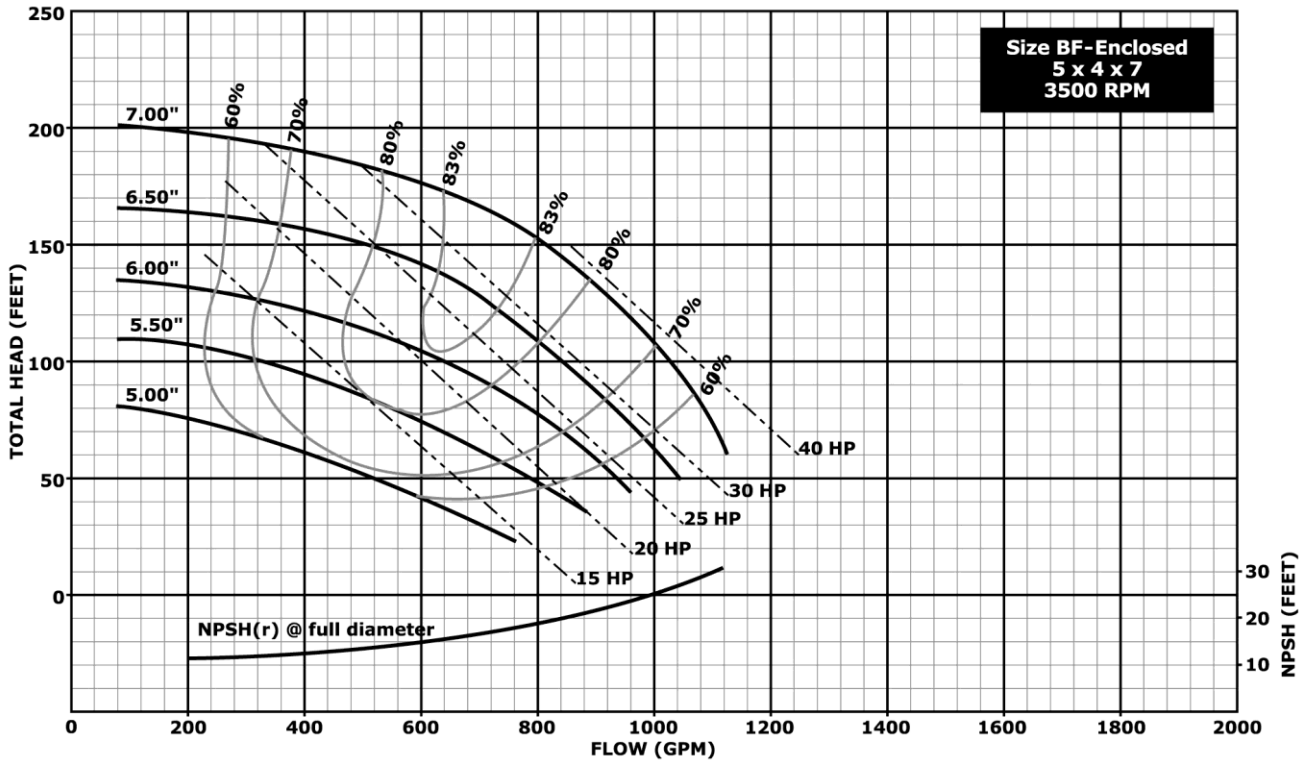

**Notes:**

1. Above data is based on 1.0 sp. gr. water at ambient temperature and pressure in accordance with Hydraulic Institute guidelines.
2. Impeller diameters between minimum and maximum shown are available in 1/8 inch increment trims.

**Hydraulic Performance – 10” Impeller Pumps**

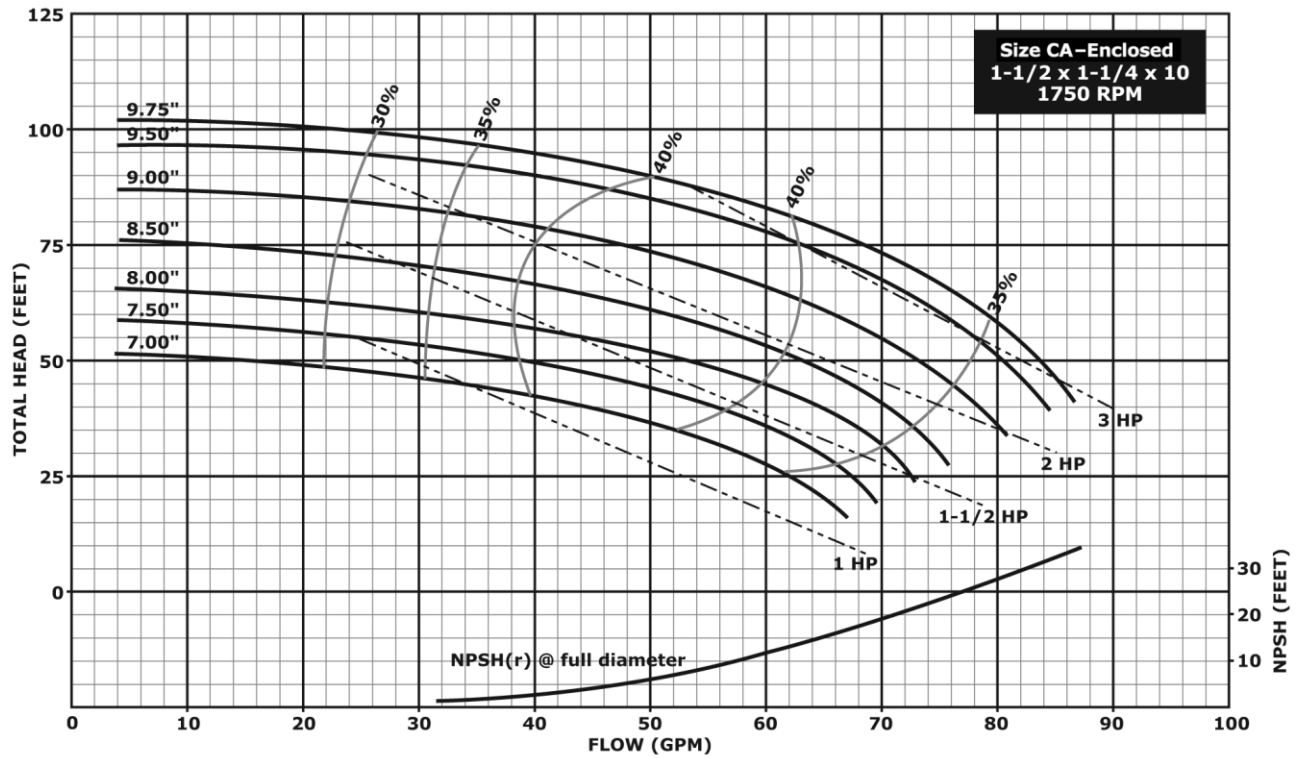
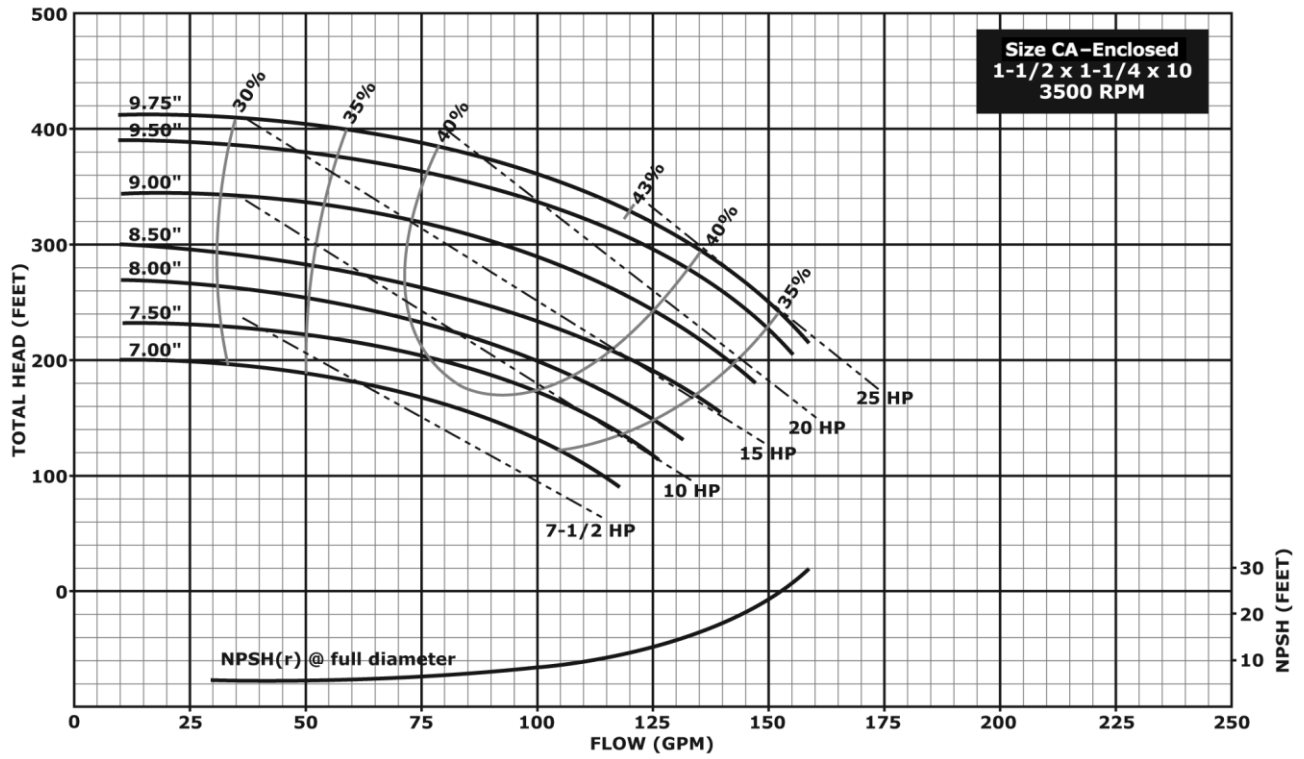

**Notes:**

1. Above data is based on 1.0 sp. gr. water at ambient temperature and pressure in accordance with Hydraulic Institute guidelines.
2. Impeller diameters between minimum and maximum shown are available in 1/8 inch increment trims.

Hydraulic Performance – 10” Impeller Pumps

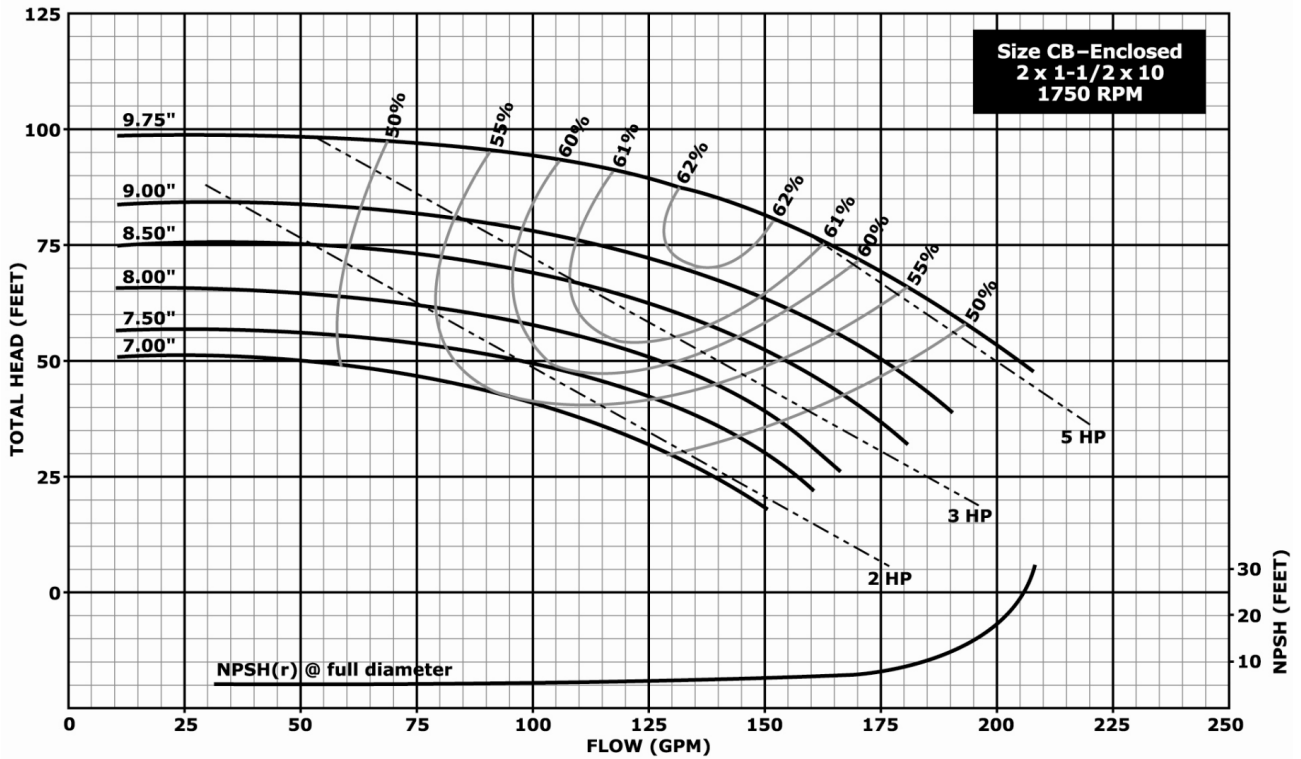
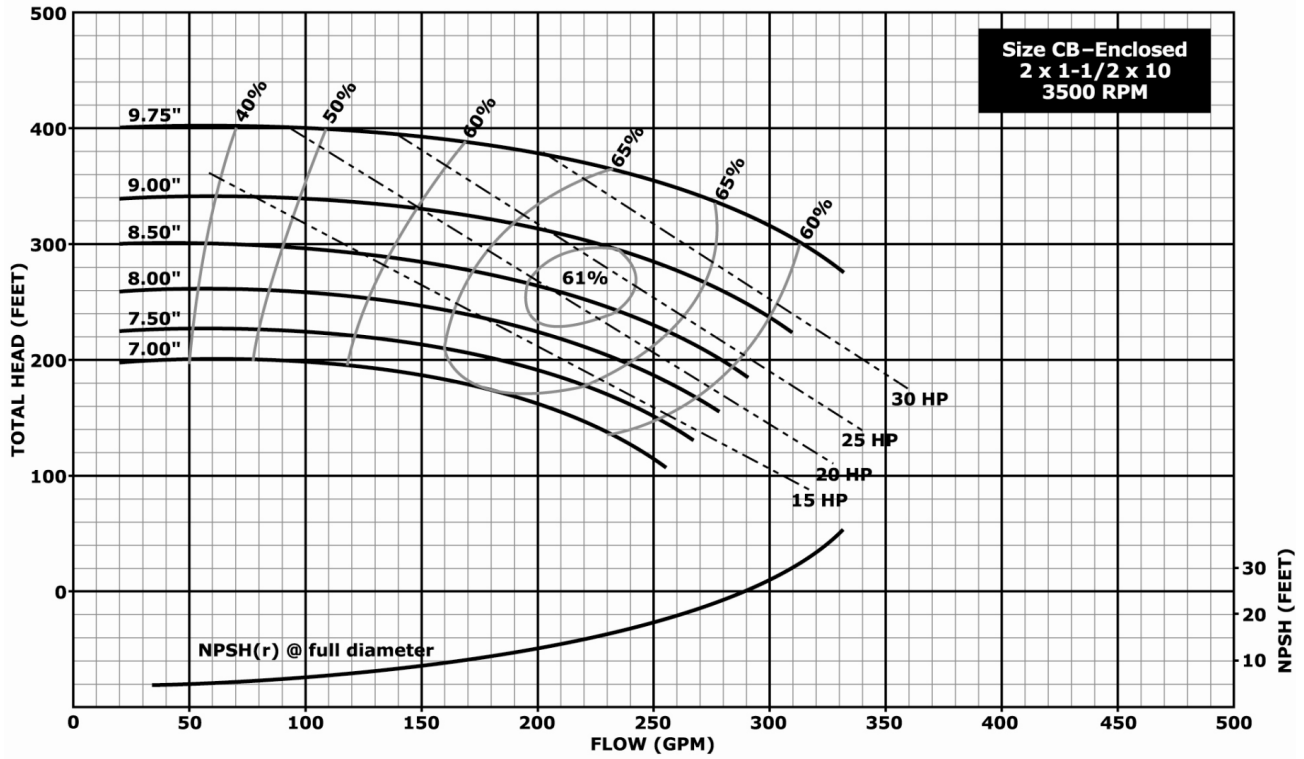

**Notes:**

1. Above data is based on 1.0 sp. gr. water at ambient temperature and pressure in accordance with Hydraulic Institute guidelines.
2. Impeller diameters between minimum and maximum shown are available in 1/8 inch increment trims.

Hydraulic Performance – 10” Impeller Pumps

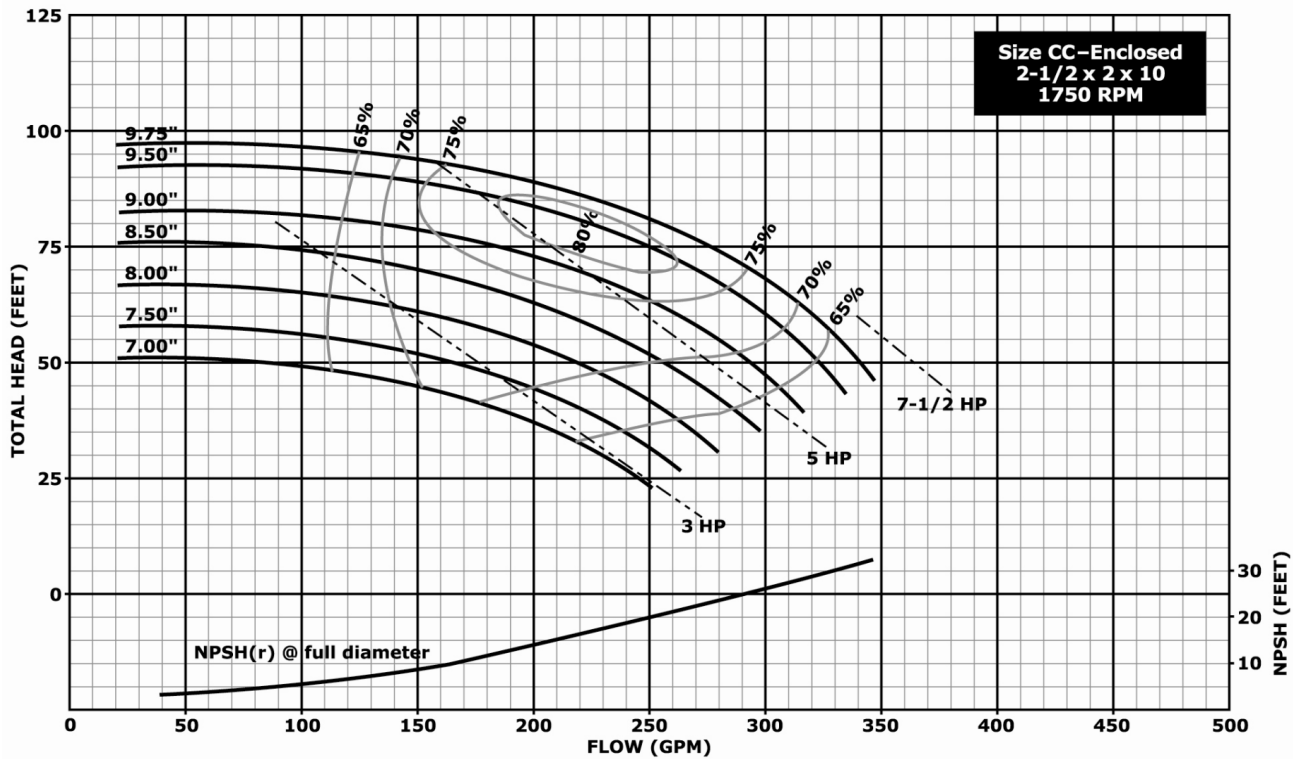
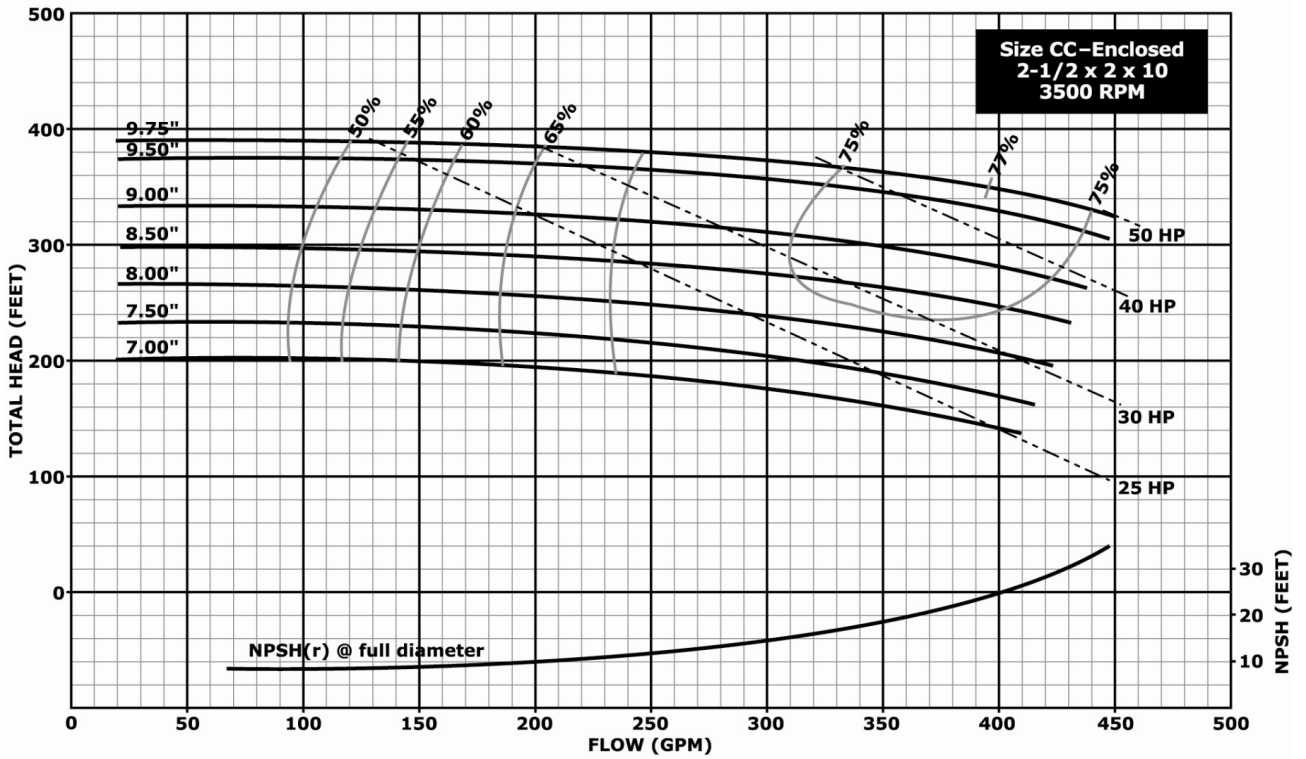

**Notes:**

1. Above data is based on 1.0 sp. gr. water at ambient temperature and pressure in accordance with Hydraulic Institute guidelines.
2. Impeller diameters between minimum and maximum shown are available in 1/8 inch increment trims.

**Hydraulic Performance – 10" Impeller Pumps**

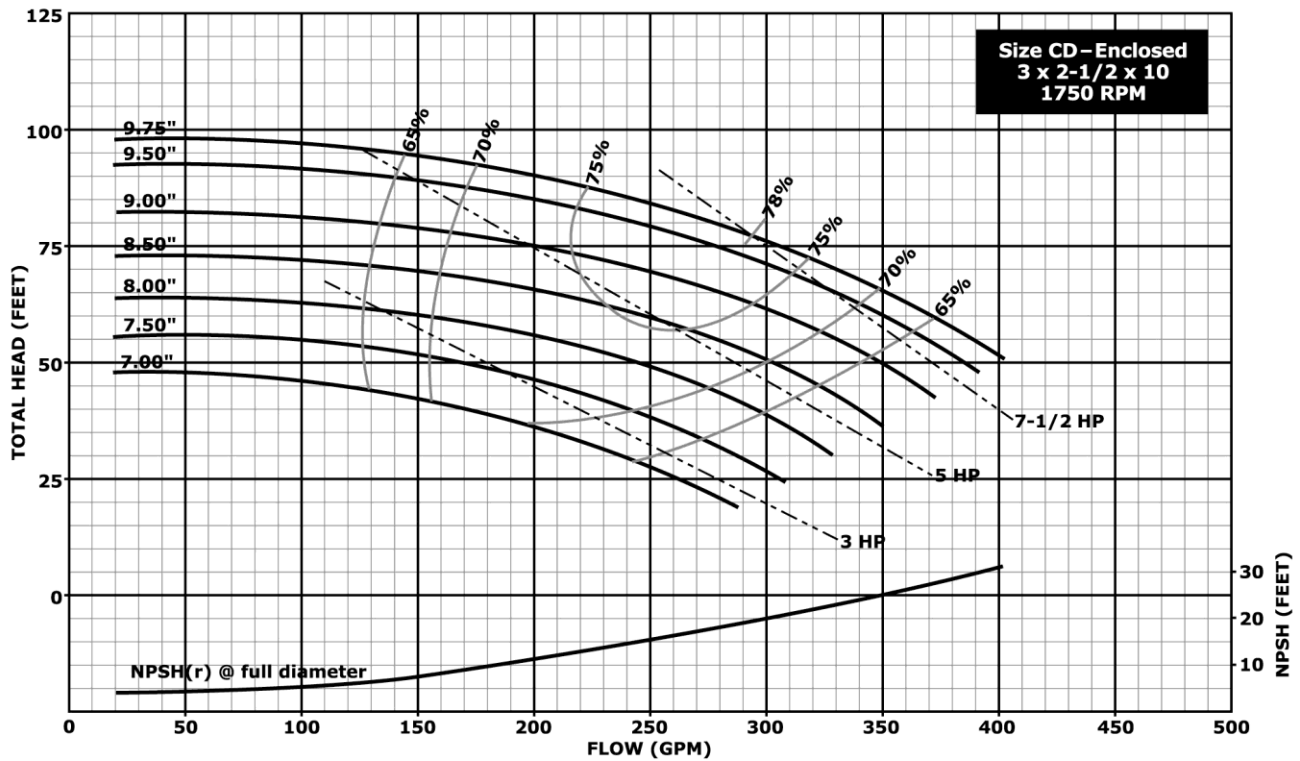
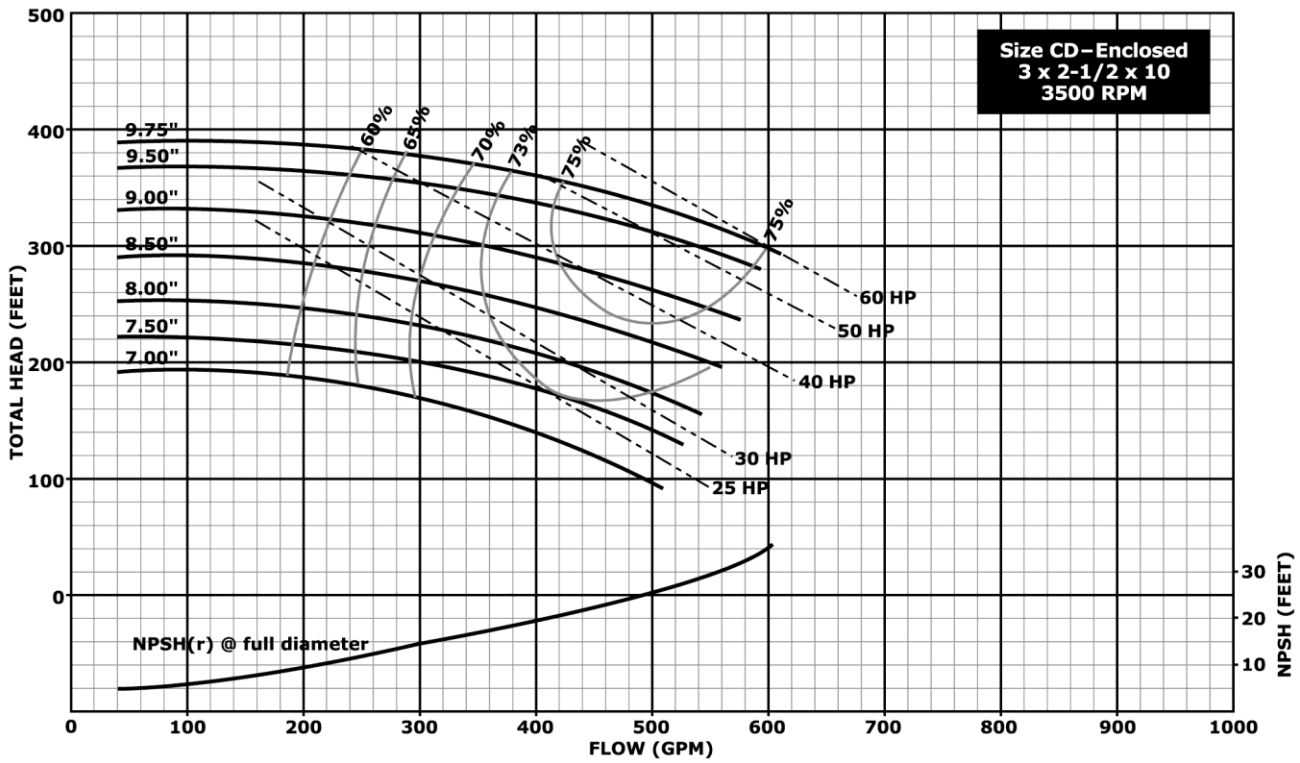

**Notes:**

1. Above data is based on 1.0 sp. gr. water at ambient temperature and pressure in accordance with Hydraulic Institute guidelines.
2. Impeller diameters between minimum and maximum shown are available in 1/8 inch increment trims.

Hydraulic Performance – 10” Impeller Pumps

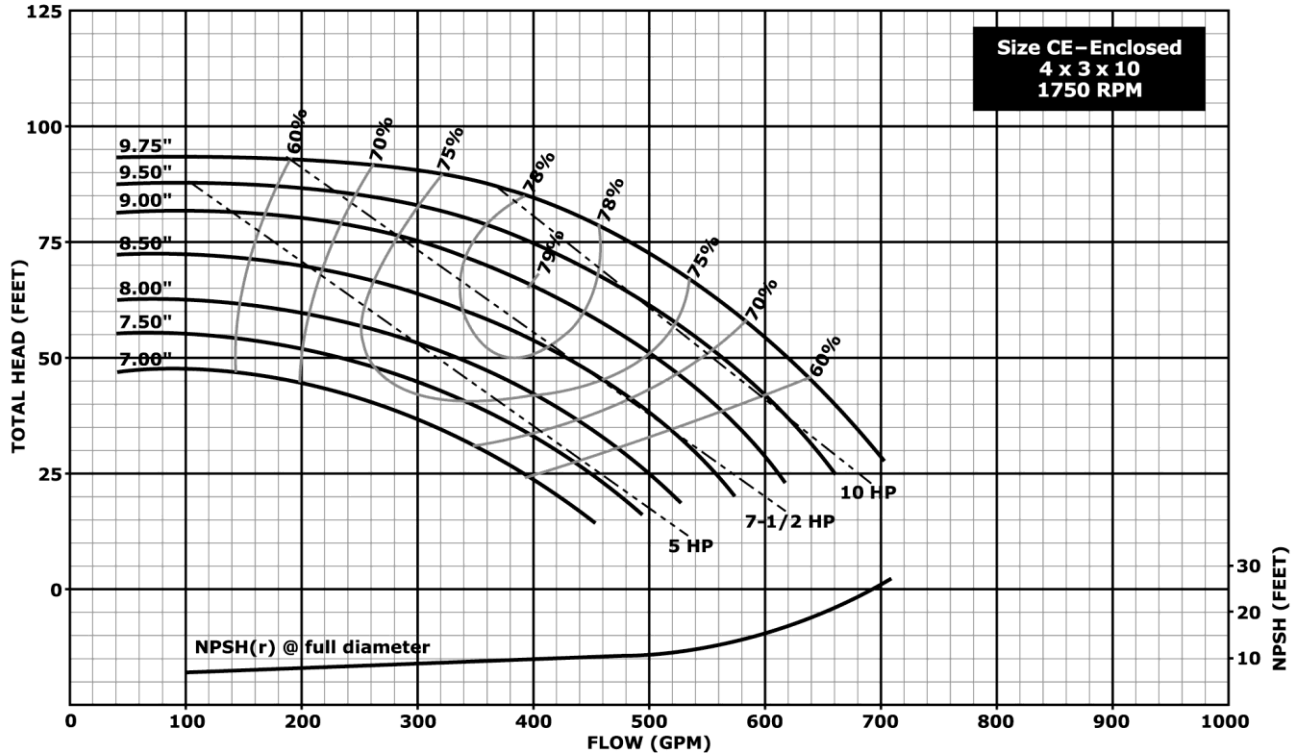
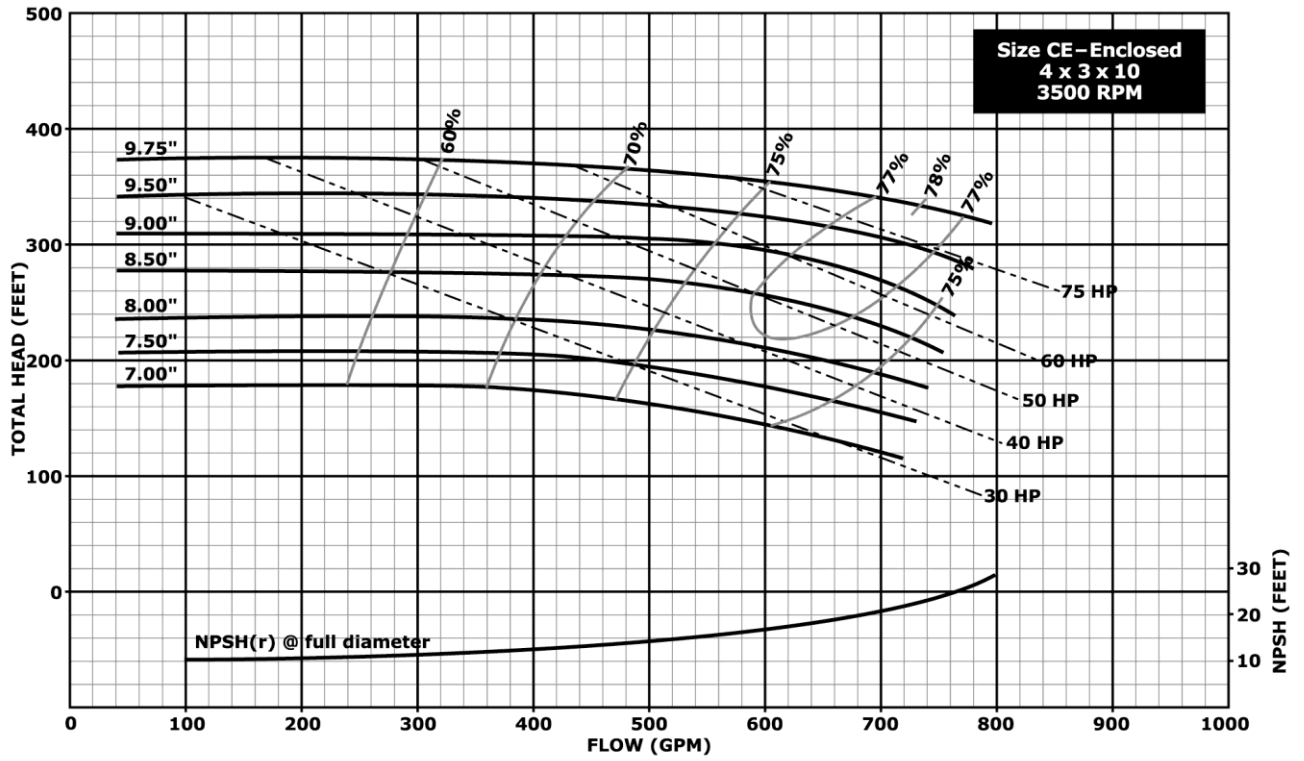

**Notes:**

1. Above data is based on 1.0 sp. gr. water at ambient temperature and pressure in accordance with Hydraulic Institute guidelines.
2. Impeller diameters between minimum and maximum shown are available in 1/8 inch increment trims.

### Hydraulic Performance – 10" Impeller Pumps

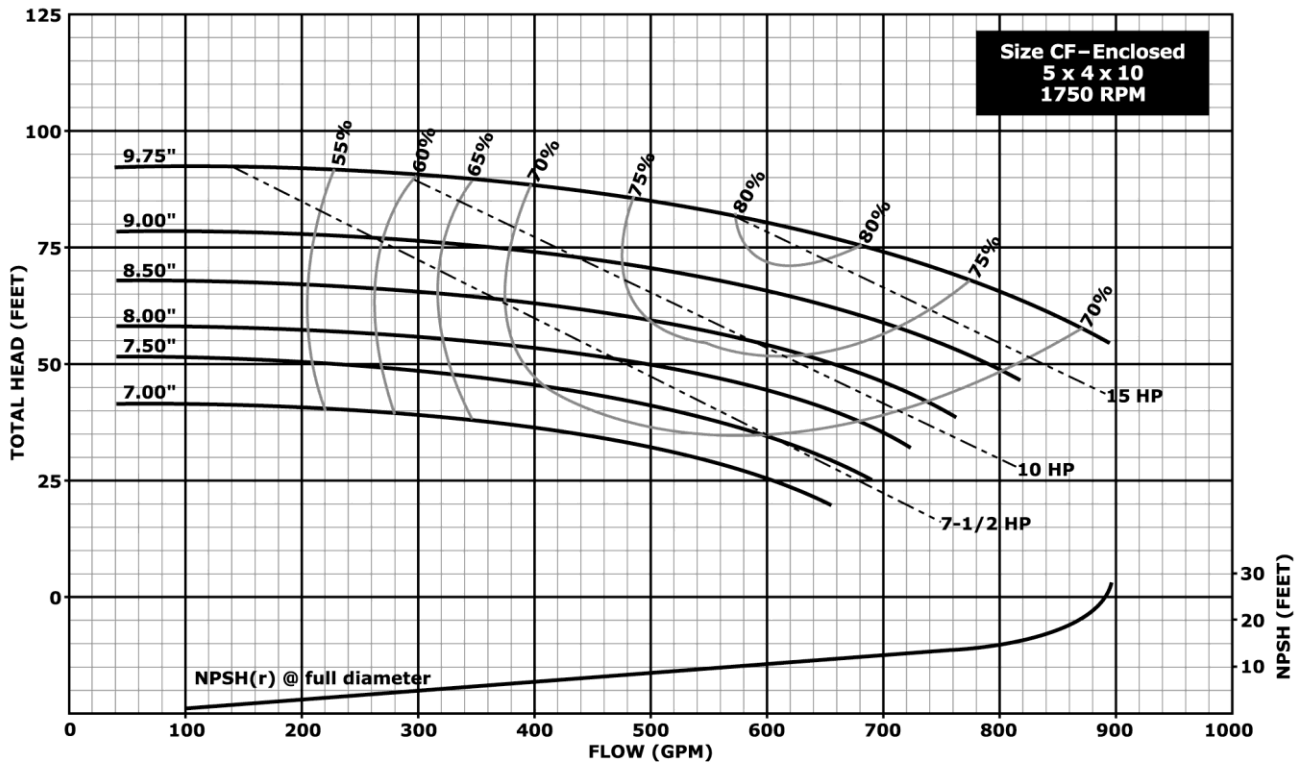
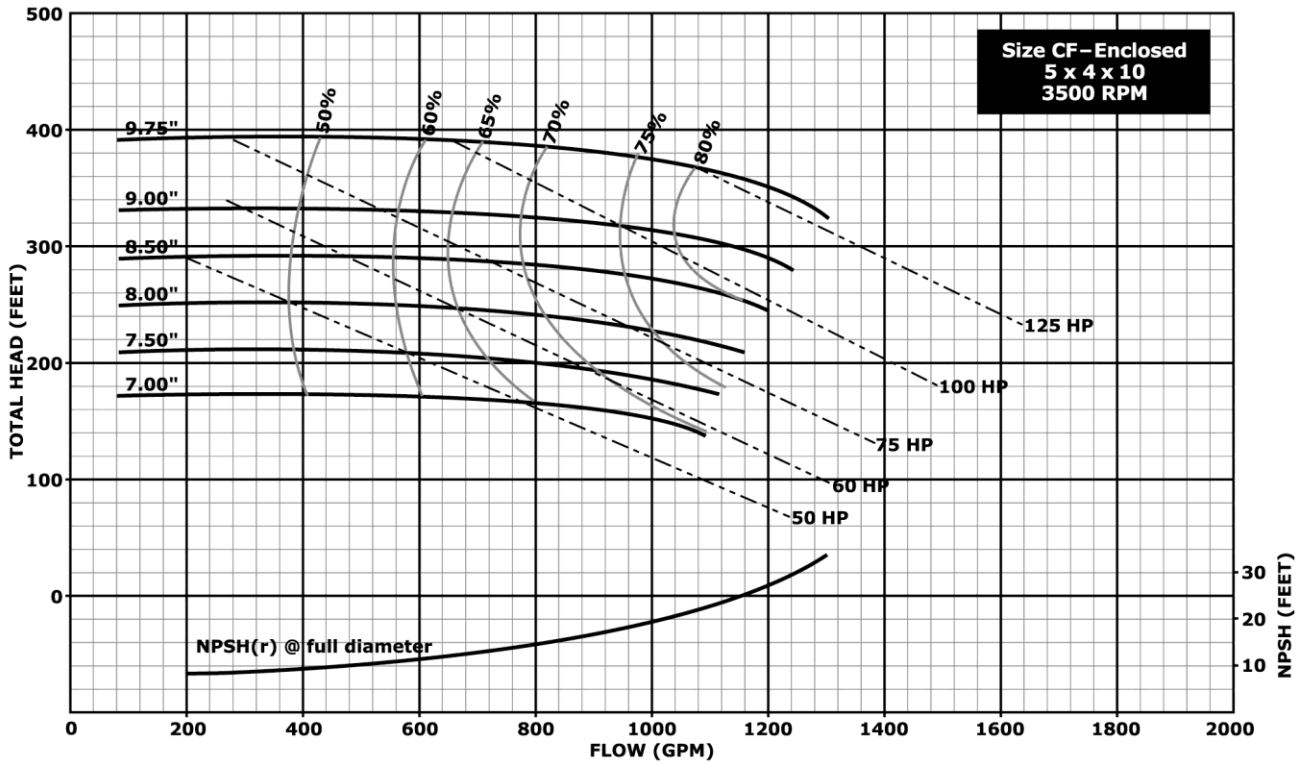

**Notes:**

1. Above data is based on 1.0 sp. gr. water at ambient temperature and pressure in accordance with Hydraulic Institute guidelines.
2. Impeller diameters between minimum and maximum shown are available in 1/8 inch increment trims.

Hydraulic Performance – 10” Impeller Pumps

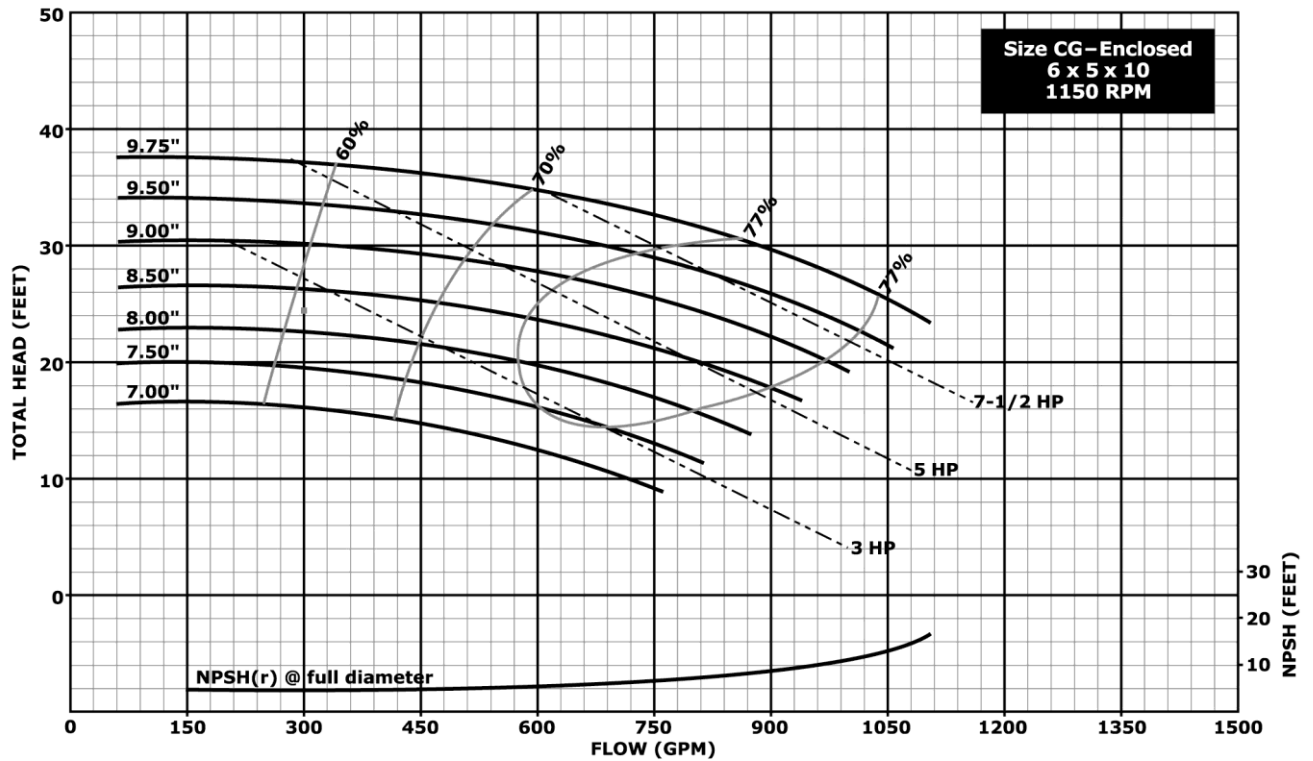
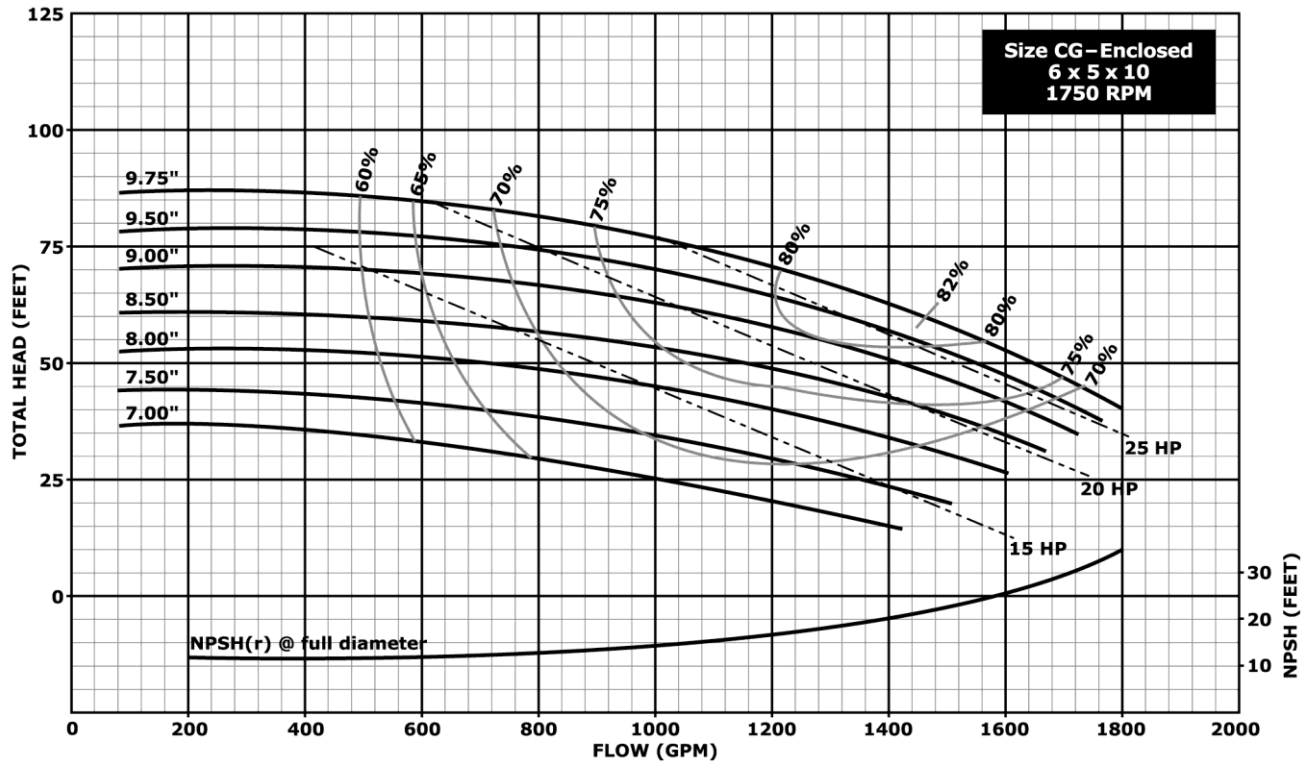

**Notes:**

1. Above data is based on 1.0 sp. gr. water at ambient temperature and pressure in accordance with Hydraulic Institute guidelines.
2. Impeller diameters between minimum and maximum shown are available in 1/8 inch increment trims.

### Hydraulic Performance – 11" Impeller Pumps

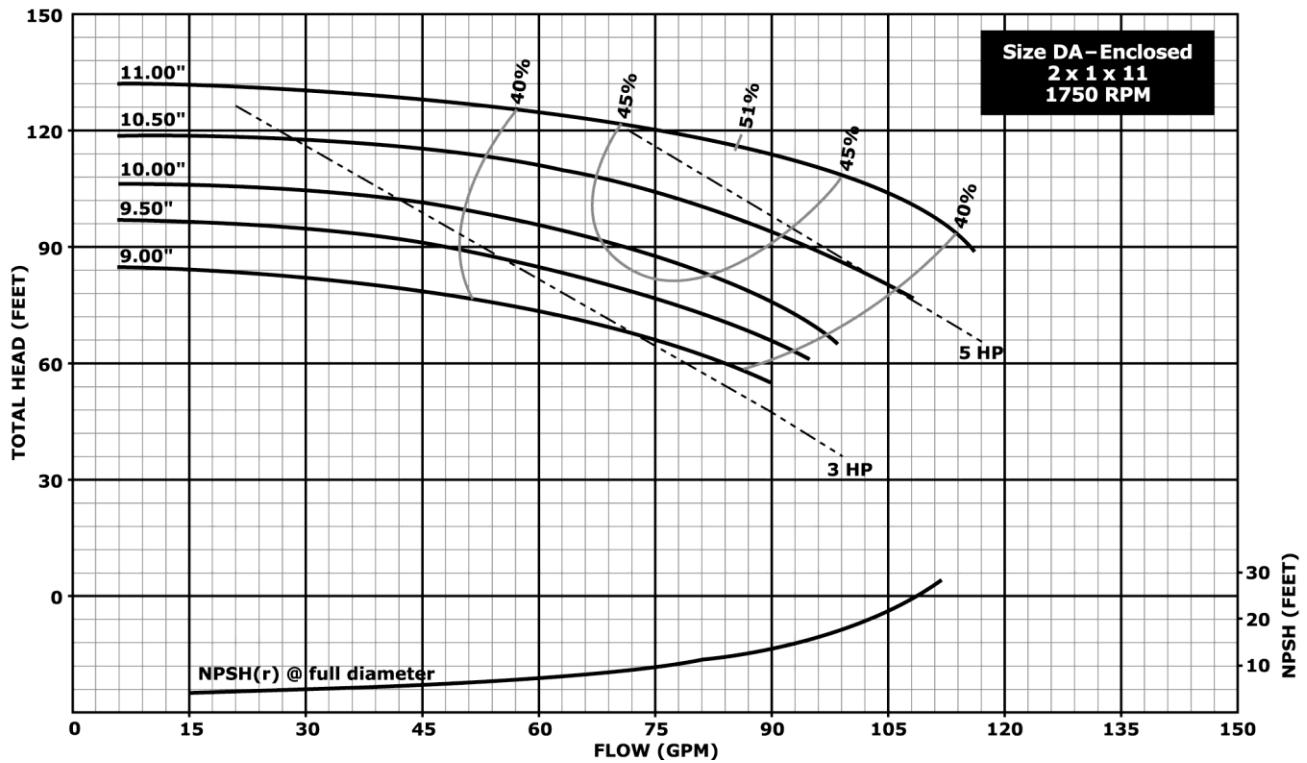
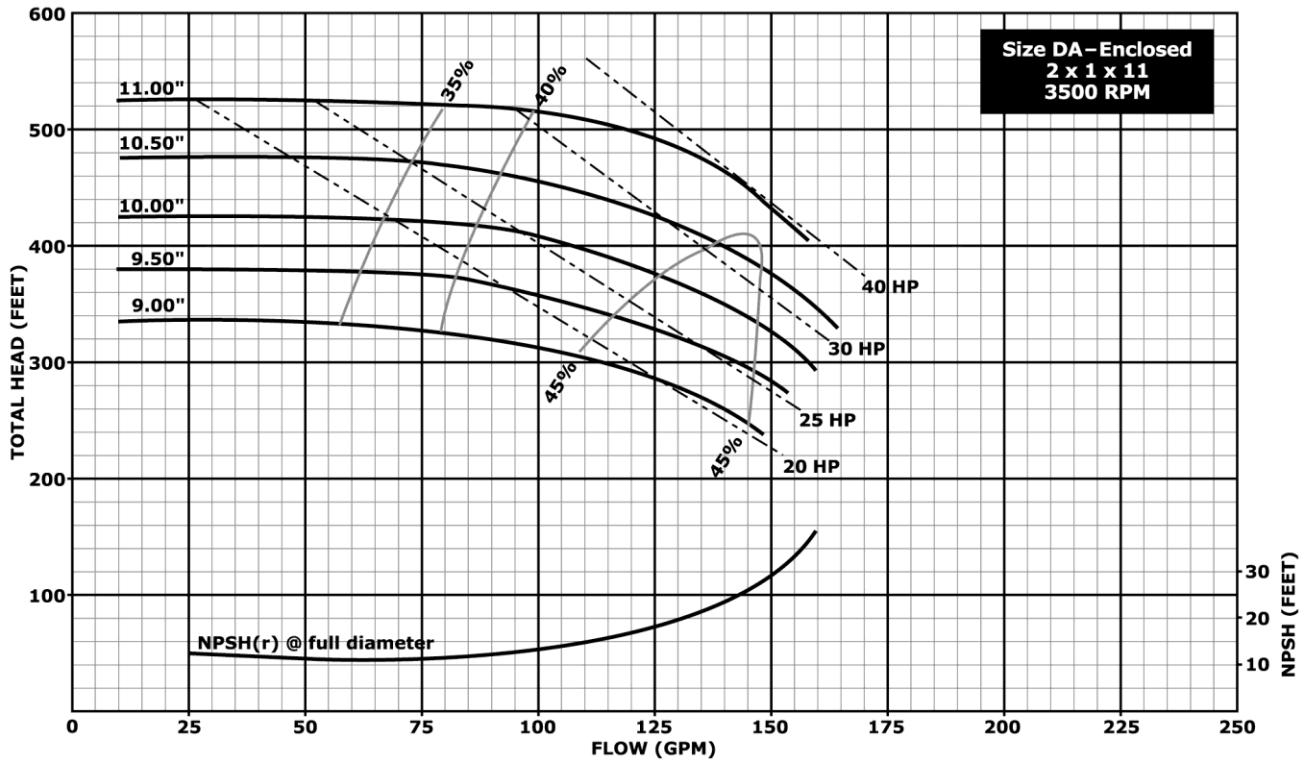

**Notes:**

1. Above data is based on 1.0 sp. gr. water at ambient temperature and pressure in accordance with Hydraulic Institute guidelines.
2. Impeller diameters between minimum and maximum shown are available in 1/8 inch increment trims.

Hydraulic Performance – 11” Impeller Pumps

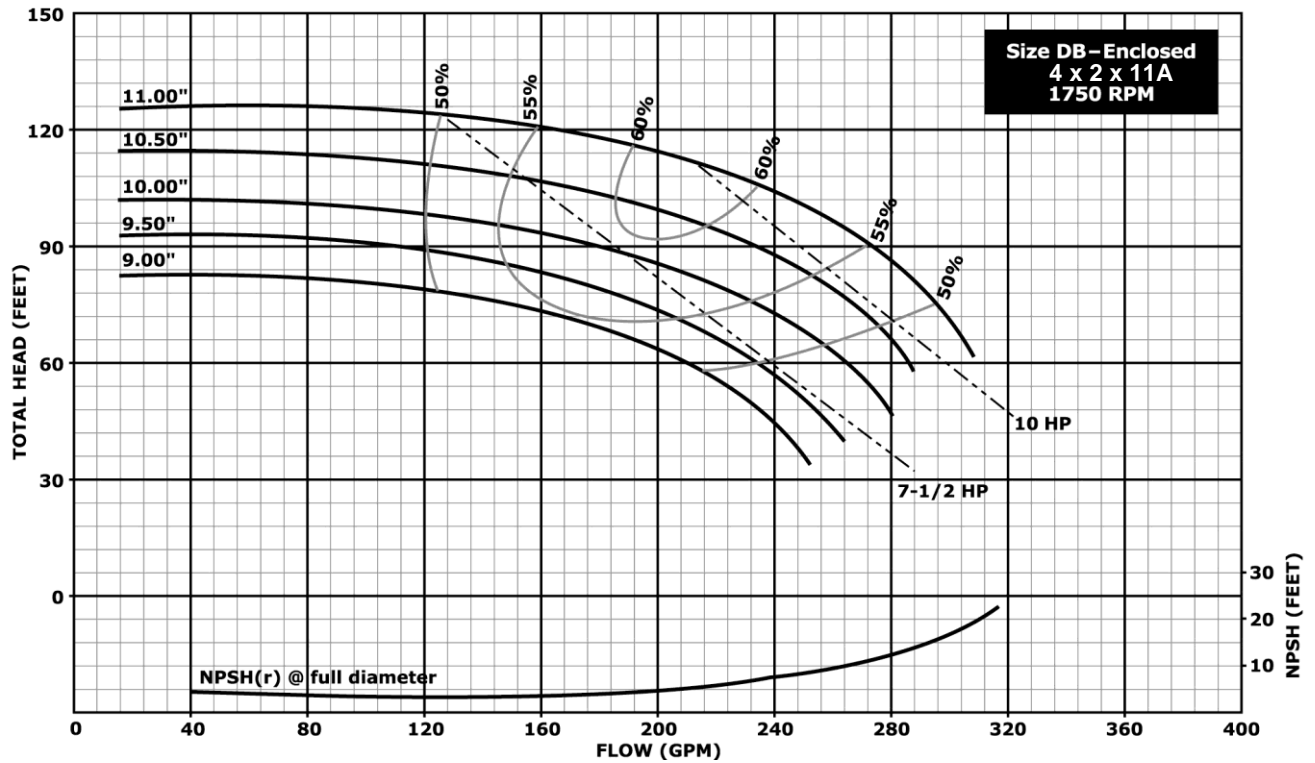
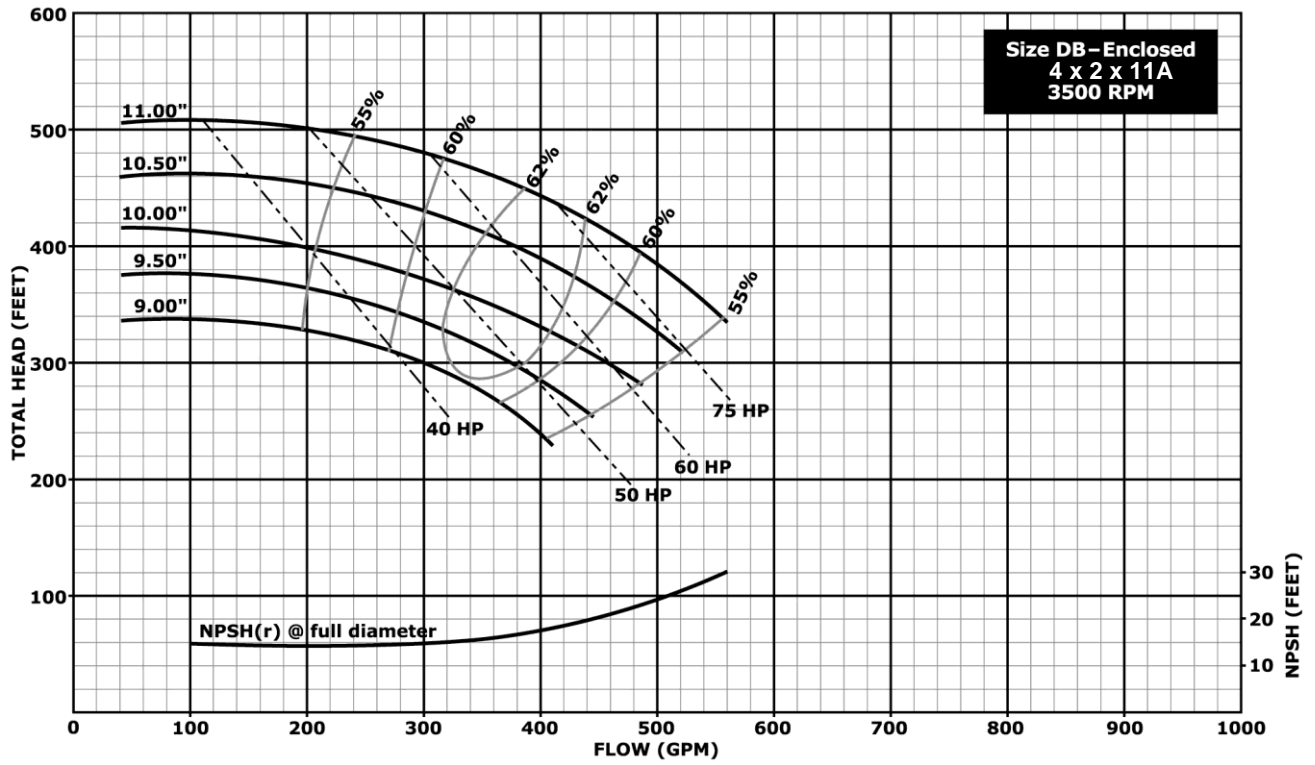

**Notes:**

1. Above data is based on 1.0 sp. gr. water at ambient temperature and pressure in accordance with Hydraulic Institute guidelines.
2. Impeller diameters between minimum and maximum shown are available in 1/8 inch increment trims.

### Hydraulic Performance – 11” Impeller Pumps

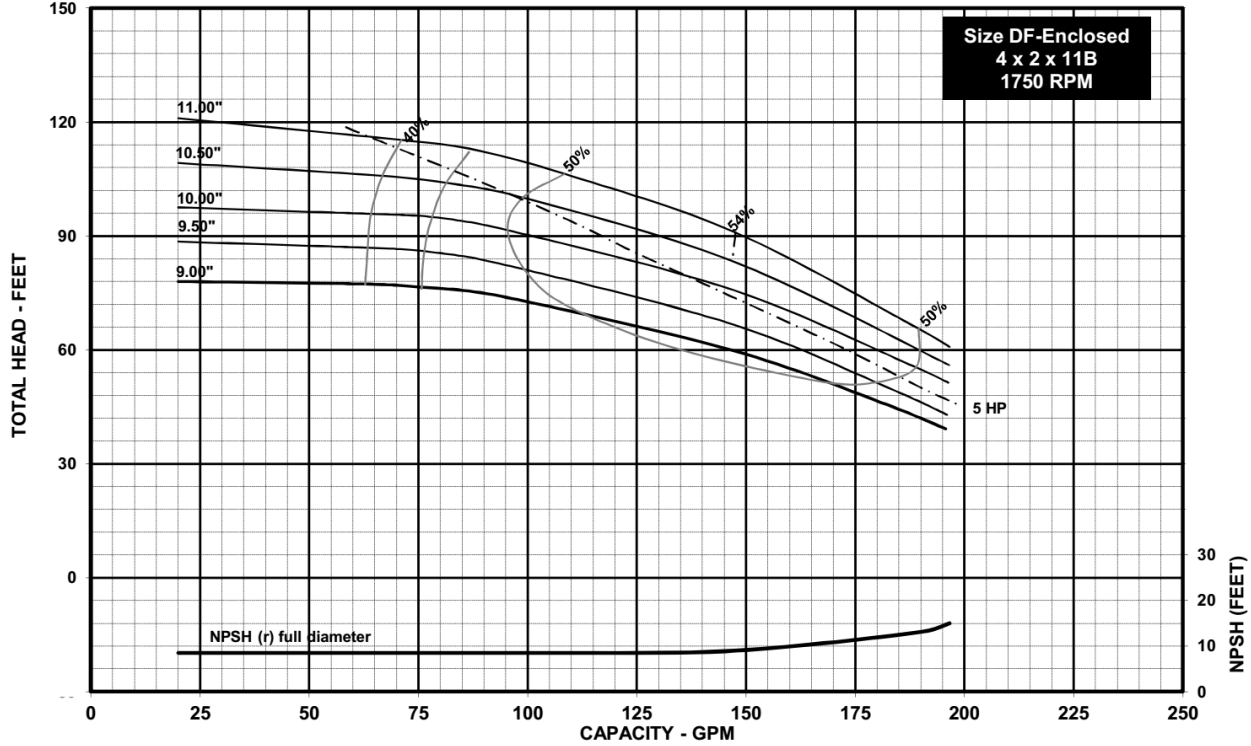
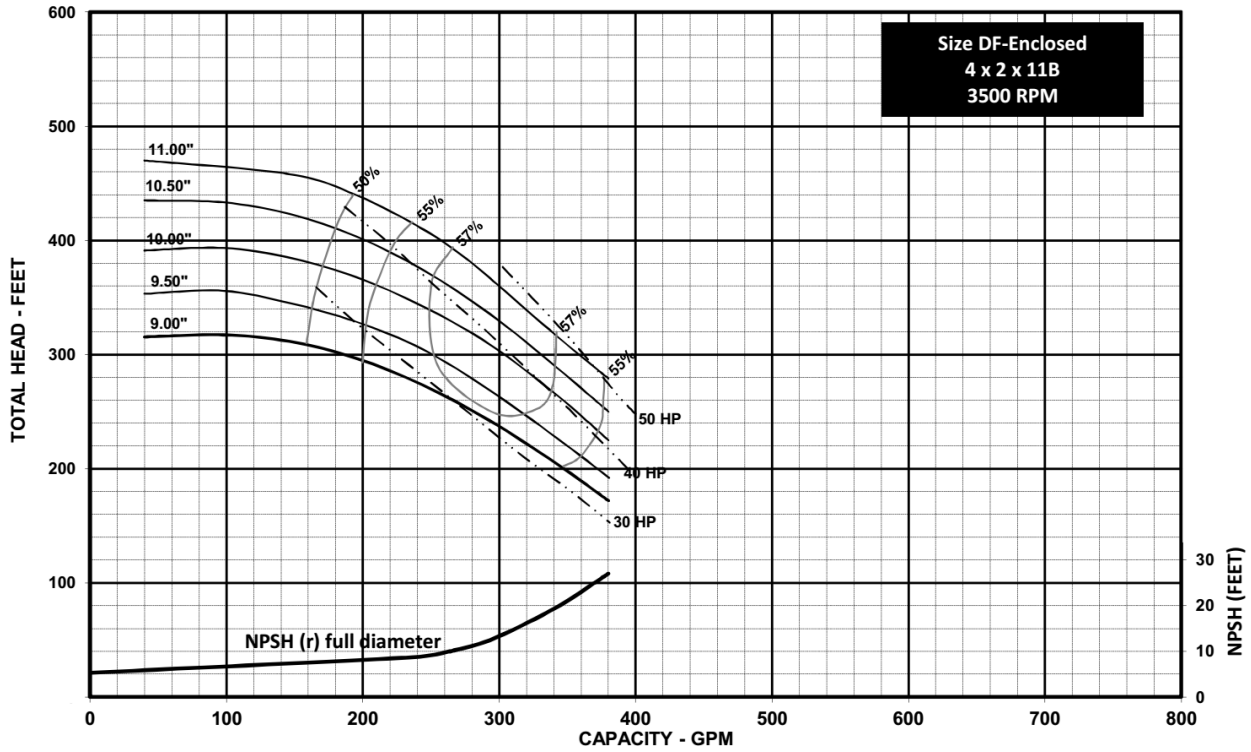

**Notes:**

1. Above data is based on 1.0 sp. gr. water at ambient temperature and pressure in accordance with Hydraulic Institute guidelines.
2. Impeller diameters between minimum and maximum shown are available in 1/8 inch increment trims.

Hydraulic Performance – 11” Impeller Pumps

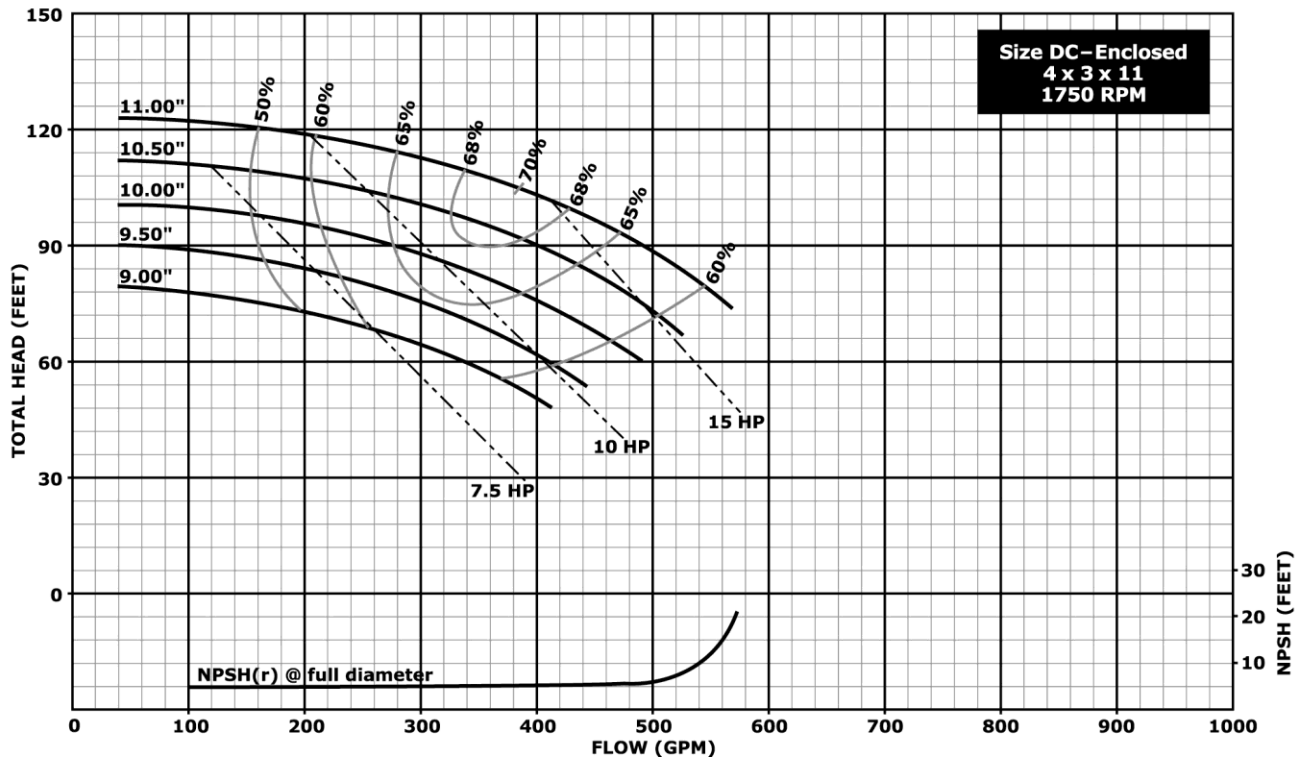
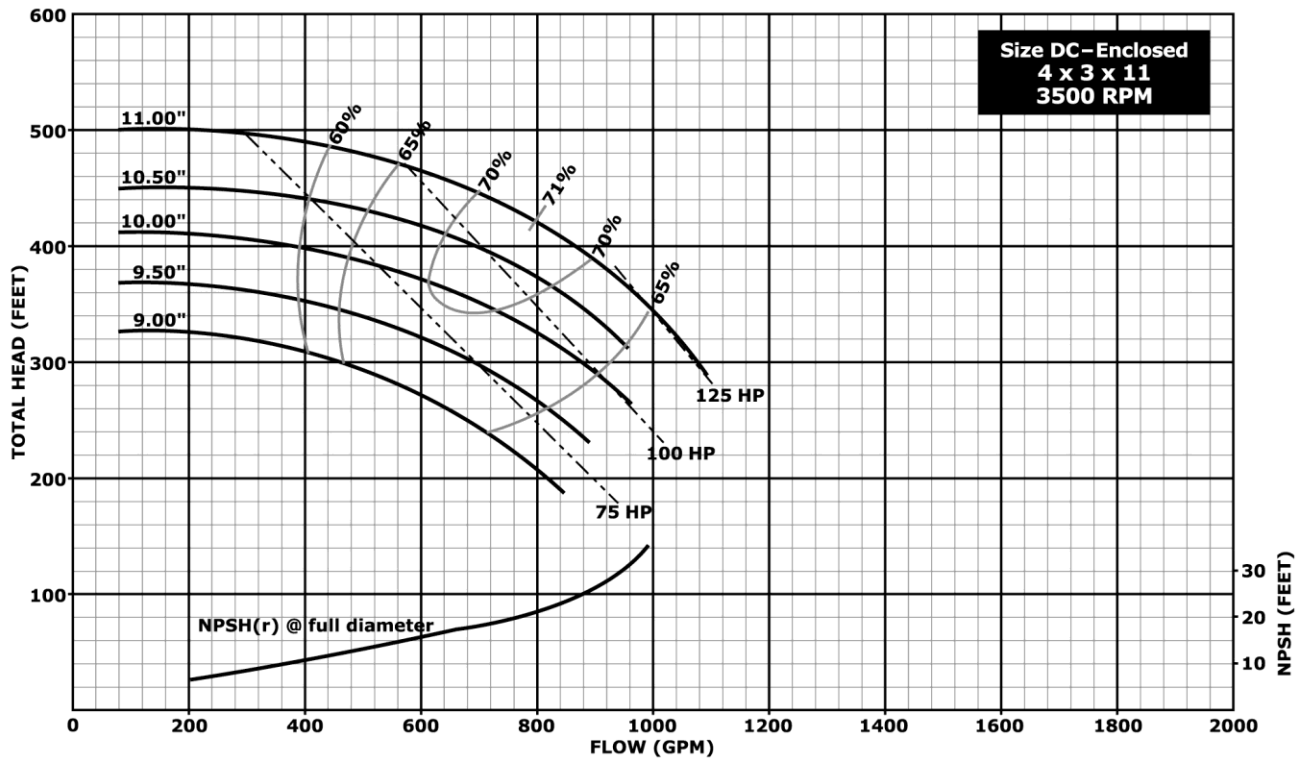

**Notes:**

1. Above data is based on 1.0 sp. gr. water at ambient temperature and pressure in accordance with Hydraulic Institute guidelines.
2. Impeller diameters between minimum and maximum shown are available in 1/8 inch increment trims.

### Hydraulic Performance – 11" Impeller Pumps

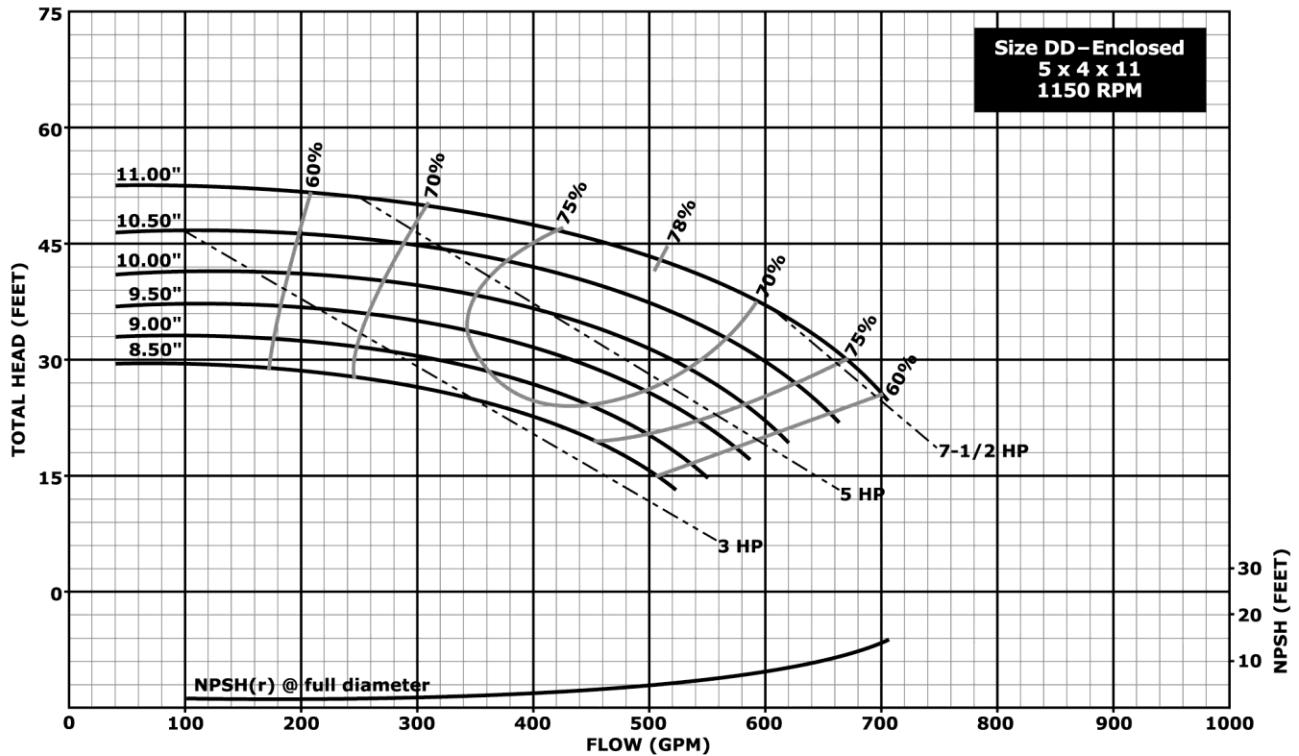
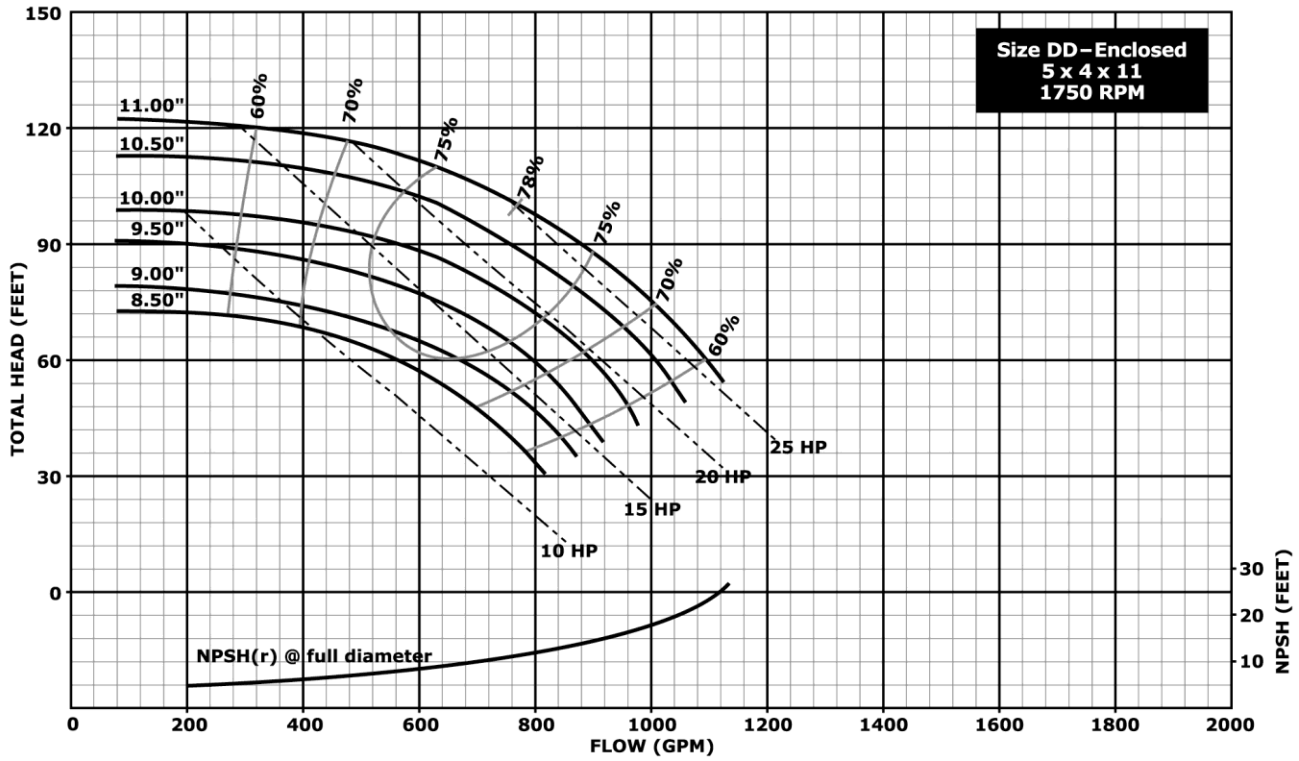

**Notes:**

1. Above data is based on 1.0 sp. gr. water at ambient temperature and pressure in accordance with Hydraulic Institute guidelines.
2. Impeller diameters between minimum and maximum shown are available in 1/8 inch increment trims.

### Hydraulic Performance – 11" Impeller Pumps

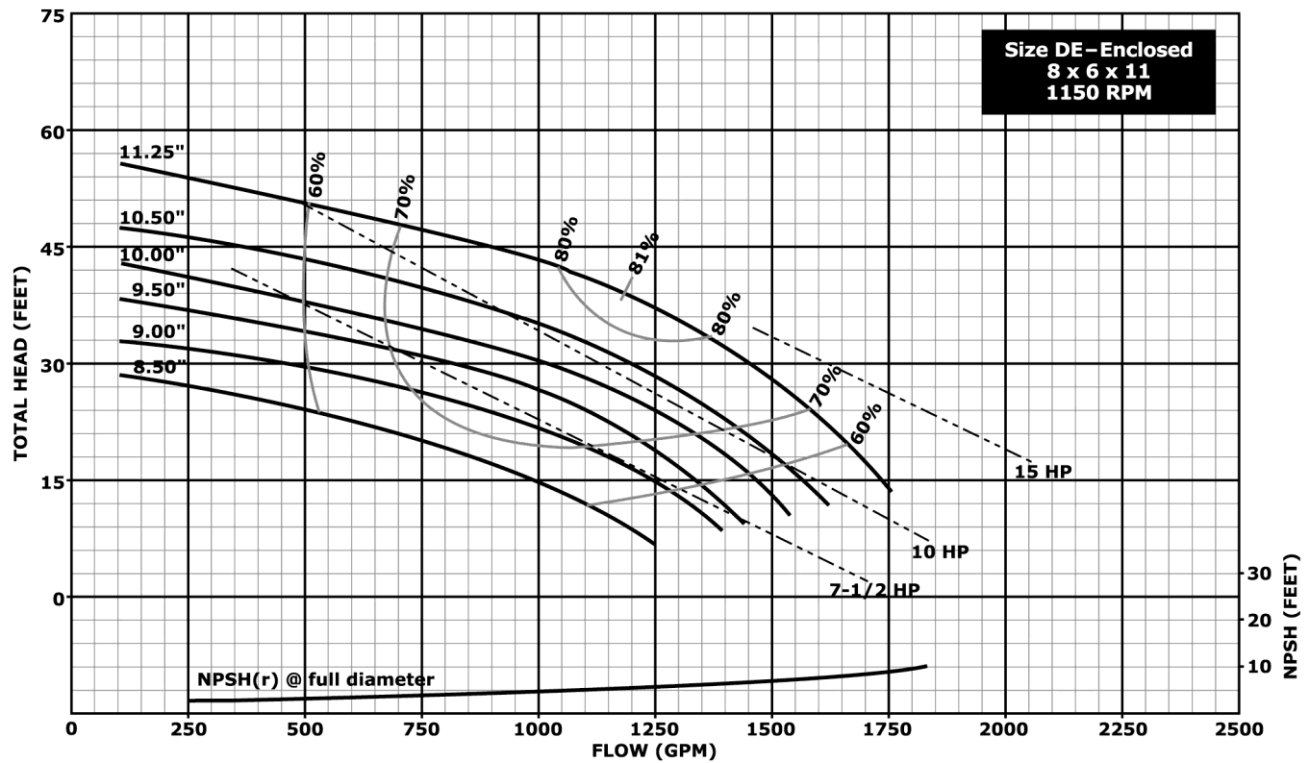
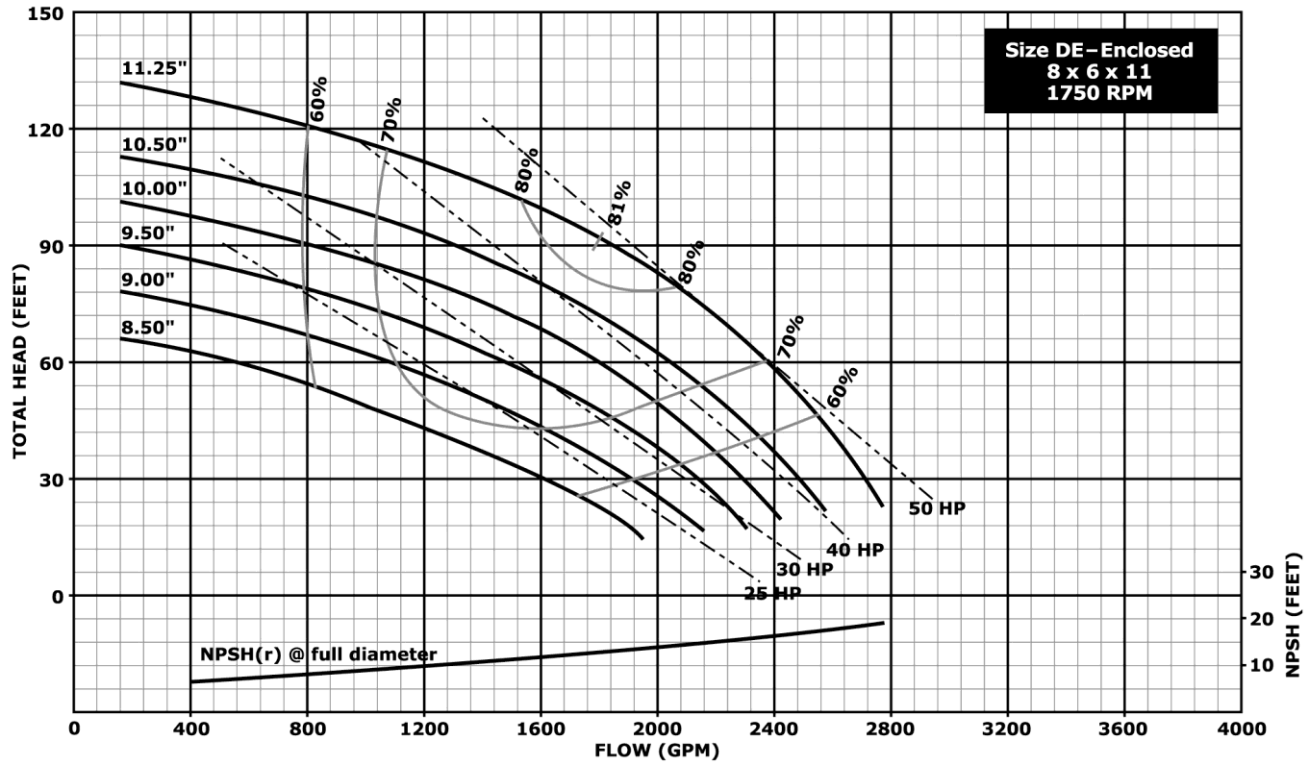

**Notes:**

1. Above data is based on 1.0 sp. gr. water at ambient temperature and pressure in accordance with Hydraulic Institute guidelines.
2. Impeller diameters between minimum and maximum shown are available in 1/8 inch increment trims.

### Hydraulic Performance – 13" Impeller Pumps

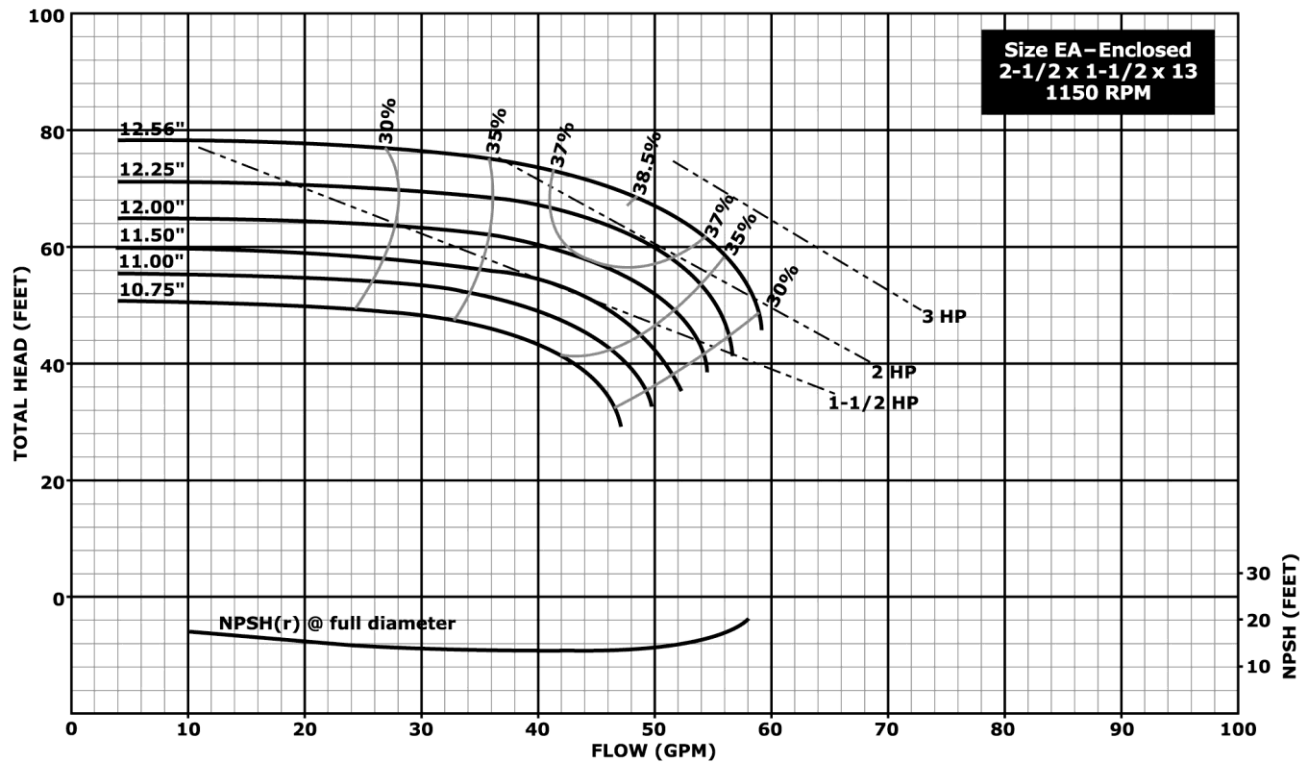
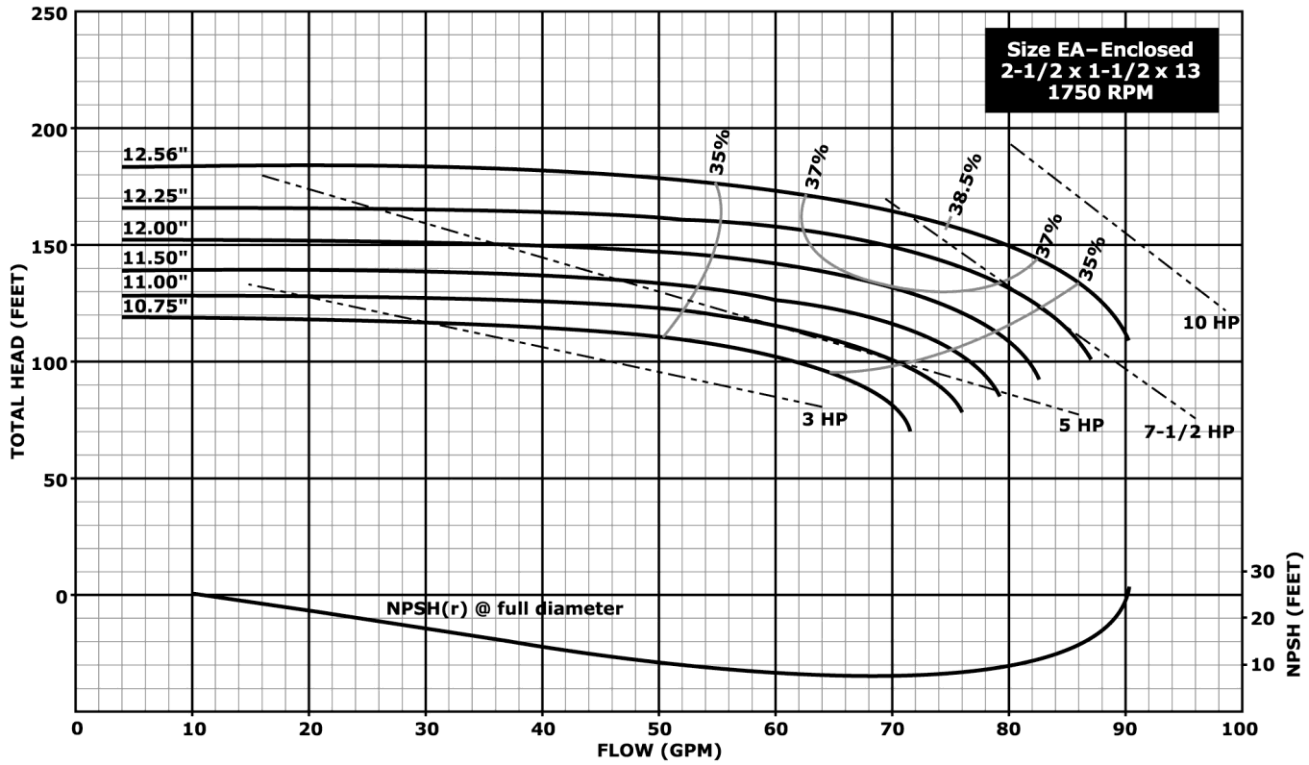

**Notes:**

1. Above data is based on 1.0 sp. gr. water at ambient temperature and pressure in accordance with Hydraulic Institute guidelines.
2. Impeller diameters between minimum and maximum shown are available in 1/8 inch increment trims.

Hydraulic Performance – 13” Impeller Pumps

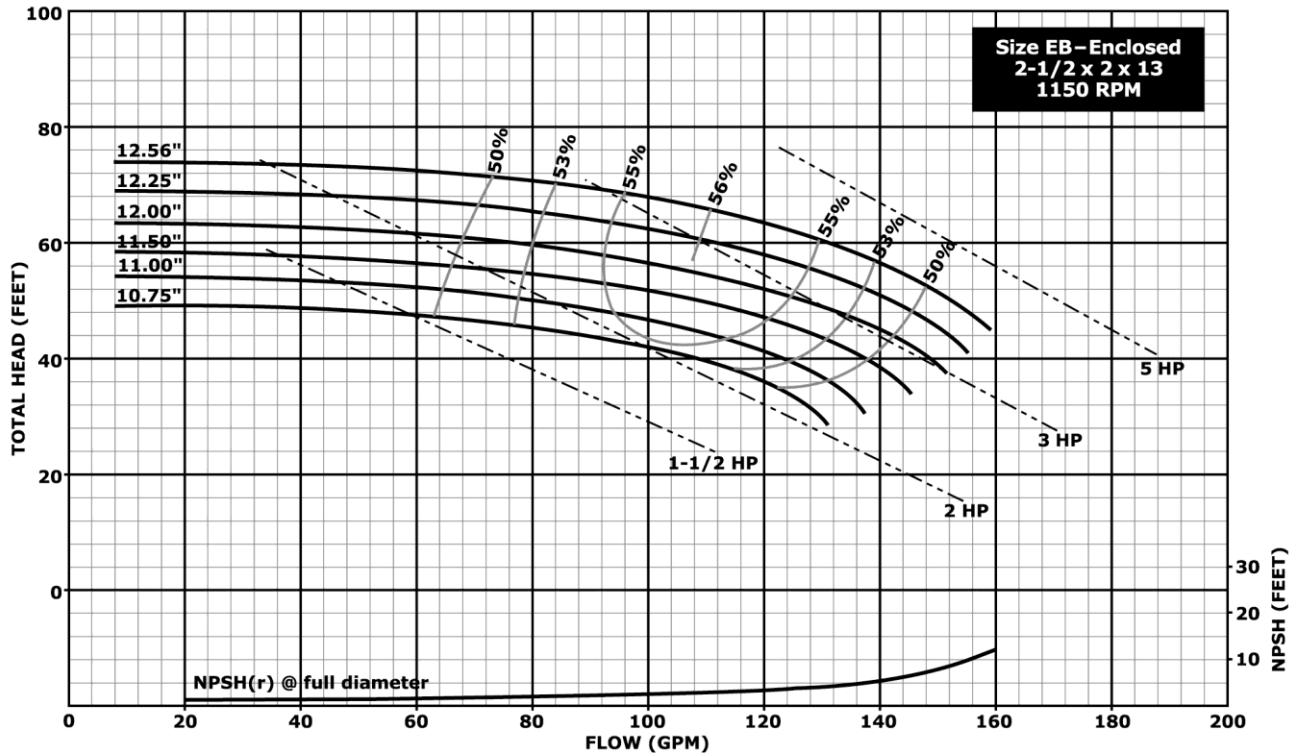
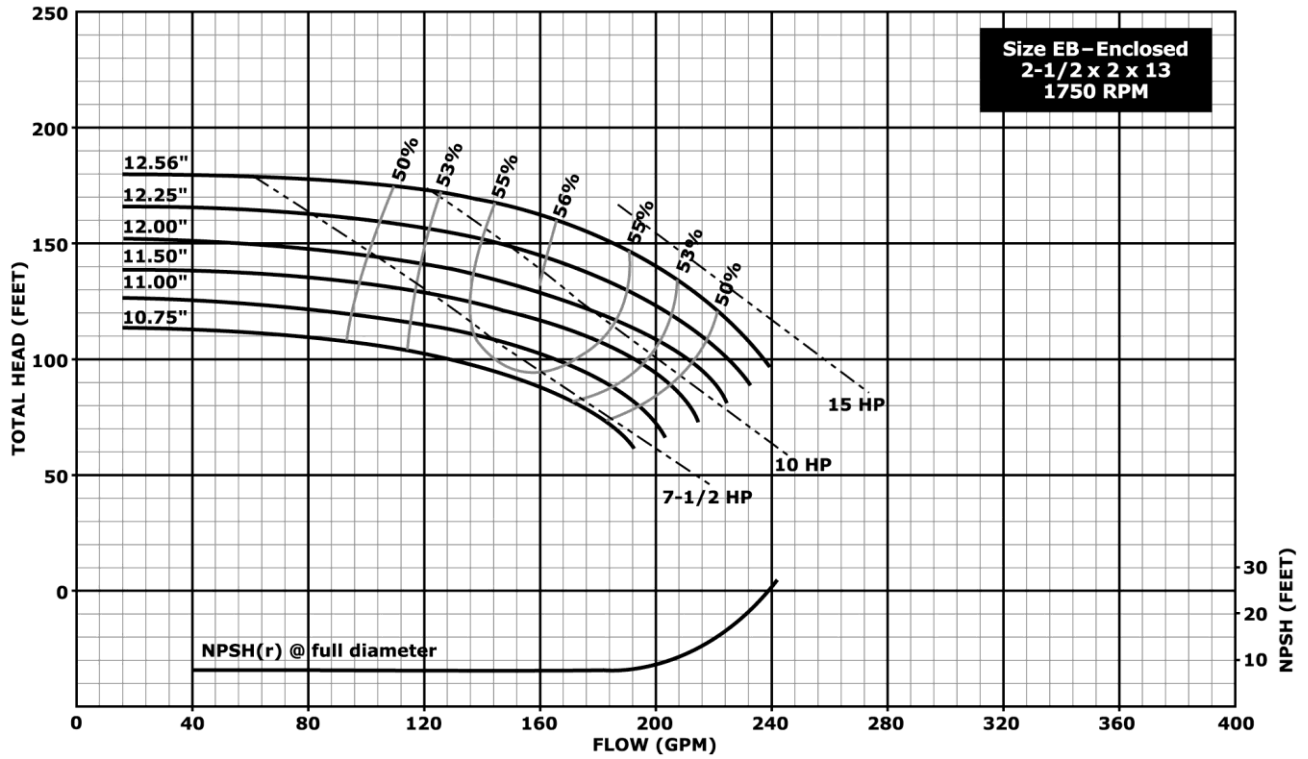

**Notes:**

1. Above data is based on 1.0 sp. gr. water at ambient temperature and pressure in accordance with Hydraulic Institute guidelines.
2. Impeller diameters between minimum and maximum shown are available in 1/8 inch increment trims.

Hydraulic Performance – 13" Impeller Pumps

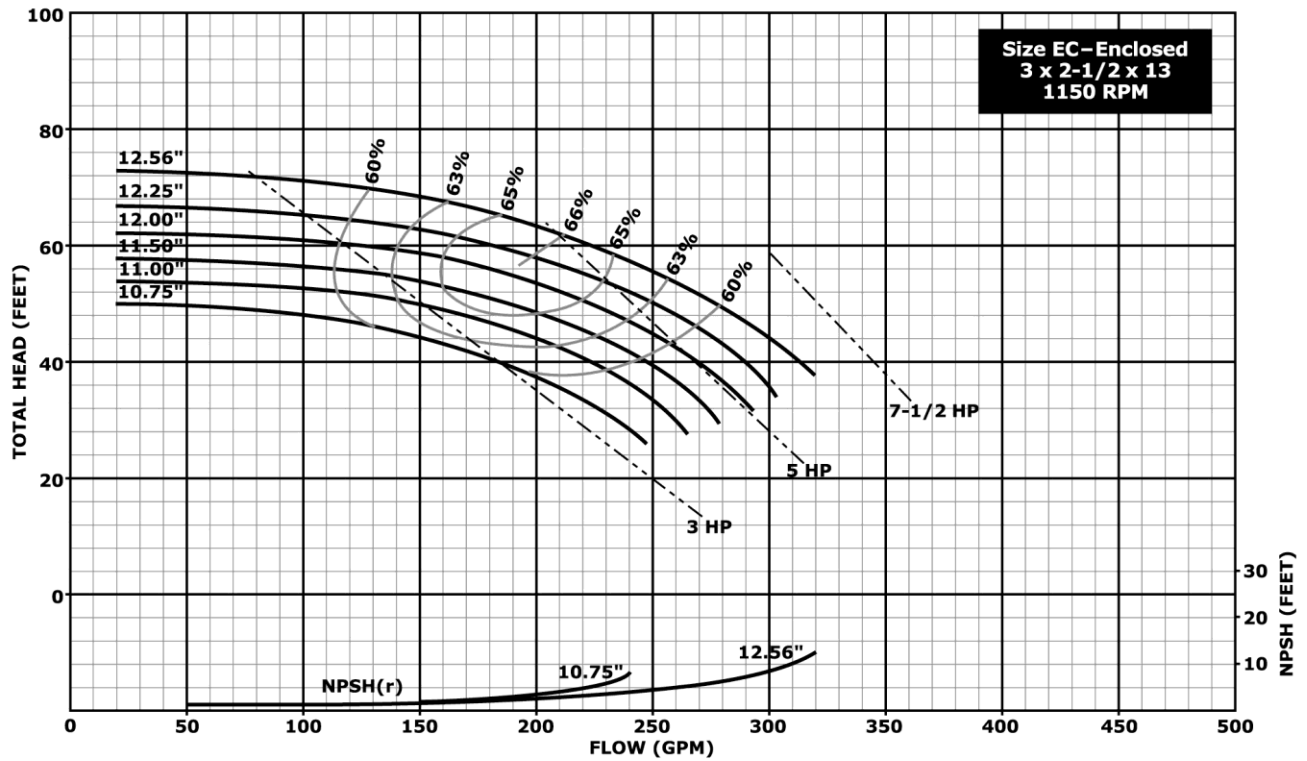
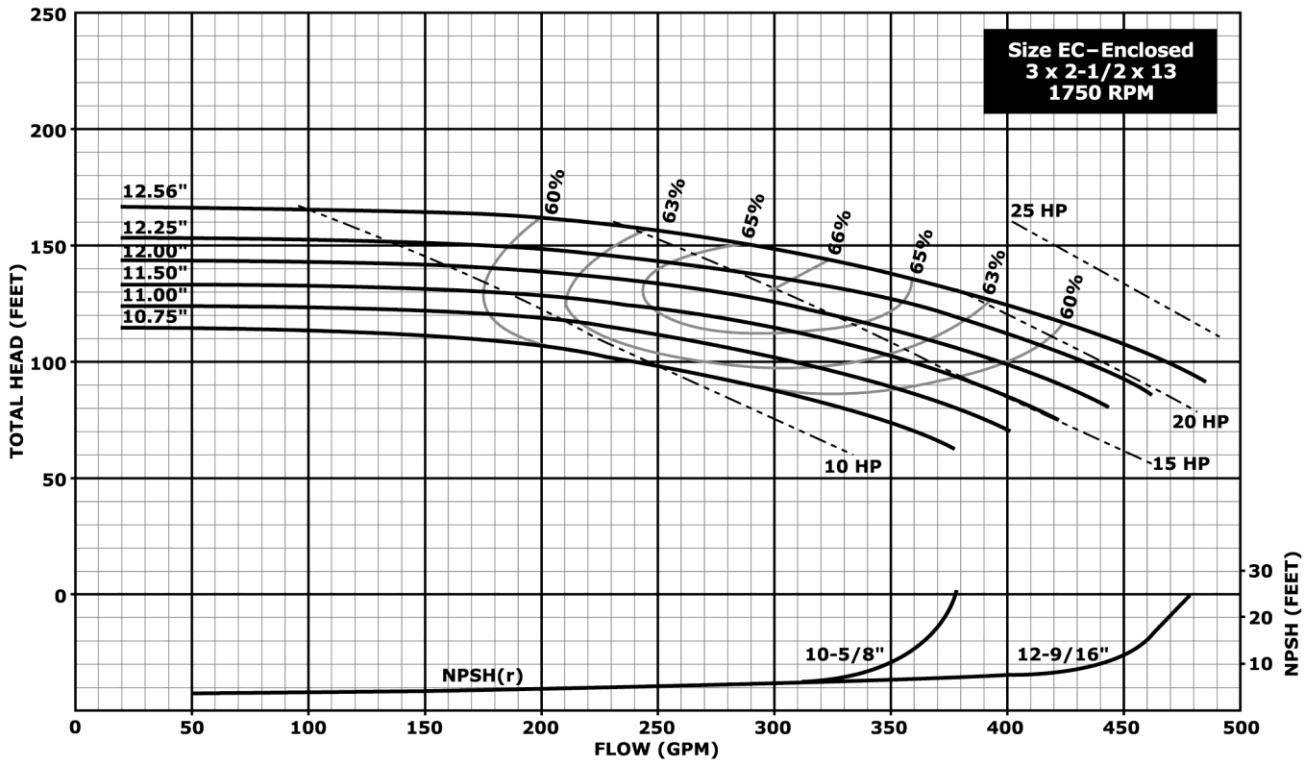

Notes:

1. Above data is based on 1.0 sp. gr. water at ambient temperature and pressure in accordance with Hydraulic Institute guidelines.
2. Impeller diameters between minimum and maximum shown are available in 1/8 inch increment trims.

**Hydraulic Performance –13" Impeller Pumps**

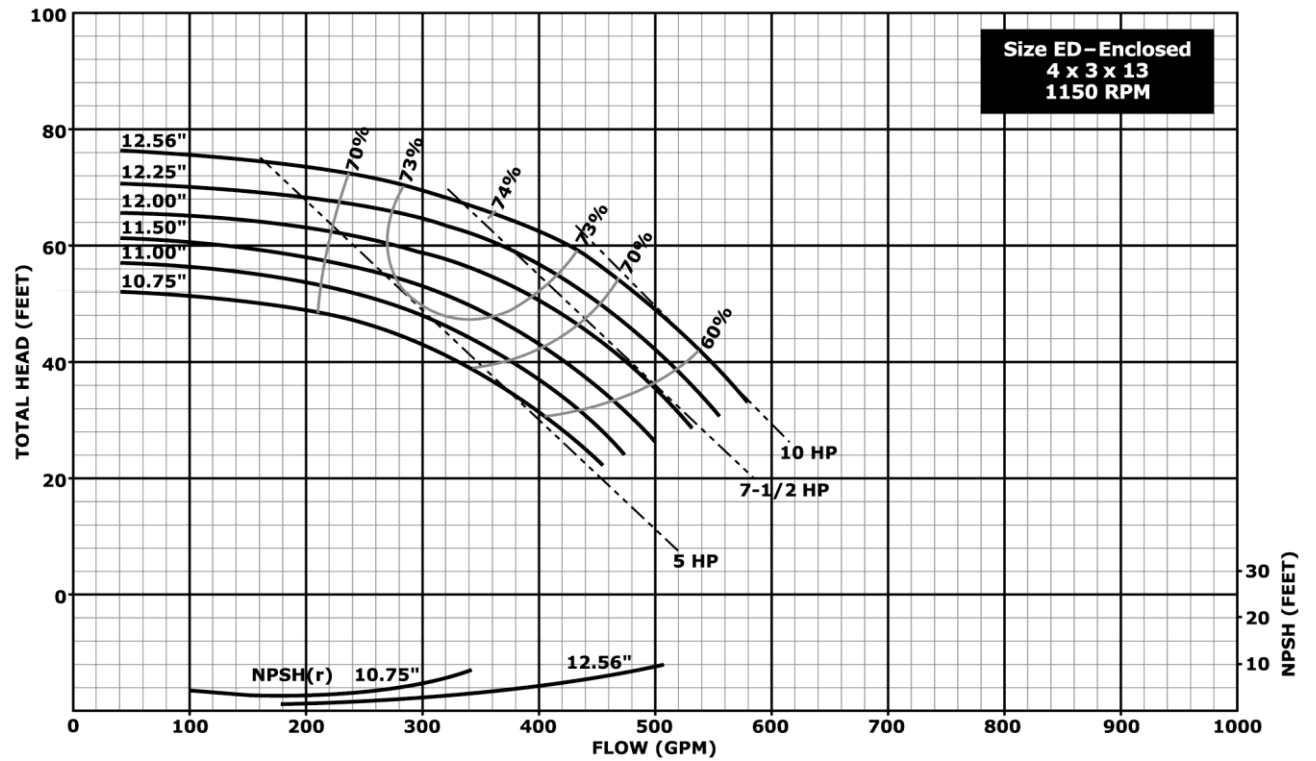
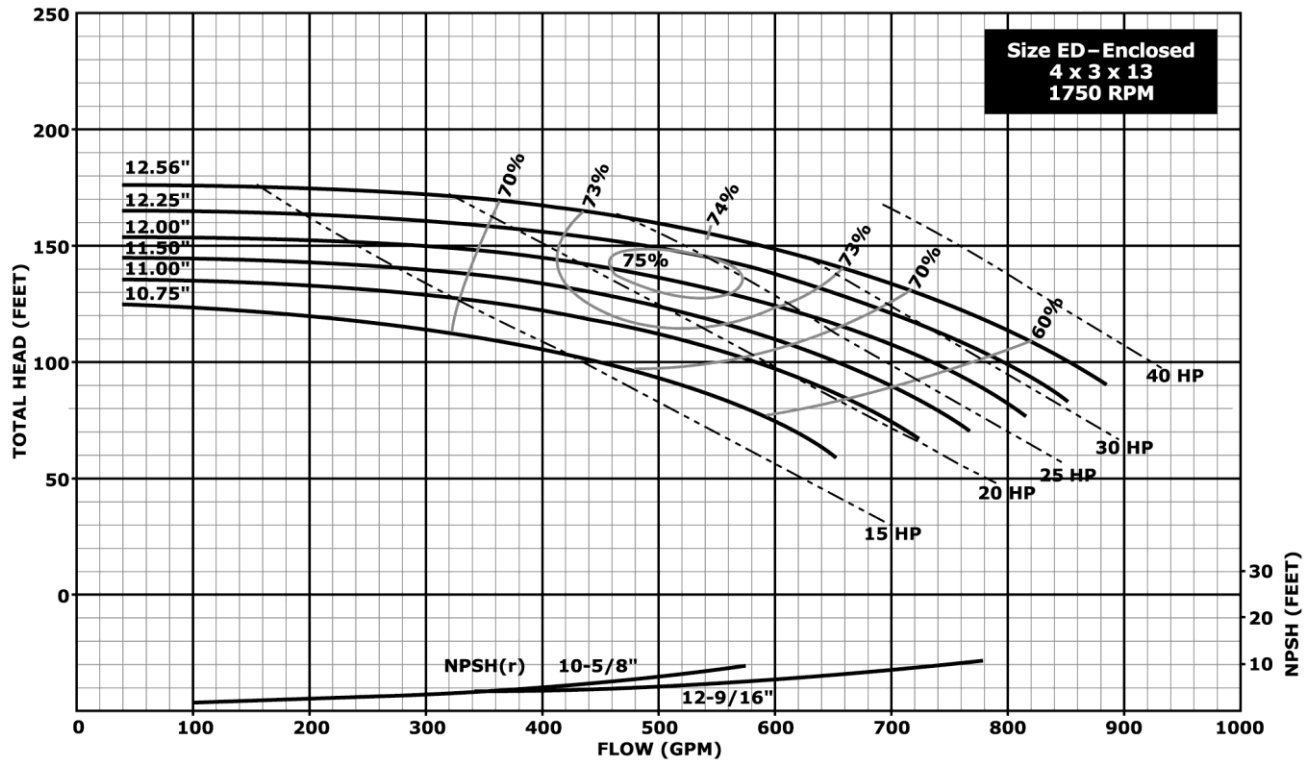

**Notes:**

1. Above data is based on 1.0 sp. gr. water at ambient temperature and pressure in accordance with Hydraulic Institute guidelines.
2. Impeller diameters between minimum and maximum shown are available in 1/8 inch increment trims.

### Hydraulic Performance – 13" Impeller Pumps

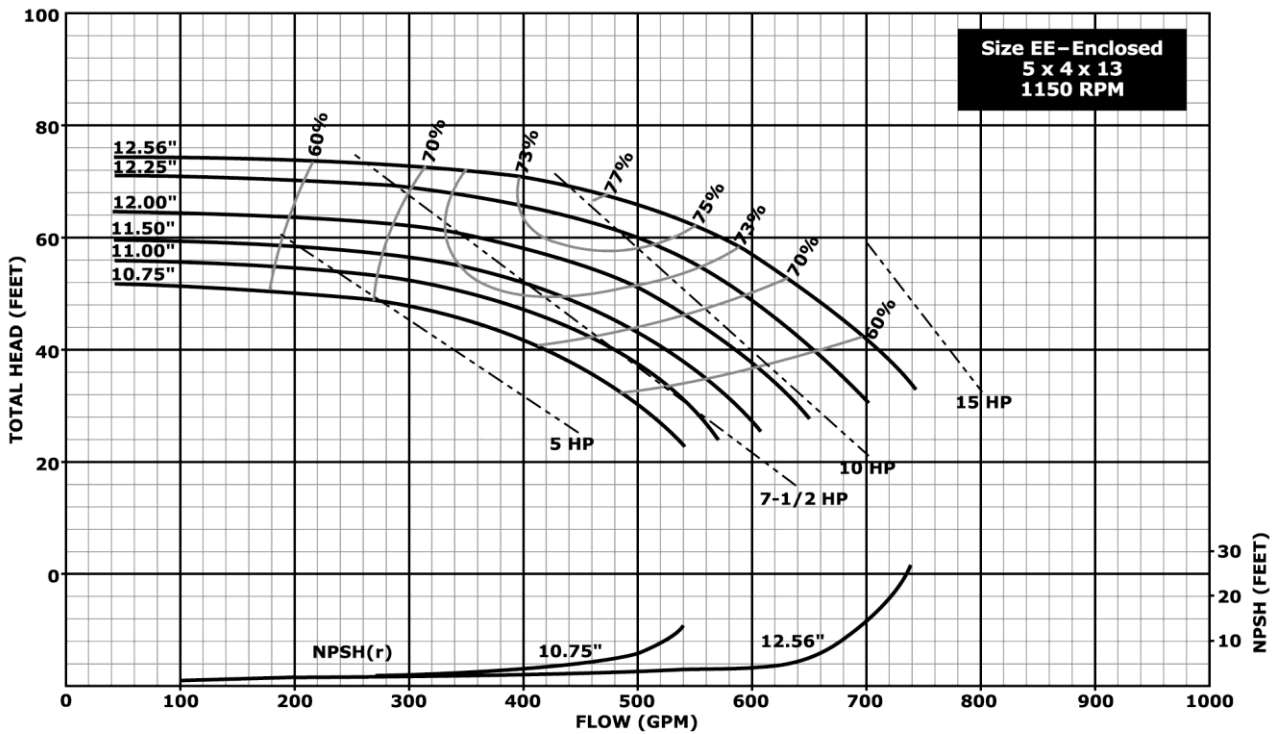
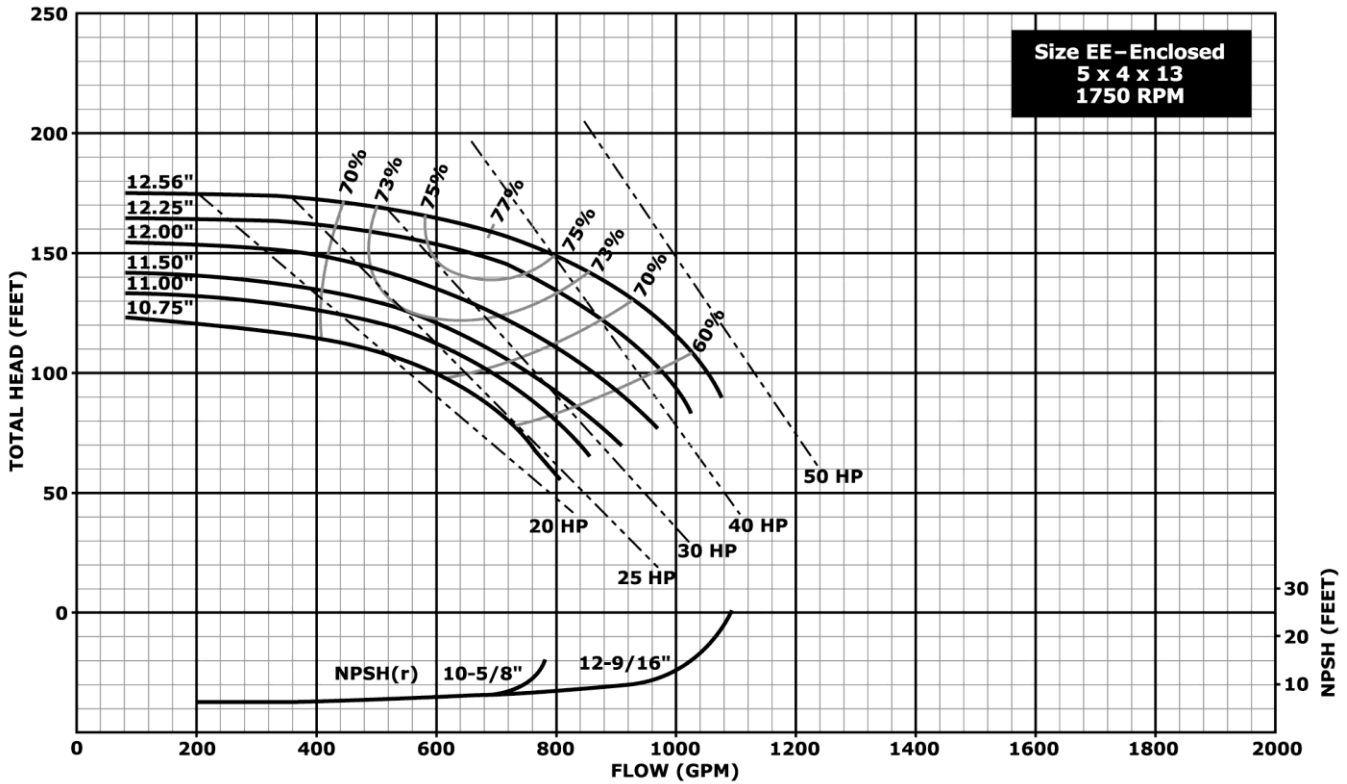

**Notes:**

1. Above data is based on 1.0 sp. gr. water at ambient temperature and pressure in accordance with Hydraulic Institute guidelines.
2. Impeller diameters between minimum and maximum shown are available in 1/8 inch increment trims.

Hydraulic Performance – 13” Impeller Pumps

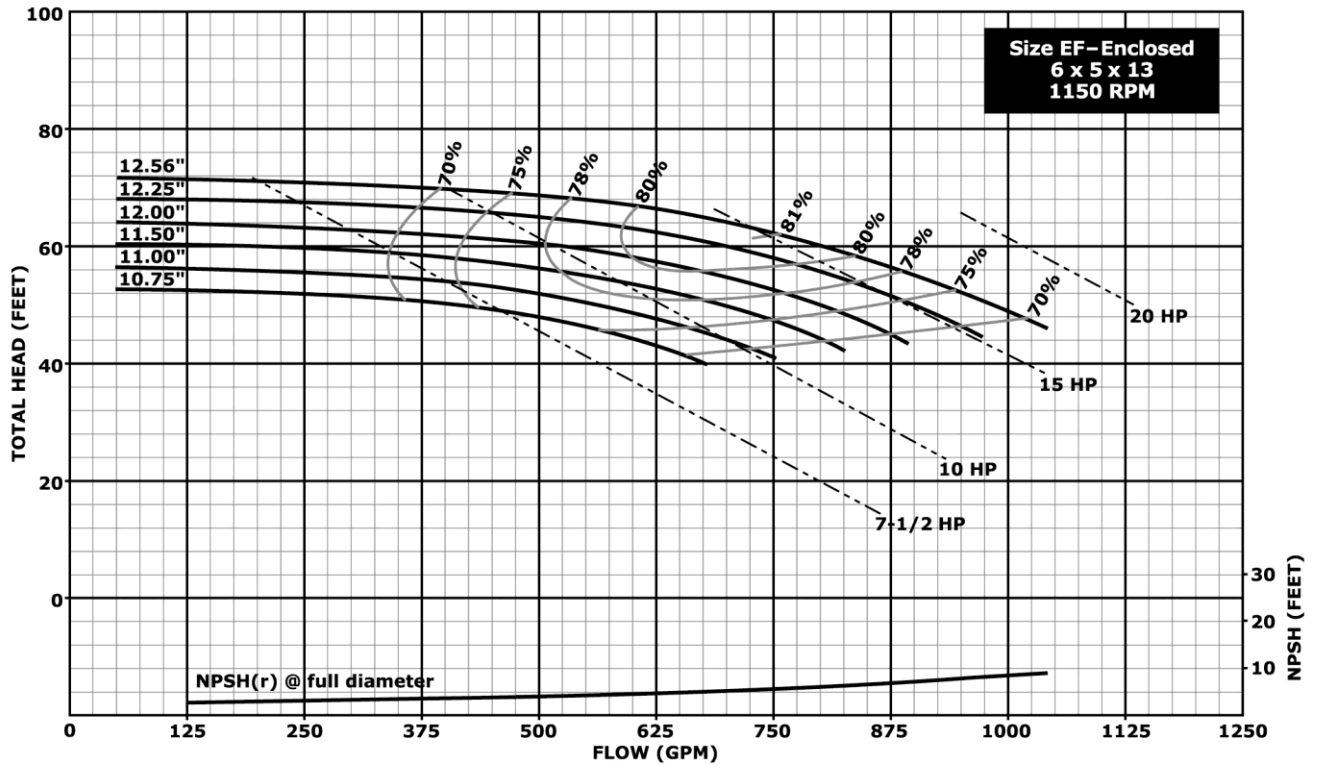
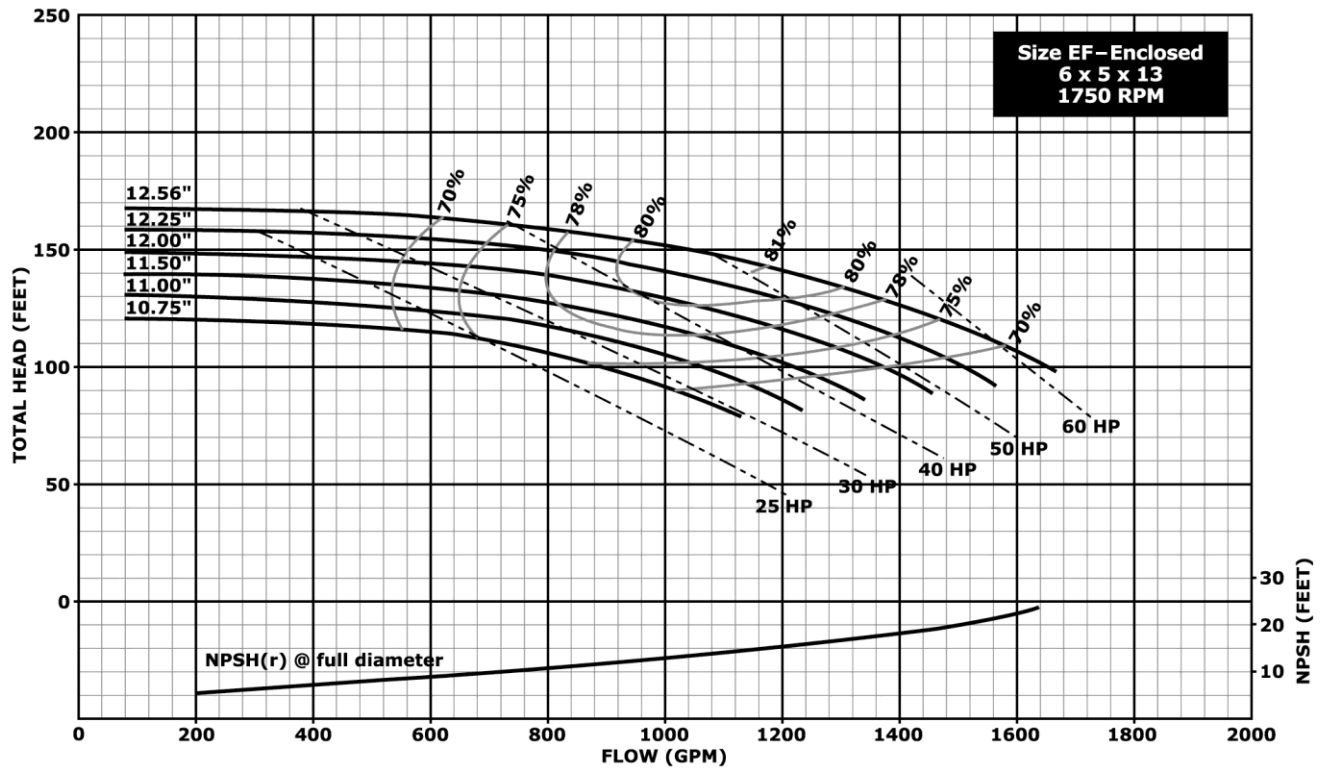

**Notes:**

1. Above data is based on 1.0 sp. gr. water at ambient temperature and pressure in accordance with Hydraulic Institute guidelines.
2. Impeller diameters between minimum and maximum shown are available in 1/8 inch increment trims.

**Hydraulic Performance – 13” Impeller Pumps**

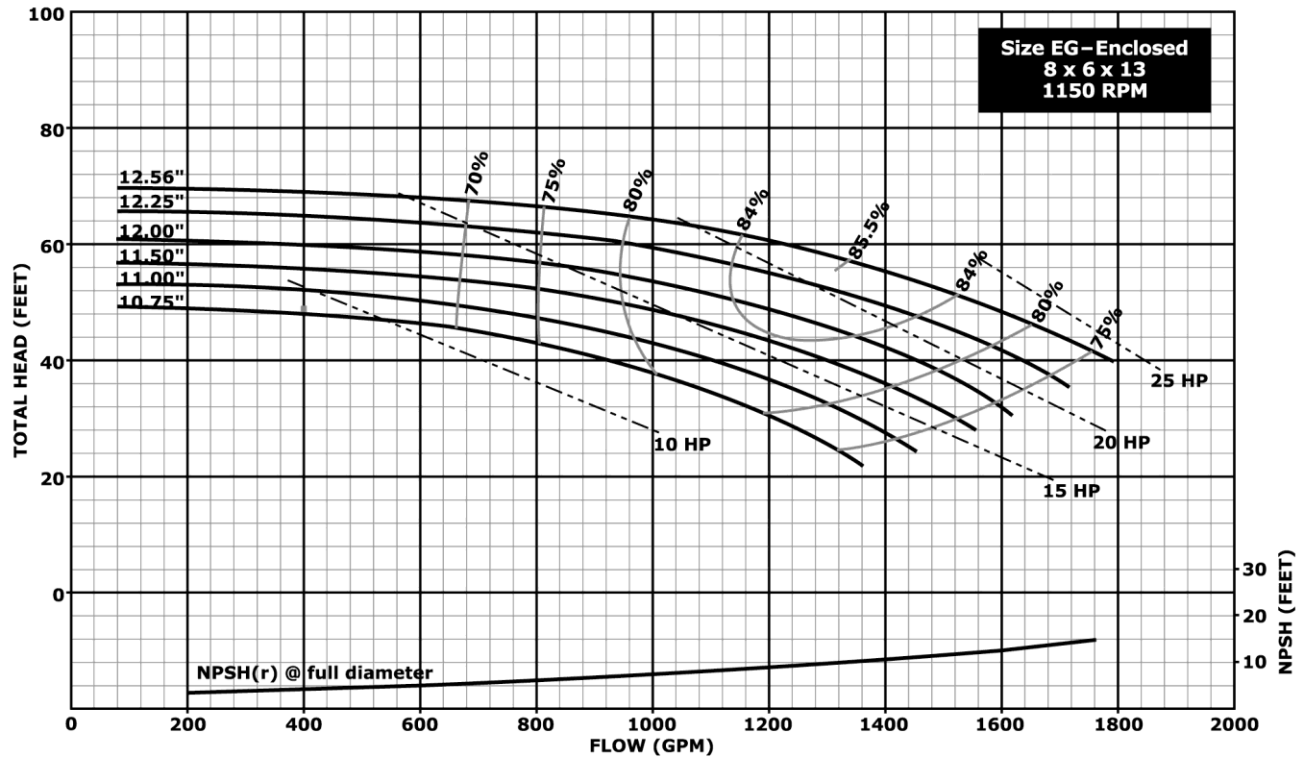
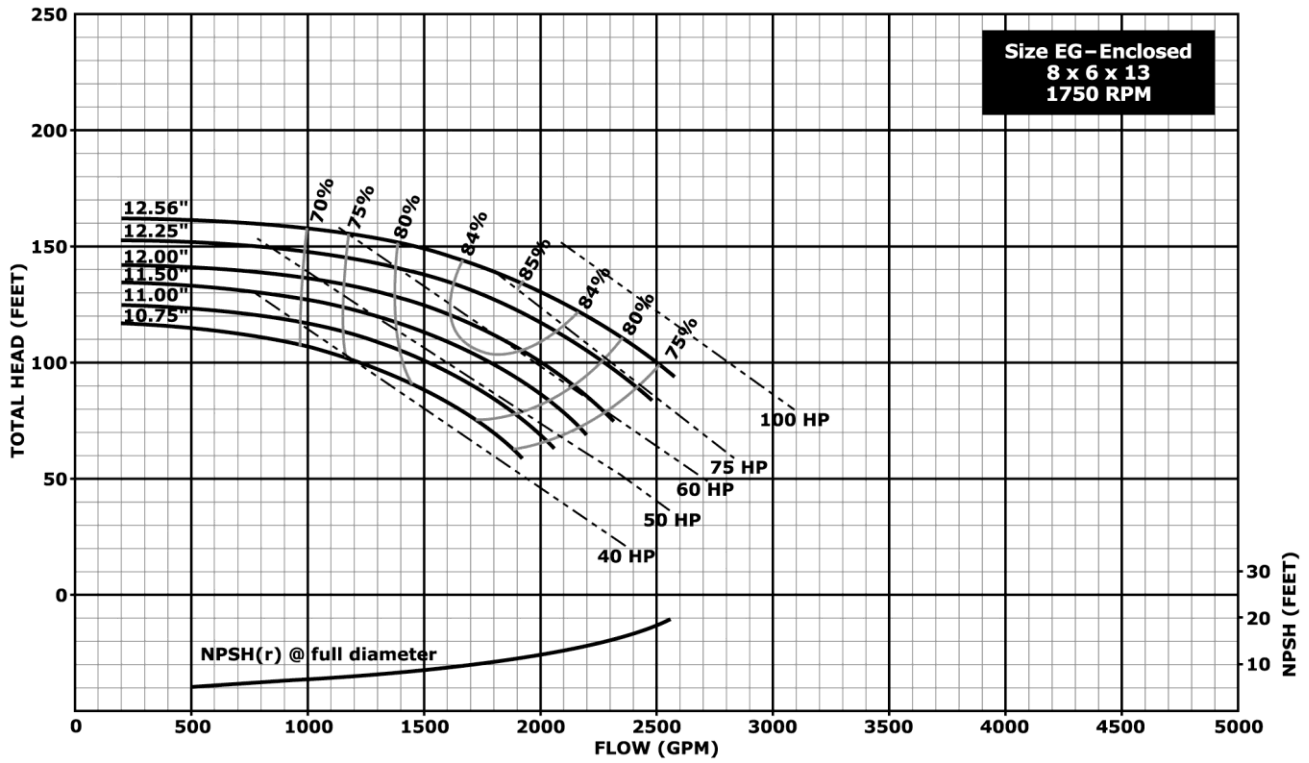

**Notes:**

1. Above data is based on 1.0 sp. gr. water at ambient temperature and pressure in accordance with Hydraulic Institute guidelines.
2. Impeller diameters between minimum and maximum shown are available in 1/8 inch increment trims.

**5", 7", 10", and 11" Impeller Sizes, Close Coupled**

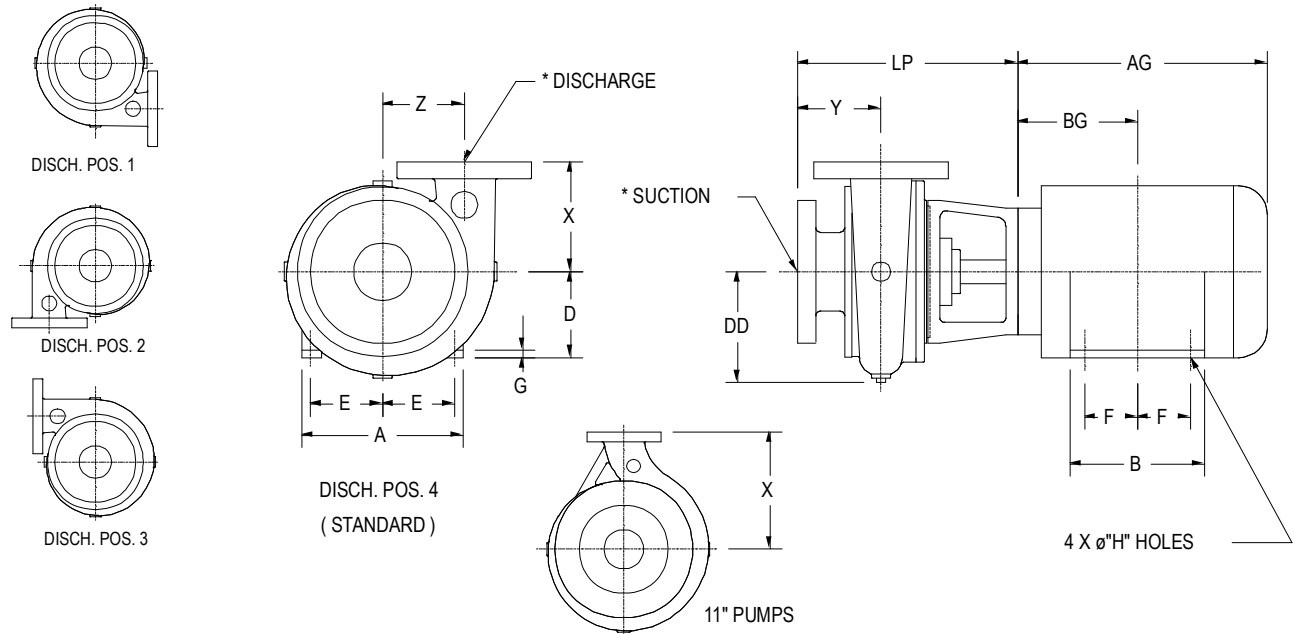

Pump Size	Pump Dimensions					
	X	Y	Z	DD	LP	
					143-184 JP	213-326 JP
1 1/4 x 1 x 5	4.00	1.72	3.00	4.00	9.30	-
2 x 1 1/2 x 5	3.50	2.05	3.25	4.75	9.61	-
2 1/2 x 2 x 5	4.50	2.38	3.50	5.00	9.98	-
1 1/4 x 1 x 7	4.25	2.65	3.81	5.25	10.24	(3)
1 1/2 x 1 1/4 x 7	4.50	3.27	4.00	5.50	9.96	(3)
2 1/2 x 2 x 7	5.00	3.75	4.13	6.00	10.77	11.58
3 x 2 1/2 x 7	5.75	4.33	4.25	6.25	11.46	12.27
4 x 3 x 7	6.00	4.90	4.50	6.75	12.21	13.02
5 x 4 x 7	7.50	5.15	4.75	7.25	12.40	13.21
1 1/2 x 1 1/4 x 10	6.00	3.30	5.25	7.00	10.29	11.58
2 x 1 1/2 x 10	6.00	4.41	5.44	8.00	10.66	11.40
2 1/2 x 2 x 10	6.25	4.81	5.50	7.25	11.50	12.25
3 x 2 1/2 x 10	7.00	5.75	5.75	8.00	12.94	13.69
4 x 3 x 10	7.00	5.38	6.00	8.25	12.56	13.31
5 x 4 x 10	8.50	4.71	6.50	9.50	11.89	12.64
6 x 5 x 10	8.38	5.81	7.63	10.75	-	14.53
2 x 1 x 11	11.00	3.94	-	7.63	11.66	12.41
4 x 2 x 11A	11.00	6.00	-	8.13	13.69	14.50
4 x 2 x 11B	11.00	6.00	-	8.13	13.69	14.50
4 x 3 x 11	12.00	6.00	-	9.00	13.69	14.50
5 x 4 x 11	10.75	6.00	-	8.75	-	14.52
8 x 6 x 11	16.00	6.50	-	11.50	-	14.62

NEMA Motor Frame	Motor Dimensions								
	A (max)	AG	B (max)	BG	D	E	F	G	H
143 JP	7.00	10.50	6.00	4.88	3.50	2.75	2.00	0.44	0.34
145 JP	7.00	11.50	6.00	5.38	3.50	2.75	2.50	0.44	0.34
182 JP	9.00	12.63	6.75	5.88	4.50	3.75	2.25	0.56	0.41
184 JP	9.00	13.63	6.75	6.38	4.50	3.75	2.75	0.56	0.41
213 JP	10.50	15.25	7.00	7.25	5.25	4.25	2.75	0.63	0.44
215 JP	10.50	16.75	8.50	8.00	5.25	4.25	3.50	0.63	0.44
254 JP	12.50	19.13	10.50	9.13	6.25	5.00	4.13	0.63	0.53
256 JP	12.50	20.88	12.25	10.0	6.25	5.00	5.00	0.63	0.53
284 JP	13.88	21.00	12.25	9.75	7.00	5.50	4.75	0.75	0.53
286 JP	13.88	22.44	13.75	10.50	7.00	5.50	5.50	0.75	0.53
324 JP	15.88	23.13	13.75	10.75	8.00	6.25	5.25	0.81	0.69
356 JP	15.88	24.63	15.25	11.50	8.00	6.25	6.00	0.81	0.69

**Notes:**

1. All 5", 7", and 10" pumps with suction sizes 1.25" thru 2.5" have NPT connections. All other Sizes have 125 lb. FF flange (cast iron) or 150 lb. FF flange (316 SS).
2. All 11" pump connections have 125 lb. FF flange (cast iron) or 150 lb. FF flange (316 SS).
3. Pumps with this size NEMA motor frame require TCZ (West Coast Shaft) frame motors.

	1. All dimensions in inches, all tolerances +/- 0.125 inch.	<p><b>Dwg: SP-GH-1, Rev: 0</b></p>
	2. All motor dimensions are approximate.	
	3. Not valid for construction unless certified.	

### 5", 7", 10", and 11" Impeller Sizes, Frame Mounted, Bare Pump

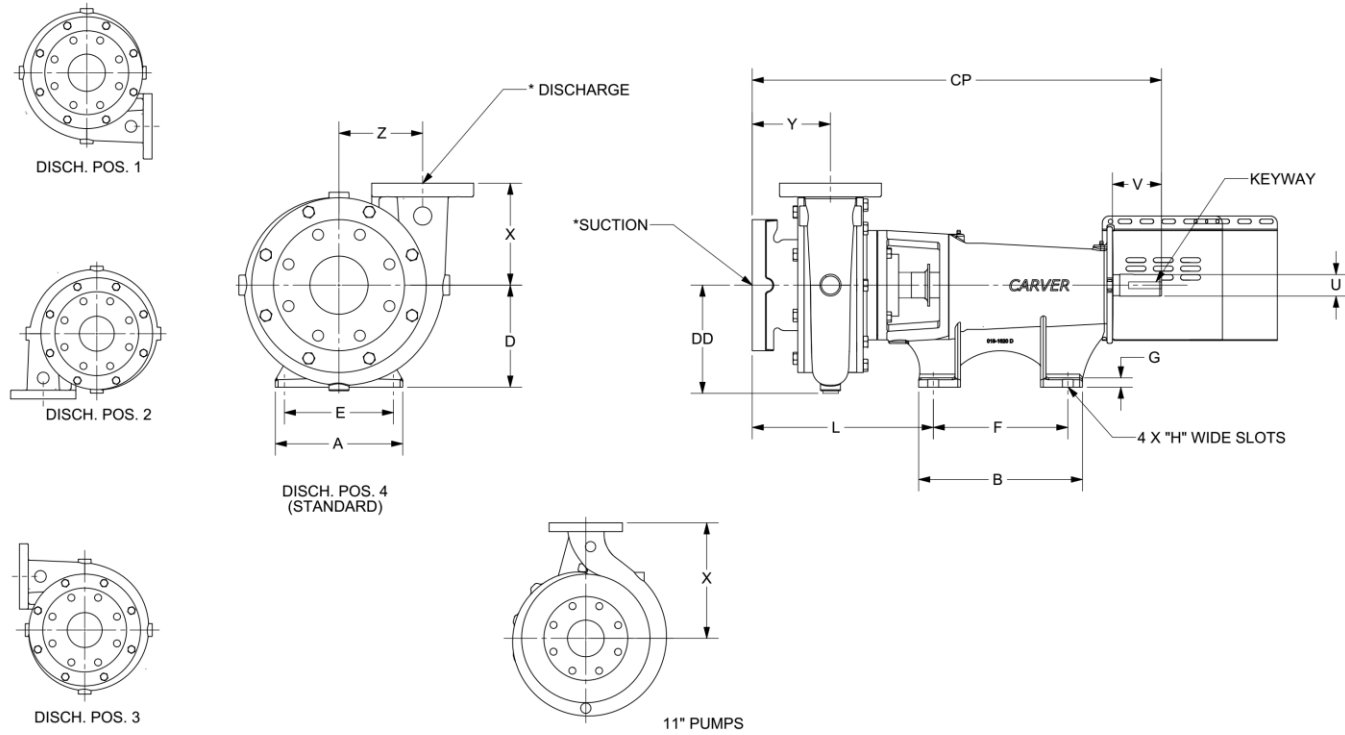

**Notes:**

- All 5", 7", and 10" pumps with suction sizes 1.25" thru 2.5" have NPT connections. All other sizes have 125 lb. FF flange (cast iron) or 150 lb. FF flange (316 SS).

Pump Size	Pump Dimensions						
	Bearing Frame	X	Y	Z	DD	L	CP
1 1/4 x 1 x 5	10 P	4.00	1.72	3.00	4.00	8.62	21.47
2 x 1 1/2 x 5		3.50	2.05	3.25	4.75	8.92	21.78
2 1/2 x 2 x 5		4.50	2.38	3.50	5.00	9.29	22.17
1 1/4 x 1 x 7	10 P	4.25	2.65	3.81	5.25	9.55	22.43
1 1/2 x 1 1/4 x 7		4.50	3.27	4.00	5.50	9.89	22.76
2 1/2 x 2 x 7		5.00	3.75	4.13	6.00	10.08	22.96
3 x 2 1/2 x 7		5.75	4.33	4.25	6.25	10.77	23.65
4 x 3 x 7		6.00	4.90	4.50	6.75	11.52	24.40
5 x 4 x 7		7.50	5.15	4.75	7.25	11.71	24.58

Pump Size	Pump Dimensions						
	Bearing Frame	X	Y	Z	DD	L	CP
1 1/2 x 1 1/4 x 10	20 P	6.00	3.30	5.25	7.00	10.22	25.85
2 x 1 1/2 x 10		6.00	4.41	5.44	8.00	10.59	26.22
2 1/2 x 2 x 10		6.25	4.81	5.50	7.25	11.44	27.06
3 x 2 1/2 x 10		7.00	5.75	5.75	8.00	12.88	28.50
4 x 3 x 10		7.00	5.38	6.00	8.25	12.50	28.13
5 x 4 x 10		8.50	4.71	6.50	9.50	11.83	27.46
6 x 5 x 10		8.38	5.81	7.63	10.75	13.72	29.34
2 x 1 x 11	20 P	11.00	3.94	-	7.63	11.59	27.22
4 x 2 x 11A		11.00	6.00	-	8.13	13.69	29.31
4 x 2 x 11B		11.00	6.00	-	8.13	13.69	29.31
4 x 3 x 11		12.00	6.00	-	9.00	13.69	29.31
5 x 4 x 11		10.75	6.00	-	8.75	13.71	29.34
8 x 6 x 11		16.00	6.50	-	11.5	13.81	29.43

Bearing Frame	Bearing Frame Dimensions									
	A	B	D	E	F	G	H	U	V	Keyway
10 P	6.00	8.81	5.25	5.00	7.00	0.44	0.63	1.25	2.66	0.250" x 0.125" x 2.00" long
20 P	8.75	11.25	7.00	7.50	9.25	0.50	0.75	1.50	3.8	0.375" x 0.188" x 2.13" long

	<ol style="list-style-type: none"> <li>All dimensions in inches, all tolerances +/- 0.125 inch.</li> <li>All motor dimensions are approximate.</li> <li>Not valid for construction unless certified.</li> </ol>	<b>Dwg: SP-GH-2, Rev: 2</b>
--	---	-----------------------------

**5", 7", 10" and 11" Impeller Sizes, Frame Mounted With Coupling and Base**

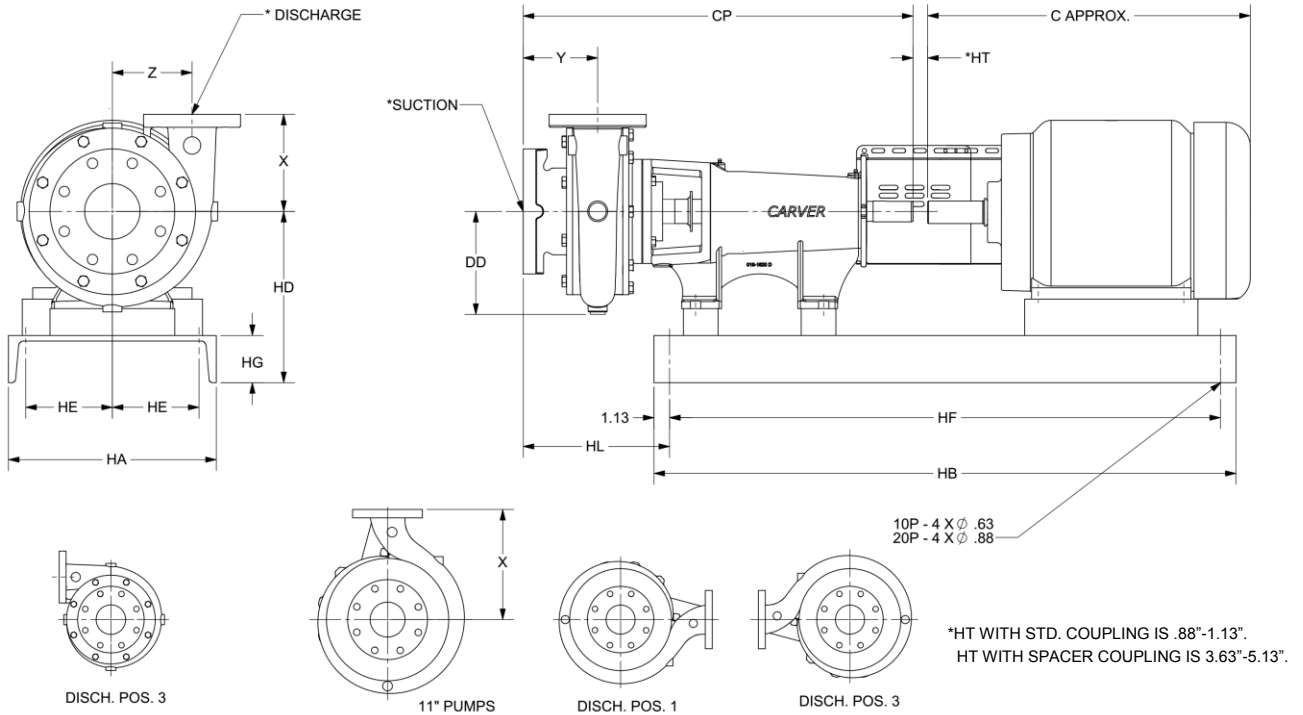

Pump Size	Pump Dimensions						
	Bearing Frame	X	Y	Z	DD	CP	HL
1 1/4 x 1 x 5	10 P	4.00	1.72	3.00	4.00	21.47	7.75
2 x 1 1/2 x 5		3.50	2.05	3.25	4.75	21.78	8.04
2 1/2 x 2 x 5		4.50	2.25	3.50	5.00	22.00	8.41
1 1/4 x 1 x 7	10 P	4.25	2.65	3.81	5.25	22.43	8.67
1 1/2 x 1 1/4 x 7		4.50	3.27	4.00	5.50	22.15	8.39
2 1/2 x 2 x 7		5.00	3.75	4.13	6.00	22.96	9.20
3 x 2 1/2 x 7		5.75	4.33	4.25	6.25	23.65	9.89
4 x 3 x 7		6.00	4.88	4.50	6.75	24.40	10.64
5 x 4 x 7		7.50	5.15	4.75	7.25	24.58	10.83

NEMA Motor Frame	Motor and Base Dimensions for 5" and 7" Pumps								
	C	HA	HB		HD	HE	HF		HG
			Std.	Spacer			Std.	Spacer	
143 T	13	12	30	32	8.44	4.75	27.75	29.75	3.0
145 T	14	12	30	32	8.44	4.75	27.75	29.75	3.0
182 T	15	12	30	34	8.44	4.75	27.75	31.75	3.0
184 T	16	12	30	34	8.44	4.75	27.75	31.75	3.0
213 T	18	12	34	38	9.63	4.75	31.75	35.75	3.0
215 T	19	12	34	38	9.63	4.75	31.75	35.75	3.0
254 T	23	15	40	44	10.00	6.25	37.75	41.75	3.4
256 T	25	15	40	44	10.00	6.25	37.75	41.75	3.4
284 TS	25	18	44	48	12.00	7.5	41.75	45.75	4
286 TS	26	18	44	48	12.00	7.5	41.75	45.75	4
324 TS	27	18	44	48	12.88	7.5	41.75	45.75	4

Pump Size	Pump Dimensions						
	Bearing Frame	X	Y	Z	DD	CP	HL
1 1/2 x 1 1/4 x 10	20P	6.00	3.30	5.25	7.00	25.85	8.34
2 x 1 1/2 x 10		6.00	4.41	5.44	8.00	26.22	8.71
2 1/2 x 2 x 10		6.25	4.81	5.50	7.25	27.06	9.56
3 x 2 1/2 x 10		7.00	5.75	5.75	8.00	28.50	12.00
4 x 3 x 10		7.00	5.38	6.00	8.25	28.13	11.63
5 x 4 x 10		8.50	4.71	6.50	9.50	27.46	10.95
6 x 5 x 10	8.38	5.81	7.63	10.75	29.34	12.84	
2 x 1 x 11	20 P	11.00	3.94	-	7.63	27.22	9.72
4 x 2 x 11A		11.00	6.00	-	8.13	29.31	11.81
4 x 2 x 11B		11.00	6.00	-	8.13	29.31	11.81
4 x 3 x 11		12.00	6.00	-	9.00	29.31	11.81
5 x 4 x 11		10.75	6.00	-	8.75	29.34	12.83
8 x 6 x 11		16.00	6.50	-	11.5	29.43	11.93

NEMA Motor Frame	Motor and Base Dimensions for 10" and 11" Pumps								
	C	HA	HB		HD	HE	HF		HG
			Std.	Spacer			Std.	Spacer	
182 T	15	15	34	38	12.50	6.00	31.75	35.75	3.4
184 T	16	15	34	38	12.50	6.00	31.75	35.75	3.4
254 T	23	15	42	46	12.50	6.00	39.75	43.75	3.4
256 T	25	15	42	46	12.50	6.00	39.75	43.75	3.4
284 TS	25	18	46	50	12.88	7.50	43.75	47.75	4.0
286 TS	26	18	46	50	12.88	7.50	43.75	47.75	4.0
324 TS	27	18	50	54	12.88	7.50	47.75	51.75	4.0
326 TS	29	18	50	54	12.88	7.50	47.75	51.75	4.0

	1. All dimensions in inches, all tolerances +/- 0.125 inch.	<b>Dwg: SP-ETA-3, Rev: 1</b>
	2. All motor dimensions are approximate.	
	3. Not valid for construction unless certified.	

**13” Impeller Sizes, Close Coupled**

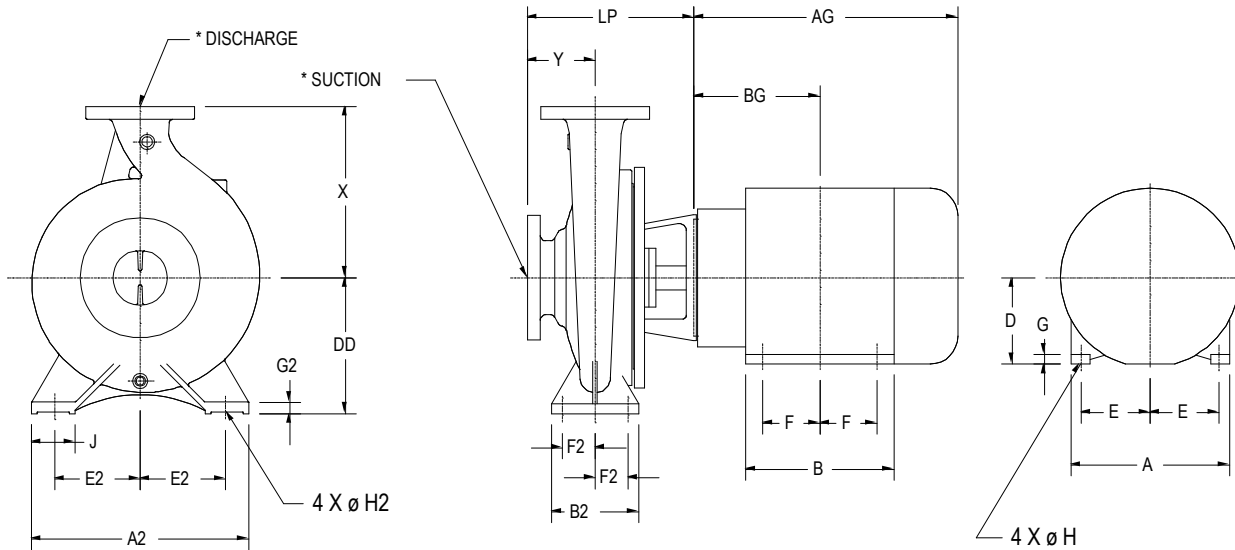

\* All flanges flat face, 125 lb. (cast iron) or 150 lb. (316 SS)

Pump Size	Pump Dimensions											
	LP		X	Y	DD	A2	B2	E2	F2	G2	H2	J
	143 - 184 JP	213 - 326 JP										
2 1/2 x 1 1/2 x 13	12.09	12.09	9.84	4.92	8.86	13.60	4.9	5.51	1.87	.67	.63	2.6
2 1/2 x 2 x 13	-	12.09	11.03	4.92	8.86	13.60	4.9	5.51	1.87	.67	.63	2.6
3 x 2 1/2 x 13	-	12.09	11.03	4.92	8.86	15.75	6.3	6.20	2.36	.71	.75	3.2
4 x 3 x 13	-	12.09	12.40	4.92	9.84	15.75	6.3	6.20	2.36	.87	.75	3.2
5 x 4 x 13	-	12.68	12.40	5.51	9.84	15.75	6.3	6.20	2.36	.71	.75	3.2
6 x 5 x 13	-	13.07	14.00	5.51	11.03	19.70	7.9	7.88	2.95	.79	.94	4.0

NEMA Motor Frame	Pump Dimensions								
	A	AG	B	BG	D	E	F	G	H
182 JP	9.0	12.63	6.75	5.88	4.50	3.75	2.25	.56	.41
184 JP	9.0	13.63	6.75	6.38	4.50	3.75	2.75	.56	.41
213 JP	10.5	15.25	7.00	7.25	5.25	4.25	2.75	.63	.44
215 JP	10.5	16.75	8.50	8.00	5.25	4.25	3.50	.63	.44
254 JP	12.5	19.13	10.50	9.13	6.25	5.00	4.13	.63	.53
256 JP	12.5	20.88	12.25	10.00	6.25	5.00	5.00	.63	.53

NEMA Motor Frame	Pump Dimensions								
	A	AG	B	BG	D	E	F	G	H
284 JP	13.88	21.00	12.25	9.75	7.00	5.50	4.75	.75	.53
286 JP	13.88	22.44	13.75	10.50	7.00	5.50	5.50	.75	.53
324 JP	15.88	23.13	13.75	10.75	8.00	6.25	5.25	.81	.69
326 JP	15.88	24.63	15.25	11.50	8.00	6.25	6.00	.81	.69
364 JP	17.00	28.00	13.75	11.75	9.00	7.00	5.63	.88	.69
365 JP	17.00	29.00	14.75	12.25	9.00	7.00	6.13	.88	.69

	1. All dimensions in inches, all tolerances +/- 0.125 inch.	<b>Dwg: SP-GH-4, Rev: 0</b>
	2. All motor dimensions are approximate.	
	3. Not valid for construction unless certified.	

**13" Impeller Sizes, Frame Mounted, Bare Pump**

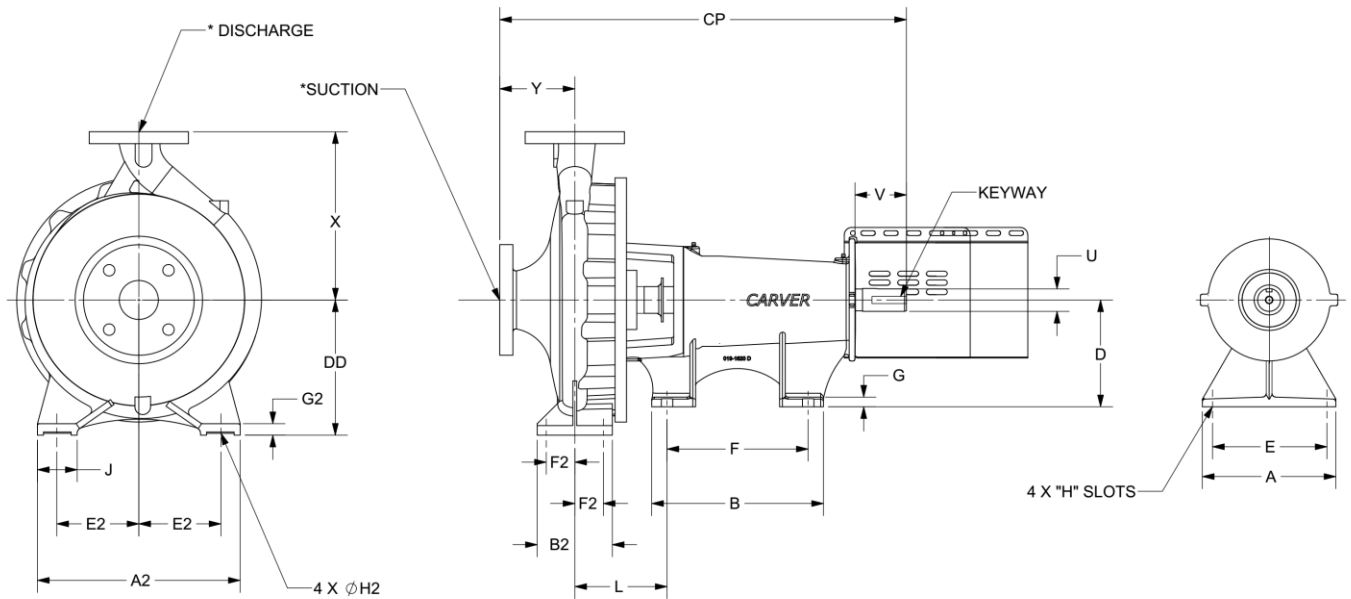

\* All flanges flat face, 125 lb. (cast iron) or 150 lb. (316 SS)

Pump Size	Pump Dimensions												
	Bearing Frame	L	CP	X	Y	DD	A2	B2	E2	F2	G2	H2	J
2 ½ x 1 ½ x 13	10 P	6.48	24.3	9.84	4.92	8.86	13.60	4.9	5.51	1.87	.67	.63	2.6
2 ½ x 2 x 13	10 P	6.48	24.3	11.03	4.92	8.86	13.60	4.9	5.51	1.87	.67	.63	2.6
3 x 2 ½ x 13	20 P	6.35	26.9	11.03	4.92	8.86	15.75	6.3	6.20	2.36	.71	.75	3.2
4 x 3 x 13	20 P	6.35	26.9	12.40	4.92	9.84	15.75	6.3	6.20	2.36	.87	.75	3.2
5 x 4 x 13	20 P	6.35	27.5	12.40	5.51	9.84	15.75	6.3	6.20	2.36	.71	.75	3.2
6 x 5 x 13	20 P	6.75	27.9	14.00	5.51	11.03	19.70	7.9	7.88	2.95	.79	.94	4.0
8 X 6 X 13	30 P	5.93	32.9	15.75	6.30	11.03	21.70	7.9	8.86	2.95	.79	.94	4.0

Bearing Frame	Bearing Frame Dimensions										Keyway
	A	B	D	E	F	G	H	U	V		
10 P	6.00	8.81	5.25	5.00	7.00	0.44	0.63	1.25	2.66	0.25" x 0.125" x 2.0" long	
20 P	8.75	11.25	7.00	7.50	9.25	0.50	0.75	1.50	3.80	0.375" x 0.188" x 2.13" long	
30 P	12.00	15.75	9.00	10.0	12.00	0.75	0.75	2.00	4.30	0.500" x 0.250" x 3.5" long	

	1. All dimensions in inches, all tolerances +/- 0.125 inch.	<b>Dwg: SP-GH-5, Rev: 2</b>
	2. All motor dimensions are approximate.	
	3. Not valid for construction unless certified.	

**13” Impeller Sizes, Frame Mounted With Coupling and Base**

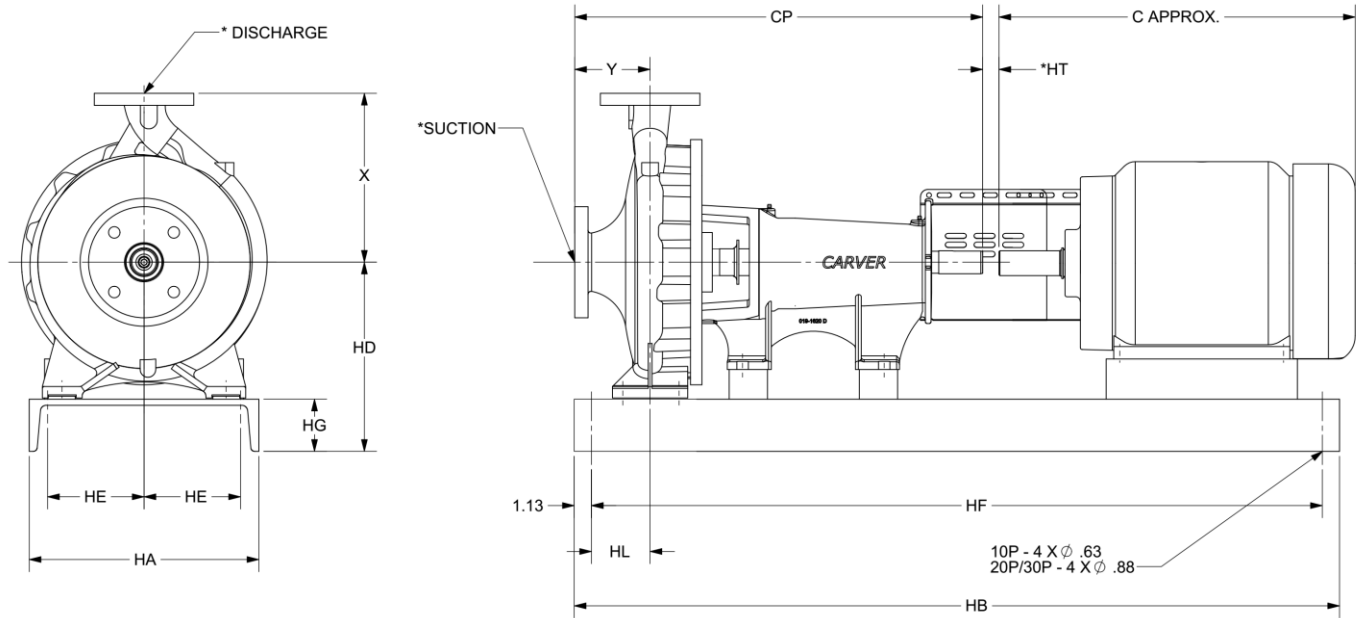

Pump Size	Pump Dimensions								
	Bearing Frame	X	Y	CP	HA	HD	HE	HG	HL
2 ½ x 1 ½ x 13	10 P	9.84	4.92	24.3	15.0	12.63	6.0	3.4	4.87
2 ½ x 2 x 13	10 P	11.03	4.92	24.3	15.0	12.63	6.0	3.4	4.87
3 x 2 ½ x 13	20 P	11.03	4.92	26.9	18.0	13.13	7.5	4.0	5.87
4 x 3 x 13	20 P	12.40	4.92	26.9	18.0	14.13	7.5	4.0	5.87
5 x 4 x 13	20 P	12.40	5.51	27.5	18.0	14.13	7.5	4.0	5.87
6 x 5 x 13	20 P	14.00	5.51	27.9	24.0	14.88	10.5	3.0	5.87
8 X 6 X 13	30 P	15.75	6.30	33.0	24.0	14.88	10.5	3.0	5.87

**Notes:**

1. Dimension "HT" with std. coupling is 0.88" – 1.13"
2. Dimension "HT" with spacer coupling is 3.63" – 5.13"
3. Cast iron flanges are 125 lb. rated flat face
4. Stainless steel flanges are 150 lb. rated flat face

NEMA Motor Frame	10 P Bearing Frame				
	C	HB		HF	
		Std.	Spacer	Std.	Spacer
182 T	15	42.0	44.0	39.75	41.75
184 T	16	42.0	44.0	39.75	41.75
213 T	18	44.0	46.0	41.75	43.75
215 T	19	44.0	46.0	41.75	43.75
254 T	23	50.0	52.0	47.75	49.75
256 T	25	50.0	52.0	47.75	49.75

NEMA Motor Frame	20 P Bearing Frame				
	C	HB		HF	
		Std.	Spacer	Std.	Spacer
213 T	18	50.0	52.0	47.75	49.75
215 T	19	50.0	52.0	47.75	49.75
254 T	23	54.0	56.0	51.75	53.75
256 T	25	54.0	56.0	51.75	53.75
284 TS	25	56.0	58.0	53.75	55.75
286 TS	26	56.0	58.0	53.75	55.75
324 TS	27	58.0	60.0	55.75	57.75
326 TS	29	58.0	60.0	55.75	57.75
364 TS	31	60.0	62.0	57.75	59.75
365 TS	32	60.0	62.0	57.75	59.75

NEMA Motor Frame	30 P Bearing Frame				
	C	HB		HF	
		Std.	Spacer	Std.	Spacer
284 TS	25	62.0	64.0	59.75	61.75
286 TS	26	62.0	64.0	59.75	61.75
324 TS	27	64.0	66.0	61.75	63.75
326 TS	29	64.0	66.0	61.75	63.75
364 TS	31	66.0	68.0	63.75	65.75
365 TS	32	66.0	68.0	63.75	65.75
404 TS	34	68.0	70.0	65.75	67.75
405 TS	35	68.0	70.0	65.75	67.75

	<ol style="list-style-type: none"> <li>1. All dimensions in inches, all tolerances +/- 0.125 inch.</li> <li>2. All motor dimensions are approximate.</li> <li>3. Not valid for construction unless certified.</li> </ol>	<p><b>Dwg: SP-GH-6, Rev: 1</b></p>
--	--	------------------------------------

This page left intentionally blank.



**CARVERPUMP™**  
**Built for purpose**

2415 Park Avenue, Muscatine, IA 52761  
Phone: 563.263.3410 [www.carverpump.com](http://www.carverpump.com)