

Maxum Series

Technical Support Information

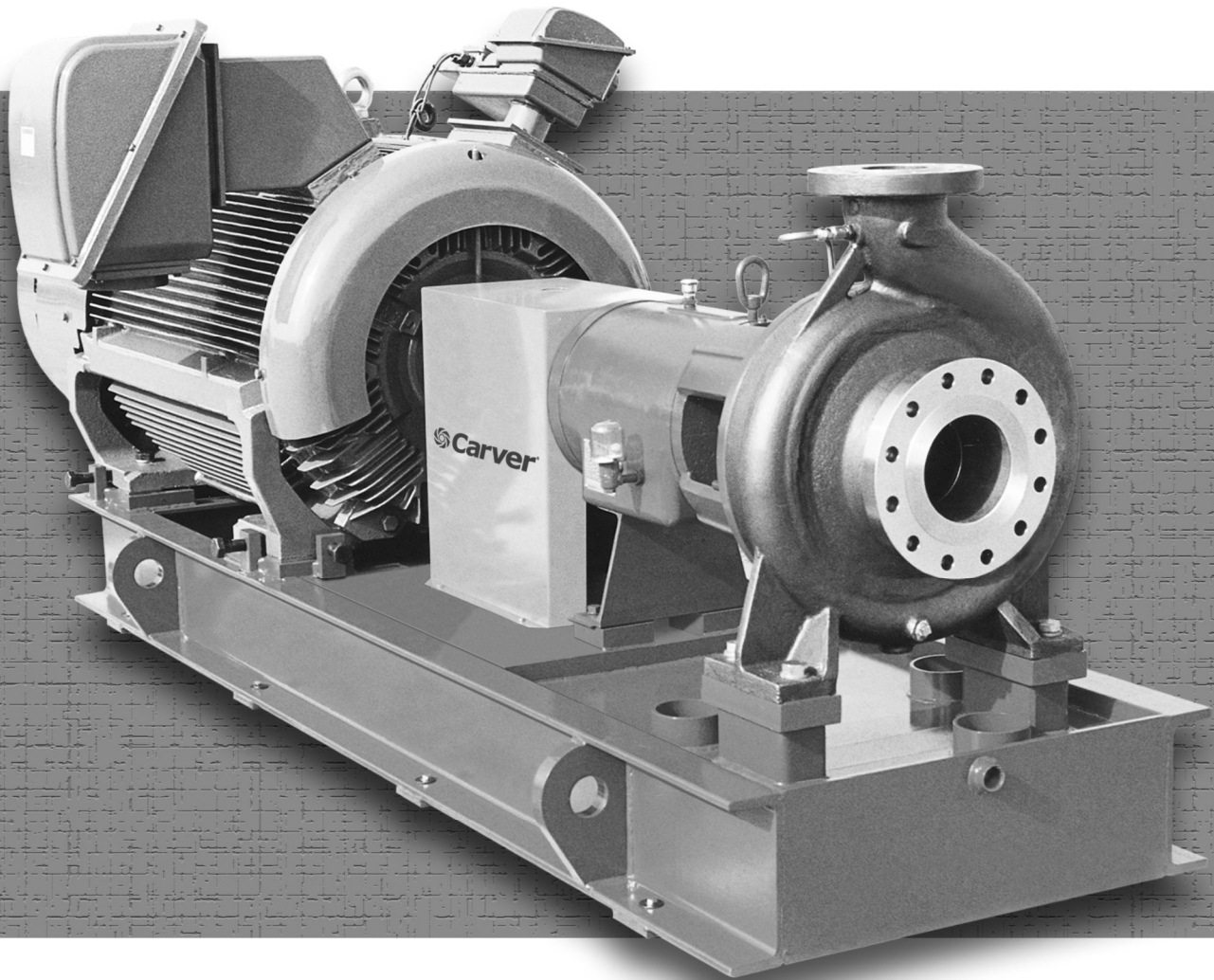

 **Carver[®]**

Creating Value.

MARCH
2006

MAXUM SERIES – MEDIUM DUTY, API END SUCTION PROCESS PUMPS

1.0 Overview

The Maxum is our medium duty process pump for handling hydrocarbons in refining and process industry applications. It is offered as a foot or centerline mounted unit. High temperature, vertical in-line, and mag-drive versions are also available. Hydraulic performance extends to 9,000 GPM and 720 feet of head.

Standard design features are given in the table below.

Basic Design Features									
Pump Size	Bearing Frame	Max Speed (RPM)	1st Critical Speed (RPM)	Casing Design		Shaft Deflection @ 20% BEP		Shaft Stiffness L³/D⁴	WK² @ Max. Impeller Dia.
				Discharge	Volute(s)	@ Seal (in.)	@ Impeller (in.)		
AA - 1½ x 1 x 6	A	3500	20,432	Centerline	Single	0.0001	0.0003	56.8	9.500
AB - 2 x 1½ x 6	A	3500	18,917	Centerline	Single	0.0001	0.0007	59.9	10.45
AC - 3 x 1½ x 6	A	3500	17,695	Centerline	Single	0.0002	0.0008	59.9	11.40
AD - 3 x 2 x 6	A	3500	18,917	Centerline	Single	0.0003	0.0014	59.6	10.45
AE - 4 x 3 x 6	A	3500	14,448	Centerline	Single	0.0005	0.0027	66.5	15.20
BA - 1½ x 1 x 8	B	3500	24,016	Centerline	Single	0.0000	0.0002	21.2	34.31
BB - 2 x 1½ x 8	B	3500	21,063	Centerline	Single	0.0001	0.0003	21.4	41.42
BC - 3 x 1½ x 8	B	3500	21,923	Centerline	Single	0.0001	0.0004	21.6	39.05
BD - 3 x 2 x 8	B	3500	21,923	Centerline	Single	0.0001	0.0006	20.4	39.05
BE - 4 x 3 x 8	B	3500	20,297	Centerline	Dual	0.0000	0.0003	23.5	43.79
BF - 6 x 4 x 8	B	3500	19,609	Centerline	Dual	0.0001	0.0004	26.7	46.16
CA - 2 x 1½ x 10	B	3500	19,609	Centerline	Single	0.0001	0.0004	21.2	92.29
CB - 3 x 1½ x 10	B	3500	19,609	Centerline	Single	0.0001	0.0004	22.2	92.29
CC - 3 x 2 x 10	B	3500	19,609	Centerline	Single	0.0001	0.0008	21.8	92.29
CD - 4 x 3 x 10	B	3500	17,901	Centerline	Single	0.0002	0.0013	23.2	108.6
CE - 6 x 4 x 10	B	3500	15,502	Centerline	Dual	0.0001	0.0004	24.6	141.3
CF - 6 x 6 x 10	B	1750	15,502	Centerline	Dual	0.0000	0.0003	26.8	141.3
CG - 8 x 6 x 10	B	1750	14,894	Centerline	Dual	0.0001	0.0005	29.5	152.2
DA - 2 x 1½ x 13	C	3500	18,926	Centerline	Dual	0.0000	0.0003	14.9	209.6
DB - 3 x 2 x 13	C	3500	19,352	Centerline	Dual	0.0001	0.0004	17.3	201.8
DC - 4 x 3 x 13	C	3500	16,572	Centerline	Dual	0.0002	0.0009	15.0	263.8
DD - 6 x 4 x 13	C	3500	15,801	Centerline	Dual	0.0000	0.0003	16.4	287.1
DE - 6 x 6 x 13	C	1750	15,125	Centerline	Dual	0.0000	0.0001	13.5	310.3
DF - 8 x 6 x 13	C	1750	14,725	Centerline	Dual	0.0000	0.0003	16.4	310.3
DG - 10 x 8 x 13	C	1750	12,836	Centerline	Dual	0.0000	0.0006	18.6	418.9
DH - 12 x 10 x 13	C	1750	12,836	Centerline	Dual	0.0001	0.0009	19.1	418.9
EA - 8 x 6 x 16	C	1750	11,527	Centerline	Dual	0.0000	0.0004	25.0	647.3
EB - 10 x 8 x 16	C	1750	12,239	Centerline	Dual	0.0000	0.0005	25.4	595.9
EC - 14 x 12 x 16	D	1750	10,113	Centerline	Dual	0.0004	0.0008	7.00	849.4
FA - 8 x 6 x 20	C	1750	10,023	Centerline	Dual	0.0000	0.0005	27.3	1232.0
FB - 10 x 8 x 20	C	1750	9,076	Centerline	Dual	0.0001	0.0007	24.8	1495.0
FC - 12 x 10 x 20	D	1750	7,435	Centerline	Dual	0.0002	0.0004	27.5	1859.0
FD - 14 x 12 x 20	D	1750	6,597	Centerline	Dual	0.0004	0.0007	29.9	2298.0

1.1 Standard Surface Treatment

All Maxums handling liquids below 230 °F are painted to Carver Standard PA-001. This provides for one coat of Carver Blue, industrial alkyd metal enamel with a 3-5 mils dry film thickness. Pumps handling liquids above 230 °F are painted to Carver Standard PA-013 with two coats modified silicone alkyd resin, aluminum colored, to a total of 2 mils dry film thickness.

Since all pumps and parts are assumed to be installed and operated soon after receipt, no special preservation for long term storage are included.

Standard Surface Preparation		
Component	Material	Specification
Adaptor bracket	Steel	Carver Standard PA-001
	316 SS	Not applicable
Base & Coupling Guard	Steel	Carver Standard PA-001
	316 SS	Not applicable
Bearing frame	Cast iron	Carver Standard PA-001
Casing	Steel	Carver Standard PA-001
	316 SS	Not applicable
Motor	Any	Carver Standard PA-001

1.2 Basic Impeller Design Features

Standard impeller design features for the Maxum are given in the table below, with speed-dependent values given for the maximum permissible speed.

Basic Impeller Features									
Basic Pump Size	<i>Type</i>	<i>Axial Thrust Back Design</i>	<i>"K" Factor</i>	<i>Eye Area (inch)²</i>	<i>No. of Vanes</i>	<i>Shut Off Head (ft)</i>	<i>Specific Speed Ns</i>	<i>Suction Sp. Speed Nss</i>	<i>Max. Solids Size (inch)</i>
AA - 1½ x 1 x 6	Enclosed	Pump out vanes	0.325	2.400	4	120	1,071	6,907	0.23
AB - 2 x 1½ x 6	Enclosed	Pump out vanes	0.375	3.750	4	160	1,337	14,044	0.31
AC - 3 x 1½ x 6	Enclosed	Pump out vanes	0.375	5.125	5	158	1,250	7,446	0.38
AD - 3 x 2 x 6	Enclosed	Pump out vanes	0.375	8.200	6	190	1,455	11,644	0.50
AE - 4 x 3 x 6	Enclosed	Wear ring	0.003	12.00	8	171	2,279	8,516	0.88
BA - 1½ x 1 x 8	Enclosed	Pump out vanes	0.260	2.070	4	270	578	5,183	0.14
BB - 2 x 1½ x 8	Enclosed	Pump out vanes	0.260	3.560	6	285	690	6,423	0.19
BC - 3 x 1½ x 8	Enclosed	Pump out vanes	0.260	5.500	5	292	807	9,761	0.25
BD - 3 x 2 x 8	Enclosed	Pump out vanes	0.260	8.000	5	285	952	7,361	0.38
BE - 4 x 3 x 8	Enclosed	Wear ring	0.003	15.80	7	290	1,746	10,135	0.75
BF - 6 x 4 x 8	Enclosed	Pump out vanes	0.260	18.00	8	290	2,111	11,683	1.13
CA - 2 x 1½ x 10	Enclosed	Wear ring	0.003	3.300	6	475	413	4,793	0.19
CB - 3 x 1½ x 10	Enclosed	Pump out vanes	0.260	5.940	5	420	413	9,939	0.30
CC - 3 x 2 x 10	Enclosed	Pump out vanes	0.260	8.600	6	470	663	7,887	0.38
CD - 4 x 3 x 10	Enclosed	Wear ring	0.003	16.00	7	465	668	11,824	0.63
CE - 6 x 4 x 10	Enclosed	Pump out vanes	0.260	21.50	7	450	1,117	11,547	0.88
CF - 6 x 6 x 10	Enclosed	Pump out vanes	0.260	24.70	5	115	1,960	7,180	1.00
CG - 8 x 6 x 10	Enclosed	Pump out vanes	0.260	39.00	6	103	2,828	10,204	1.50
DA - 2 x 1½ x 13	Enclosed	Pump out vanes	0.300	5.150	6	730	329	5,624	0.31
DB - 3 x 2 x 13	Enclosed	Wear ring	0.003	8.600	6	705	480	11,296	0.38
DC - 4 x 3 x 13	Enclosed	Wear ring	0.003	18.00	7	720	792	11,080	0.38
DD - 6 x 4 x 13	Enclosed	Pump out vanes	0.300	21.50	7	710	912	10,500	0.69
DE - 6 x 6 x 13	Enclosed	Pump out vanes	0.300	28.60	7	167	1,350	7,475	0.88
DF - 8 x 6 x 13	Enclosed	Wear ring	0.003	44.00	8	172	1,771	10,595	1.44
DG - 10 x 8 x 13	Enclosed	Wear ring	0.003	60.00	7	160	2,466	13,029	1.88
DH - 12 x 10 x 13	Enclosed	Pump out vanes	0.300	89.00	6	164	3,570	12,182	2.75
EA - 8 x 6 x 16	Enclosed	Pump out vanes	0.300	44.00	7	282	1,211	10,677	1.00
EB - 10 x 8 x 16	Enclosed	Pump out vanes	0.300	60.00	8	265	1,477	12,794	1.38
EC - 14 x 12 x 16	Enclosed	Wear ring	0.003	105.0	7	265	3,106	13,609	2.50
FA - 8 x 6 x 20	Enclosed	Pump out vanes	0.425	43.50	7	425	909	10,268	0.75
FB - 10 x 8 x 20	Enclosed	Wear ring	0.003	61.00	7	435	1,092	11,449	1.00
FC - 12 x 10 x 20	Enclosed	Wear ring	0.003	102.0	7	425	1,633	13,006	1.38
FD - 14 x 12 x 20	Enclosed	Wear ring	0.003	125.0	7	405	2,026	9,912	2.00

1.3 Inlet Pressure and Seal Arrangements

The pressure at the Maxum stuffing box can be approximated from the following equation once the suction and discharge pressures are known:

$$P_{\text{stuffing box}} = P_{\text{suction}} + \{K \times (P_{\text{discharge}} - P_{\text{suction}})\}$$

where.....

- $P_{\text{stuffing box}}$ = pressure in stuffing box (PSI)
- P_{suction} = pump inlet pressure (PSI)
- K = dimensionless pressure reduction factor (see table above)
- $P_{\text{discharge}}$ = pump discharge pressure (PSI)

For applications with stuffing box pressures in excess of 150 PSI a balanced seal is recommended. Likewise, for applications with stuffing box pressures below 50 PSI, an unbalanced seal is recommended.

1.4 Standard Materials

The standard Maxum materials, and their corresponding material specifications for the major components, are given in the table below:

Standard Materials – by API Material Code				
Component	S-1	S-8	A-8	D-1
Bearing frame	Carbon steel ASTM A216 Grade WCB	Carbon steel ASTM A216 Grade WCB	Carbon steel ASTM A216 Grade WCB	Carbon steel ASTM A216 Grade WCB
Casing	Carbon steel ASTM A216 Grade WCB	Carbon steel ASTM A216 Grade WCB	316 Stainless steel ASTM A744 Grade CF-8M	Duplex stainless steel ASTM A890 Grade1A, CD4MCu
Backhead	Carbon steel ASTM A216 Grade WCB	Carbon steel ASTM A216 Grade WCB	316 Stainless steel ASTM A744 Grade CF-8M	Duplex stainless steel ASTM A890 Grade1A, CD4MCu
Impeller	Ductile iron ASTM A536 Grade 65-45-12	316 Stainless steel ASTM A744 Grade CF-8M	316 Stainless steel ASTM A744 Grade CF-8M	Duplex stainless steel ASTM A890 Grade1A, CD4MCu
Wear rings	Ductile iron ASTM A536 Grade 65-45-12	Stainless steel 17-4 PH UNS No. J92180	Stainless steel 17-4 PH UNS No J92180	Duplex stainless steel 17-4 PH UNS No. J92180
Shaft	Steel AISI 4140 UNS No. G41400	316 Stainless steel ASTM A276 UNS 31600	316 Stainless steel ASTM A276 UNS 31600	316 Stainless steel ASTM A890 Grade1A, CD4MCu

1.5 Key Mechanical Data

Many of the key Maxum mechanical design specifications and parameters are as follows:

Key Mechanical Data				
Item	Bearing Frame			
	<i>A</i>	<i>B</i>	<i>C</i>	<i>D</i>
Max power (BHP) @ 3500 RPM	150	240	550	-
@ 1750 RPM	75	120	275	1500
@ 1150 RPM	50	80	180	1000
Bearing type - radial bearing	6208	6211	6213	6219
thrust bearing	7308	7311	7313	7318
Lubrication method (standard)	Oil - ISO Grade 68			
L ₁₀ bearing life (hrs) - radial	50,000			
thrust	50,000			
Radial to thrust bearing centerline (in.)	5.98	5.98	8.92	13.19
Shaft diameter (in.) @ coupling	1.125	1.375	2.000	3.000
@ impeller hub (std. extension)	1.000	1.375	1.875	2.375
@ radial bearing	1.575	2.166	2.559	3.741
@ thrust bearing	1.575	2.166	2.559	3.544
under shaft sleeve	1.500	2.000	2.500	3.50
Coupling Key - width (in.)	0.250	0.313	0.500	0.750
length (in.)	2.000	2.000	2.000	5.000

1.6 Basic Structural Design Limits

Standard structural design features are given in the table below. Note that all casing pressure and inlet (suction) pressure values are given at an assumed worst case of 650 °F, and all maximum inlet pressure values are given at an assumed worst case of maximum (i.e., untrimmed) impeller diameter.

Basic Structural Design Limits									
Pump Size	Max. Casing Pressure (PSI)			Max. Inlet Pressure (PSI)			Min. Case Thickness (in.)	Wear Ring Clearance	
	<i>Steel</i>	<i>316 SS</i>	<i>CD4MCu</i>	<i>Steel</i>	<i>316 SS</i>	<i>CD4MCu</i>		<i>Front (in)</i>	<i>Back (in)</i>
AA - 1½ x 1 x 6	766	613	985	714	561	933	0.469	0.012	n/a
AB - 2 x 1½ x 6	652	522	838	583	452	769	0.500	0.015	n/a
AC - 3 x 1½ x 6	554	443	712	486	375	644	0.500	0.014	n/a
AD - 3 x 2 x 6	567	454	729	485	371	647	0.500	0.016	n/a
AE - 4 x 3 x 6	401	321	516	327	247	442	0.500	0.016	0.016
BA - 1½ x 1 x 8	550	440	707	433	323	590	0.540	0.012	n/a
BB - 2 x 1½ x 8	543	434	698	420	311	575	0.550	0.012	n/a
BC - 3 x 1½ x 8	401	321	516	275	194	389	0.500	0.014	n/a
BD - 3 x 2 x 8	381	305	490	258	181	366	0.500	0.016	n/a
BE - 4 x 3 x 8	345	276	444	219	150	318	0.500	0.017	0.017
BF - 6 x 4 x 8	539	431	693	413	306	567	0.670	0.017	n/a
CA - 2 x 1½ x 10	460	368	591	254	162	386	0.563	0.012	0.016
CB - 3 x 1½ x 10	467	374	600	285	192	419	0.590	0.015	n/a
CC - 3 x 2 x 10	360	288	463	157	85	259	0.562	0.016	n/a
CD - 4 x 3 x 10	406	325	522	205	124	321	0.670	0.017	0.017
CE - 6 x 4 x 10	517	414	665	322	219	470	0.750	0.018	n/a
CF - 6 x 6 x 10	419	335	539	369	285	489	0.750	0.018	n/a
CG - 8 x 6 x 10	344	275	442	299	231	398	0.750	0.019	n/a
DA - 2 x 1½ x 13	307	246	395	103	19	223	0.562	0.016	n/a
DB - 3 x 2 x 13	336	269	432	160	67	293	0.625	0.016	0.016
DC - 4 x 3 x 13	419	335	539	264	149	428	0.750	0.017	0.017
DD - 6 x 4 x 13	412	330	530	263	149	425	0.750	0.018	n/a
DE - 6 x 6 x 13	346	277	445	274	204	373	0.750	0.018	n/a
DF - 8 x 6 x 13	354	283	455	280	209	381	0.750	0.020	0.020
DG - 10 x 8 x 13	375	300	482	306	231	413	0.875	0.021	0.021
DH - 12 x 10 x 13	364	291	468	293	220	397	1.000	0.023	n/a
EA - 8 x 6 x 16	259	207	333	137	85	211	0.750	0.020	n/a
EB - 10 x 8 x 16	383	306	492	268	192	378	1.000	0.021	n/a
EC - 14 x 12 x 16	194	155	249	79	40	135	1.125	0.024	0.024
FA - 8 x 6 x 20	363	290	467	179	106	283	1.125	0.020	n/a
FB - 10 x 8 x 20	351	281	451	163	92	263	1.125	0.021	0.021
FC - 12 x 10 x 20	257	206	330	73	22	146	1.000	0.023	0.023
FD - 14 x 12 x 20	554	443	712	379	268	537	1.500	0.025	0.025

1.7 Bearing and Seal Arrangements

The standard Maxum uses single row, duplex, 40° angular contact ball bearings to handle axial thrust loads and a single row, Conrad type bearing for the radial loads.

Both are oil lubricated for more effective lubricant penetration of the bearing internals. The bearings can also be provided with several different lubrication arrangements, including external water cooling for higher temperature applications.

Bearing and Seal Temperature Limits			
Bearing	Cooling	Min	Max
Oil Lube	Air	-20° F	299° F
	1 GPM water flush	300° F	349° F
	2 GPM water flush	350° F	410° F
	3 GPM water flush	411° F	500° F

In the table a cooling water temperature of 60° F is assumed. These temperatures limits must be observed to avoid adversely effecting pump life, permanently degrading the fluid, bringing the pump out of alignment, and/or seizing the pump.

The Maxum warranty is also based on strict adherence to these limits.

1.8 Comments, Clarifications and/or Exceptions to API Standard 610, 8th Edition

Section 1 – General

None

Section 2 – Basic Design

2.1.18 (Cooling jacket cleaning and flushing) – Clarification

The cooling jackets, when provided, must be drained and flushed through the cooling jacket inlet and outlet connections. The jackets must be removed for further cleaning.

2.2.9 (Centerline mounting) – Comment

Standard Maxum mounting is foot mounted. Centerline mounting can be provided if specified.

2.3.1.2 (Drain, gauge and vent connections) – Comment

Standard Maxum drain, gauge and vent connection sizes are either ½ inch NPT or ¾ inch NPT, depending on the pump size. ¾ inch NPT drain, gauge and vent sizes can be provided on any size Maxum if specified.

2.6.1 (Pump out vanes for axial balance) – Comment

The standard Maxum means for handling axial thrust loads is either with impeller pump out vanes or replaceable rear wear rings, depending on the pump size. Replaceable rear wear rings in lieu of pump out vanes can be provided on any size Maxum if specified.

2.7.3.6 (Stuffing box dimensions) – Exception

The standard Maxum stuffing box dimensions that do not fully conform to dimensions listed. This is done to offer as short a rotor assembly as possible, with the resulting shaft deflection never exceeding 0.001 inch at the seal when operating at the point representing 20% of BEP. This maximum shaft deflection is less than half the deflection allowed in Paragraph 2.5.7. The stuffing boxes and seals do, however, meet the required 1/8 inch radial clearance required.

2.9.1.3 (Bearings on shaft) – Comment

The standard Maxum bearings are fitted on the shaft with clearances per ANSI / ABMA Standard 7, Tolerance j6. Tighter bearing fits, such as per ANSI / ABMA Standard 7, Tolerance k5 can be provided if specified.

Section 3 – Accessories

None

Section 4 – Inspection, Testing and Preparation for Shipment

None

Section 5 – Specific Pump Types

None

Section 6 – Vendor Data

None

1.9 Maxum Hydraulic Coverage

Maxum hydraulic performance extends to 9,500 GPM and 720 feet of head. This range is covered by thirty-three sizes in steel, 316 SS fitted steel, 316 stainless steel and CD4MCu construction.

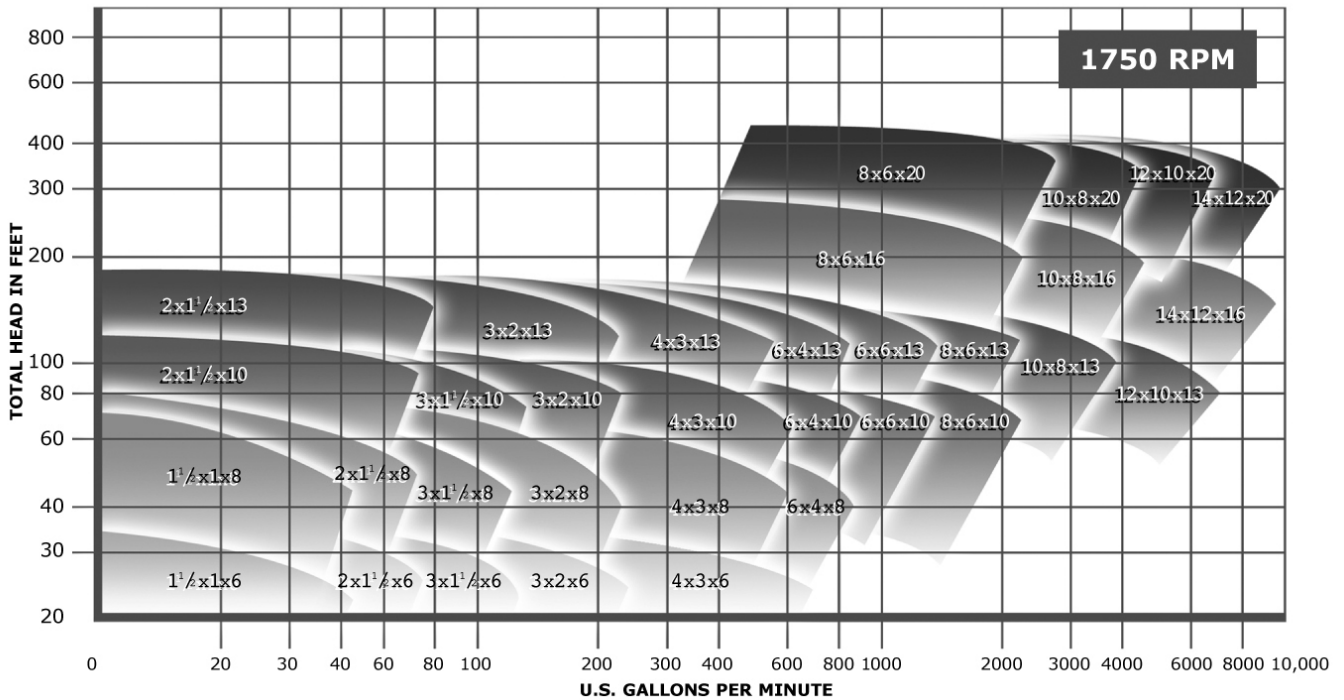
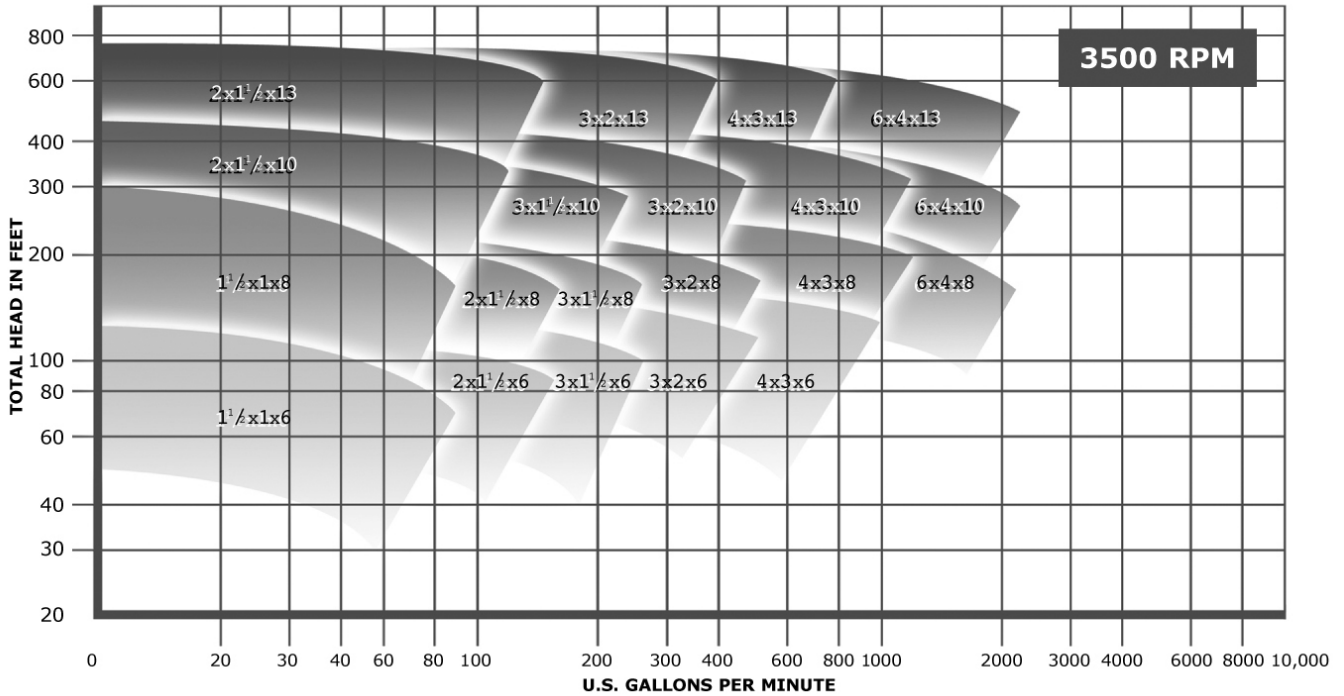

Other sizes and allowable speeds may also be possible. Contact Carver Sales and Marketing department.

Hydraulic Performance – 6" Impeller Pumps

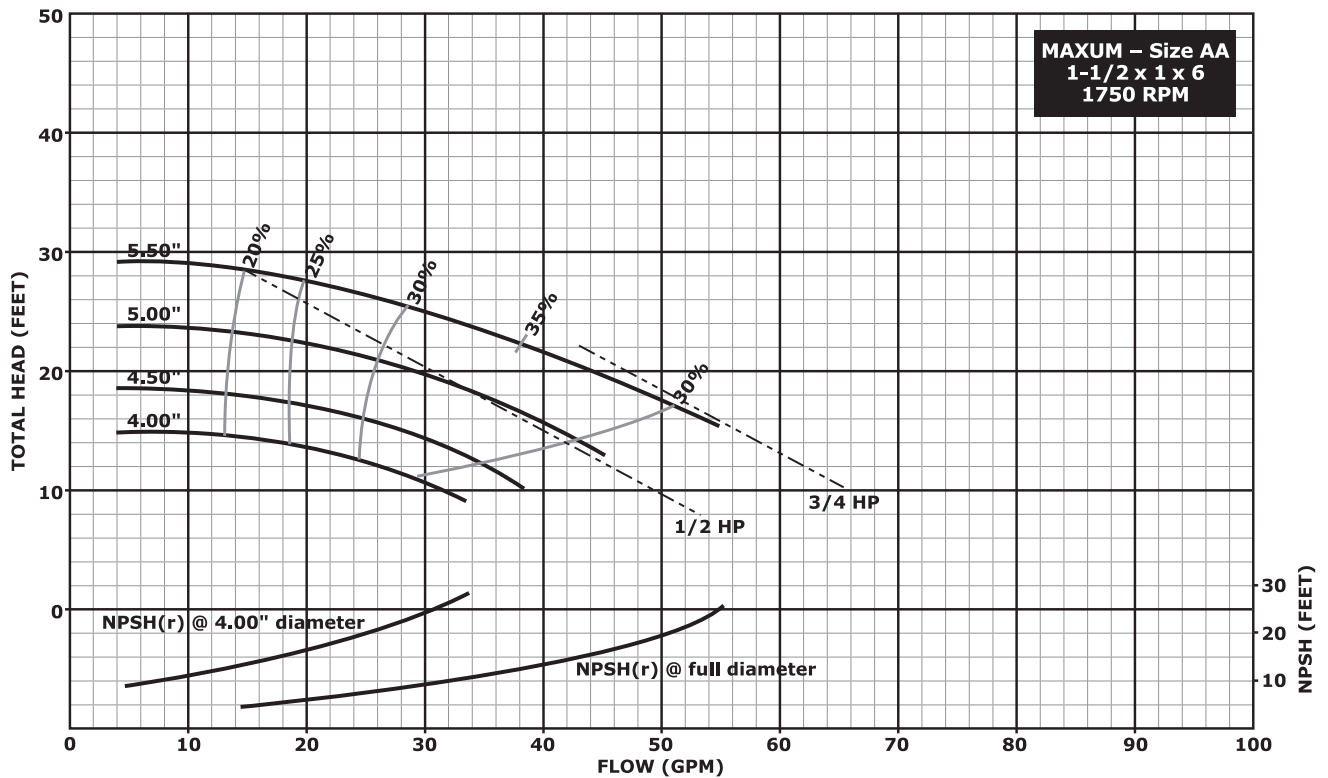
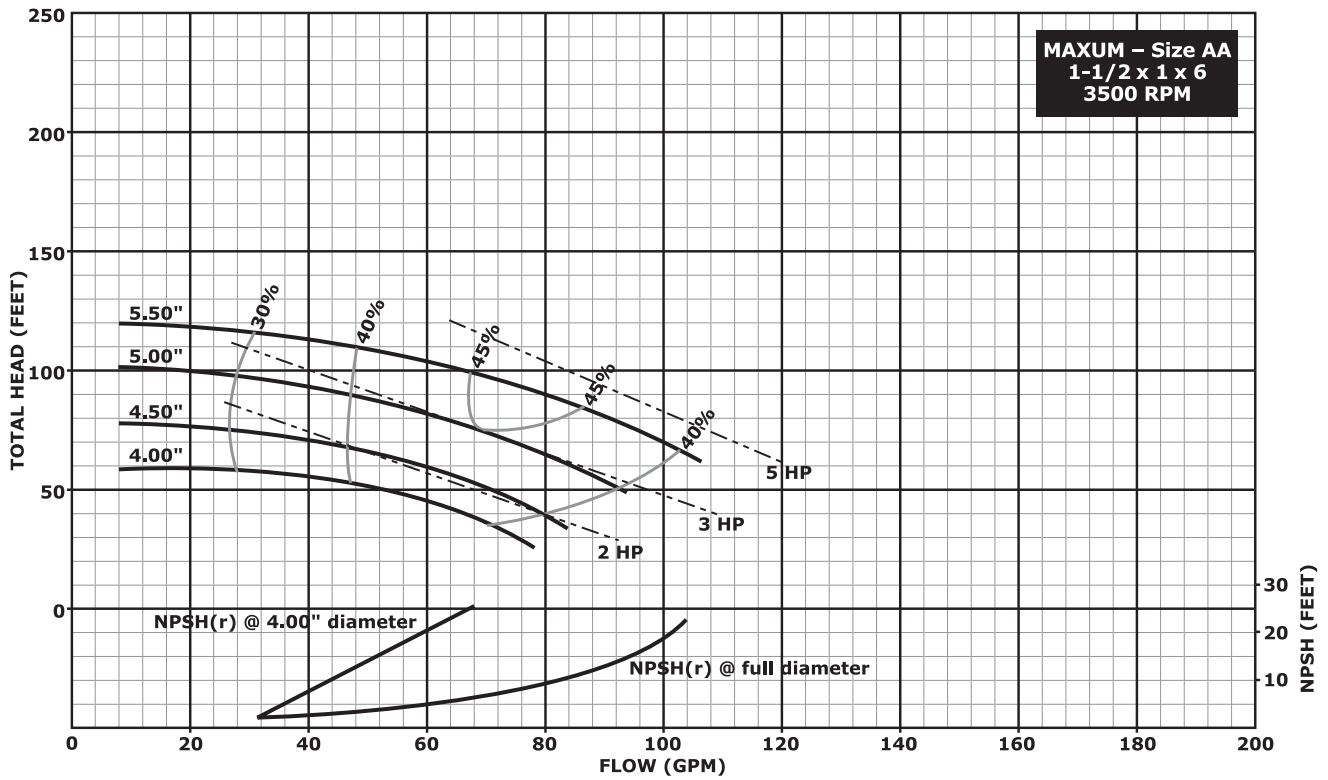

Notes:

1. Above data is based on 1.0 sp. gr. water at ambient temperature and pressure in accordance with Hydraulic Institute guidelines.
2. Impeller diameters between minimum and maximum shown are available in 1/8 inch increment trims.

Hydraulic Performance – 6" Impeller Pumps

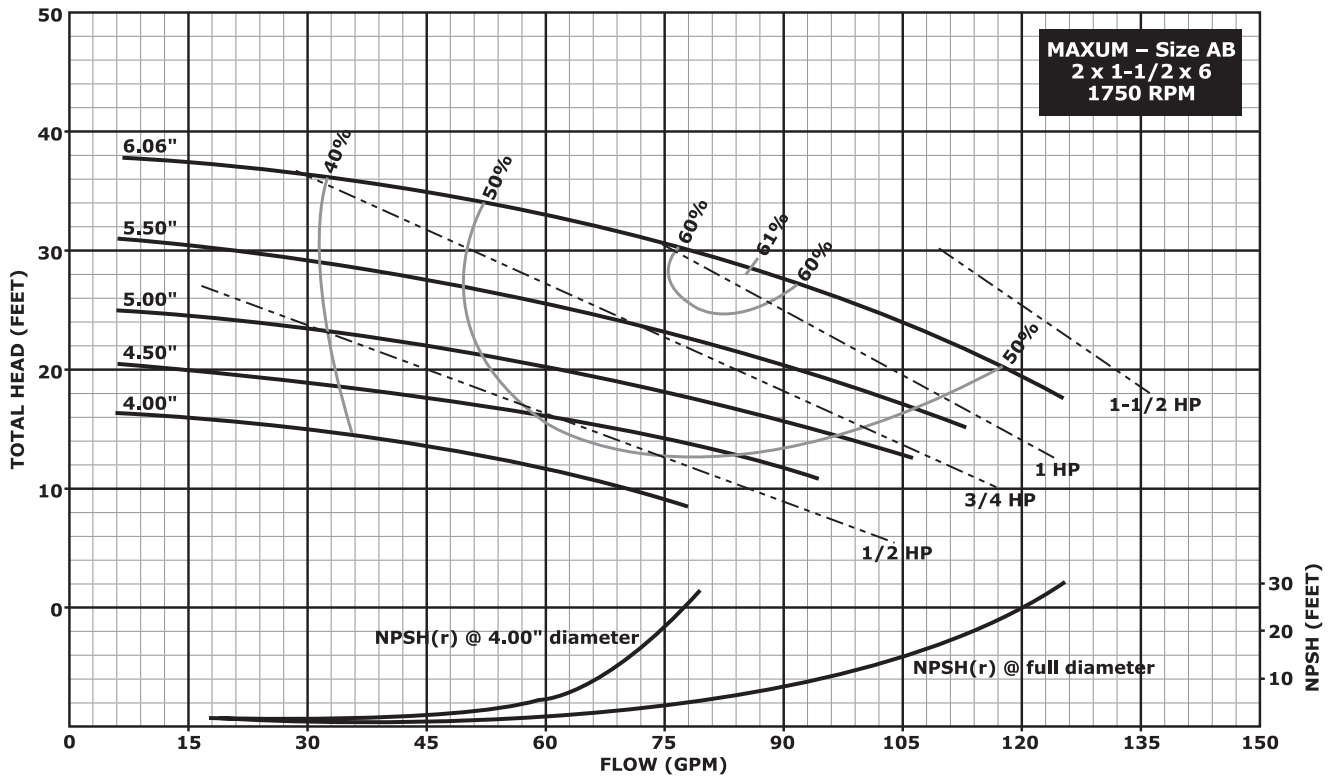
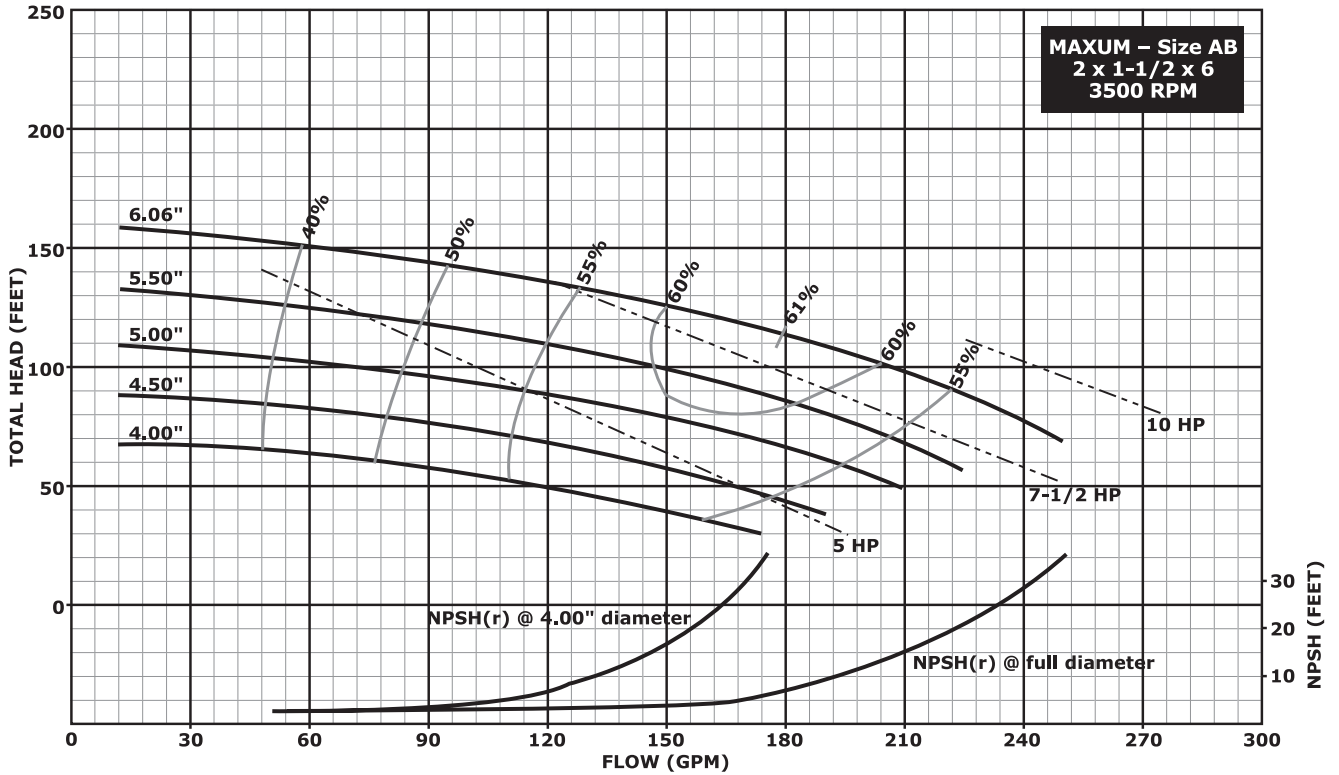

Notes:

1. Above data is based on 1.0 sp. gr. water at ambient temperature and pressure in accordance with Hydraulic Institute guidelines.
2. Impeller diameters between minimum and maximum shown are available in 1/8 inch increment trims.

Hydraulic Performance – 6" Impeller Pumps

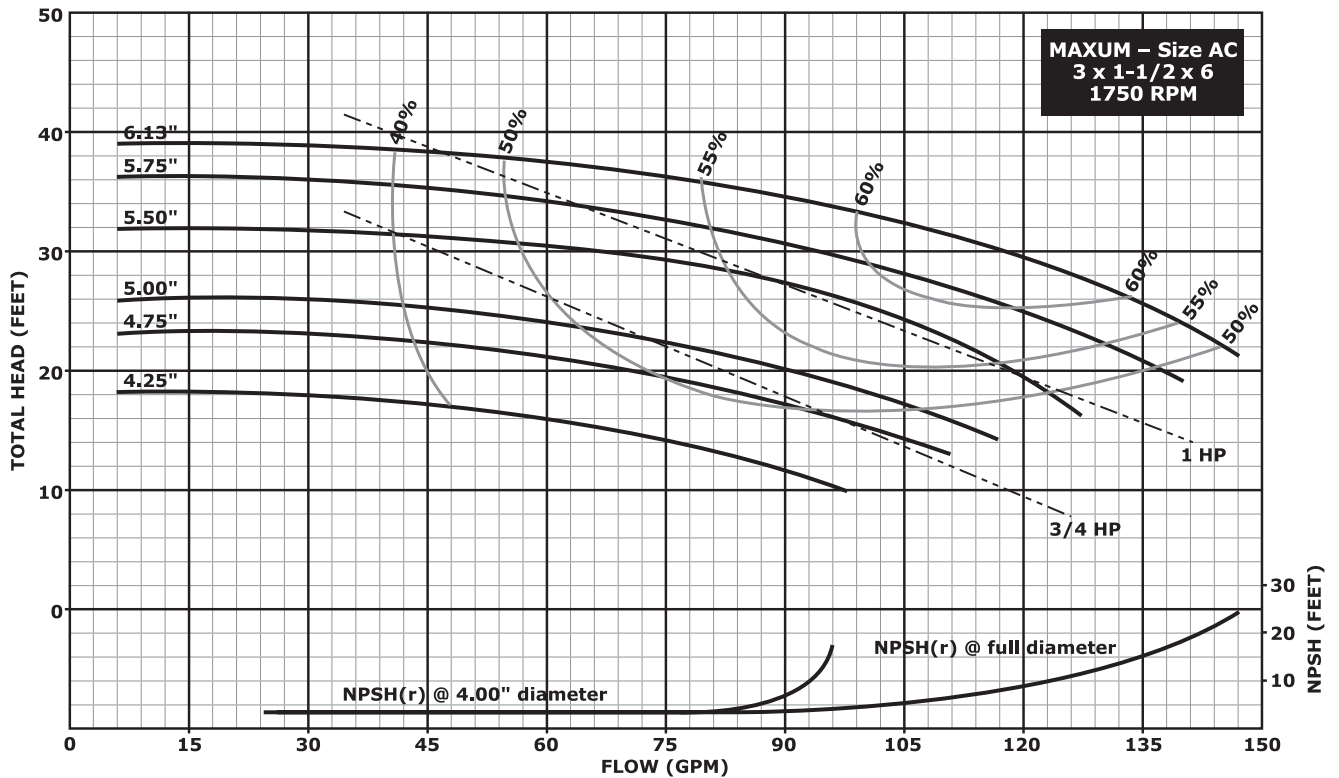
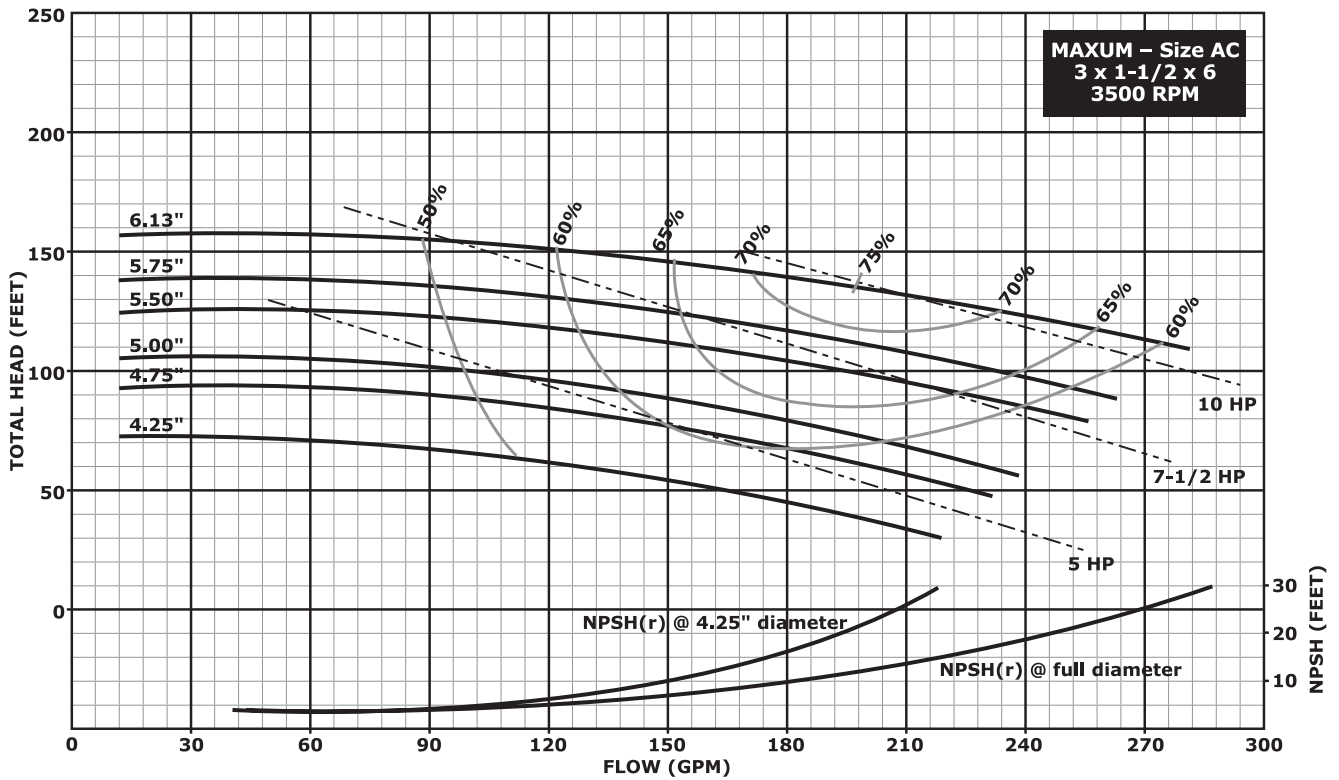

Notes:

1. Above data is based on 1.0 sp. gr. water at ambient temperature and pressure in accordance with Hydraulic Institute guidelines.
2. Impeller diameters between minimum and maximum shown are available in 1/8 inch increment trims.

Hydraulic Performance – 6" Impeller Pumps

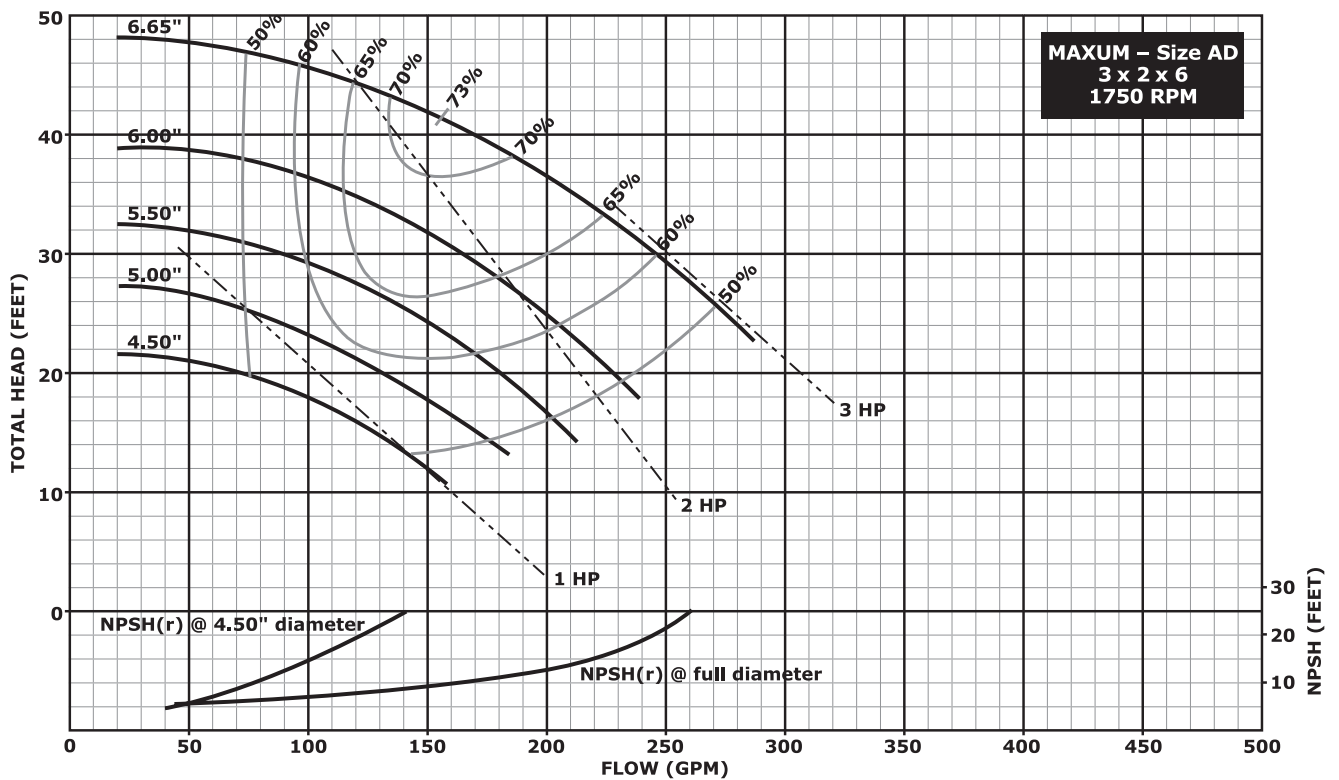
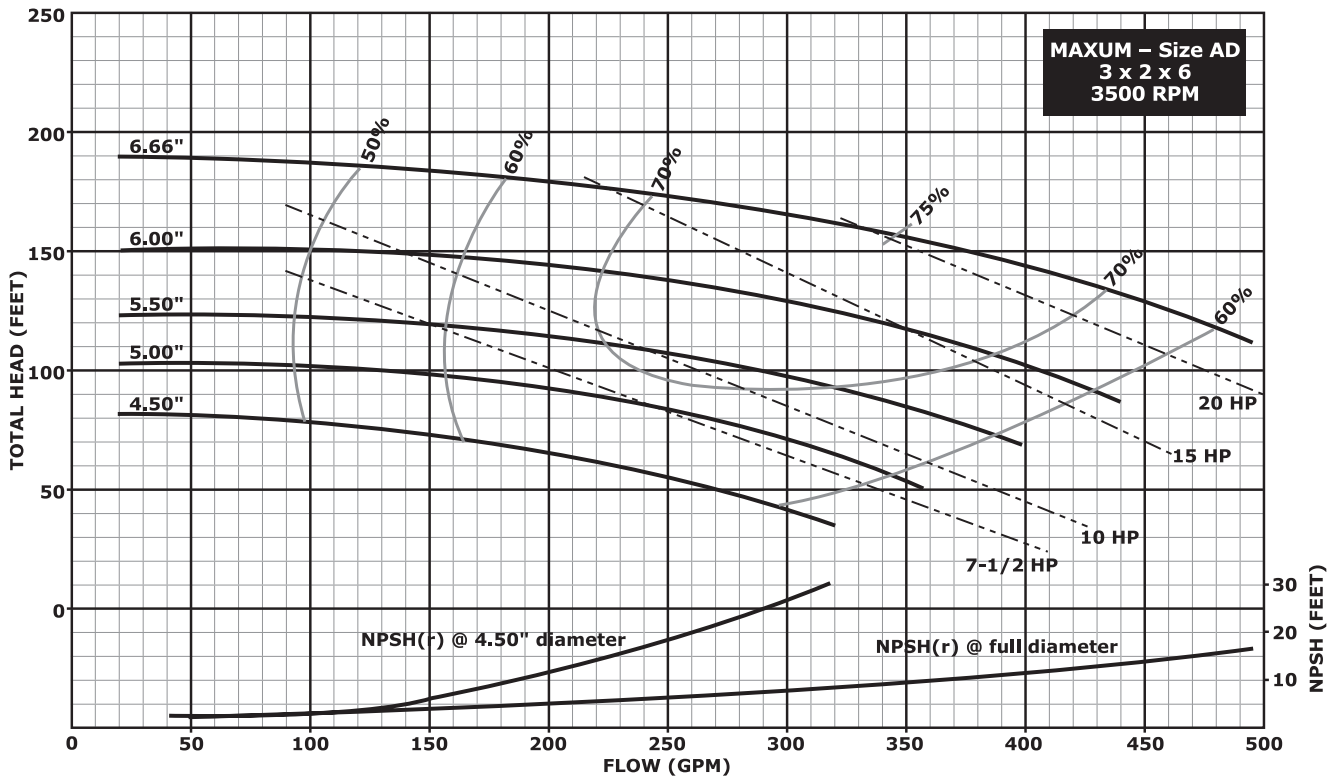

Notes:

1. Above data is based on 1.0 sp. gr. water at ambient temperature and pressure in accordance with Hydraulic Institute guidelines.
2. Impeller diameters between minimum and maximum shown are available in 1/8 inch increment trims.

Hydraulic Performance – 6" Impeller Pumps

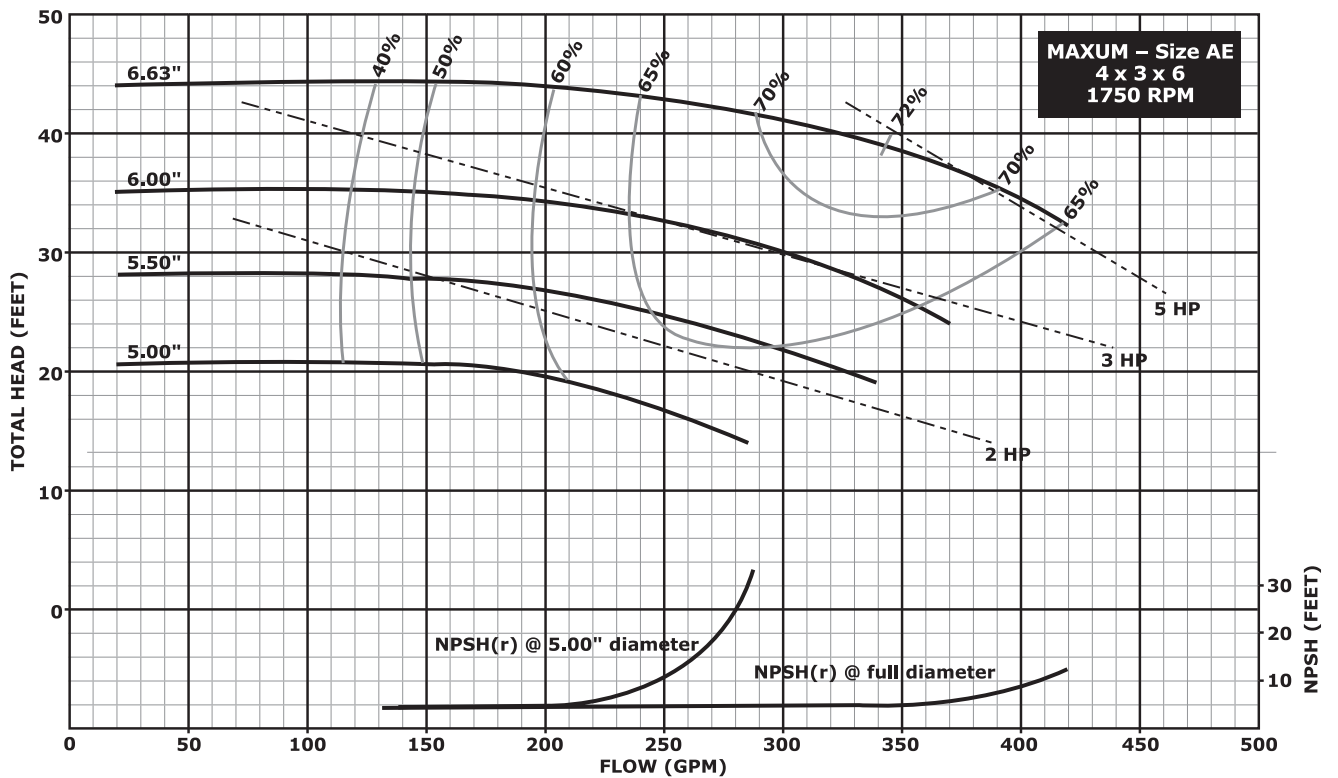
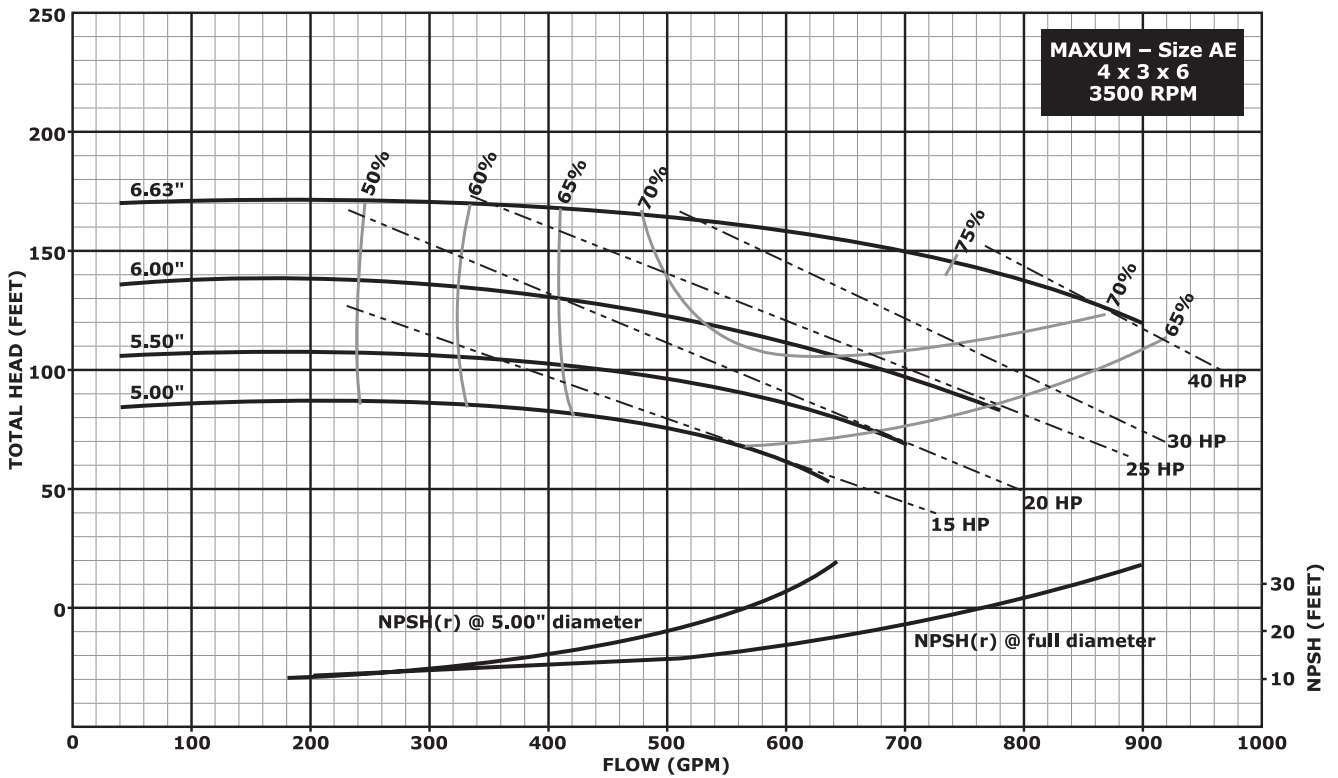

Notes:

1. Above data is based on 1.0 sp. gr. water at ambient temperature and pressure in accordance with Hydraulic Institute guidelines.
2. Impeller diameters between minimum and maximum shown are available in 1/8 inch increment trims.

Hydraulic Performance – 8" Impeller Pumps

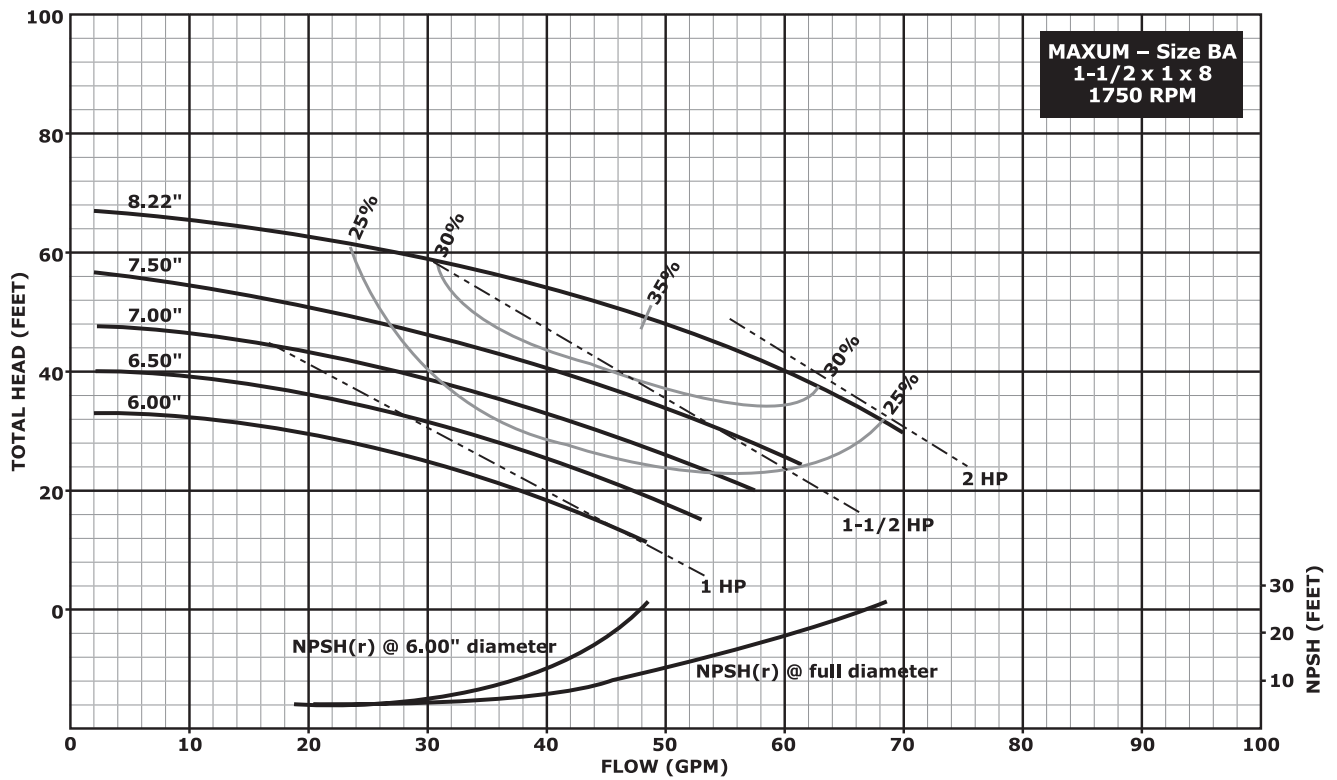
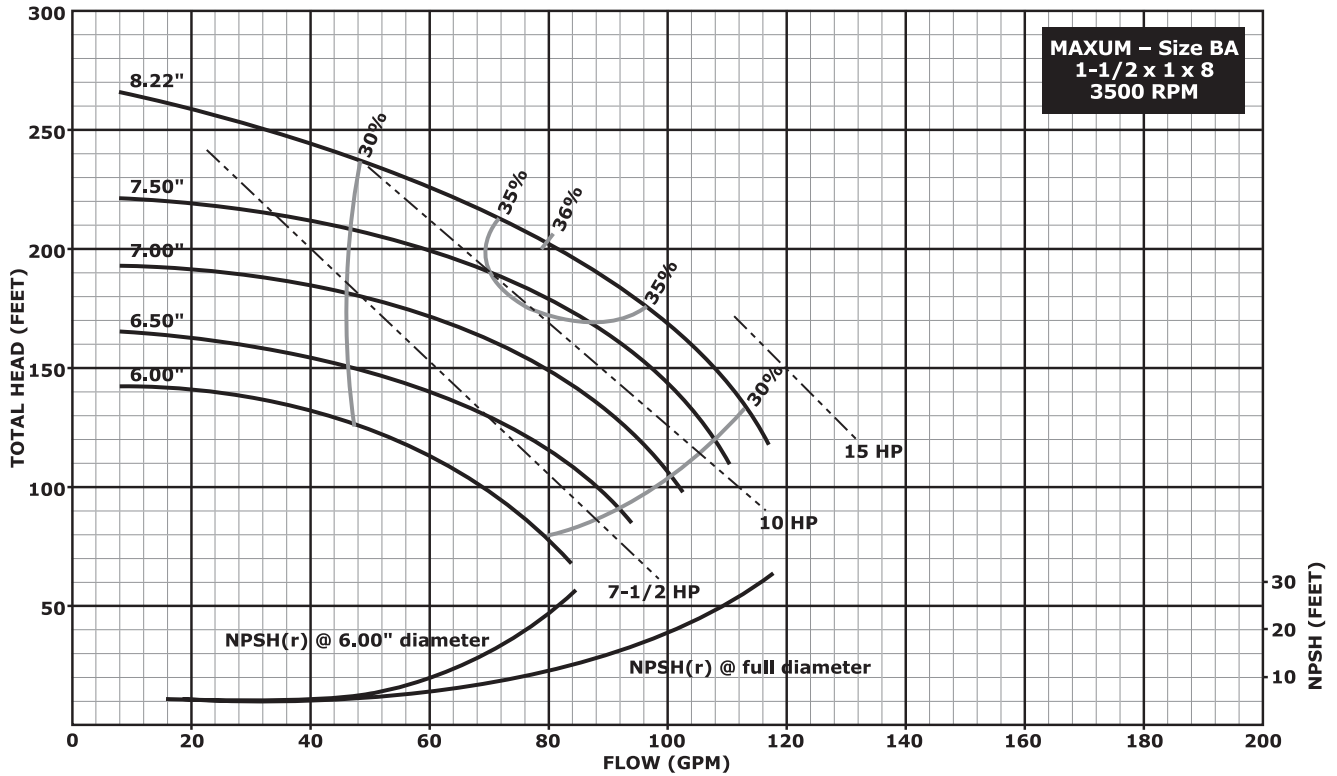

Notes:

1. Above data is based on 1.0 sp. gr. water at ambient temperature and pressure in accordance with Hydraulic Institute guidelines.
2. Impeller diameters between minimum and maximum shown are available in 1/8 inch increment trims.

Hydraulic Performance – 8" Impeller Pumps

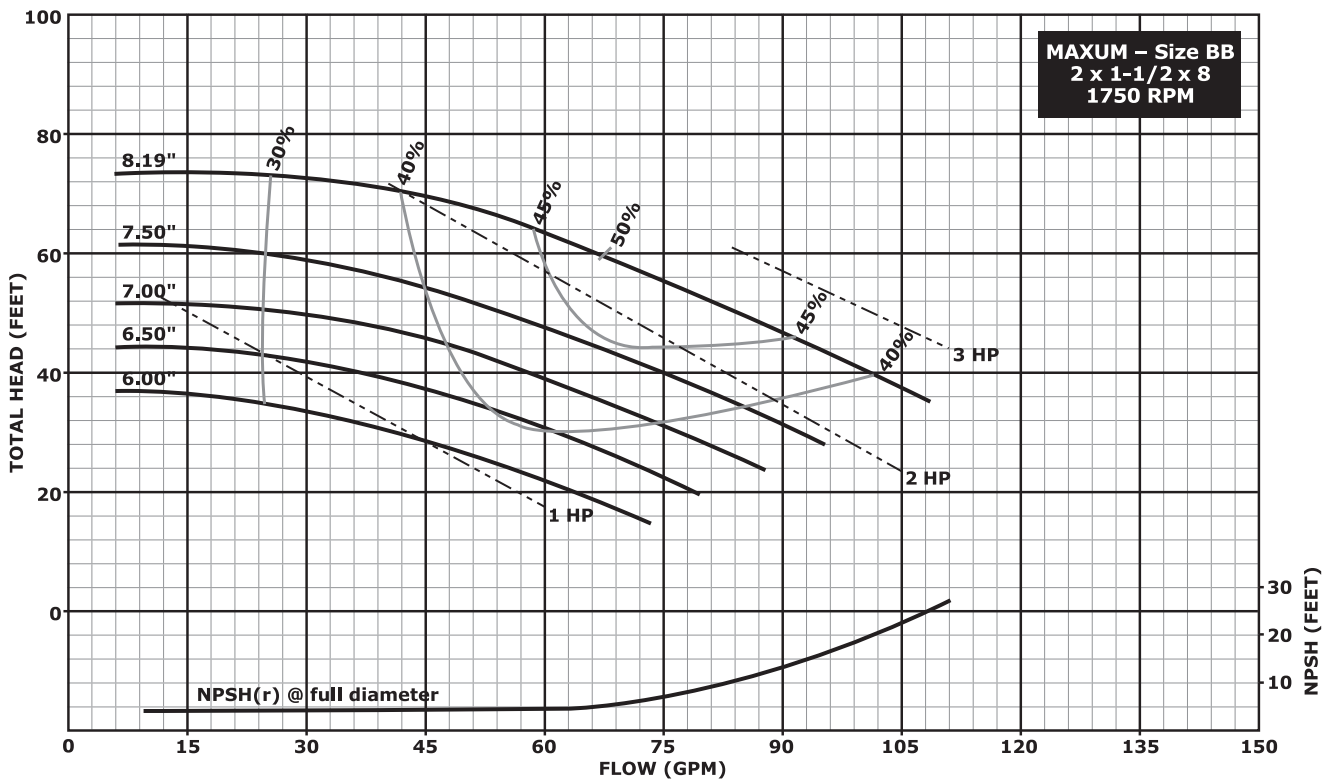
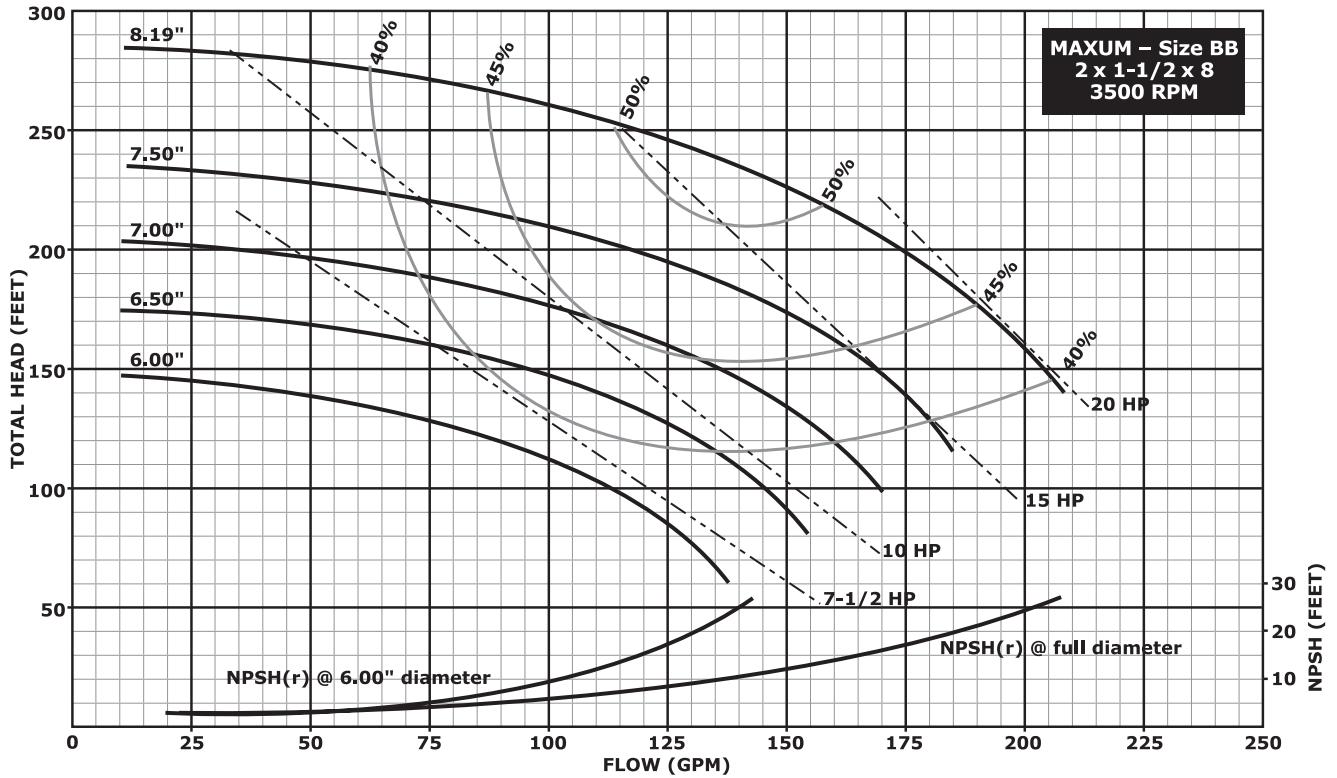

Notes:

1. Above data is based on 1.0 sp. gr. water at ambient temperature and pressure in accordance with Hydraulic Institute guidelines.
2. Impeller diameters between minimum and maximum shown are available in 1/8 inch increment trims.

Hydraulic Performance – 8" Impeller Pumps

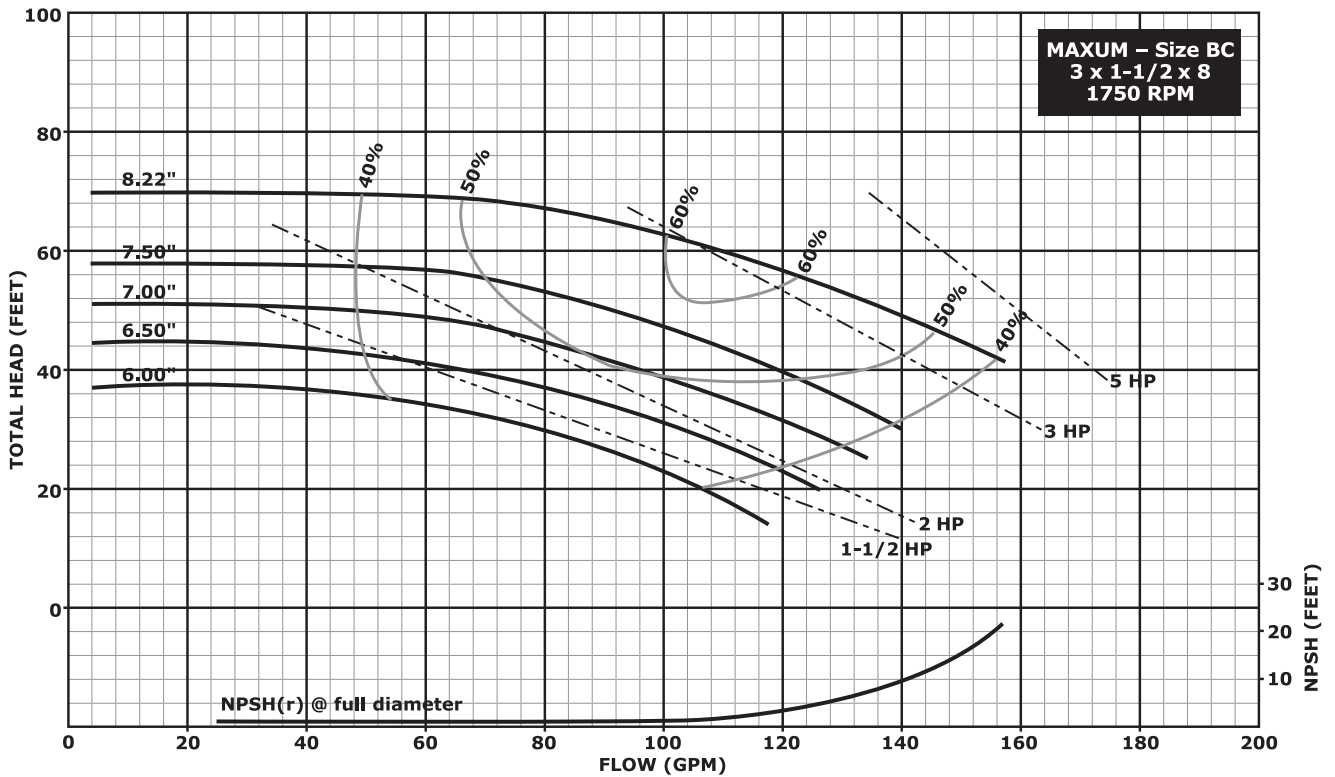
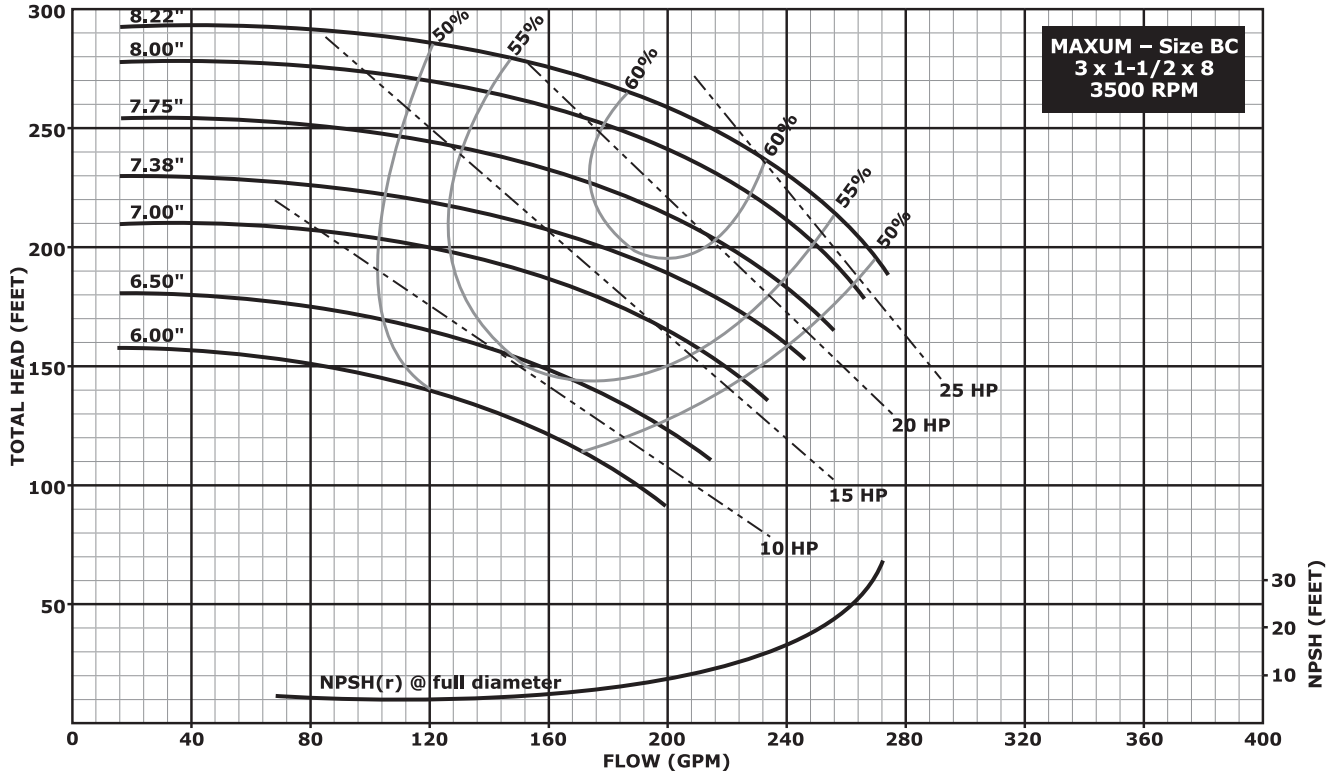

Notes:

1. Above data is based on 1.0 sp. gr. water at ambient temperature and pressure in accordance with Hydraulic Institute guidelines.
2. Impeller diameters between minimum and maximum shown are available in 1/8 inch increment trims.

Hydraulic Performance – 8" Impeller Pumps

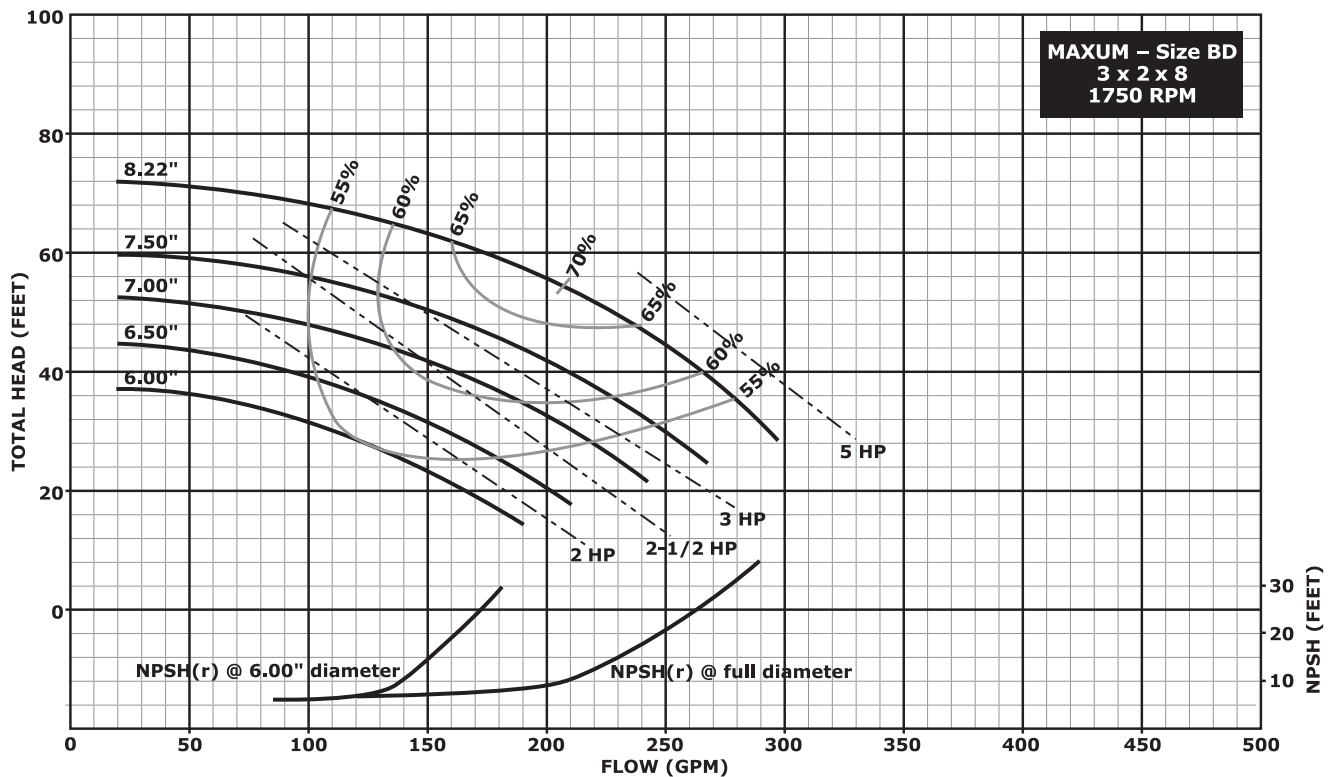
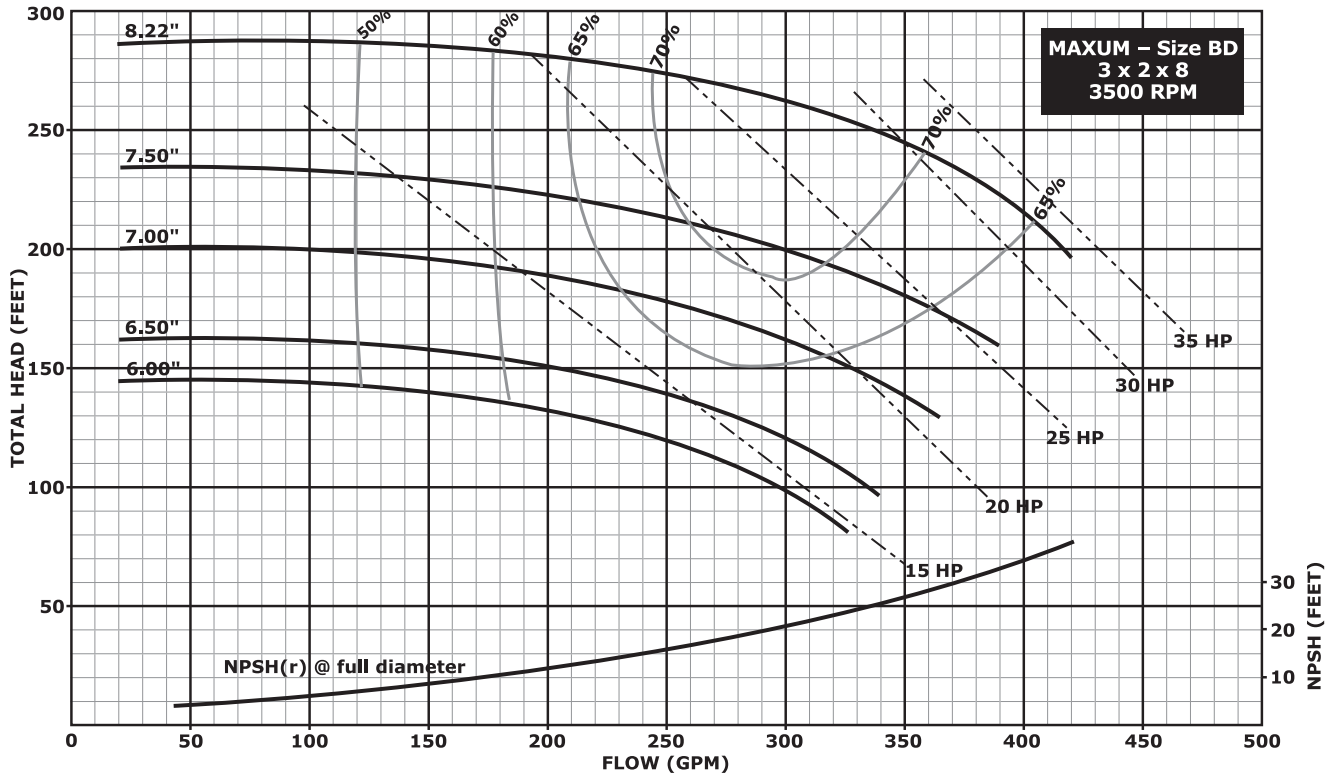

Notes:

1. Above data is based on 1.0 sp. gr. water at ambient temperature and pressure in accordance with Hydraulic Institute guidelines.
2. Impeller diameters between minimum and maximum shown are available in 1/8 inch increment trims.

Hydraulic Performance – 8" Impeller Pumps

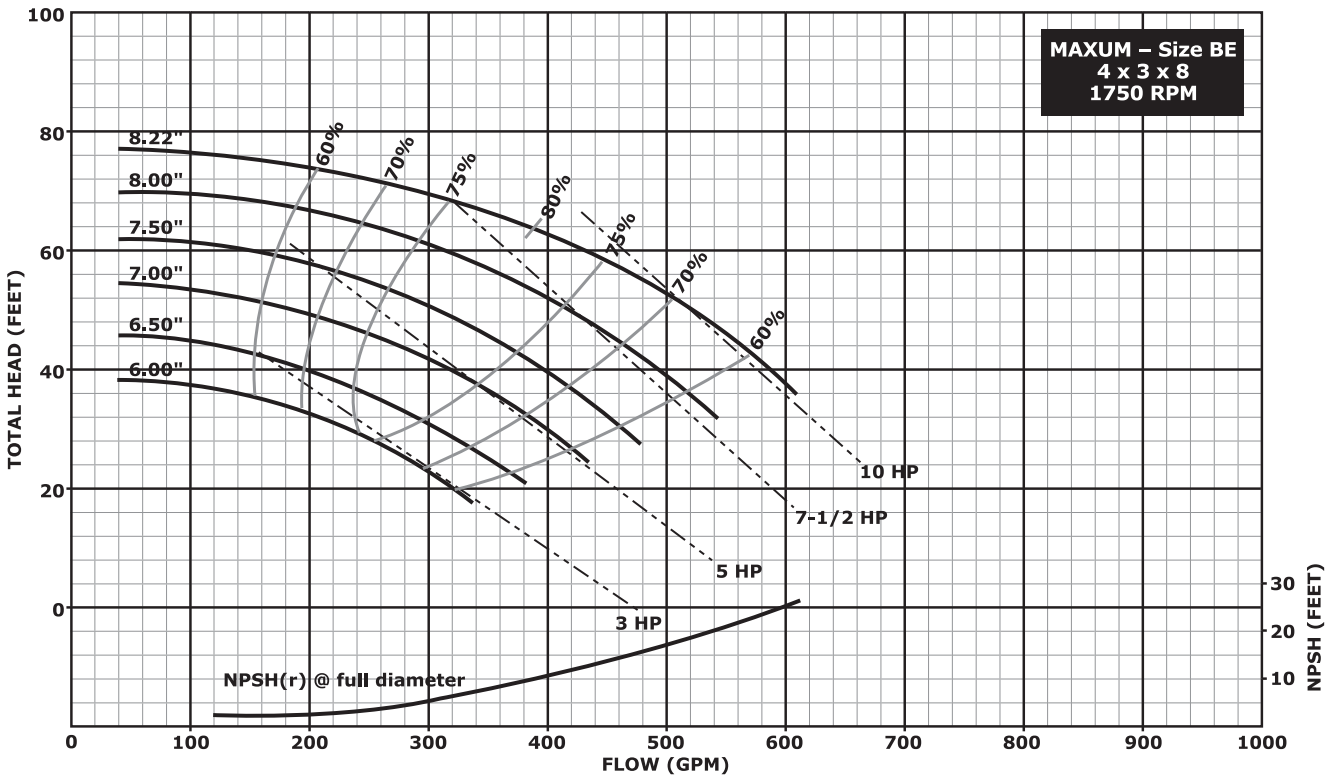
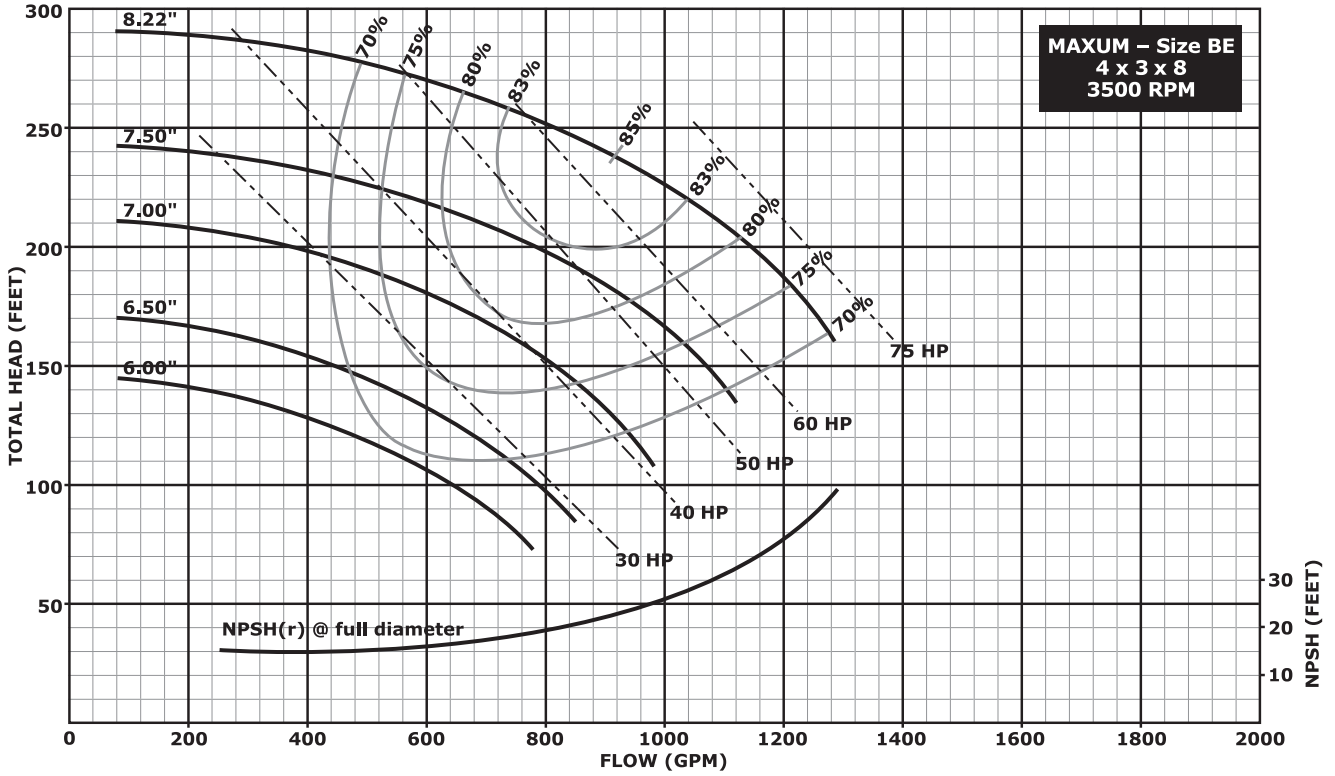

Notes:

1. Above data is based on 1.0 sp. gr. water at ambient temperature and pressure in accordance with Hydraulic Institute guidelines.
2. Impeller diameters between minimum and maximum shown are available in 1/8 inch increment trims.

Hydraulic Performance – 8" Impeller Pumps

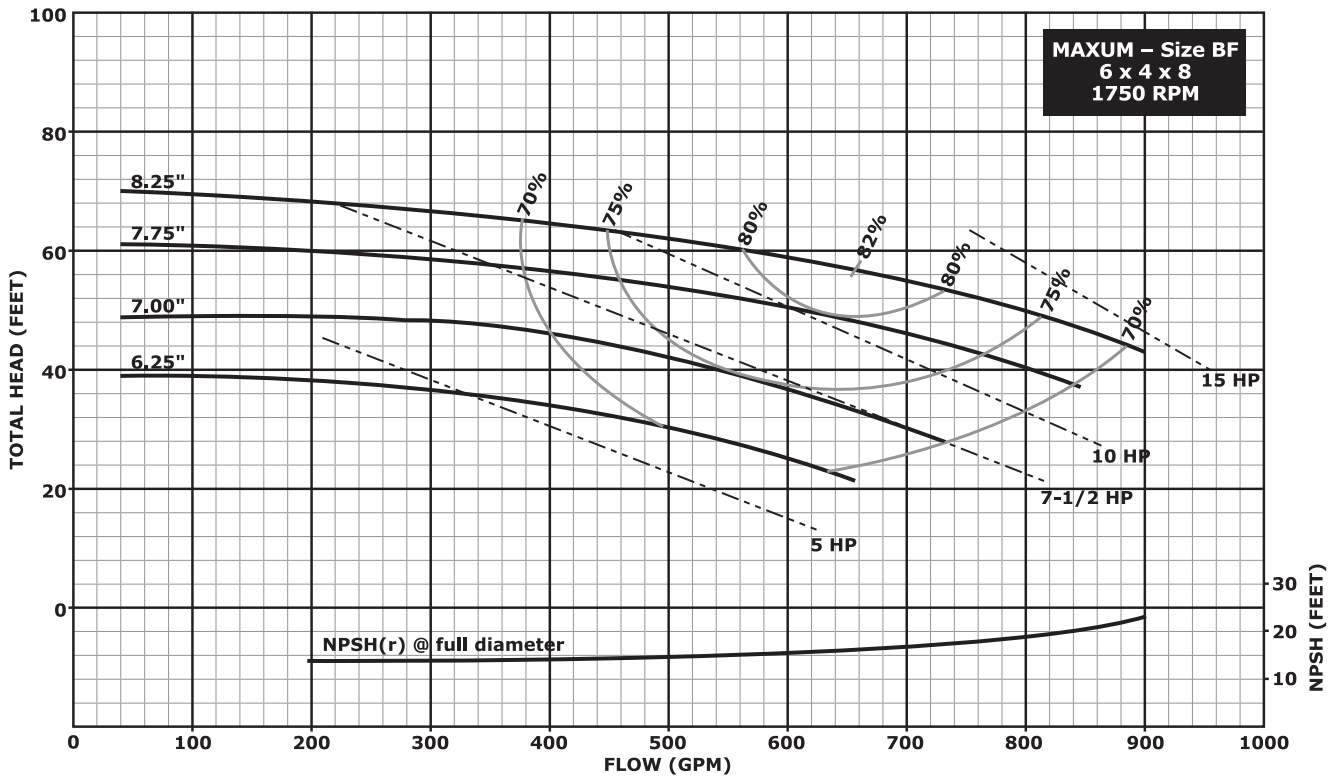
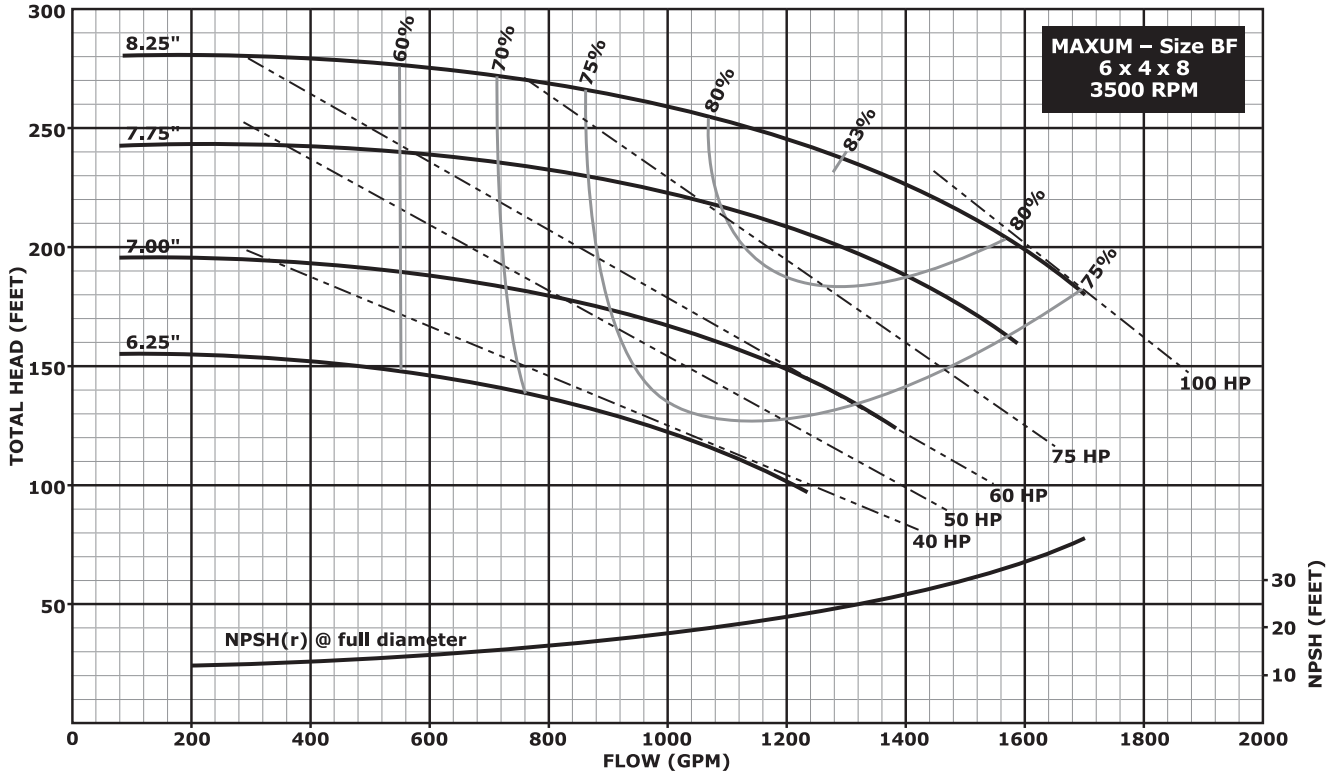

Notes:

1. Above data is based on 1.0 sp. gr. water at ambient temperature and pressure in accordance with Hydraulic Institute guidelines.
2. Impeller diameters between minimum and maximum shown are available in 1/8 inch increment trims.

Hydraulic Performance – 10" Impeller Pumps

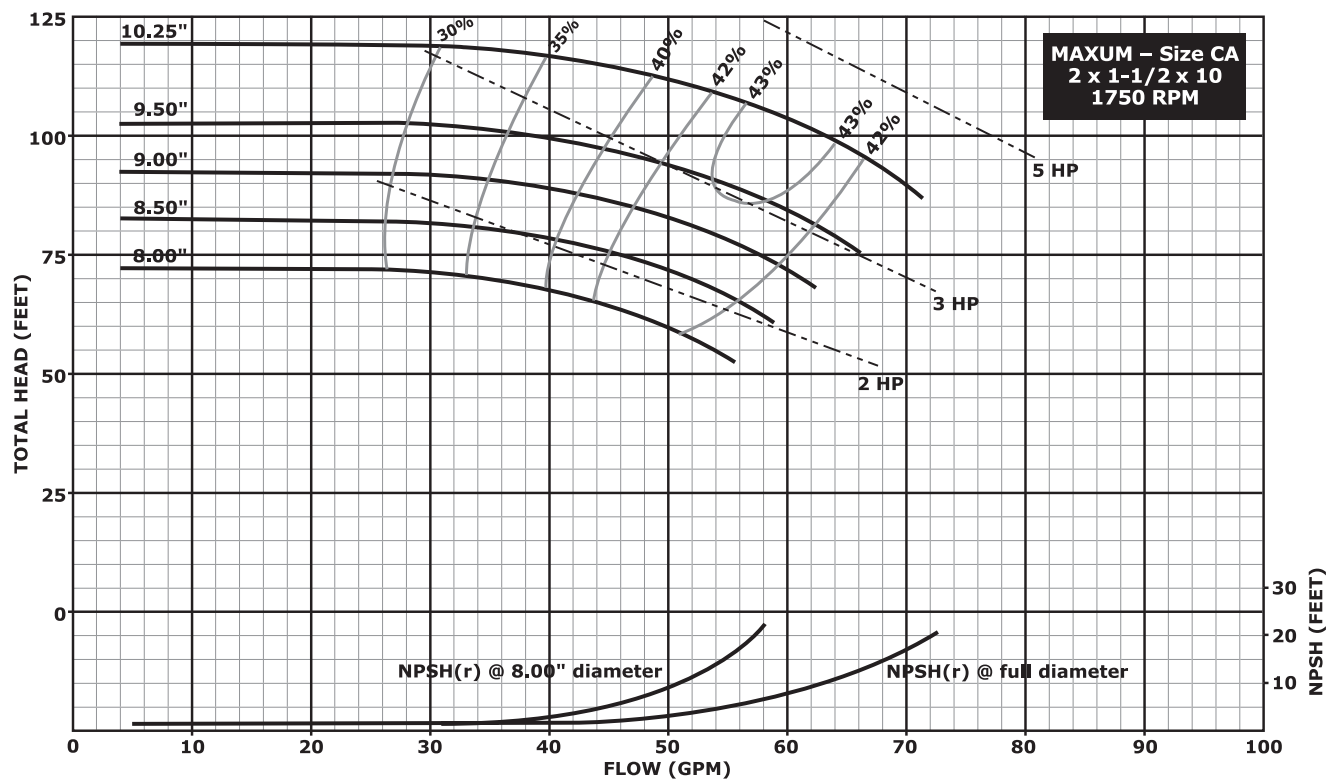
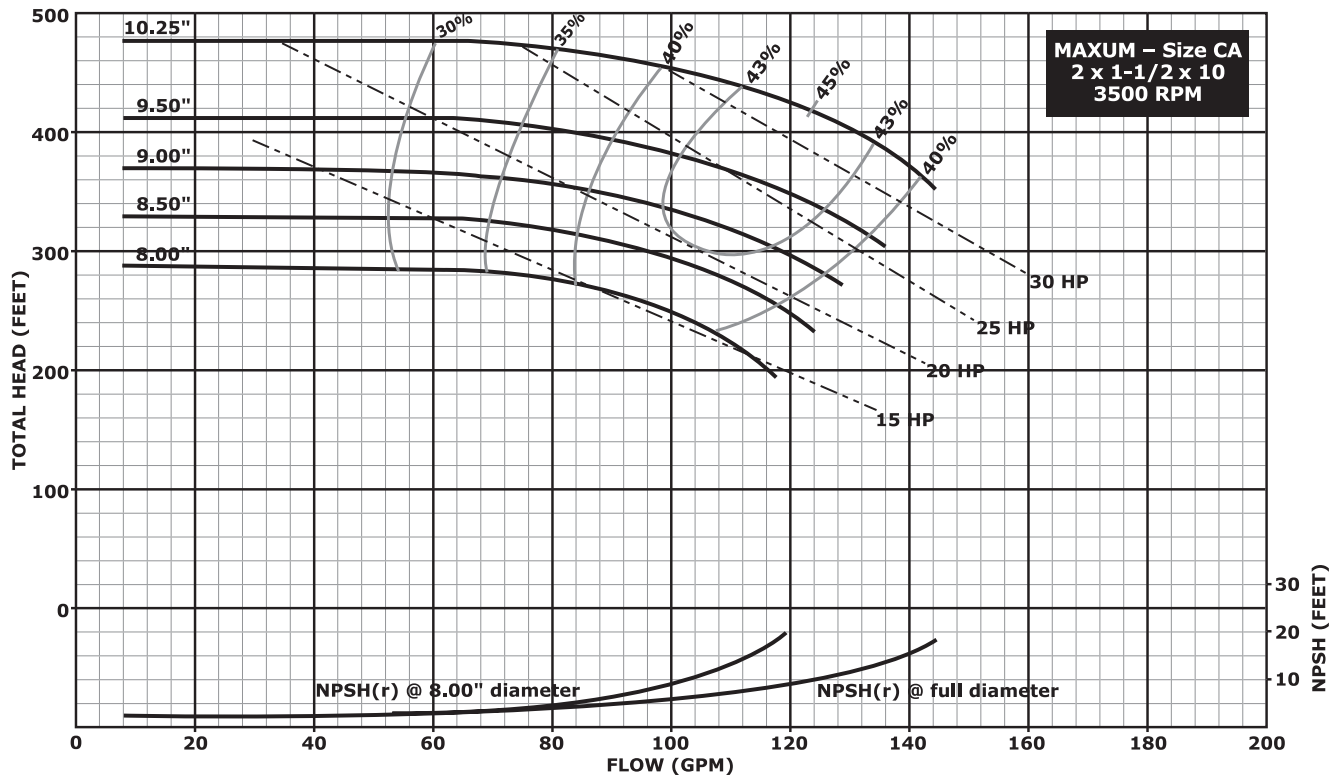

Notes:

1. Above data is based on 1.0 sp. gr. water at ambient temperature and pressure in accordance with Hydraulic Institute guidelines.
2. Impeller diameters between minimum and maximum shown are available in 1/8 inch increment trims.

Hydraulic Performance – 10" Impeller Pumps

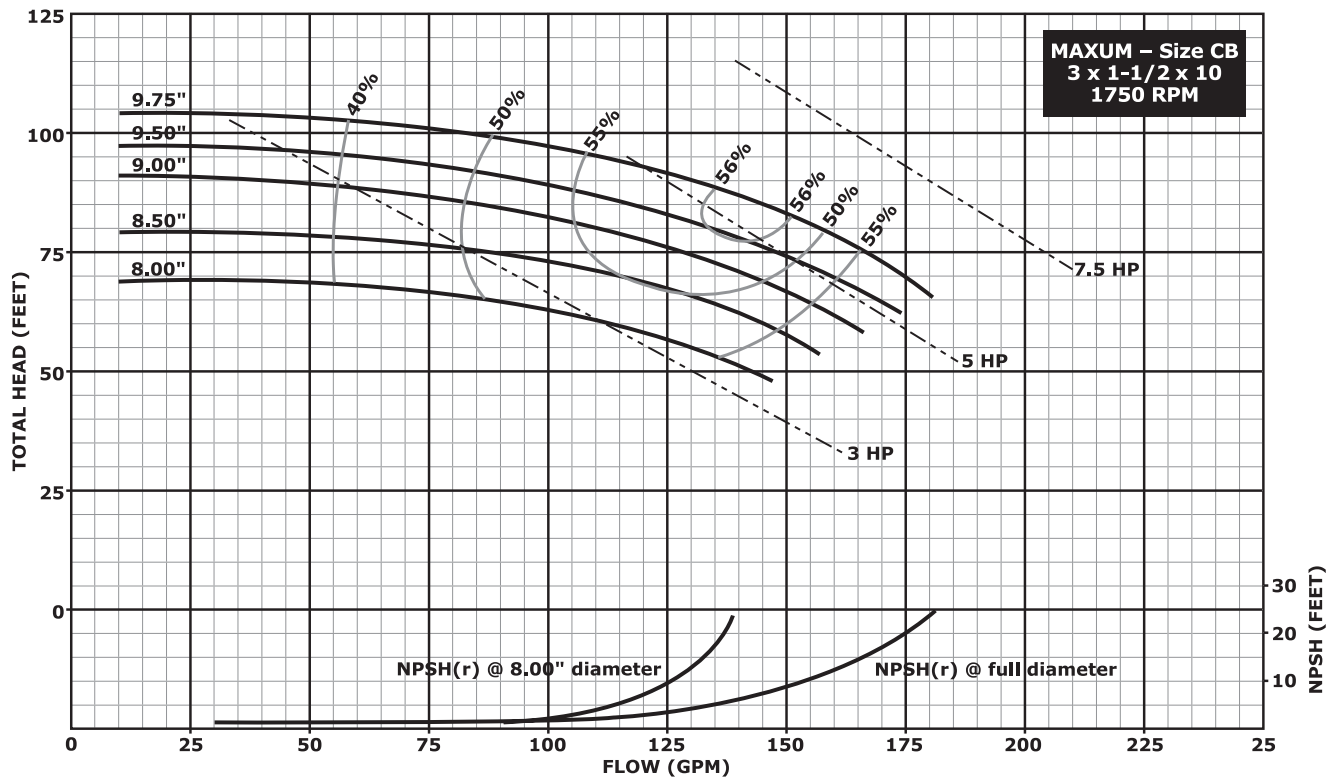
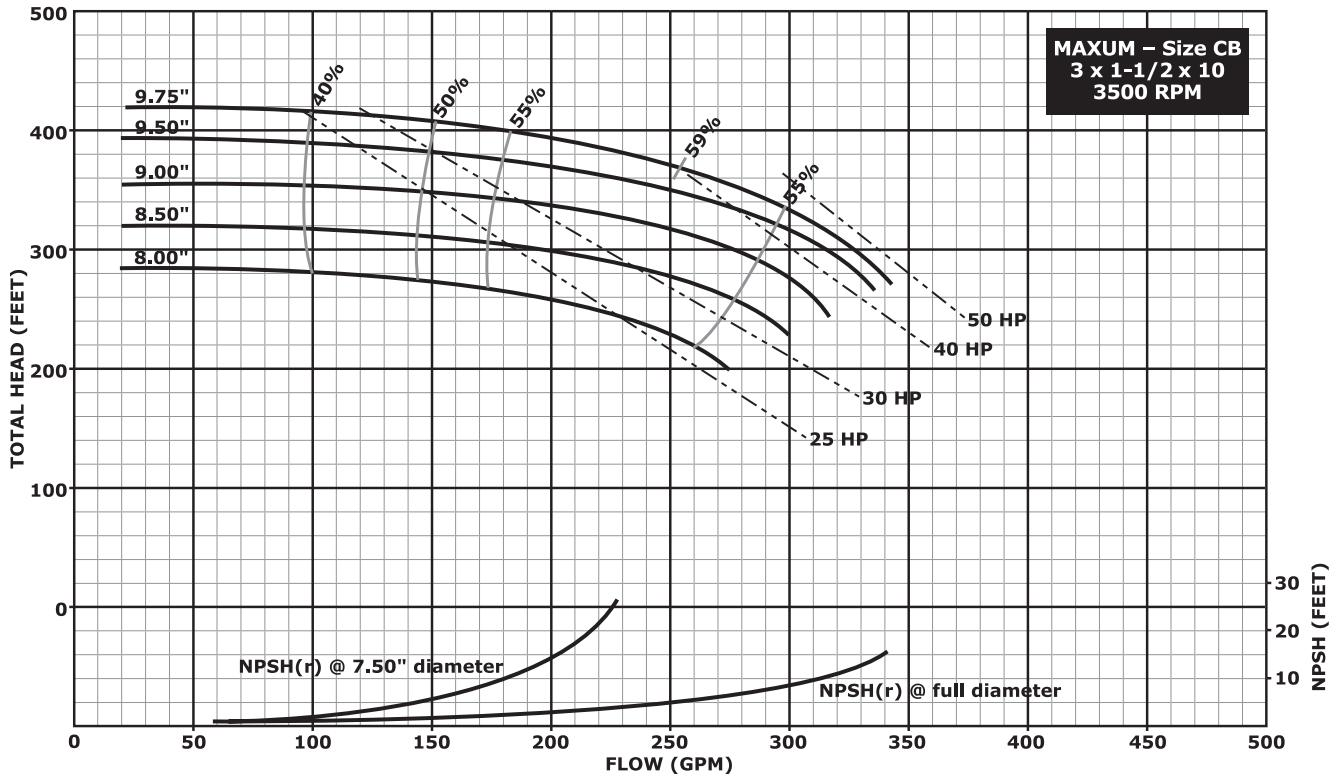

Notes:

1. Above data is based on 1.0 sp. gr. water at ambient temperature and pressure in accordance with Hydraulic Institute guidelines.
2. Impeller diameters between minimum and maximum shown are available in 1/8 inch increment trims.

Hydraulic Performance – 10" Impeller Pumps

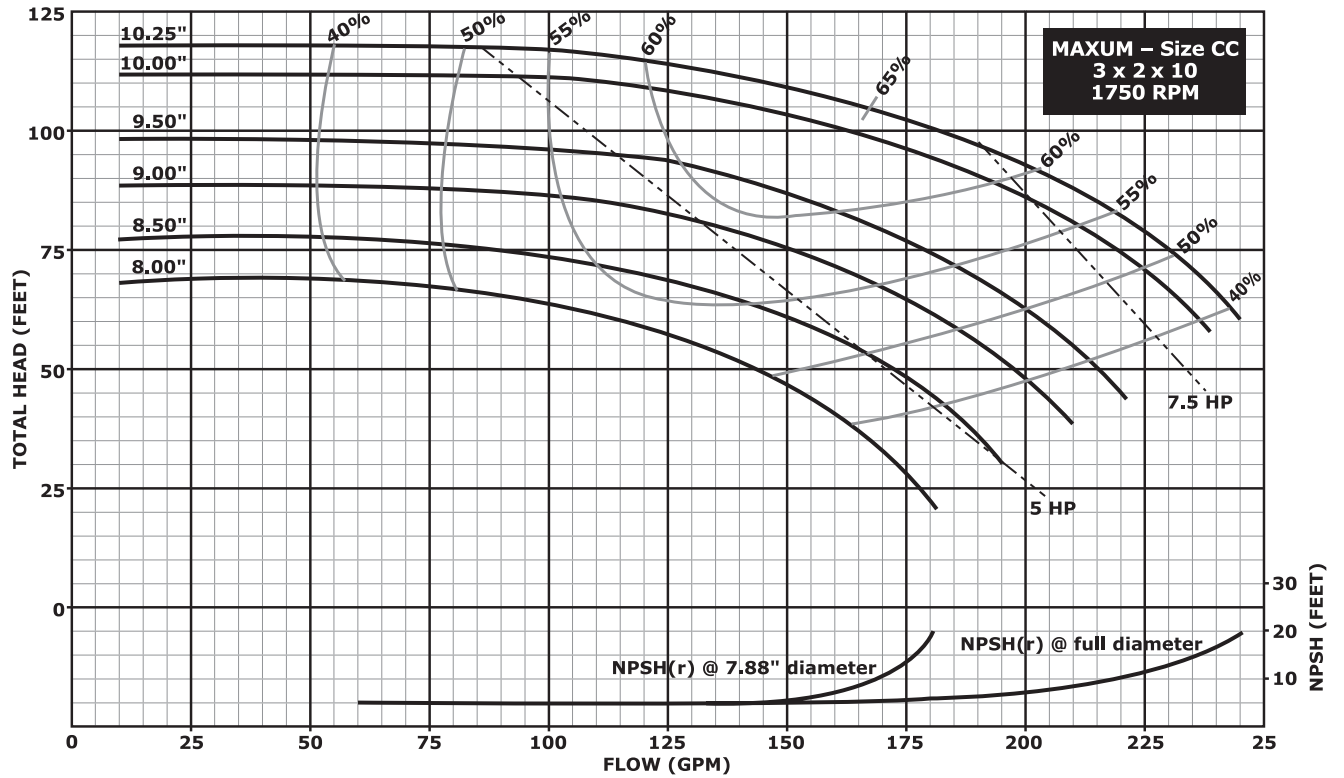
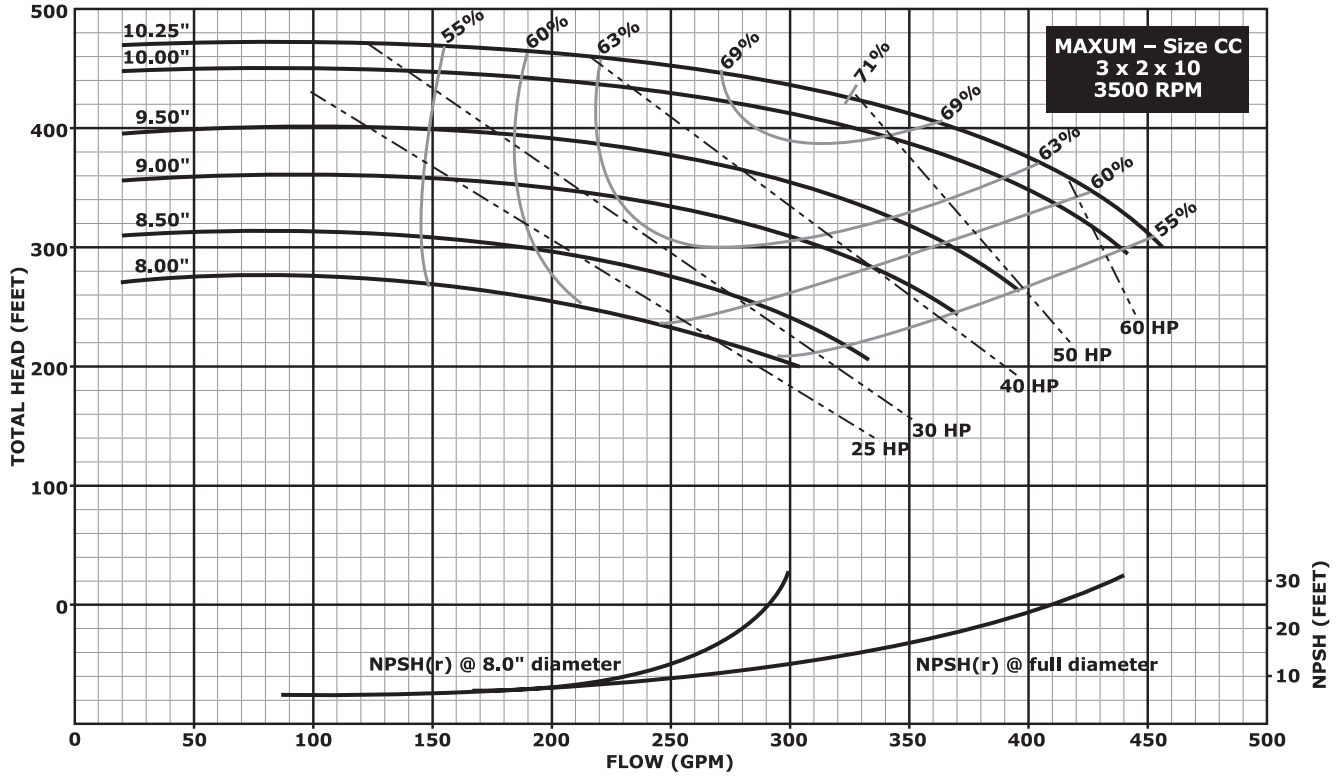

Notes:

1. Above data is based on 1.0 sp. gr. water at ambient temperature and pressure in accordance with Hydraulic Institute guidelines.
2. Impeller diameters between minimum and maximum shown are available in 1/8 inch increment trims.

Hydraulic Performance – 10" Impeller Pumps

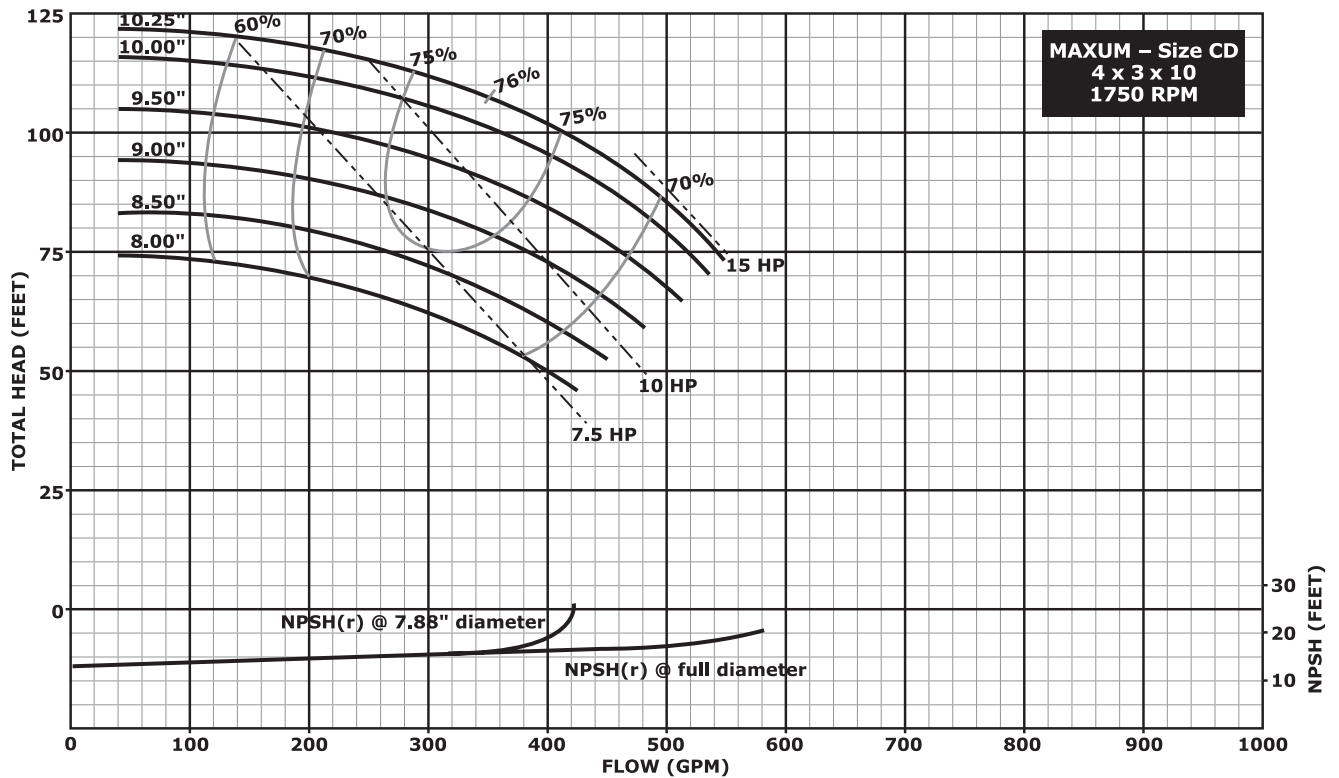
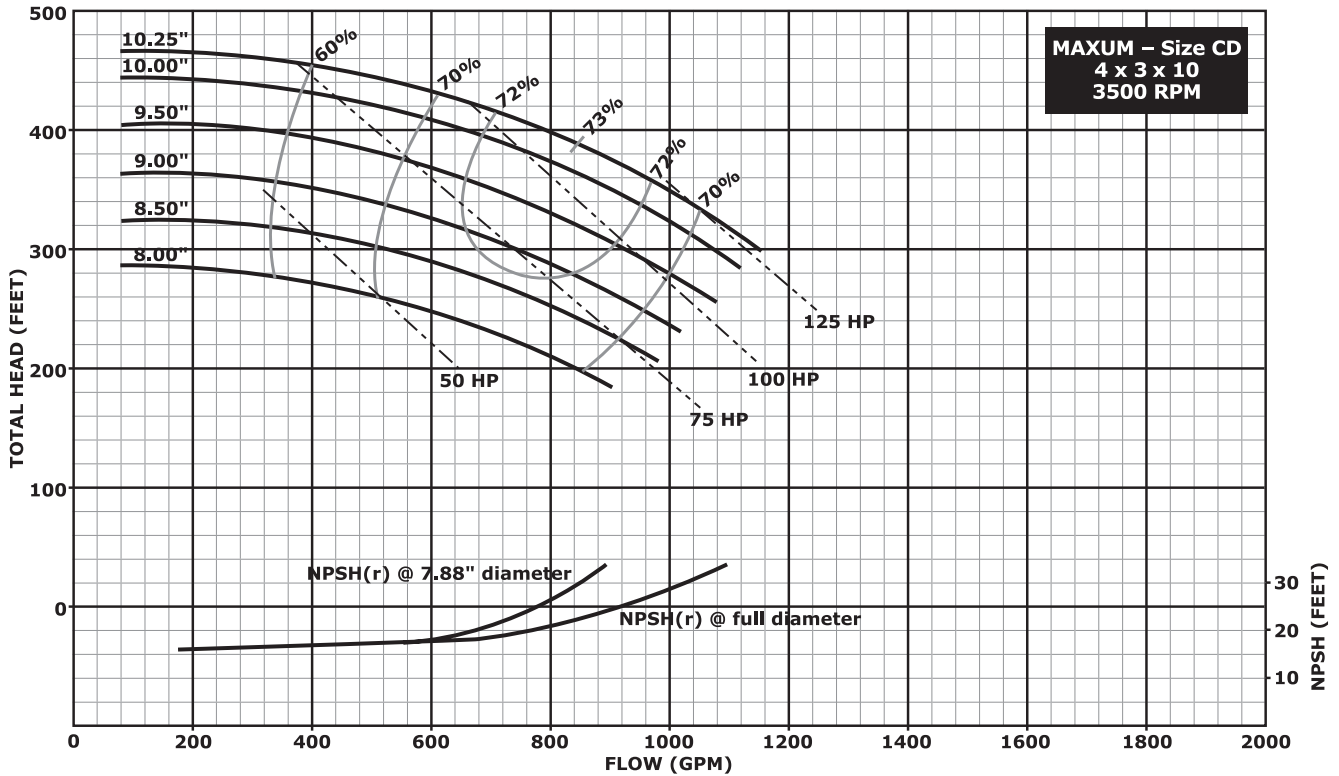

Notes:

1. Above data is based on 1.0 sp. gr. water at ambient temperature and pressure in accordance with Hydraulic Institute guidelines.
2. Impeller diameters between minimum and maximum shown are available in 1/8 inch increment trims.

Hydraulic Performance – 10" Impeller Pumps

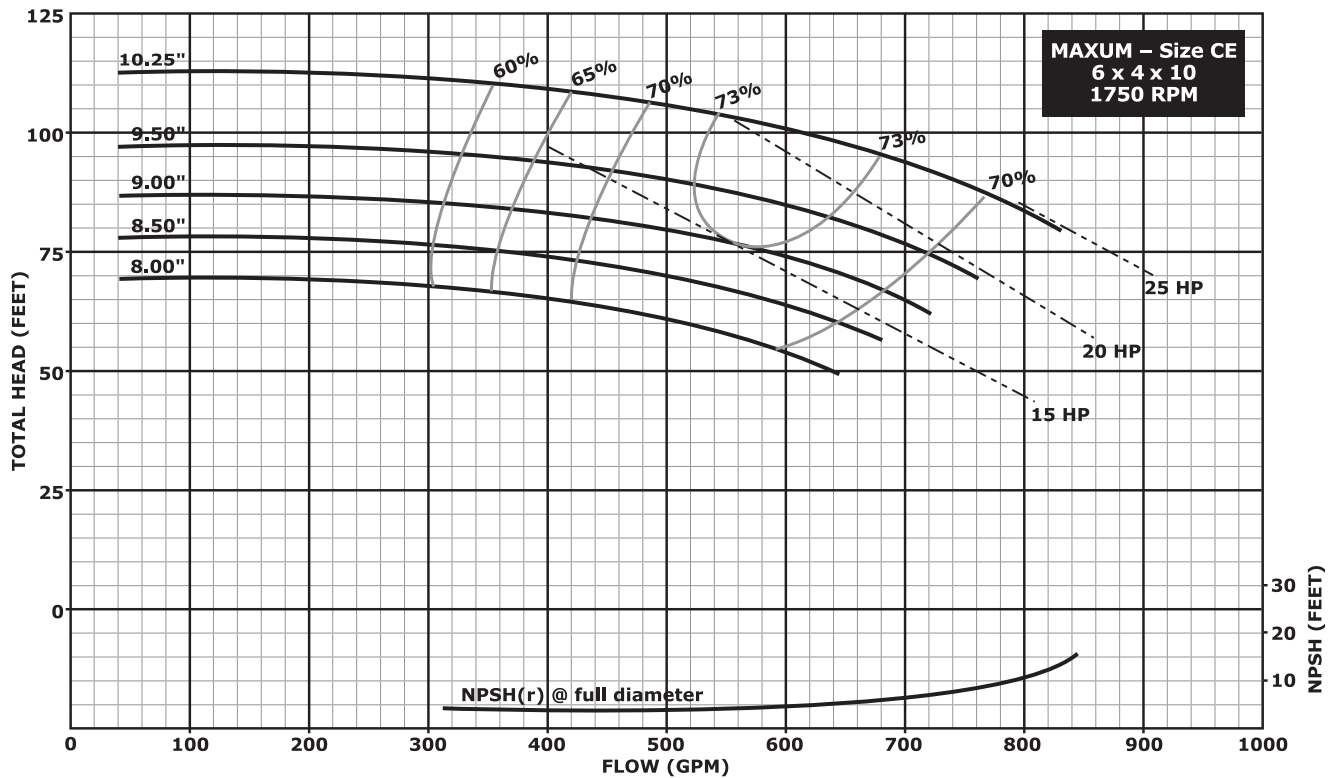
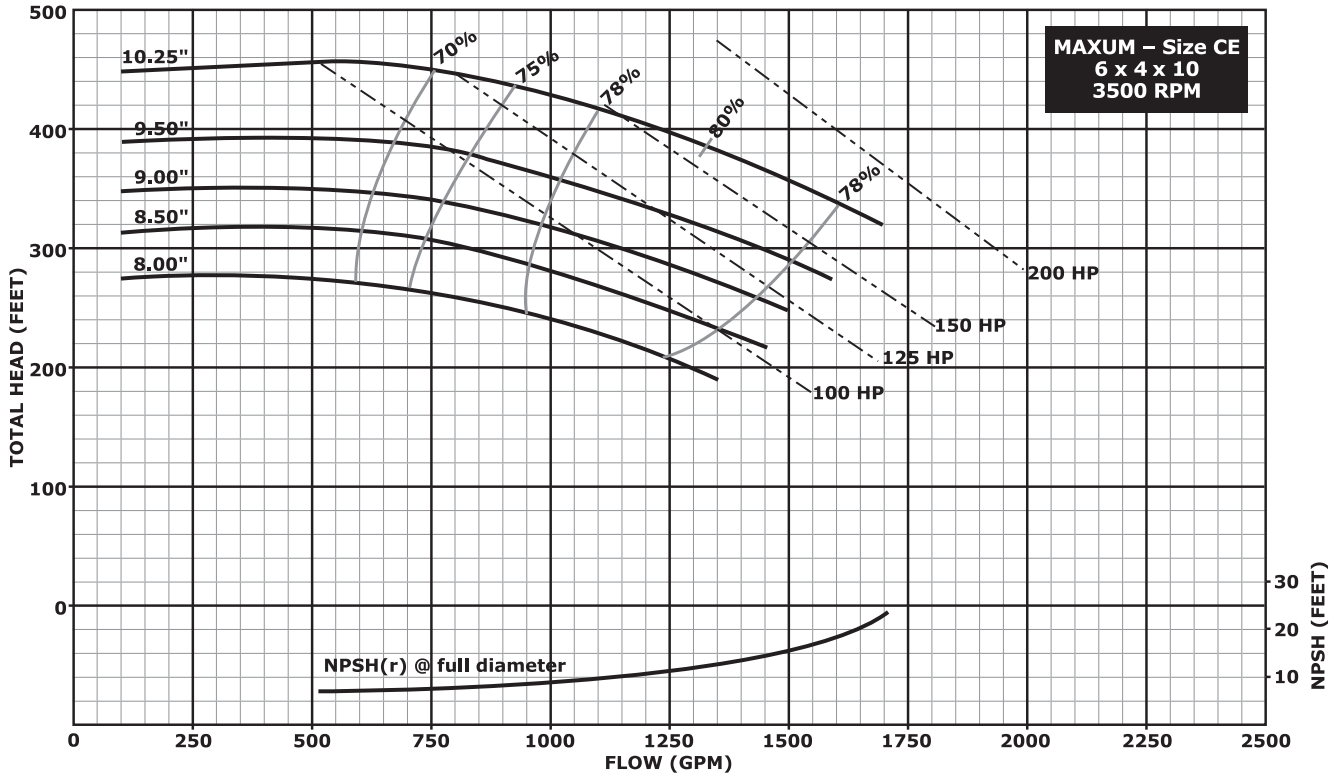

Notes:

1. Above data is based on 1.0 sp. gr. water at ambient temperature and pressure in accordance with Hydraulic Institute guidelines.
2. Impeller diameters between minimum and maximum shown are available in 1/8 inch increment trims.

Hydraulic Performance – 10" Impeller Pumps

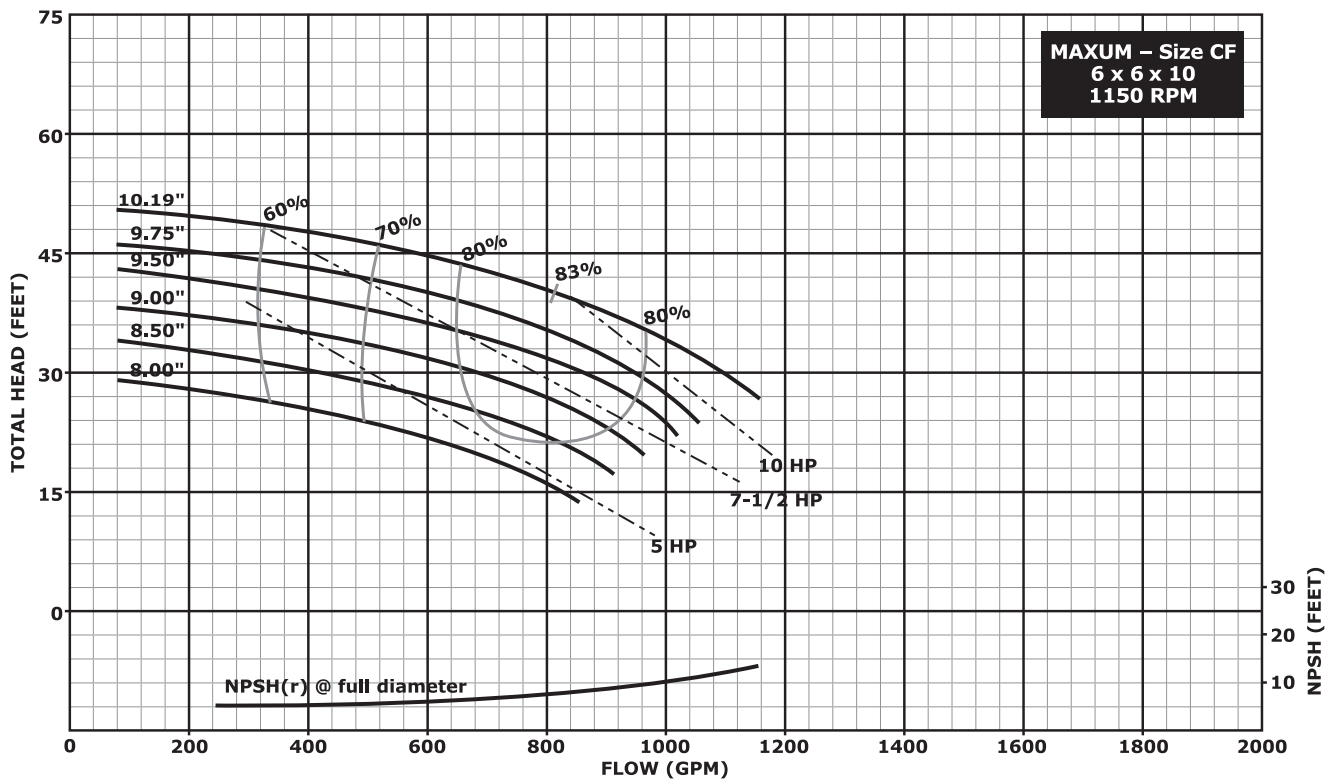
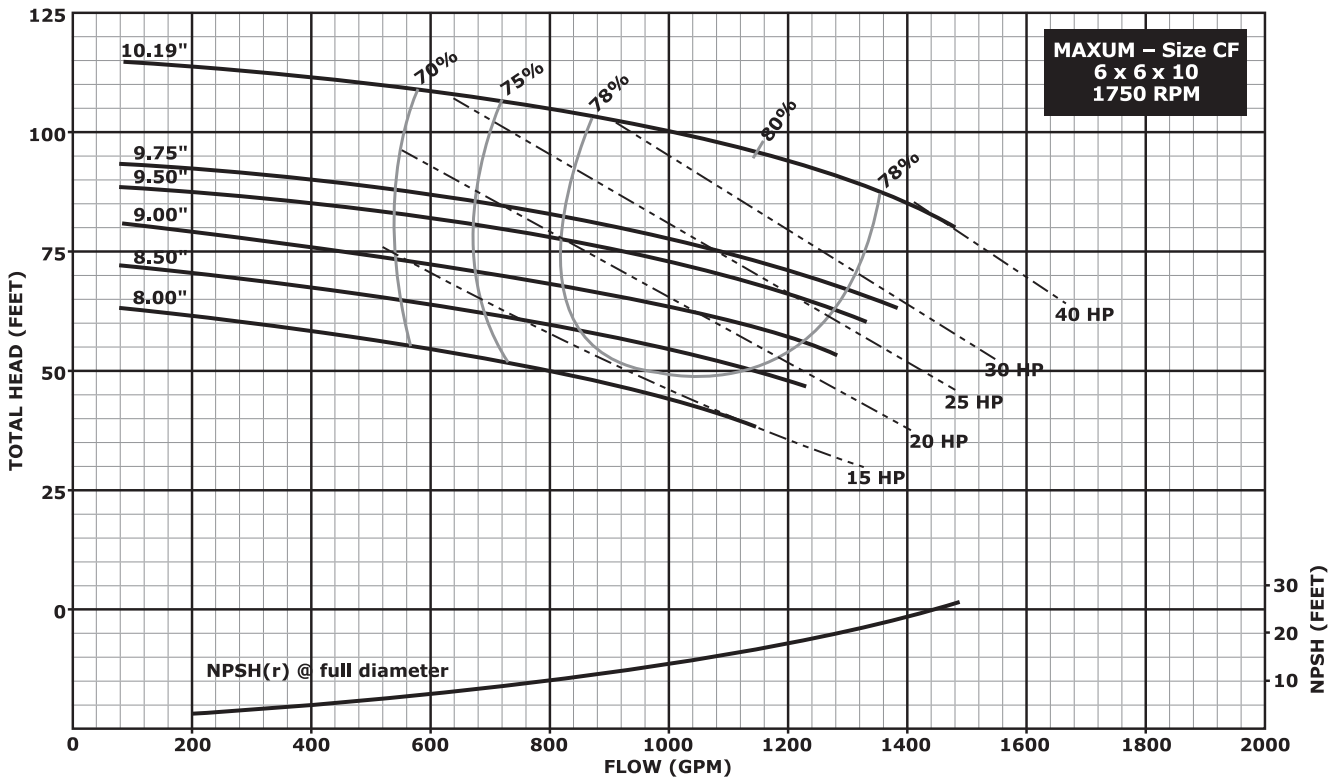

Notes:

1. Above data is based on 1.0 sp. gr. water at ambient temperature and pressure in accordance with Hydraulic Institute guidelines.
2. Impeller diameters between minimum and maximum shown are available in 1/8 inch increment trims.

Hydraulic Performance – 10" Impeller Pumps

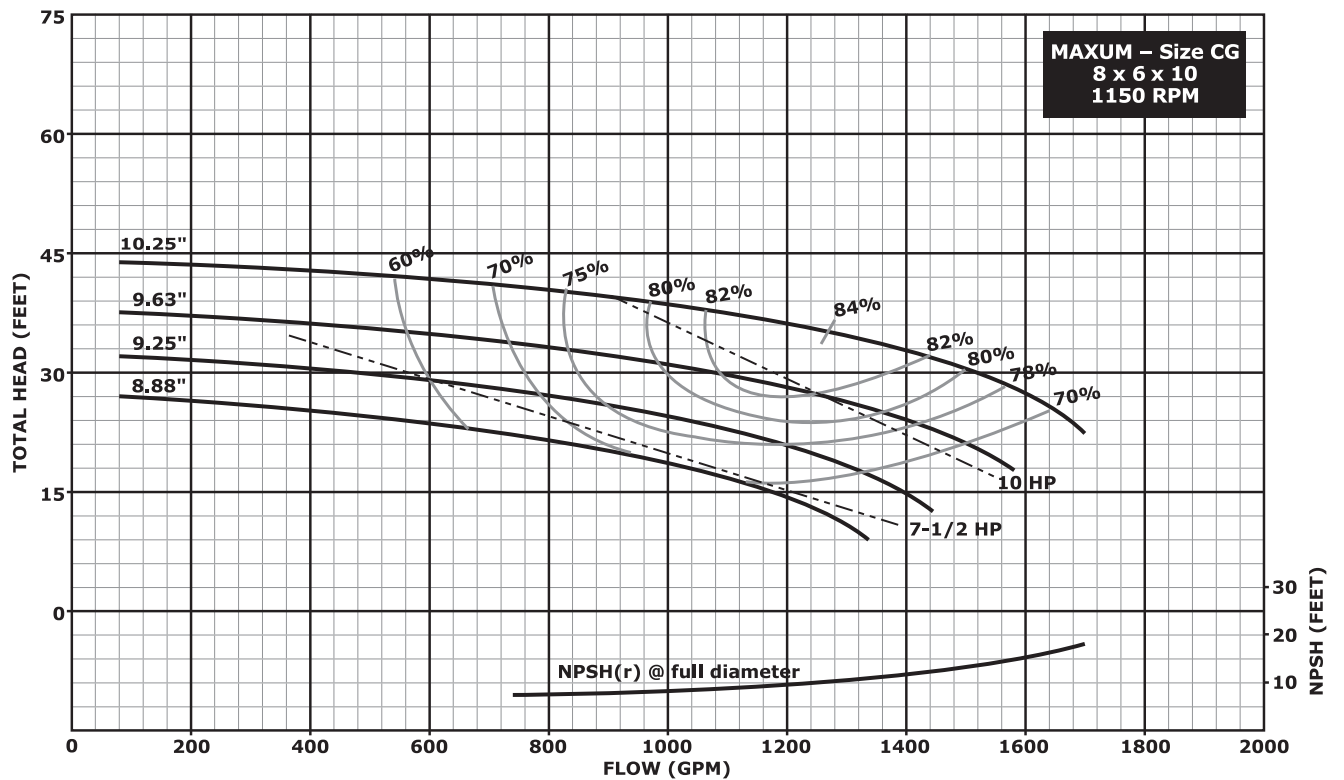
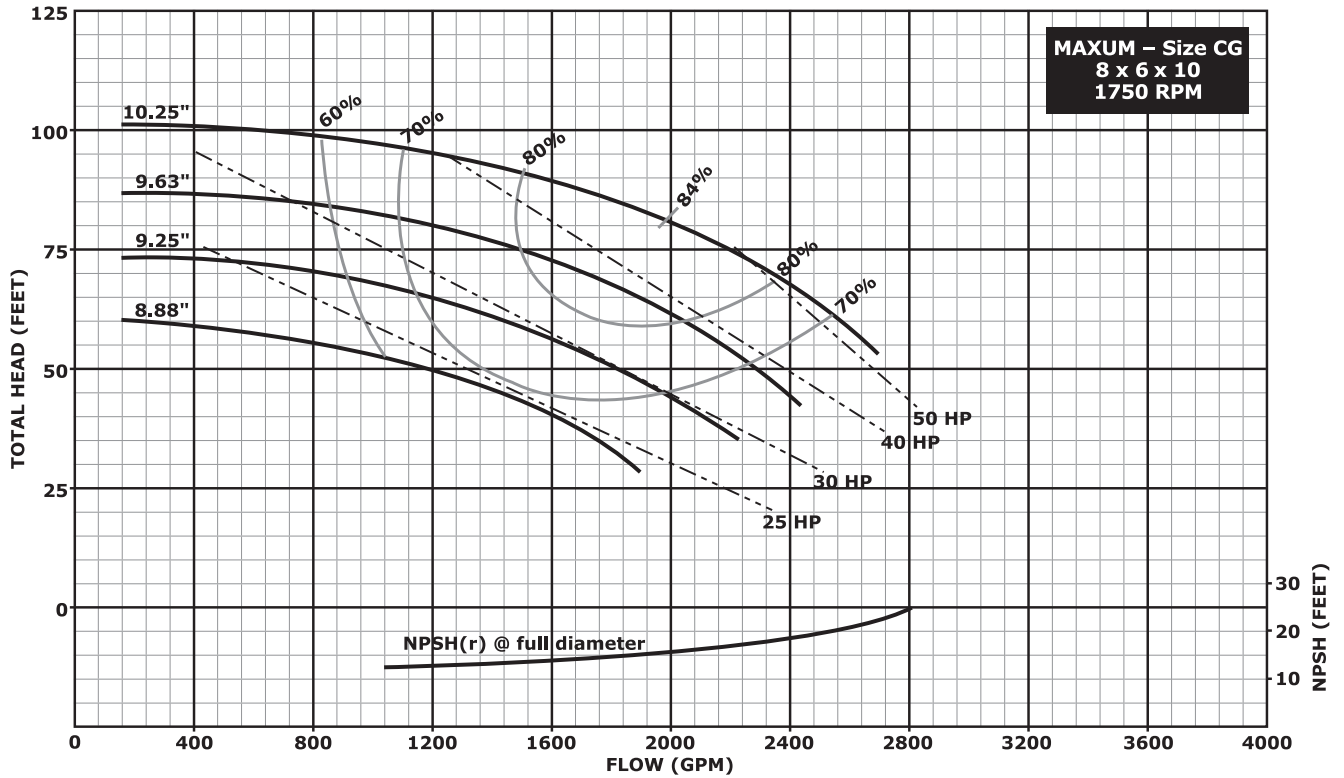

Notes:

1. Above data is based on 1.0 sp. gr. water at ambient temperature and pressure in accordance with Hydraulic Institute guidelines.
2. Impeller diameters between minimum and maximum shown are available in 1/8 inch increment trims.

Hydraulic Performance – 13" Impeller Pumps

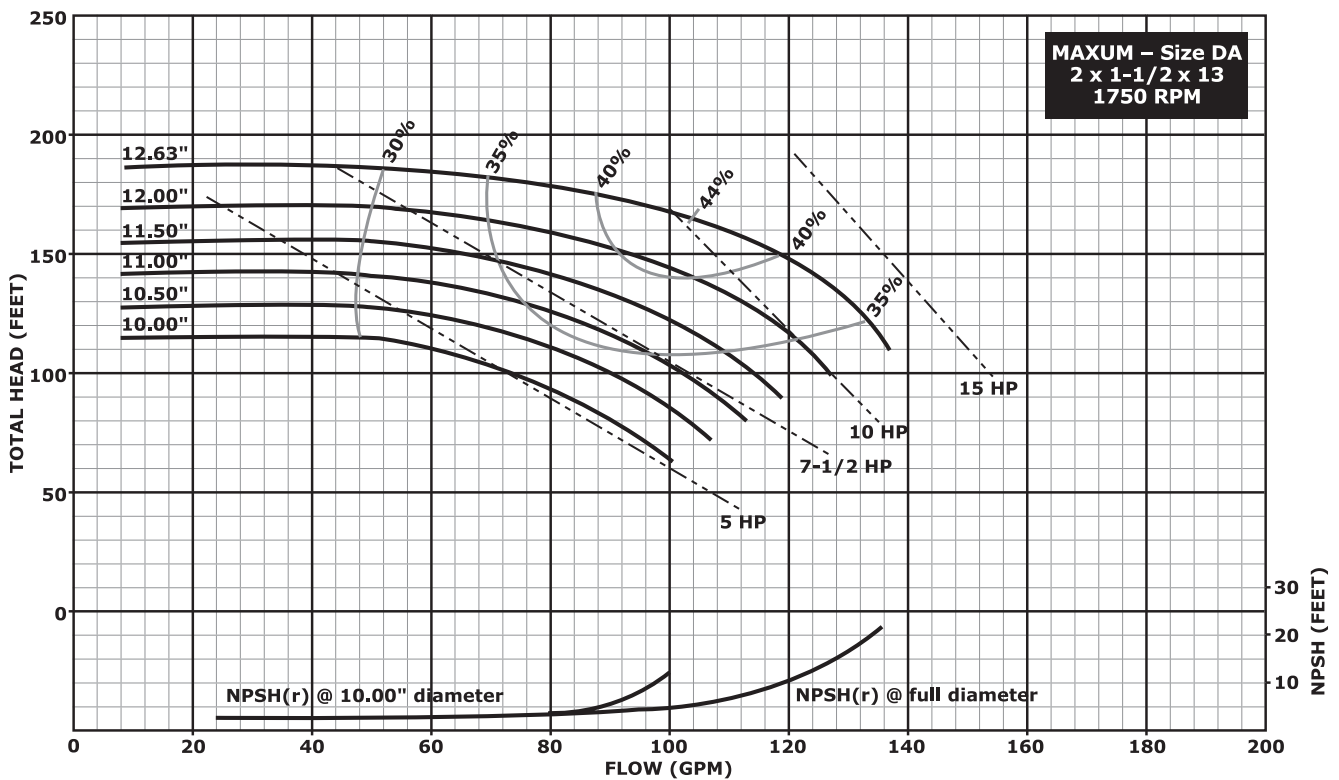
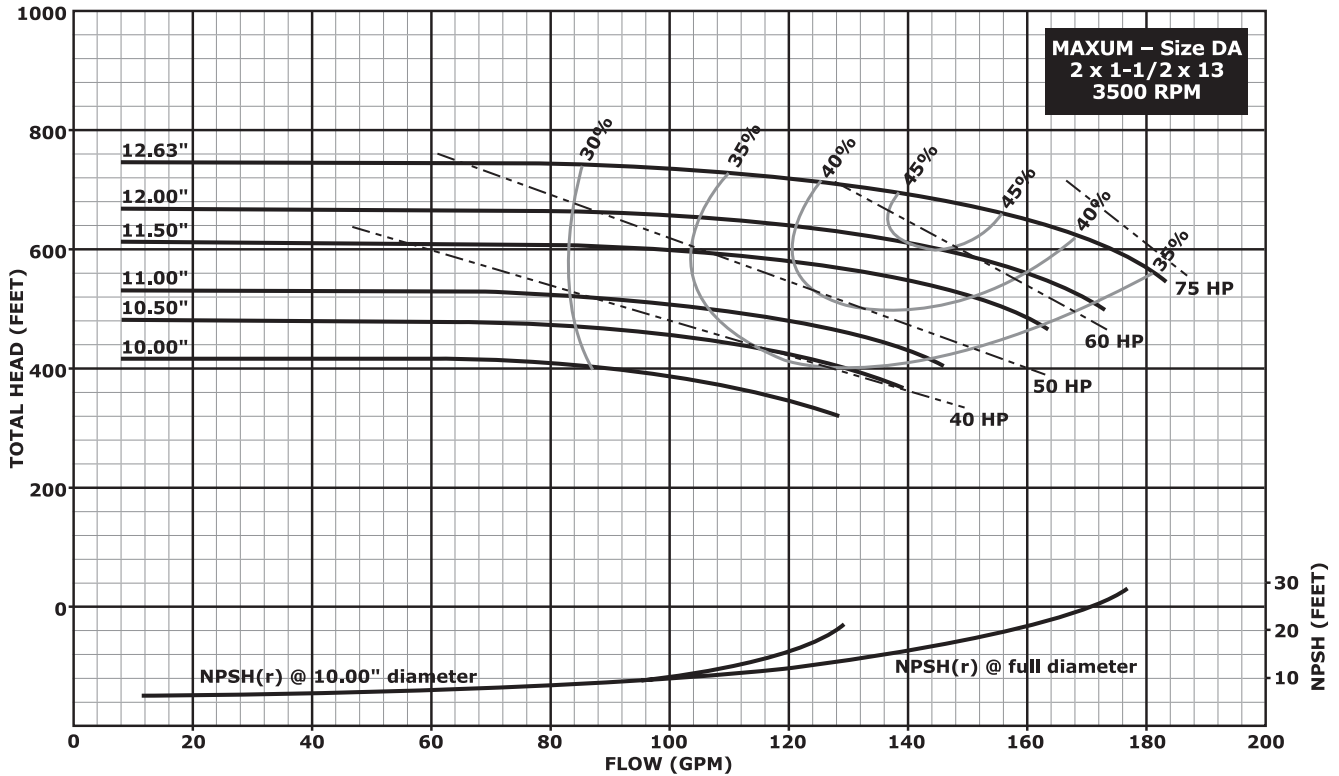

Notes:

1. Above data is based on 1.0 sp. gr. water at ambient temperature and pressure in accordance with Hydraulic Institute guidelines.
2. Impeller diameters between minimum and maximum shown are available in 1/8 inch increment trims.

Hydraulic Performance – 13" Impeller Pumps

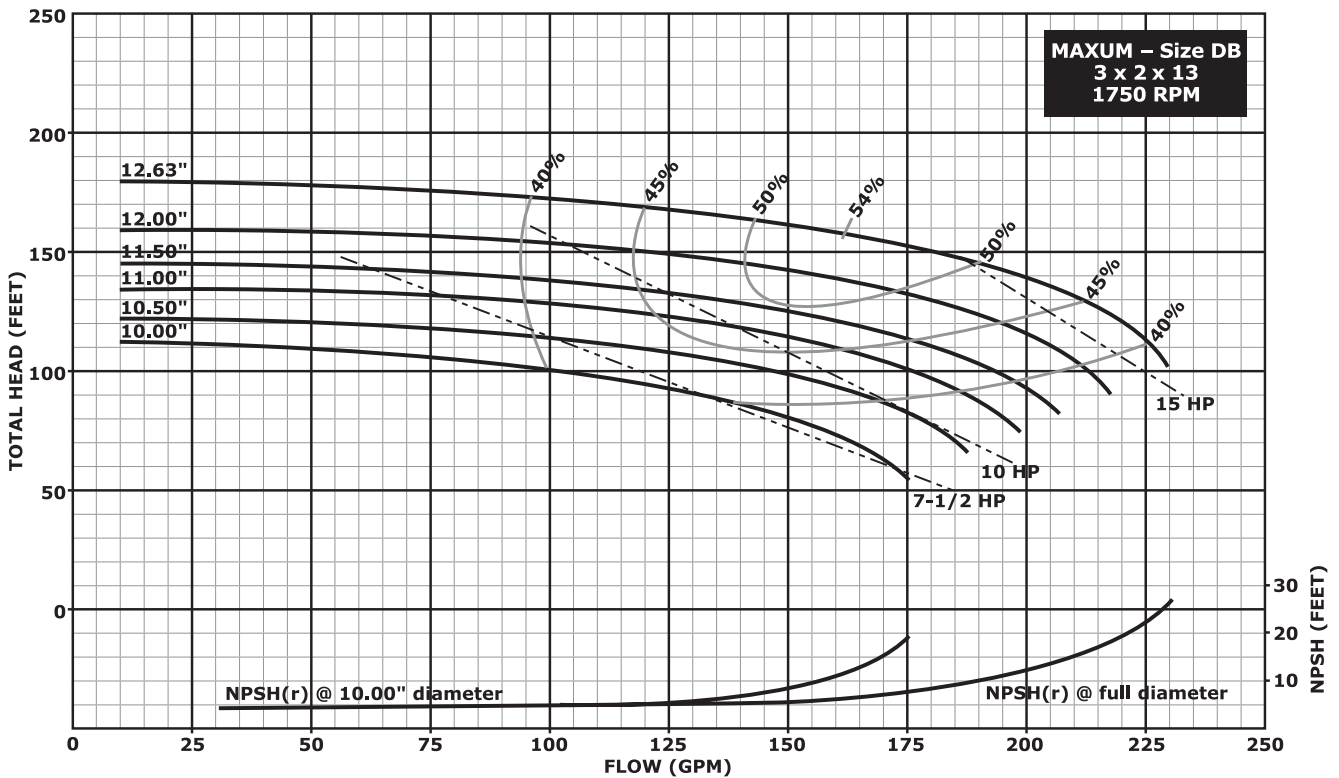
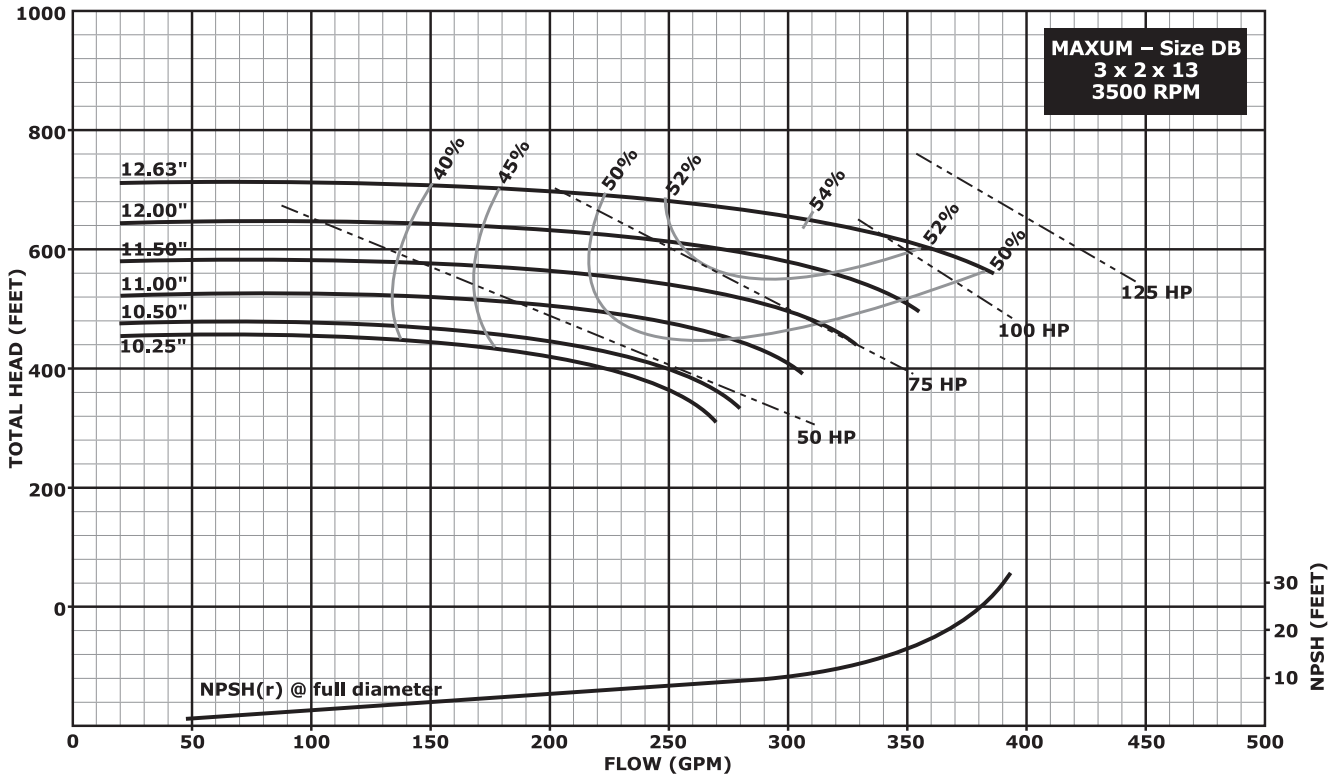

Notes:

1. Above data is based on 1.0 sp. gr. water at ambient temperature and pressure in accordance with Hydraulic Institute guidelines.
2. Impeller diameters between minimum and maximum shown are available in 1/8 inch increment trims.

Hydraulic Performance – 13" Impeller Pumps

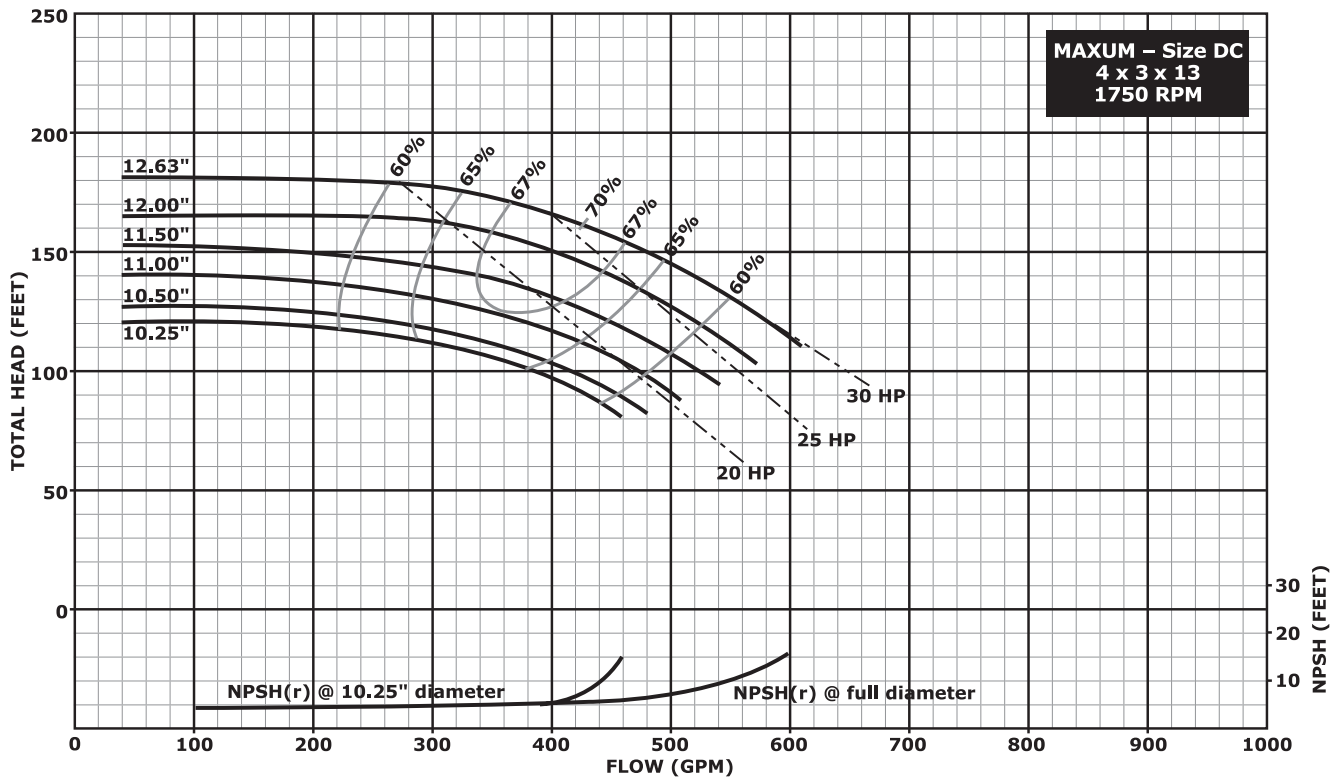
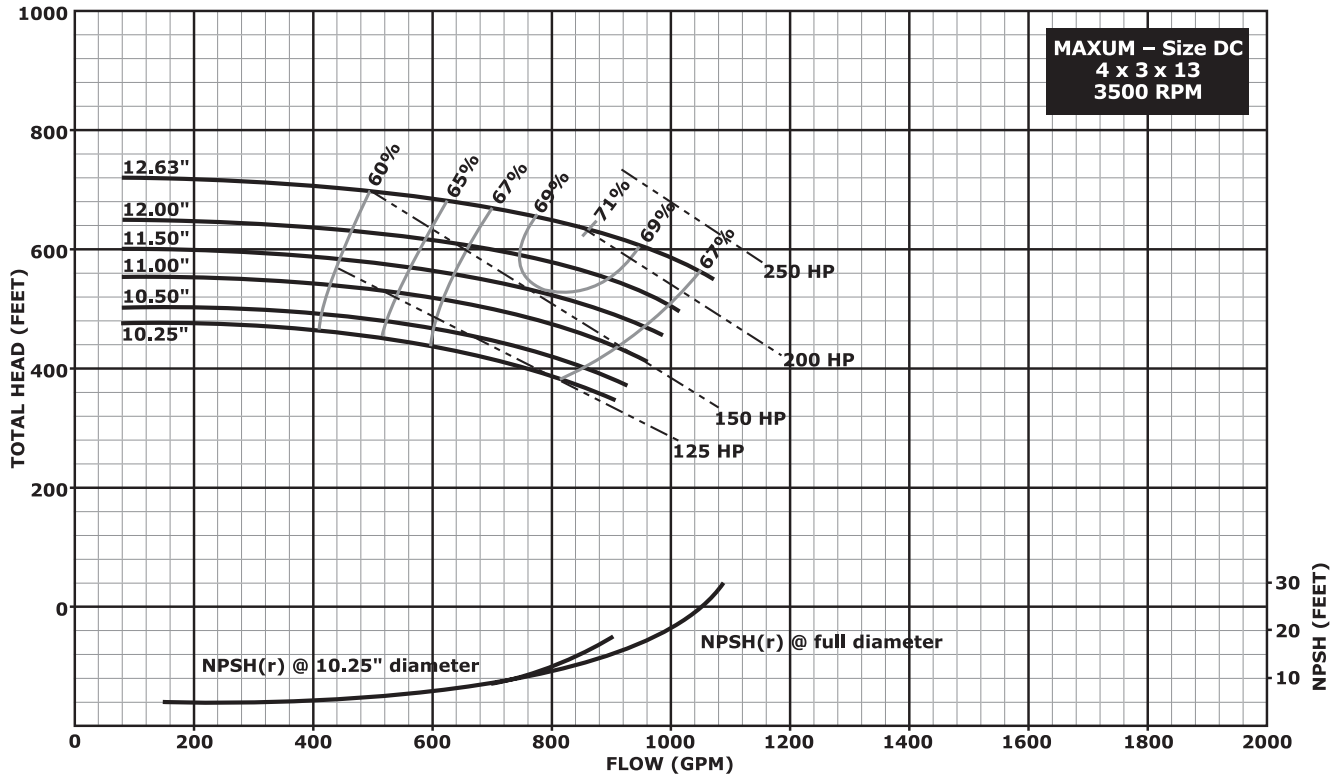

Notes:

1. Above data is based on 1.0 sp. gr. water at ambient temperature and pressure in accordance with Hydraulic Institute guidelines.
2. Impeller diameters between minimum and maximum shown are available in 1/8 inch increment trims.

Hydraulic Performance – 13" Impeller Pumps

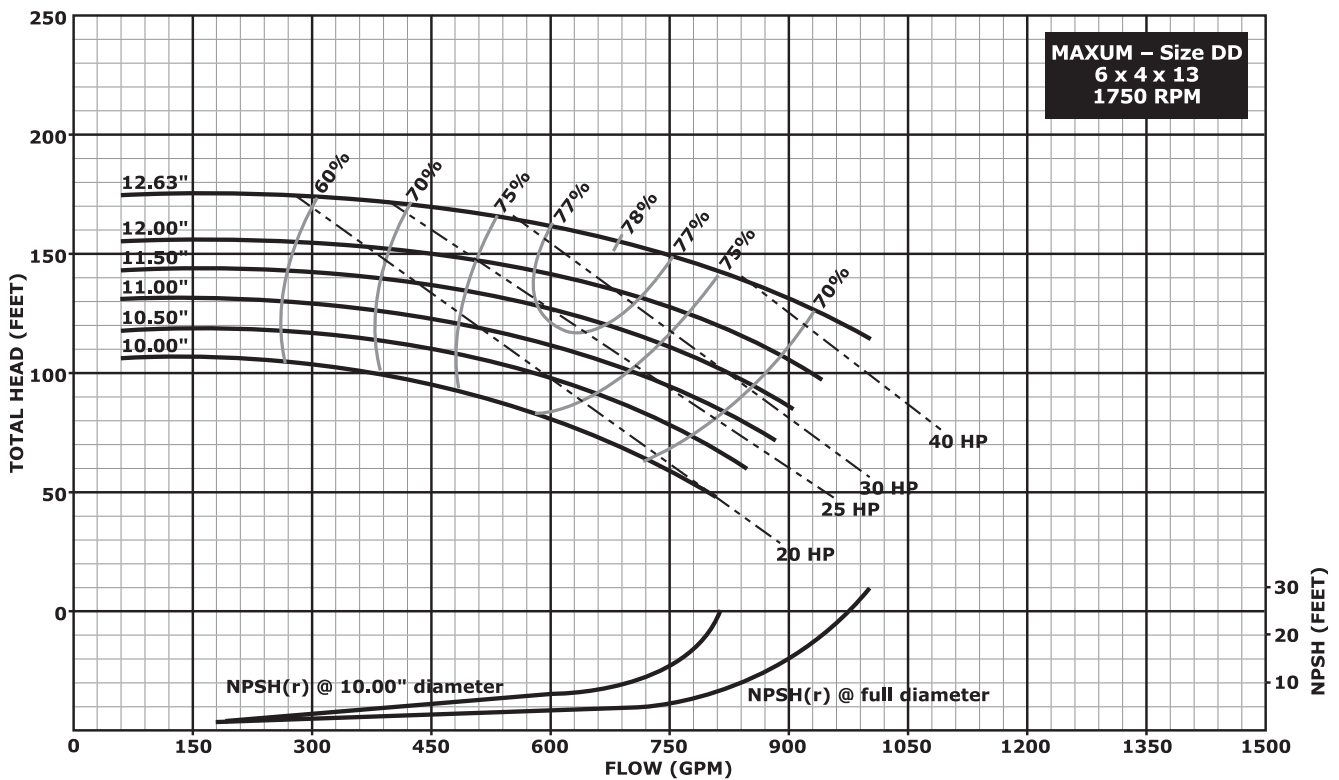
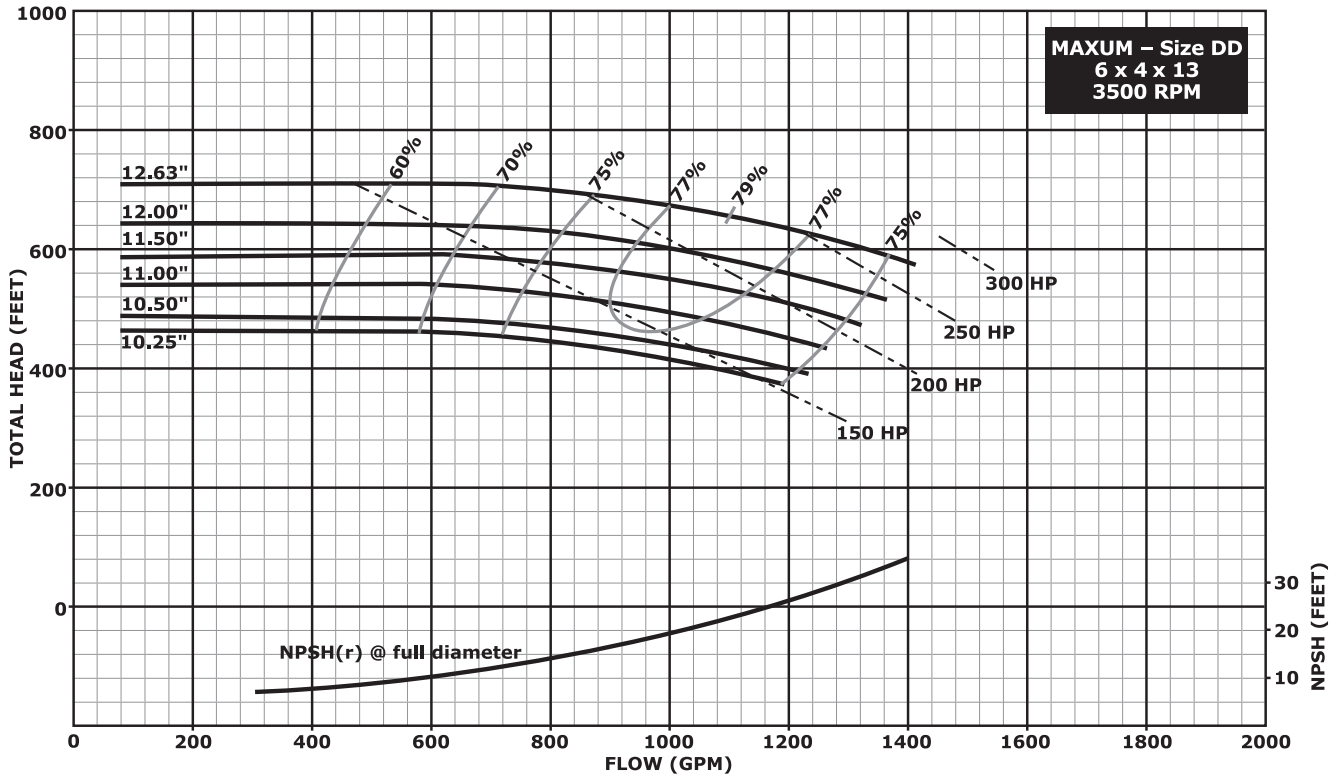

Notes:

1. Above data is based on 1.0 sp. gr. water at ambient temperature and pressure in accordance with Hydraulic Institute guidelines.
2. Impeller diameters between minimum and maximum shown are available in 1/8 inch increment trims.

Hydraulic Performance – 13" Impeller Pumps

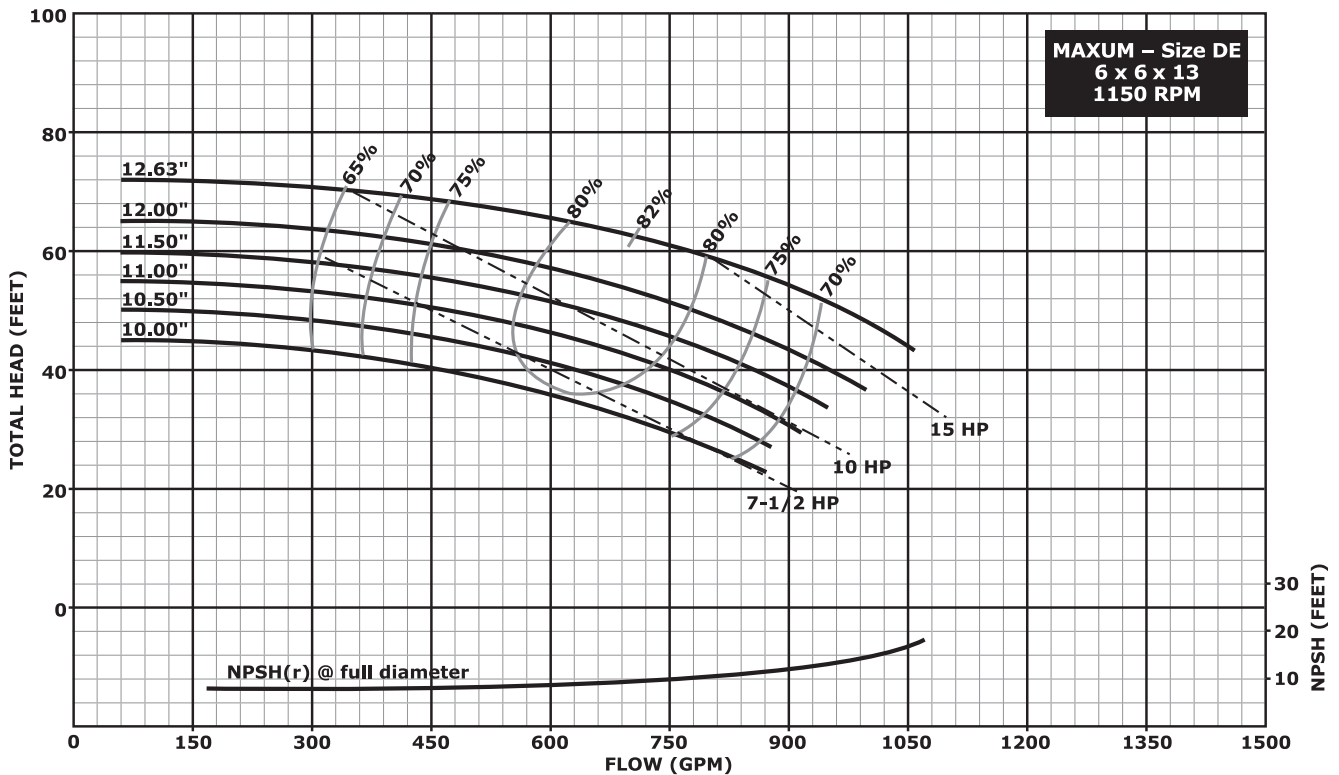
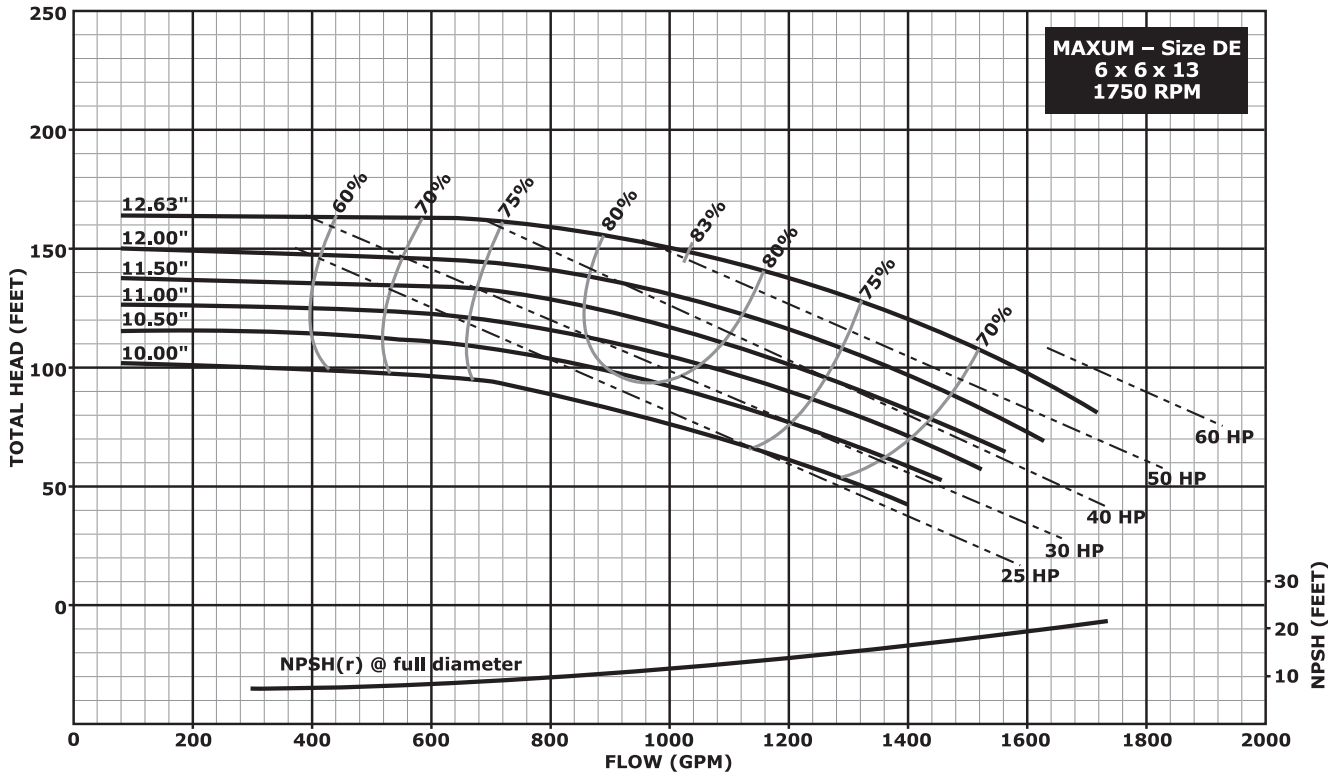

Notes:

1. Above data is based on 1.0 sp. gr. water at ambient temperature and pressure in accordance with Hydraulic Institute guidelines.
2. Impeller diameters between minimum and maximum shown are available in 1/8 inch increment trims.

Hydraulic Performance – 13" Impeller Pumps

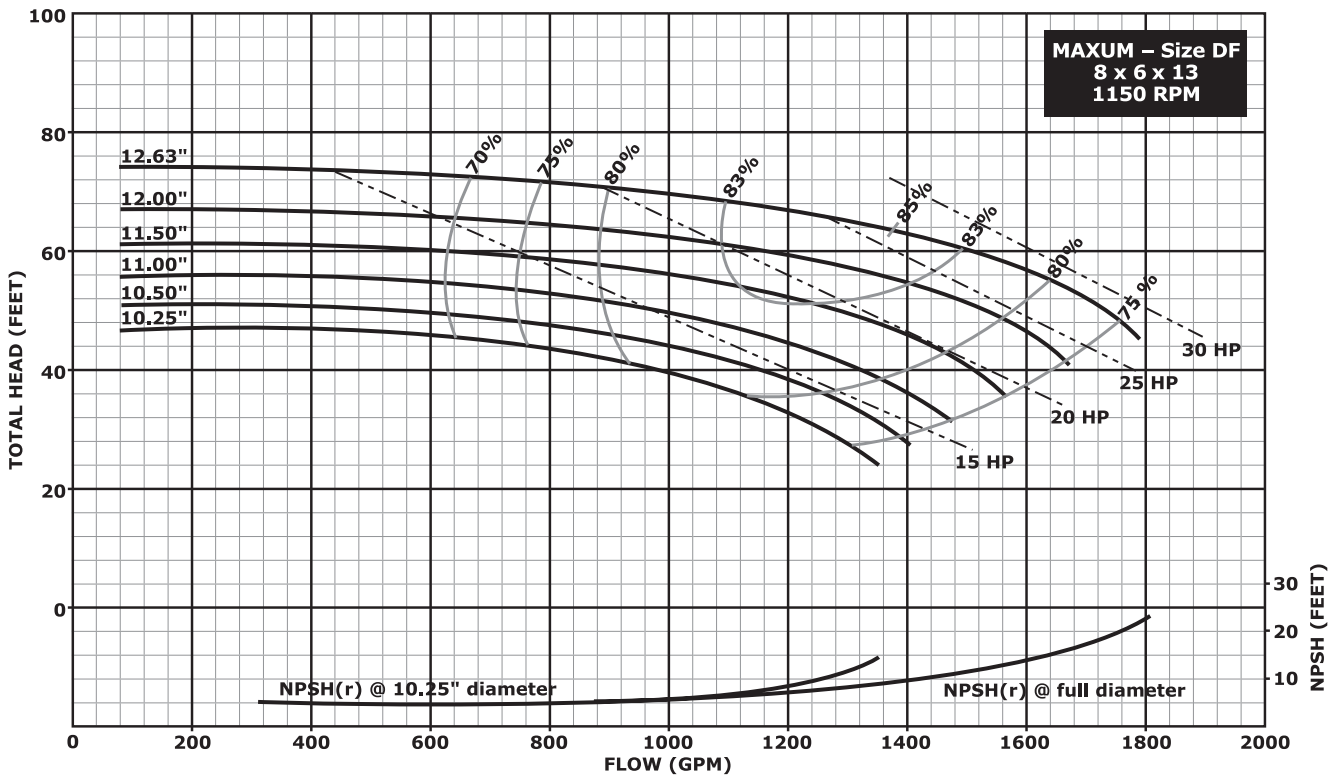
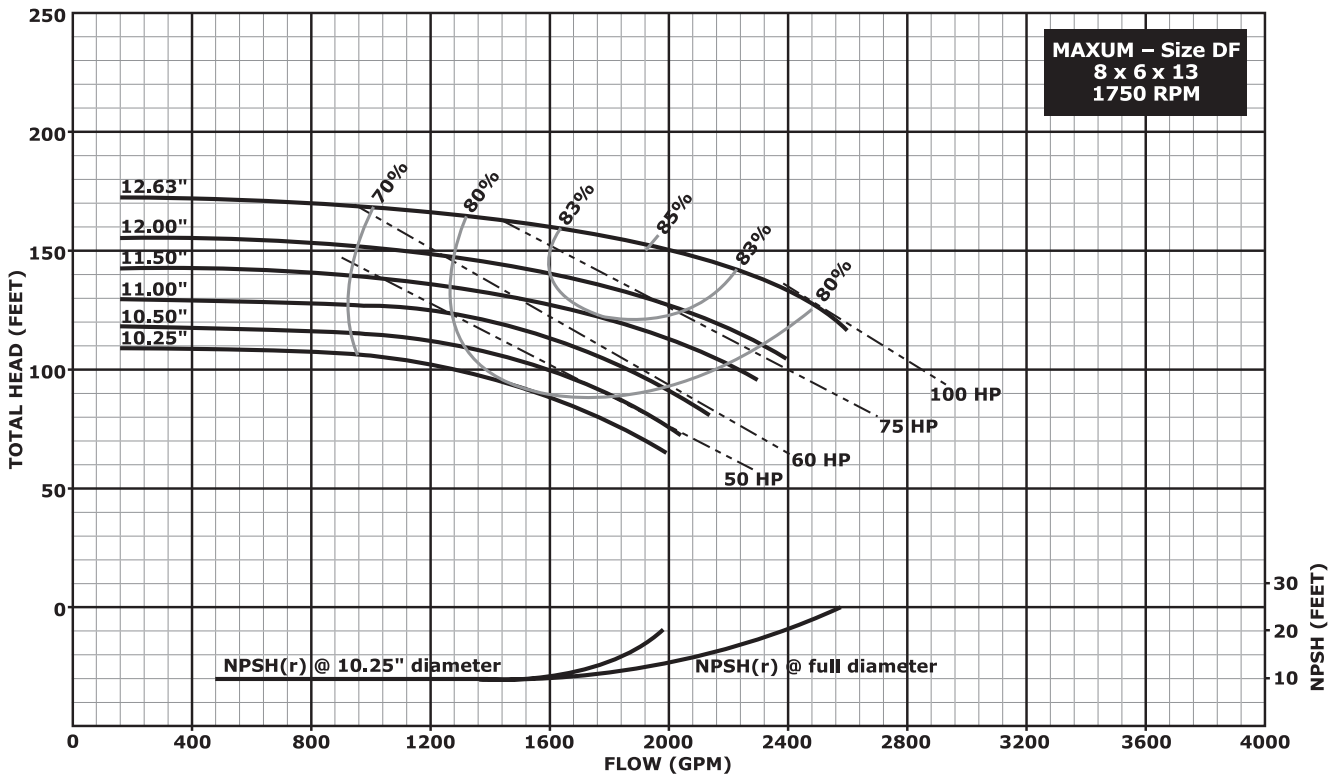

Notes:

1. Above data is based on 1.0 sp. gr. water at ambient temperature and pressure in accordance with Hydraulic Institute guidelines.
2. Impeller diameters between minimum and maximum shown are available in 1/8 inch increment trims.

Hydraulic Performance – 13" Impeller Pumps

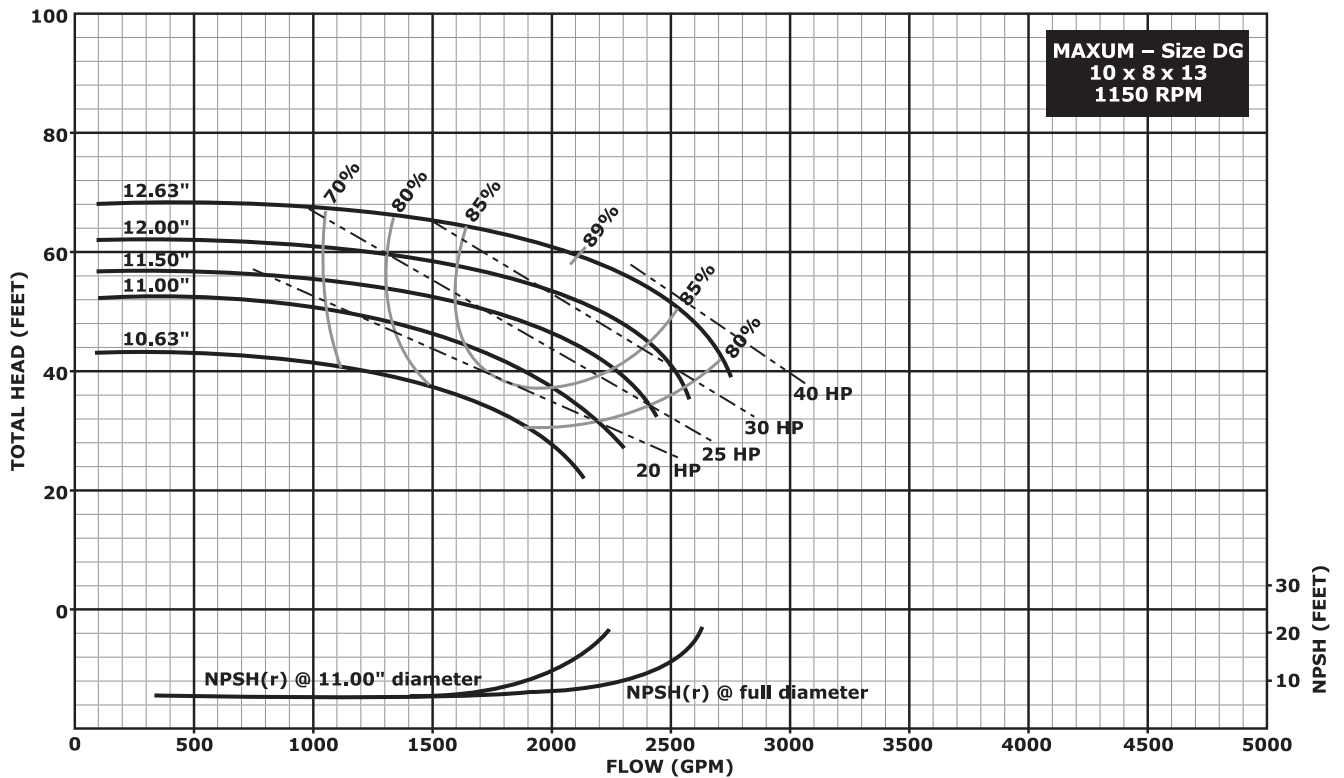
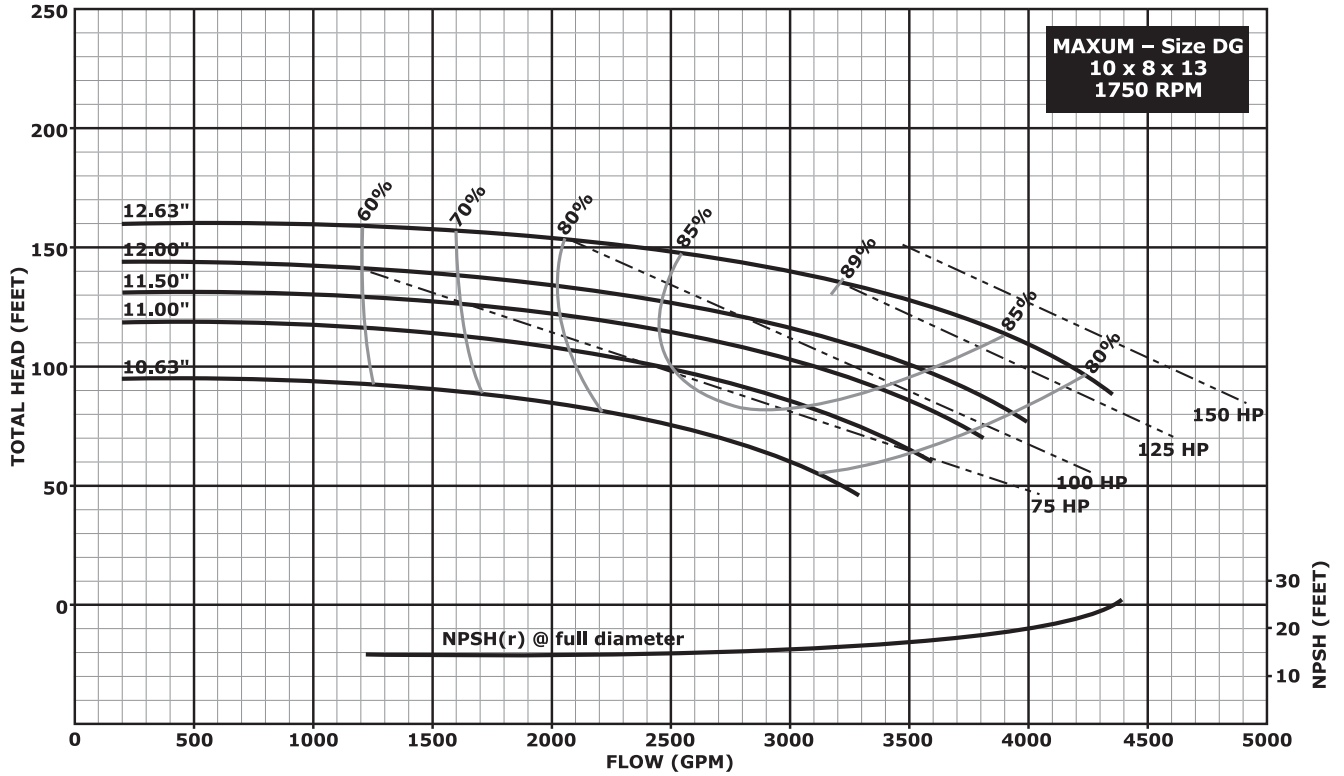

Notes:

1. Above data is based on 1.0 sp. gr. water at ambient temperature and pressure in accordance with Hydraulic Institute guidelines.
2. This is a mixed flow impeller pump, and trimming is accomplished by angular vane cuts. Impeller diameter trims shown are approximations only.

Hydraulic Performance – 13" Impeller Pumps

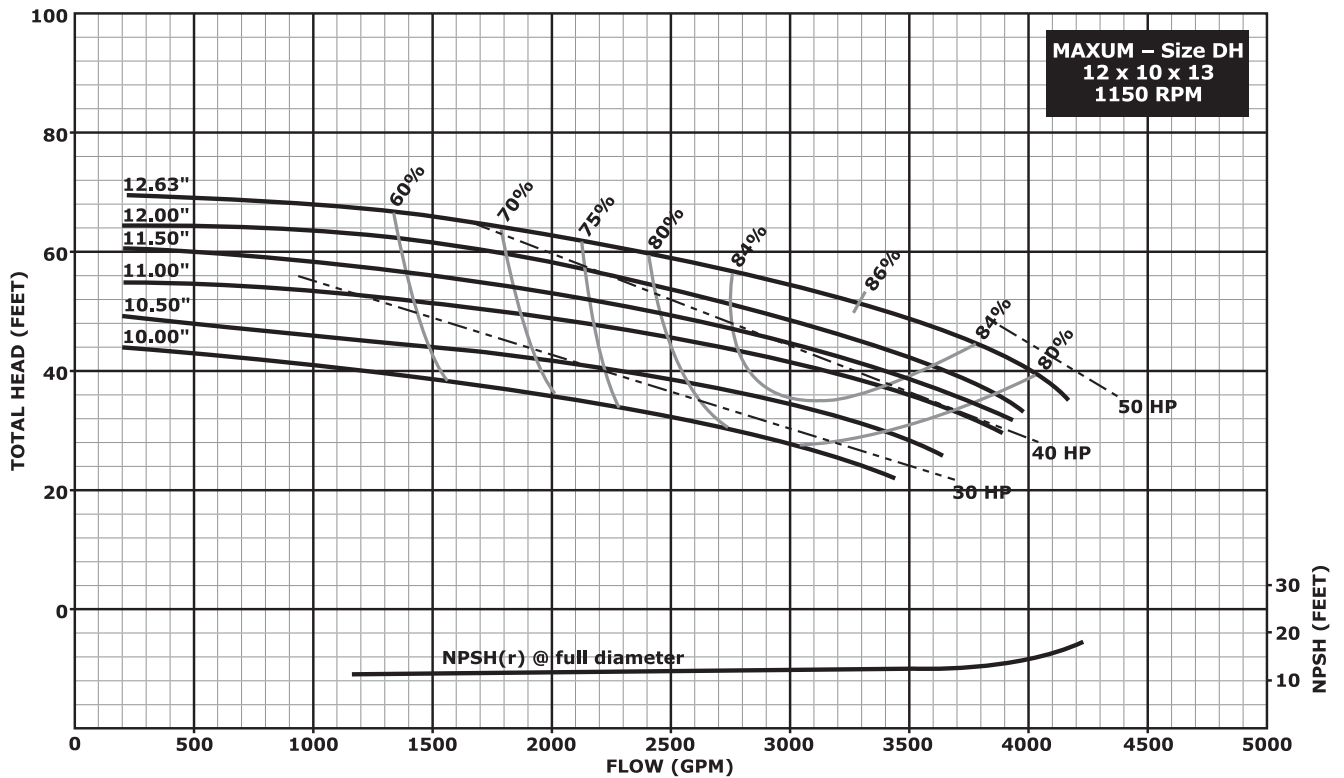
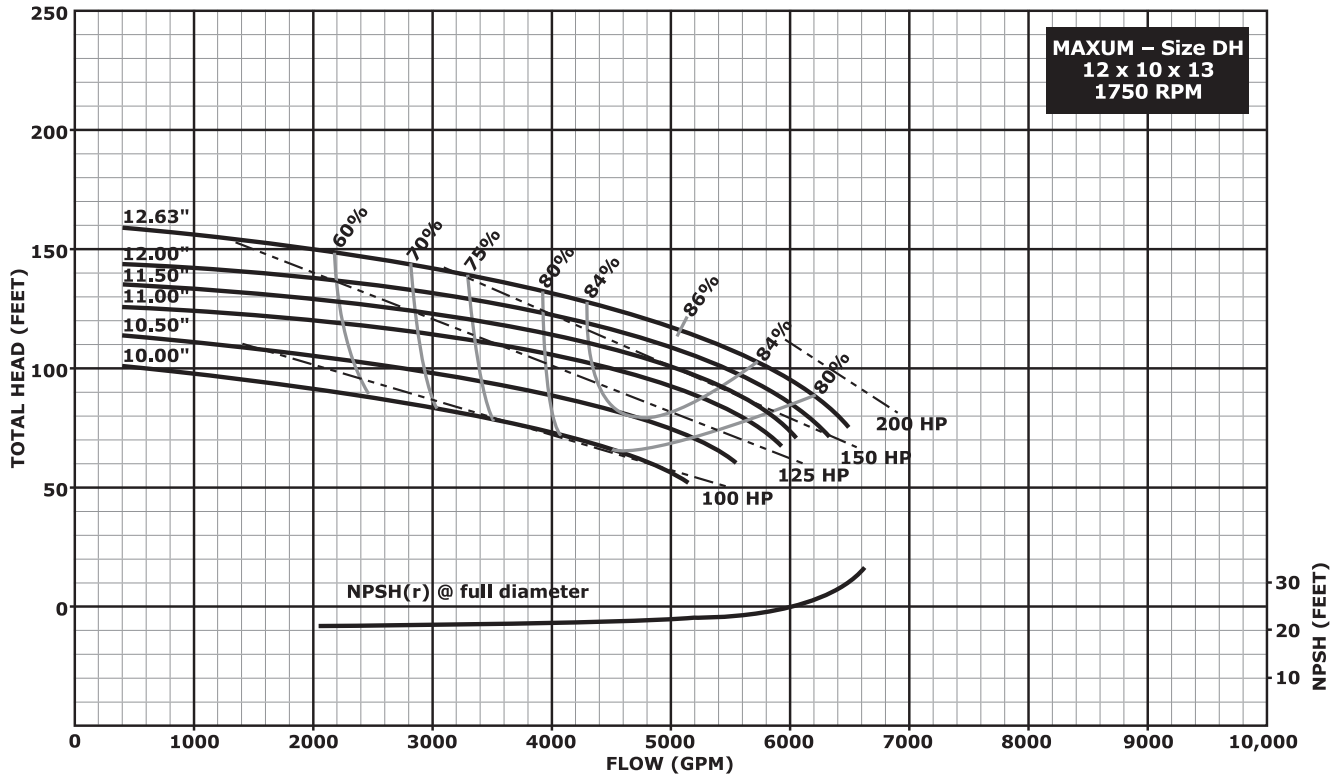

Notes:

1. Above data is based on 1.0 sp. gr. water at ambient temperature and pressure in accordance with Hydraulic Institute guidelines.
2. This is a mixed flow impeller pump, and trimming is accomplished by angular vane cuts. Impeller diameter trims shown are approximations only.

Hydraulic Performance – 16" Impeller Pumps

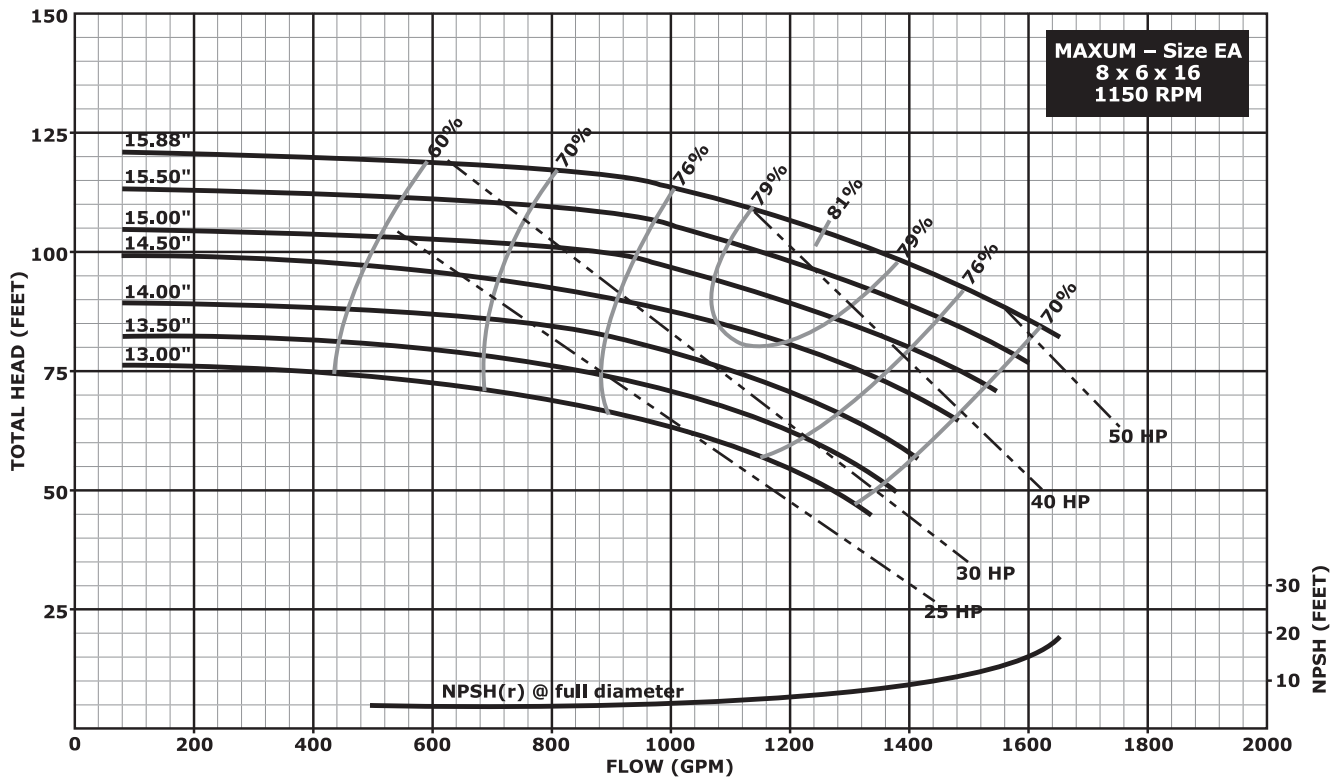
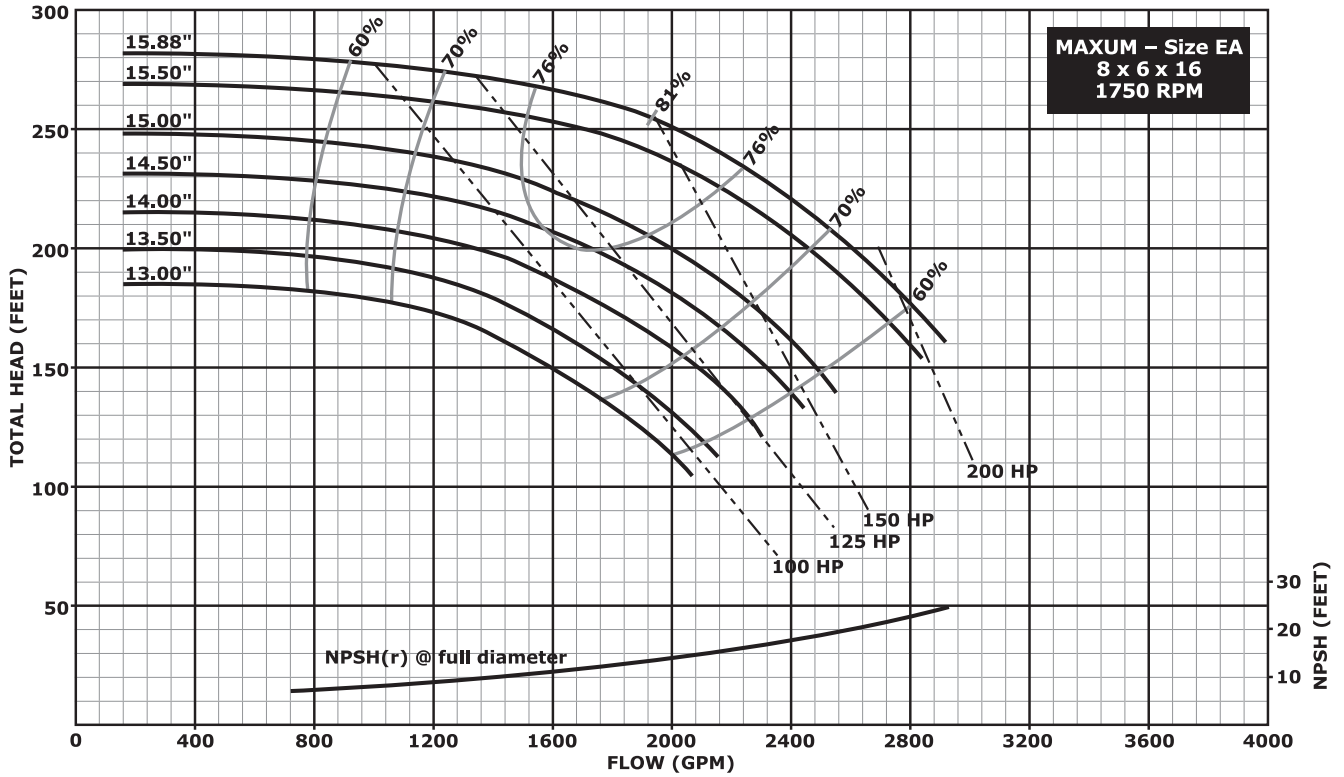

Notes:

1. Above data is based on 1.0 sp. gr. water at ambient temperature and pressure in accordance with Hydraulic Institute guidelines.
2. Impeller diameters between minimum and maximum shown are available in 1/8 inch increment trims.

Hydraulic Performance – 16" Impeller Pumps

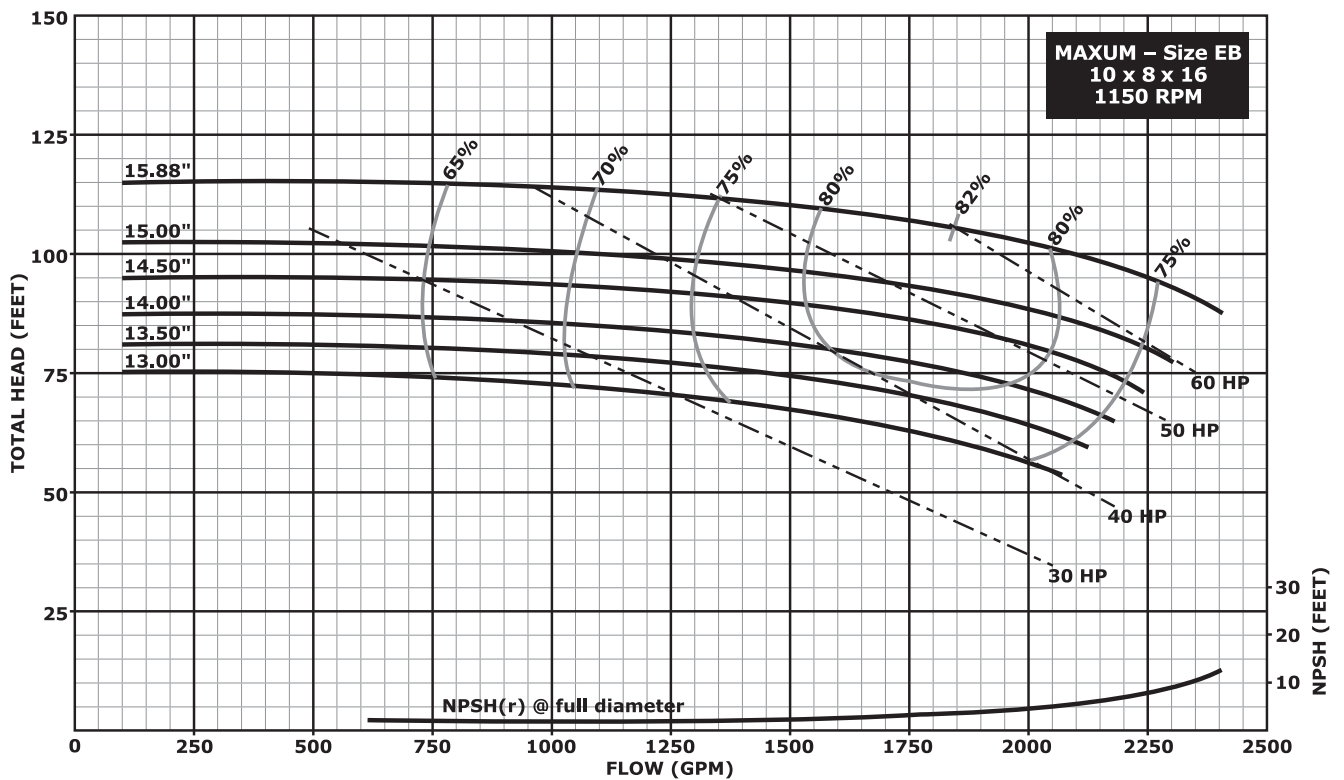
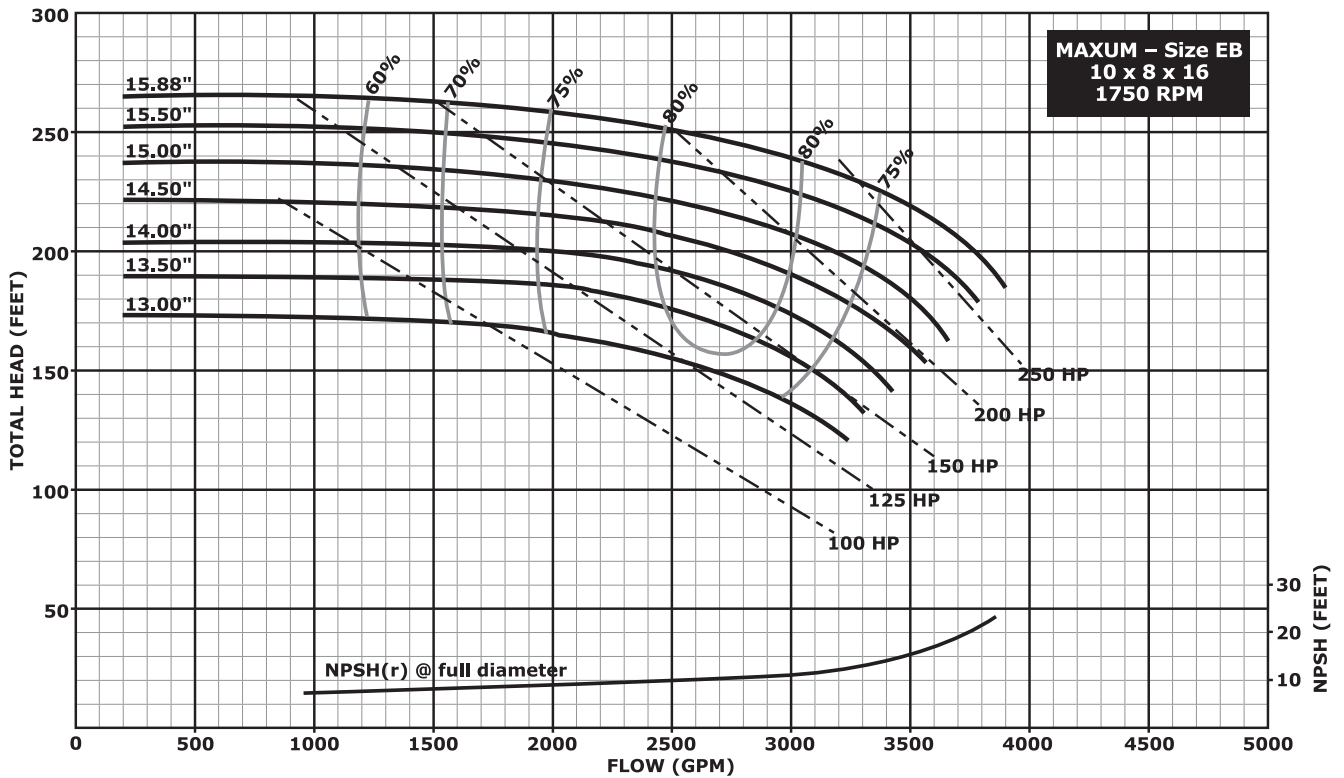

Notes:

1. Above data is based on 1.0 sp. gr. water at ambient temperature and pressure in accordance with Hydraulic Institute guidelines.
2. Impeller diameters between minimum and maximum shown are available in 1/8 inch increment trims.

Hydraulic Performance – 16" Impeller Pumps

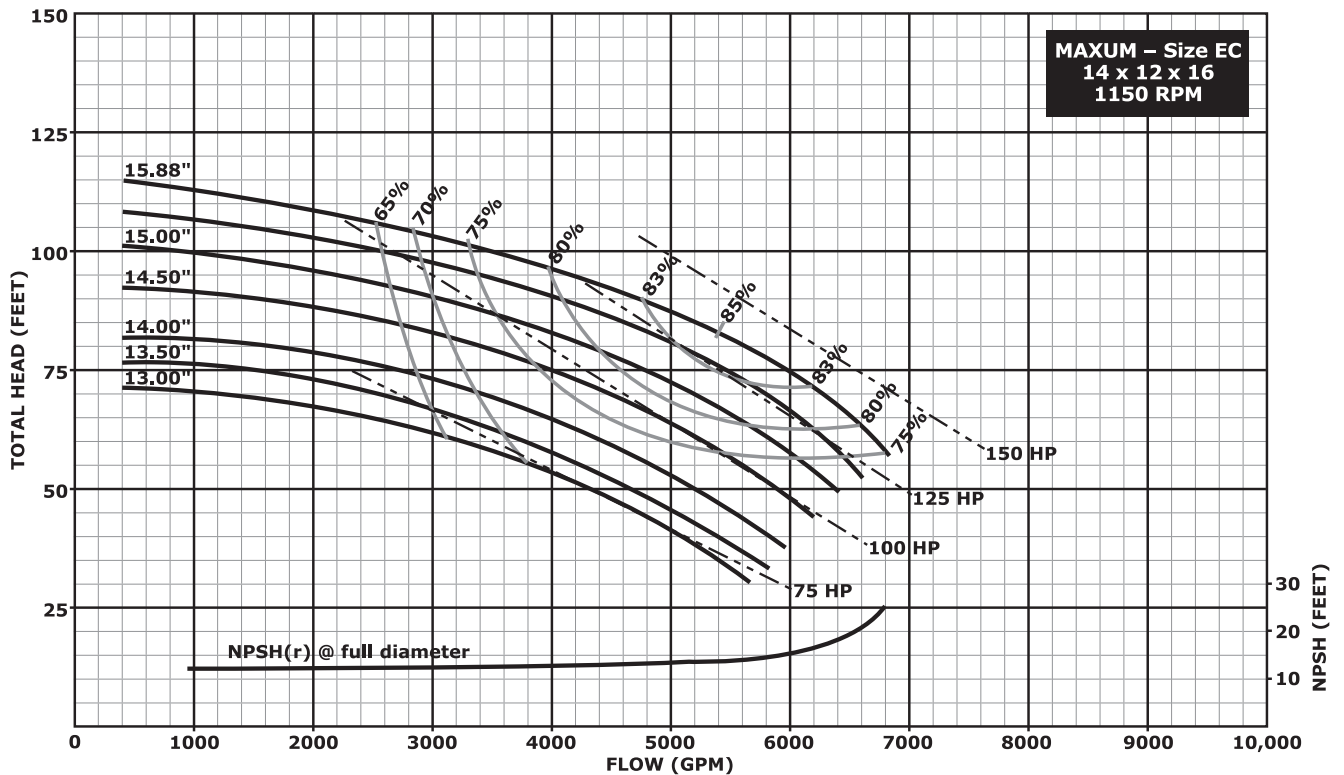
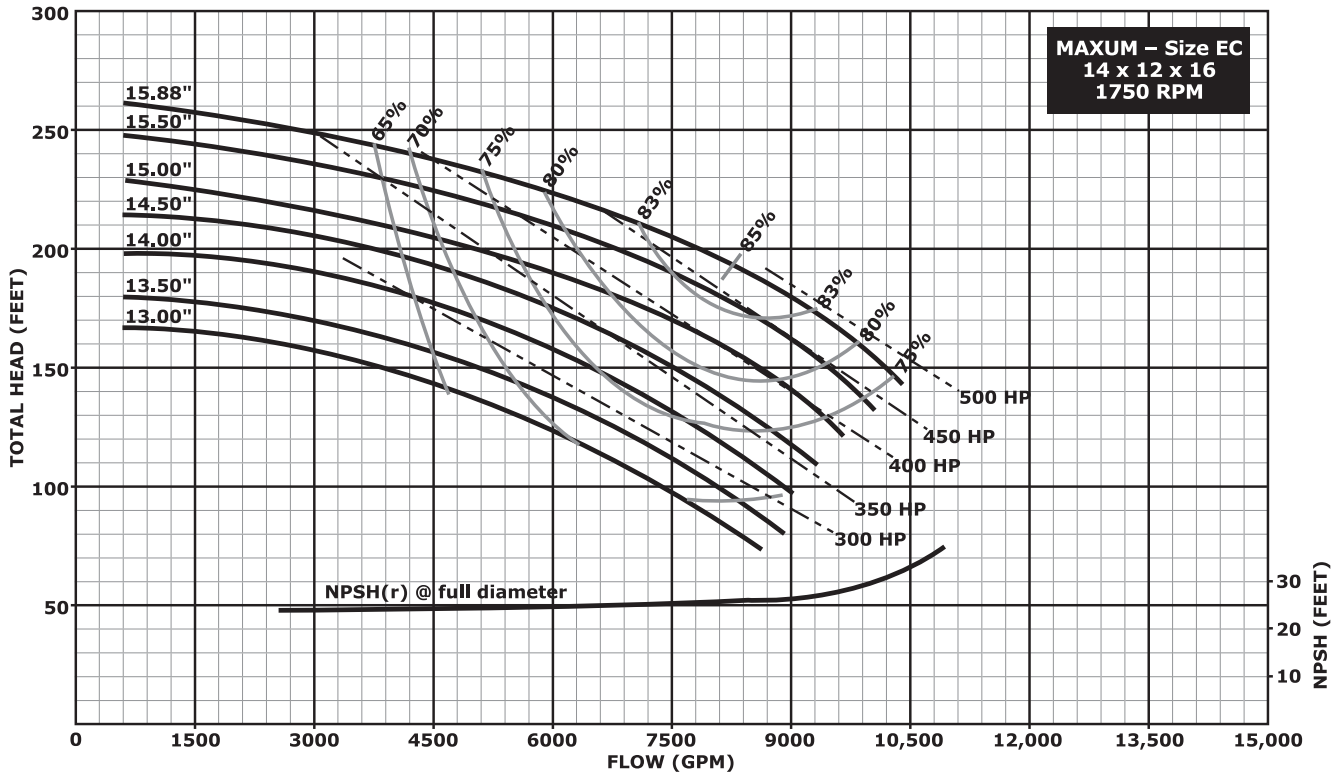

Notes:

1. Above data is based on 1.0 sp. gr. water at ambient temperature and pressure in accordance with Hydraulic Institute guidelines.
2. This is a mixed flow impeller pump, and trimming is accomplished by angular vane cuts. Impeller diameter trims shown are approximations only.

Hydraulic Performance – 20" Impeller Pumps

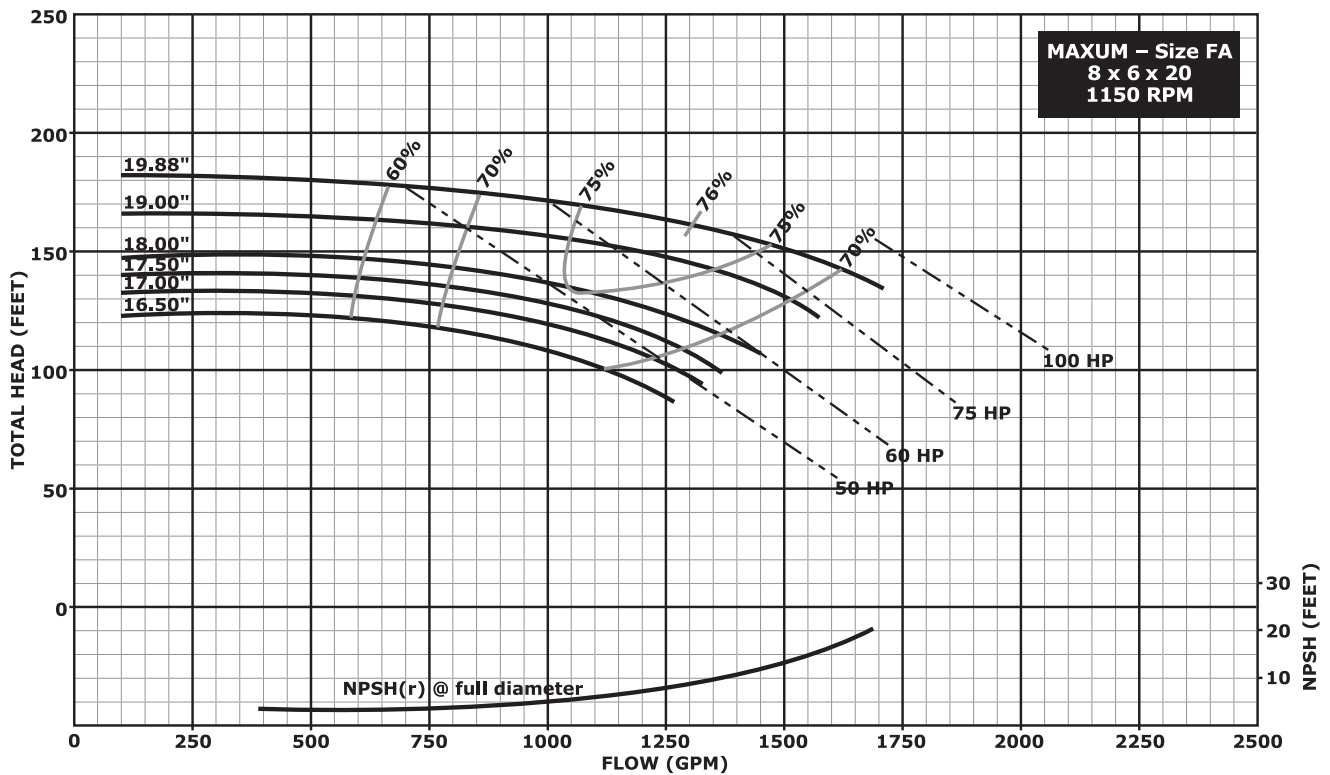
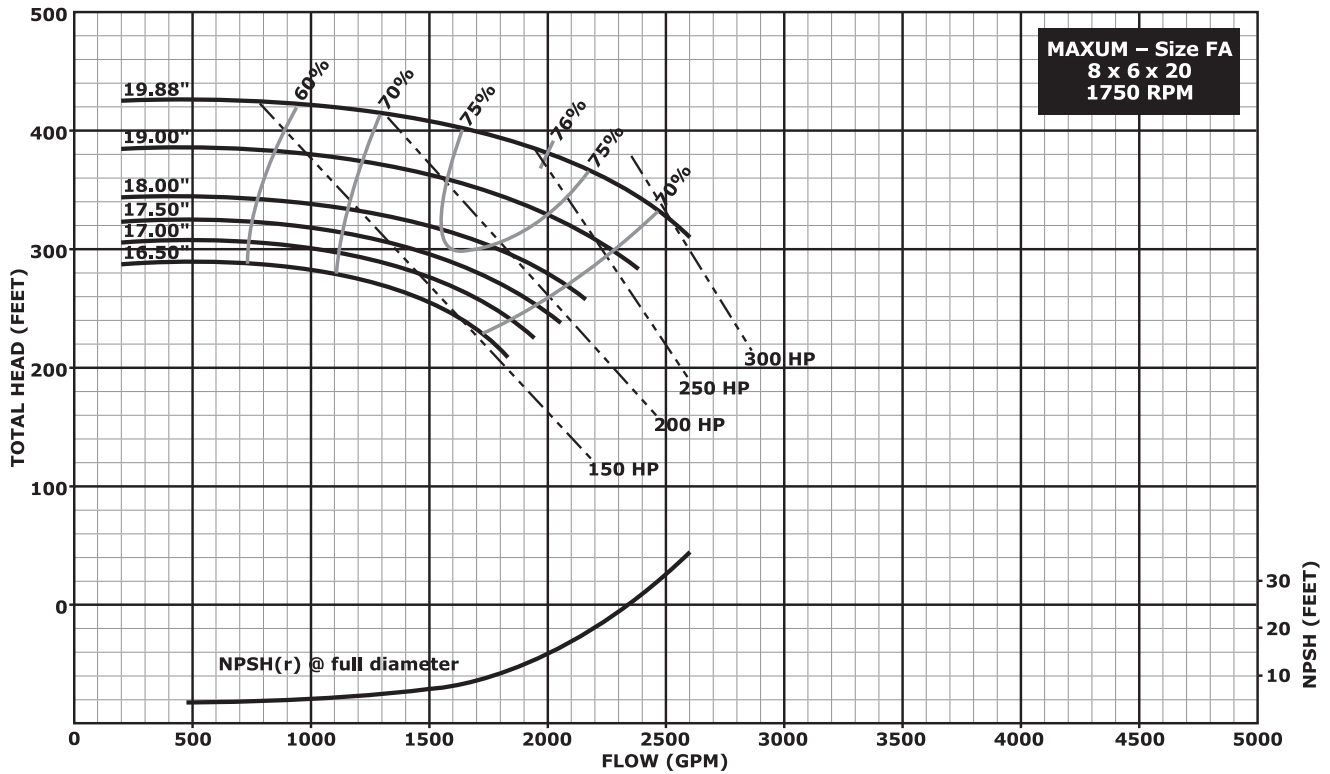

Notes:

1. Above data is based on 1.0 sp. gr. water at ambient temperature and pressure in accordance with Hydraulic Institute guidelines.
2. Impeller diameters between minimum and maximum shown are available in 1/8 inch increment trims.

Hydraulic Performance – 20" Impeller Pumps

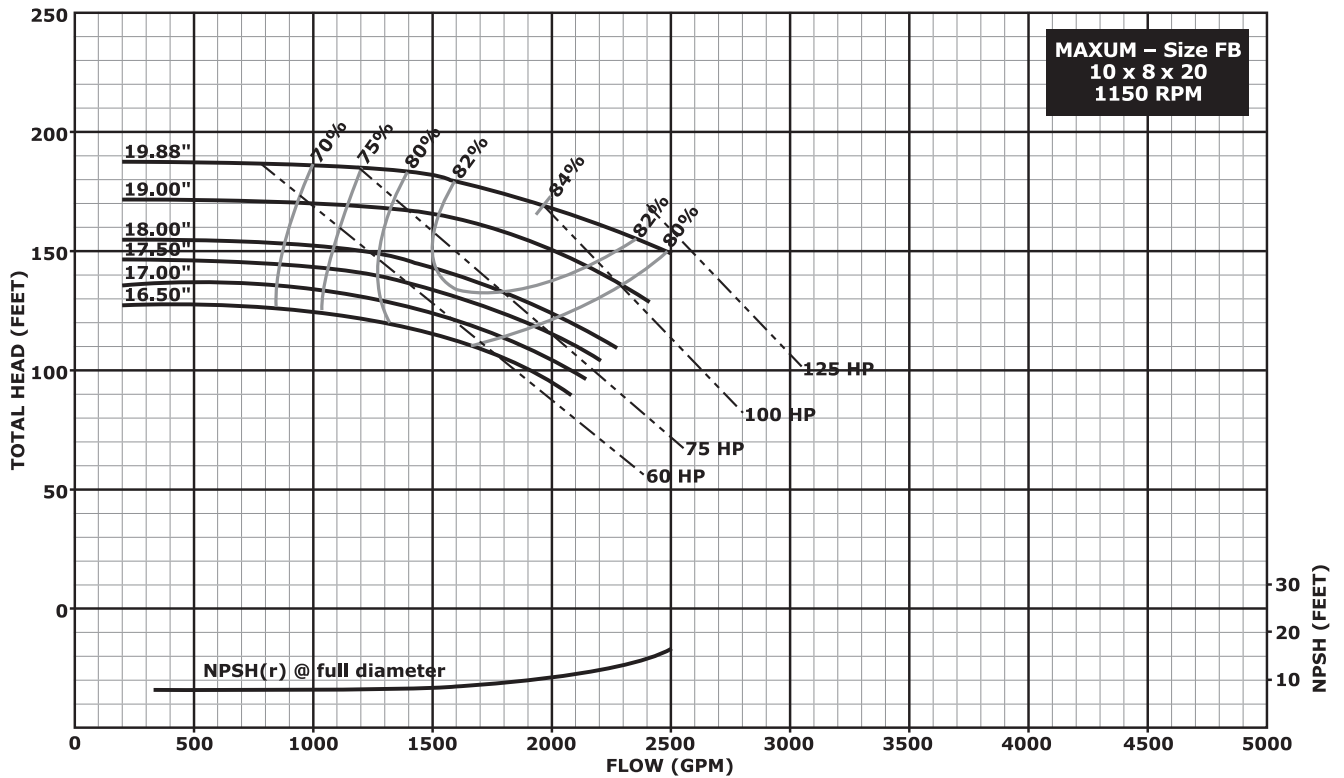
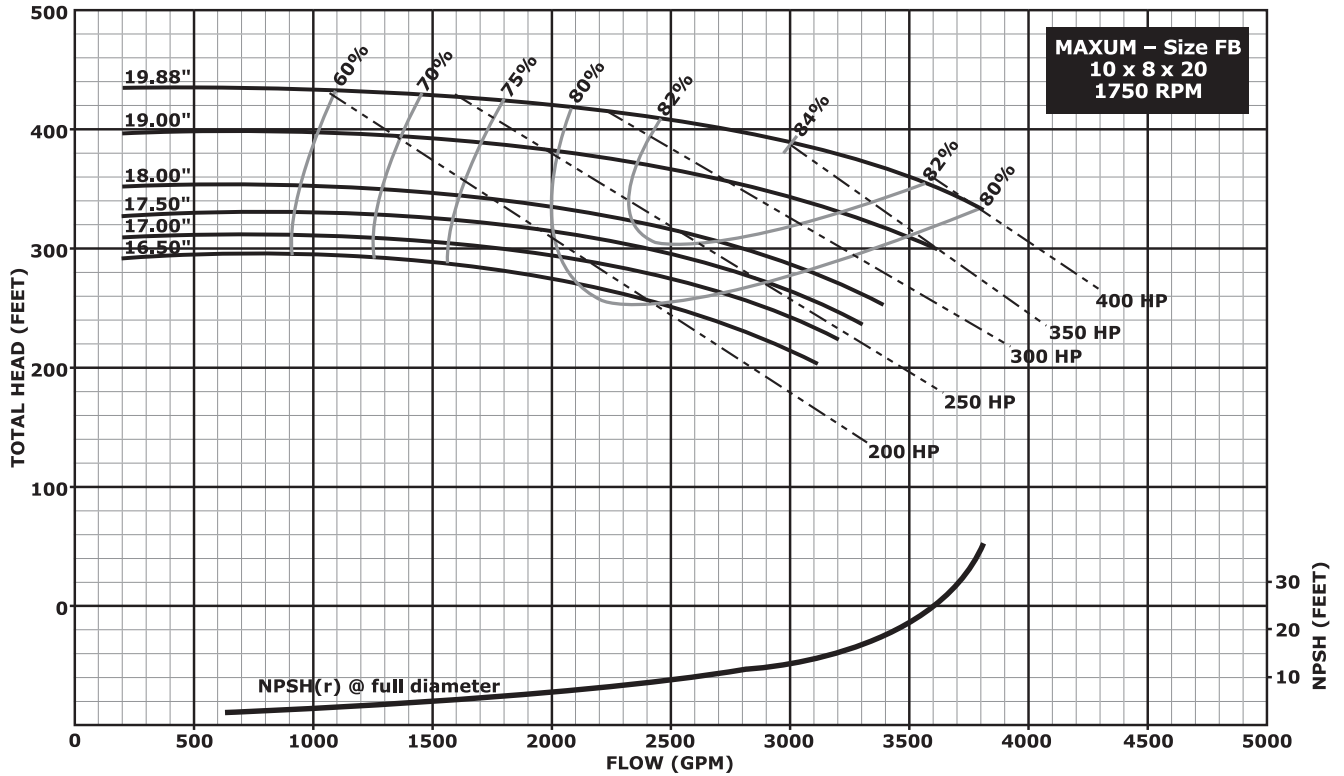

Notes:

1. Above data is based on 1.0 sp. gr. water at ambient temperature and pressure in accordance with Hydraulic Institute guidelines.
2. Impeller diameters between minimum and maximum shown are available in 1/8 inch increment trims.

Hydraulic Performance –20" Impeller Pumps

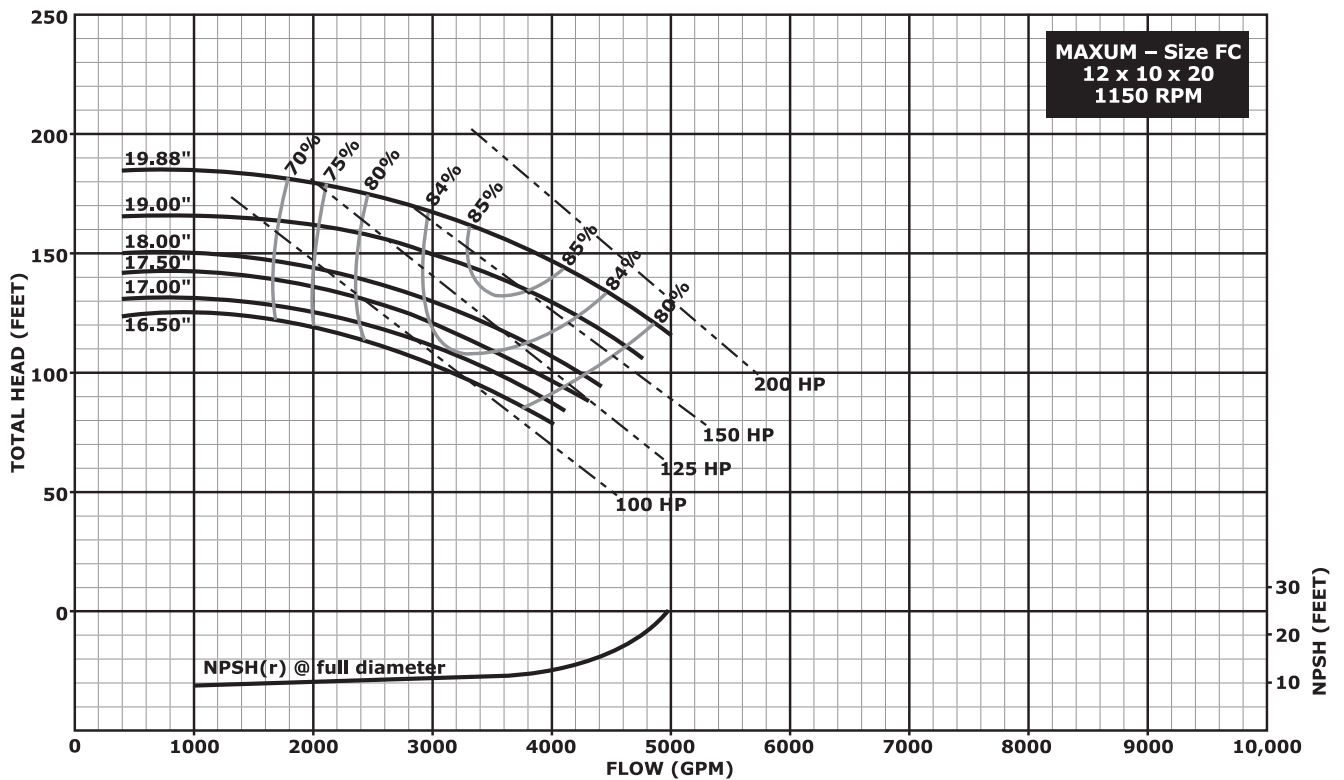
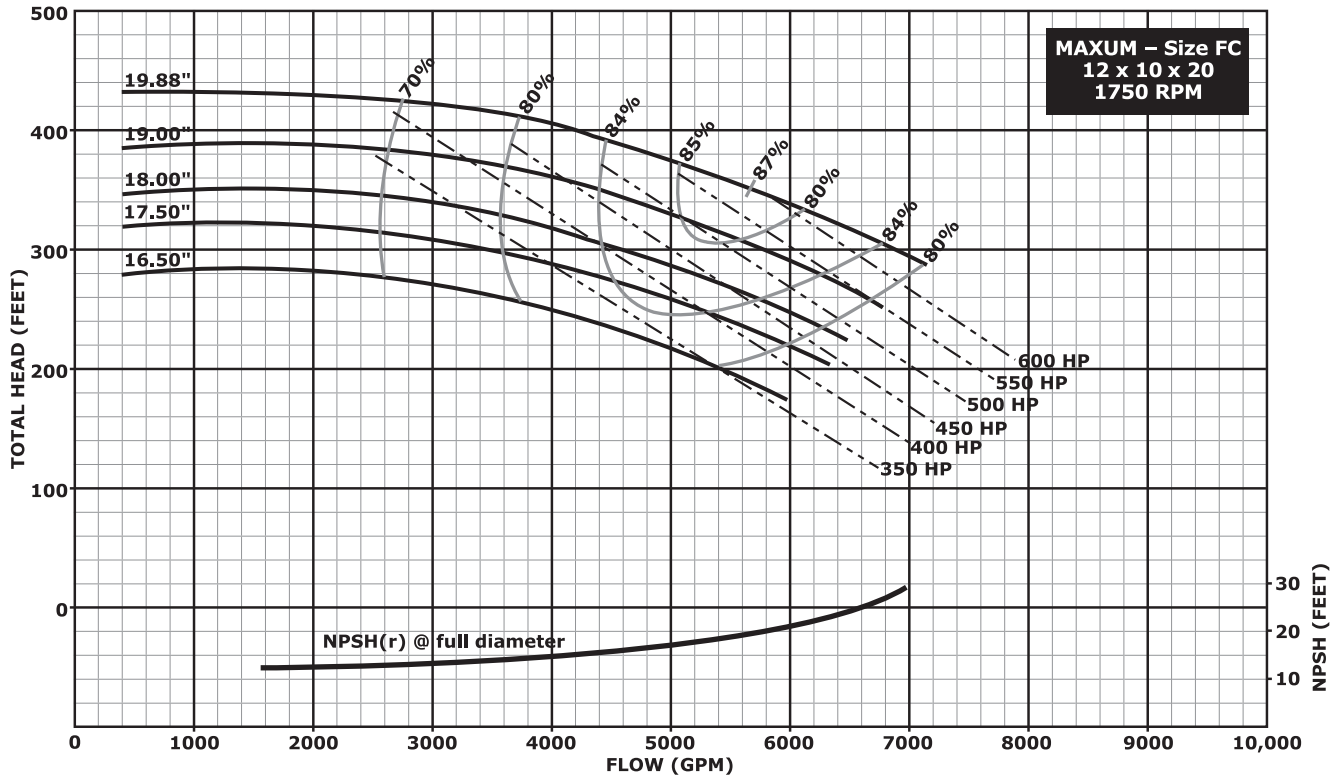

Notes:

1. Above data is based on 1.0 sp. gr. water at ambient temperature and pressure in accordance with Hydraulic Institute guidelines.
2. Impeller diameters between minimum and maximum shown are available in 1/8 inch increment trims.

Hydraulic Performance – 20" Impeller Pumps

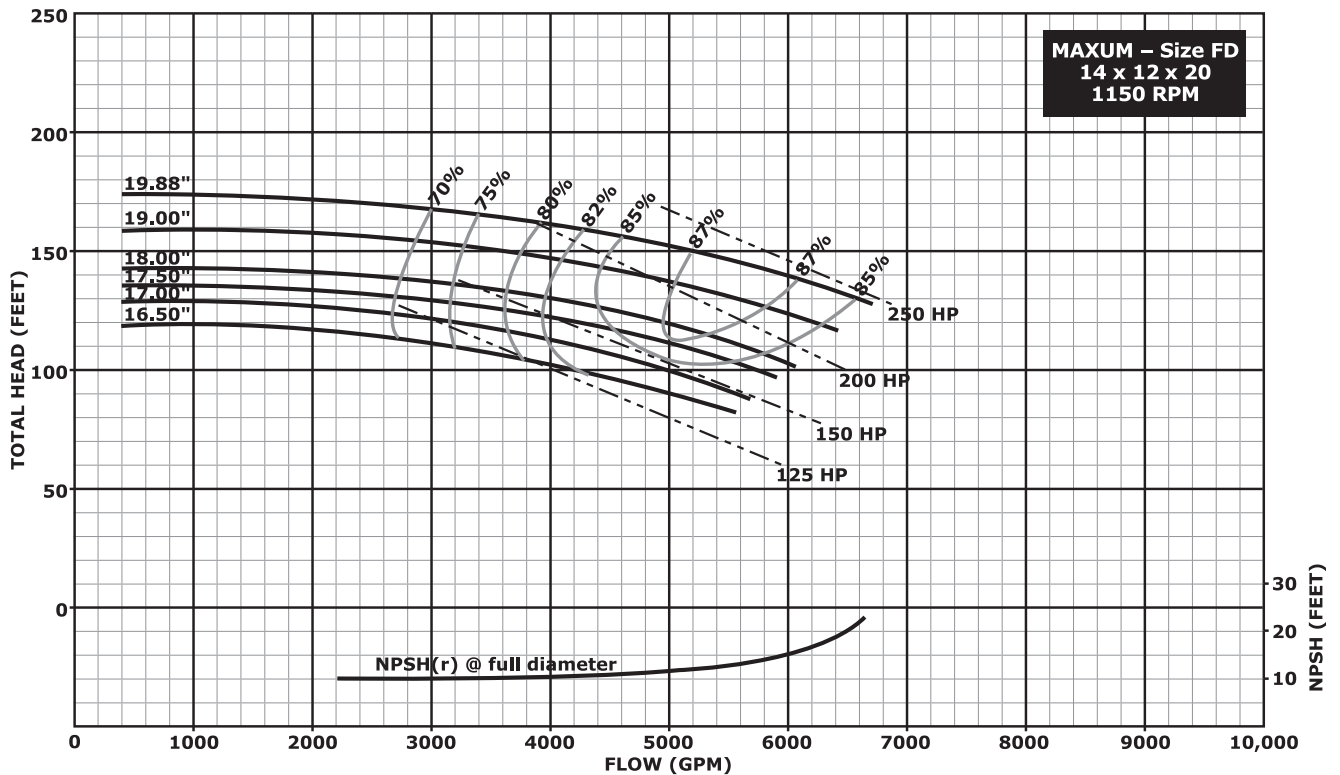
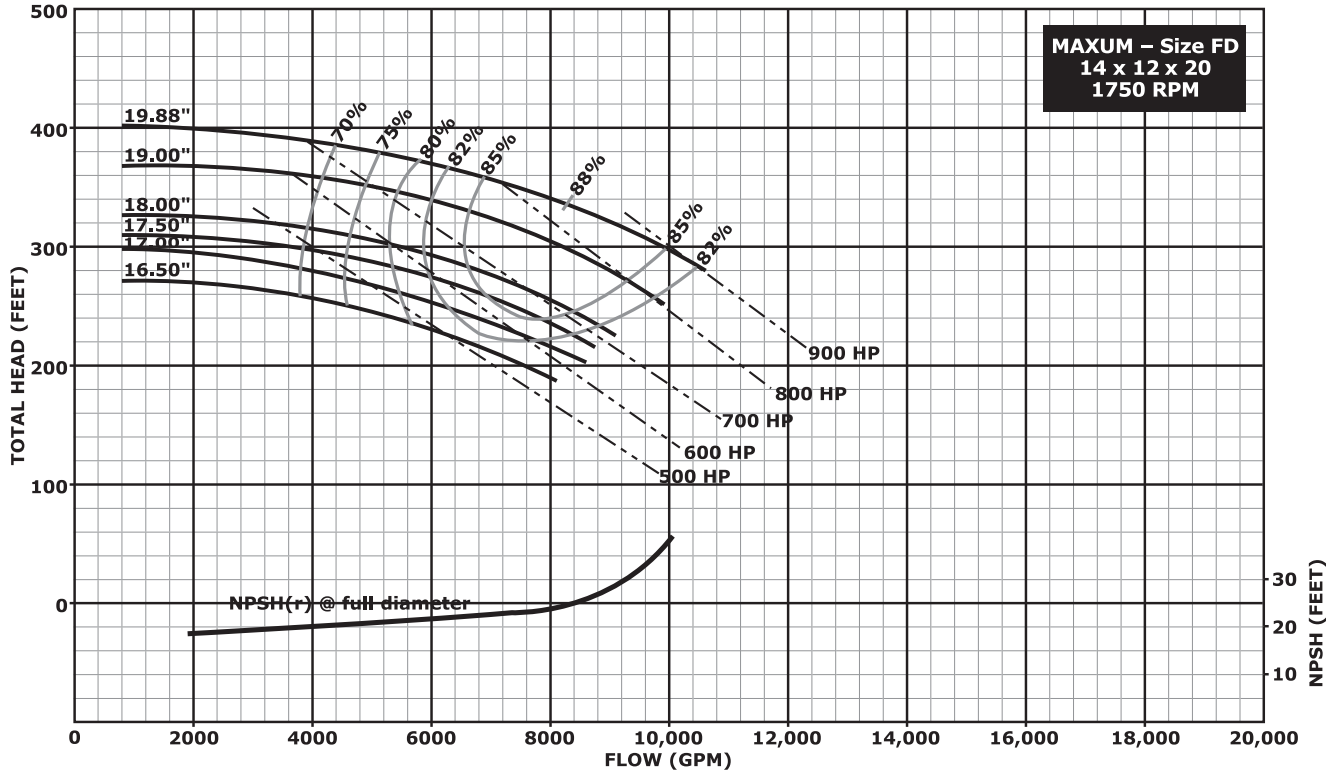

Notes:

1. Above data is based on 1.0 sp. gr. water at ambient temperature and pressure in accordance with Hydraulic Institute guidelines.
2. This is a mixed flow impeller pump, and trimming is accomplished by angular vane cuts. Impeller diameter trims shown are approximations only.

Permissible Nozzle Loads

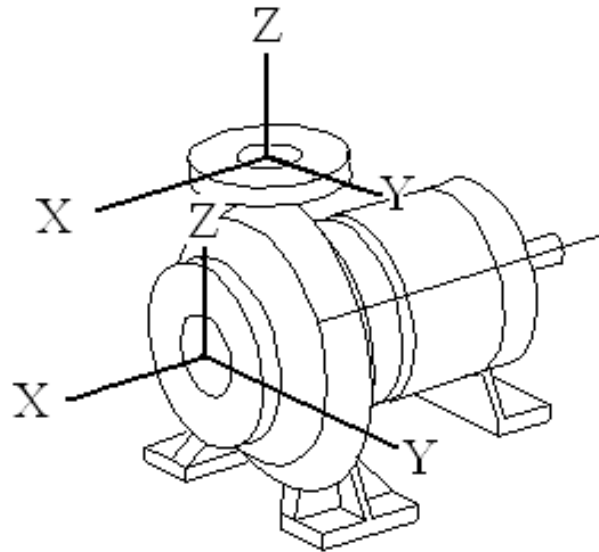

Pump Size	Suction						Discharge					
	Fx	Fy	Fz	Mx	My	Mz	Fx	Fy	Fz	Mx	My	Mz
AA - 1½ x 1 x 6	600	450	900	430	600	260	600	400	1,200	430	600	260
AB - 2 x 1½ x 6	1,010	760	1,500	680	960	340	890	650	2,000	680	960	340
AC - 3 x 1½ x 6	1,260	950	1,900	860	960	530	1,240	810	2,500	860	1,200	420
AD - 3 x 2 x 6	1,260	920	1,800	860	960	530	1,240	720	2,500	860	1,200	420
AE - 4 x 3 x 6	1,260	890	1,790	980	850	740	970	650	2,500	860	1,100	530
BA - 1½ x 1 x 8	1,820	650	1,120	770	820	390	600	660	1,600	770	820	390
BB - 2 x 1½ x 8	1,820	650	1,120	770	820	390	600	660	1,600	770	820	390
BC - 3 x 1½ x 8	1,260	740	1,440	930	990	530	800	750	2,000	930	990	460
BD - 3 x 2 x 8	1,260	930	1,800	1,160	1,240	580	1,000	940	2,500	1,160	1,240	580
BE - 4 x 3 x 8	1,260	870	1,750	1,150	1,080	740	860	770	2,500	1,150	1,280	570
BF - 6 x 4 x 8	2,000	1,440	2,800	1,850	920	1,300	830	1,170	4,000	1,850	1,300	920
CA - 2 x 1½ x 10	820	600	1,200	670	890	340	750	510	1,650	670	890	340
CB - 3 x 1½ x 10	1,260	900	1,810	1,020	1,350	530	1,020	770	2,500	1,020	1,350	510
CC - 3 x 2 x 10	1,260	900	1,810	1,020	1,350	530	1,020	770	2,500	1,020	1,350	510
CD - 4 x 3 x 10	1,480	1,420	2,800	2,600	1,350	1,320	670	1,300	4,000	2,600	1,350	1,320
CE - 6 x 4 x 10	1,240	1,100	2,200	2,080	1,140	1,300	540	980	3,200	2,080	1,140	1,050
CF - 6 x 6 x 10	1,560	1,380	2,750	2,600	1,430	1,320	670	1,230	4,000	2,600	1,430	1,320
CG - 8 x 6 x 10	1,560	1,380	2,750	2,600	1,300	1,900	670	1,230	4,000	2,600	1,430	1,320
DA - 2 x 1½ x 13	1,000	720	1,440	420	1,040	460	630	550	2,000	920	1,040	460
DB - 3 x 2 x 13	1,260	900	1,800	1,150	1,300	570	790	690	2,500	1,150	1,300	570
DC - 4 x 3 x 13	1,650	1,400	2,800	2,350	1,340	1,170	730	1,270	4,000	2,350	1,340	1,170
DD - 6 x 4 x 13	1,650	1,400	2,800	2,350	1,040	1,300	730	1,270	4,000	2,350	1,340	1,170
DE - 6 x 6 x 13	2,500	2,150	4,300	4,500	2,950	2,250	1,050	1,600	6,000	4,500	2,950	2,250
DF - 8 x 6 x 13	2,500	2,150	4,300	4,500	2,950	2,250	1,050	1,600	6,000	4,500	2,950	2,250
DG - 10 x 8 x 13	2,500	2,150	4,300	4,500	1,950	2,800	1,050	1,600	6,000	4,500	2,950	2,250
DH - 12 x 10 x 13	2,400	2,760	5,500	8,660	3,220	4,330	1,200	2,500	8,660	8,660	3,220	4,330
EA - 8 x 6 x 16	2,500	2,150	4,300	4,500	2,950	2,250	1,050	1,600	6,000	4,500	2,950	2,250
EB - 10 x 8 x 16	2,500	2,150	4,300	4,500	1,950	2,800	1,050	1,600	6,000	4,500	2,950	2,250
EC - 14 x 12 x 16	2,920	3,960	7,930	14,170	4,870	7,080	1,500	2,700	11,340	14,170	4,870	7,080
FA - 8 x 6 x 20	1,480	2,200	4,400	4,700	1,850	2,350	640	1,620	6,260	4,700	1,850	2,350
FB - 10 x 8 x 20	1,360	2,450	4,300	5,740	1,880	2,870	850	1,780	6,260	5,740	1,880	2,870
FC - 12 x 10 x 20	3,160	2,450	4,900	7,300	4,900	3,650	1,300	1,940	6,260	7,300	4,900	3,650
FD - 14 x 12 x 20	2,750	4,000	8,020	17,010	5,040	8,500	1,500	3,500	11,340	17,010	5,040	8,500



1. All force values in lbs. All moment values in ft.-lbs.
2. All moment values in ft.-lbs.
3. Not valid for construction unless certified.

Dwg: SP-MAX-1, Rev: 0

Stuffing Box Dimensions for "A" Bearing Frames

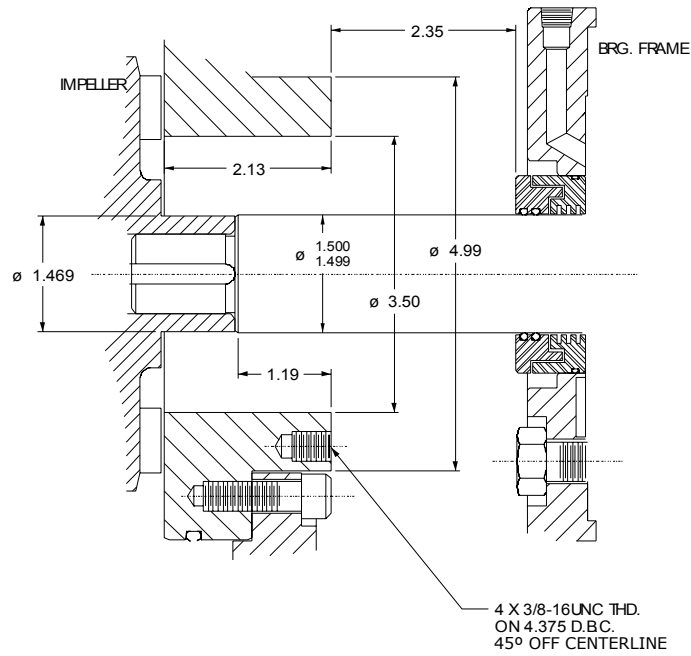

Sizes 1½ x 1 x 6, 3 x 2½ x 6, and 3 x 1½ x 6

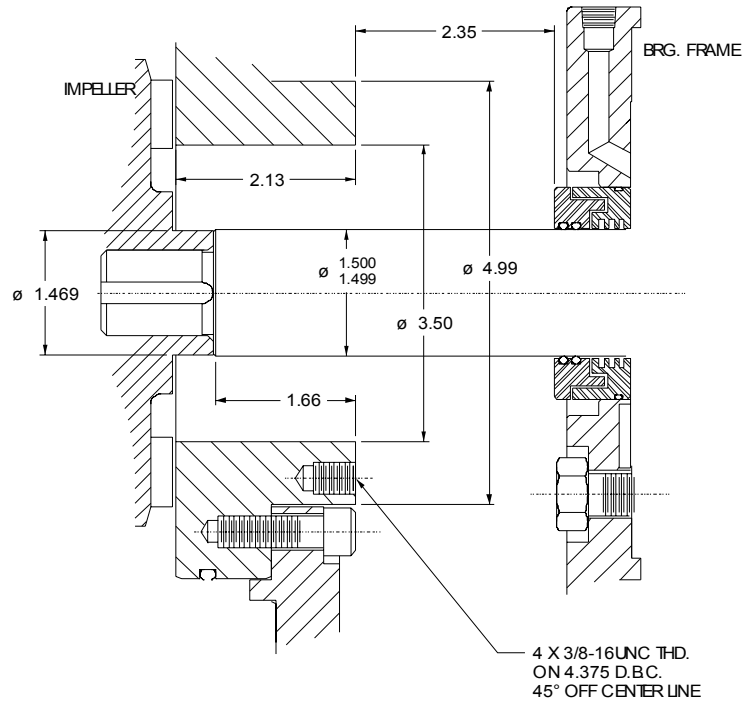

Sizes 3 x 2 x 6 and 4 x 3 x 6



1. All dimensions in inches unless otherwise noted.
2. All tolerances +/- 0.010 inch.
3. Not valid for construction unless certified.

Dwg: SP-MAX-2, Rev: 0

Stuffing Box Dimensions for "B", "C", and "D" Bearing Frames

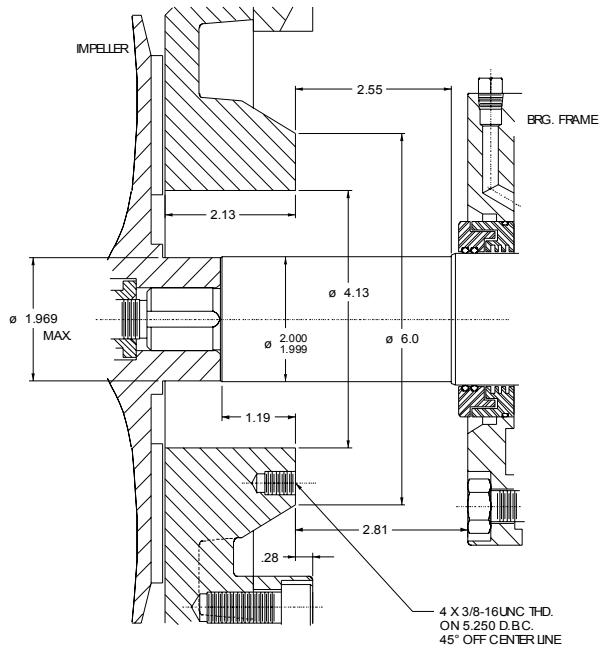

Maxum "B" Bearing Frame

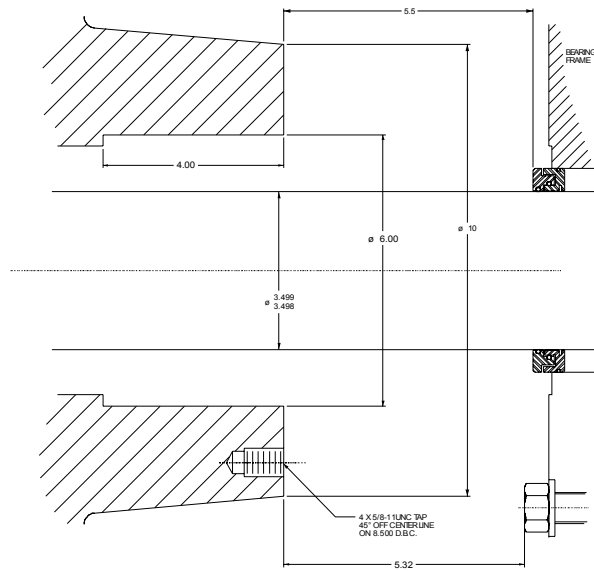

Maxum "D" Bearing Frame

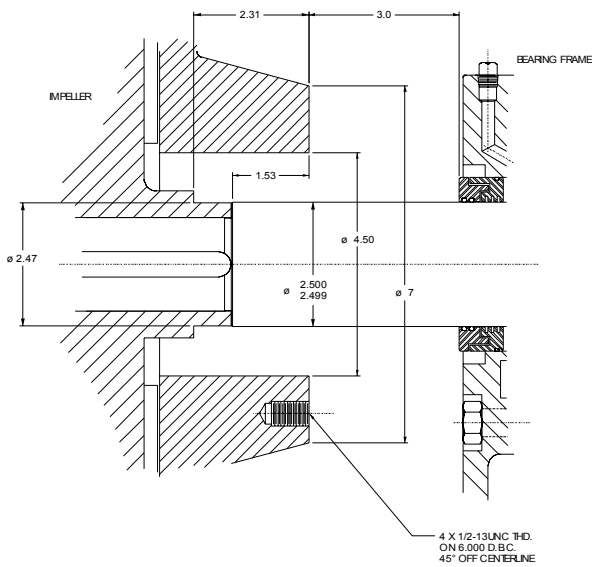

Maxum "C" Bearing Frame



1. All dimensions in inches unless otherwise noted.
2. All tolerances +/- 0.010 inch.
3. Not valid for construction unless certified.

Dwg: SP-MAX-3, Rev: 0

Foot Mounted Pump Dimensions

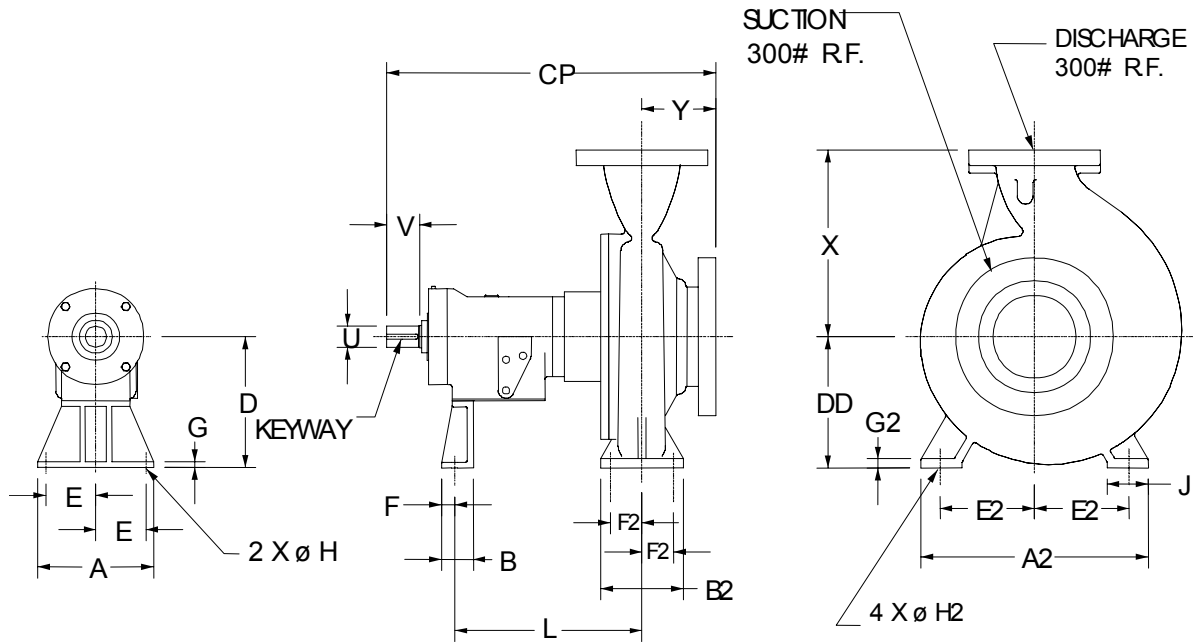

Pump Size	Pump Dimensions																					
	X	Y	CP	A	A2	B	B2	D	DD	E	E2	F	F2	G	G2	H	H2	J	L	U	V	Keyway
1½ x 1 x 6	6.50	4.00	22.3	8.25	5.25	2.00	4.00	5.94	6.00	3.50	4.19	0.69	1.38	0.44	0.75	0.63	0.63	2.25	12.0	1.13	3.00	0.25 x 0.125
2 x 1½ x 6	6.50	4.00	22.4	8.25	5.25	2.00	4.00	5.94	6.00	3.50	4.19	0.69	1.38	0.44	0.75	0.63	0.63	2.25	12.1	1.13	3.00	0.25 x 0.125
3 x 1½ x 6	6.50	4.00	22.4	8.25	5.25	2.00	4.00	5.94	6.00	3.50	4.19	0.69	1.38	0.44	0.75	0.63	0.63	2.25	12.1	1.13	3.00	0.25 x 0.125
3 x 2 x 6	8.25	4.00	22.4	8.25	5.25	2.00	4.00	5.94	6.00	3.50	4.19	0.69	1.38	0.44	0.75	0.63	0.63	2.25	12.1	1.13	3.00	0.25 x 0.125
4 x 3 x 6	11.0	5.13	23.8	8.25	5.25	2.00	4.00	6.94	7.00	3.50	4.38	0.69	1.38	0.44	0.75	0.63	0.63	2.25	12.4	1.13	3.00	0.25 x 0.125
1½ x 1 x 8	6.50	4.00	23.1	8.25	12.6	2.00	6.00	6.94	7.00	3.50	5.56	0.69	2.25	0.44	0.75	0.63	0.63	2.56	12.7	1.38	3.00	0.31 x 0.156
2 x 1½ x 8	6.50	4.00	23.2	8.25	12.6	2.00	6.00	6.94	7.00	3.50	5.56	0.69	2.25	0.44	0.75	0.63	0.63	2.56	12.8	1.38	3.00	0.31 x 0.156
3 x 1½ x 8	8.50	4.00	23.2	8.25	12.6	2.00	6.00	6.94	7.00	3.50	5.56	0.69	2.25	0.44	0.75	0.63	0.63	2.56	12.8	1.38	3.00	0.31 x 0.156
3 x 2 x 8	9.50	4.00	23.2	8.25	12.6	2.00	6.00	6.94	7.00	3.50	5.56	0.69	2.25	0.44	0.75	0.63	0.63	2.56	12.8	1.38	3.00	0.31 x 0.156
4 x 3 x 8	11.0	4.00	23.4	8.25	14.0	2.00	5.50	7.81	7.88	3.50	5.50	0.69	1.88	0.44	0.75	0.63	0.63	3.25	13.0	1.38	3.00	0.31 x 0.156
6 x 4 x 8	11.3	5.50	25.2	8.25	14.0	2.00	6.00	7.81	7.88	3.50	5.50	0.69	2.38	0.44	0.75	0.63	0.75	3.25	13.3	1.38	3.00	0.31 x 0.156
2 x 1½ x 10	9.06	4.13	23.5	8.25	12.6	2.00	4.88	6.94	7.00	3.50	5.00	0.69	1.50	0.44	0.69	0.63	0.63	2.56	12.9	1.38	3.00	0.31 x 0.156
3 x 1½ x 10	8.88	5.00	24.2	8.25	12.3	2.00	5.00	6.94	7.00	3.50	4.88	0.69	1.88	0.44	0.75	0.63	0.63	2.50	12.9	1.38	3.00	0.31 x 0.156
3 x 2 x 10	9.50	4.00	23.2	8.25	12.3	2.00	5.00	6.94	7.00	3.50	4.88	0.69	1.38	0.44	0.75	0.63	0.63	2.50	12.8	1.38	3.00	0.31 x 0.156
4 x 3 x 10	10.5	5.25	24.6	9.50	15.8	2.00	6.25	8.81	8.88	3.50	6.25	0.69	2.38	0.44	0.75	0.63	0.75	3.18	12.9	1.38	3.00	0.31 x 0.156
6 x 4 x 10	11.5	5.88	25.4	9.50	15.8	2.00	6.00	8.81	8.88	3.50	6.25	0.69	2.38	0.44	0.75	0.63	0.75	3.18	13.0	1.38	3.00	0.31 x 0.156
6 x 6 x 10	15.1	6.88	26.5	9.50	20.0	2.00	8.00	10.9	11.0	3.50	7.88	0.69	2.94	0.44	1.00	0.63	0.75	4.00	13.3	1.38	3.00	0.31 x 0.156
8 x 6 x 10	15.0	6.63	26.6	9.50	20.0	2.00	7.88	10.9	11.0	3.50	7.88	0.69	2.94	0.44	1.13	0.63	0.75	4.00	13.6	1.38	3.00	0.31 x 0.156
2 x 1½ x 13	10.0	5.00	28.5	11.0	13.5	3.00	5.00	7.81	7.88	4.75	5.50	1.25	1.88	0.56	0.75	0.63	0.63	2.56	17.0	2.00	3.00	0.50 x 0.250
3 x 2 x 13	11.0	5.10	28.6	11.0	13.5	3.00	5.00	8.81	8.88	4.75	5.50	1.25	1.88	0.56	0.75	0.63	0.63	2.56	17.0	2.00	3.00	0.50 x 0.250
4 x 3 x 13	12.5	5.50	29.1	11.0	16.5	3.00	6.25	9.69	9.75	4.75	7.00	1.25	2.38	0.56	0.88	0.63	0.75	3.13	17.2	2.00	3.00	0.50 x 0.250
6 x 4 x 13	12.8	6.00	29.8	11.0	16.5	3.00	6.25	9.69	9.75	4.75	7.00	1.25	2.38	0.56	0.88	0.63	0.75	3.13	17.4	2.00	3.00	0.50 x 0.250
6 x 6 x 13	16.1	7.52	31.4	11.0	21.5	3.00	8.00	12.4	12.6	4.75	8.88	1.25	2.94	0.56	1.00	0.63	0.88	4.13	17.4	2.00	3.00	0.50 x 0.250
8 x 6 x 13	16.3	6.75	31.0	11.0	21.5	3.00	8.00	12.4	12.6	4.75	8.88	1.25	2.94	0.56	1.00	0.63	0.88	4.13	17.8	2.00	3.00	0.50 x 0.250
10 x 8 x 13	18.5	8.50	32.9	11.0	22.0	3.00	8.00	13.9	14.0	4.75	9.00	1.25	3.00	0.56	1.00	0.63	0.88	4.00	18.0	2.00	3.00	0.50 x 0.250
12 x 10 x 13	22.5	10.5	35.5	11.0	28.0	3.00	10.0	15.9	16.0	4.75	12.0	1.25	3.50	0.56	1.13	0.63	1.00	5.00	18.5	2.00	3.00	0.50 x 0.250
8 x 6 x 16	17.8	7.00	31.3	11.0	10.8	3.00	7.88	12.4	12.5	4.75	9.00	1.25	3.00	0.56	0.88	0.63	0.88	3.94	17.8	2.00	3.00	0.50 x 0.250
10 x 8 x 16	20.3	7.50	31.9	11.0	11.0	3.00	8.00	13.9	14.0	4.75	9.00	1.25	3.00	0.56	1.00	0.63	0.88	4.00	17.9	2.00	3.00	0.50 x 0.250
14 x 12 x 16	26.0	12.0	52.0	11.0	17.8	3.00	14.2	19.9	20.0	4.75	15.0	1.50	5.00	0.63	1.25	0.75	1.06	7.00	27.9	3.00	5.75	0.75 x 0.375
8 x 6 x 20	19.8	7.25	31.2	11.0	10.9	3.00	8.00	14.9	15.0	4.75	9.00	1.50	3.00	0.56	1.13	0.63	0.88	4.00	17.1	2.00	3.00	0.50 x 0.250
10 x 8 x 20	22.0	7.88	32.0	11.0	13.0	3.00	7.88	16.6	16.6	4.75	11.0	1.50	3.00	0.56	0.63	0.63	0.88	4.00	17.4	2.00	3.00	0.50 x 0.250
12 x 10 x 20	26.4	7.88	47.8	12.0	15.8	3.00	10.3	18.6	18.7	5.00	14.0	1.00	3.75	0.63	1.00	0.75	0.88	5.13	28.3	3.00	5.75	0.75 x 0.375
14 x 12 x 20	29.6	12.0	52.5	12.0	21.3	3.00	14.8	21.9	22.0	5.00	18.0	1.00	5.00	0.63	1.98	0.75	1.06	10.0	29.0	3.00	5.75	0.75 x 0.375



1. All dimensions in inches, unless otherwise noted.
2. All tolerances +/- 0.125 inch.
3. Not valid for construction unless certified.

Dwg: SP-MAX-4, Rev: 0

Centerline Mounted Pump Dimensions

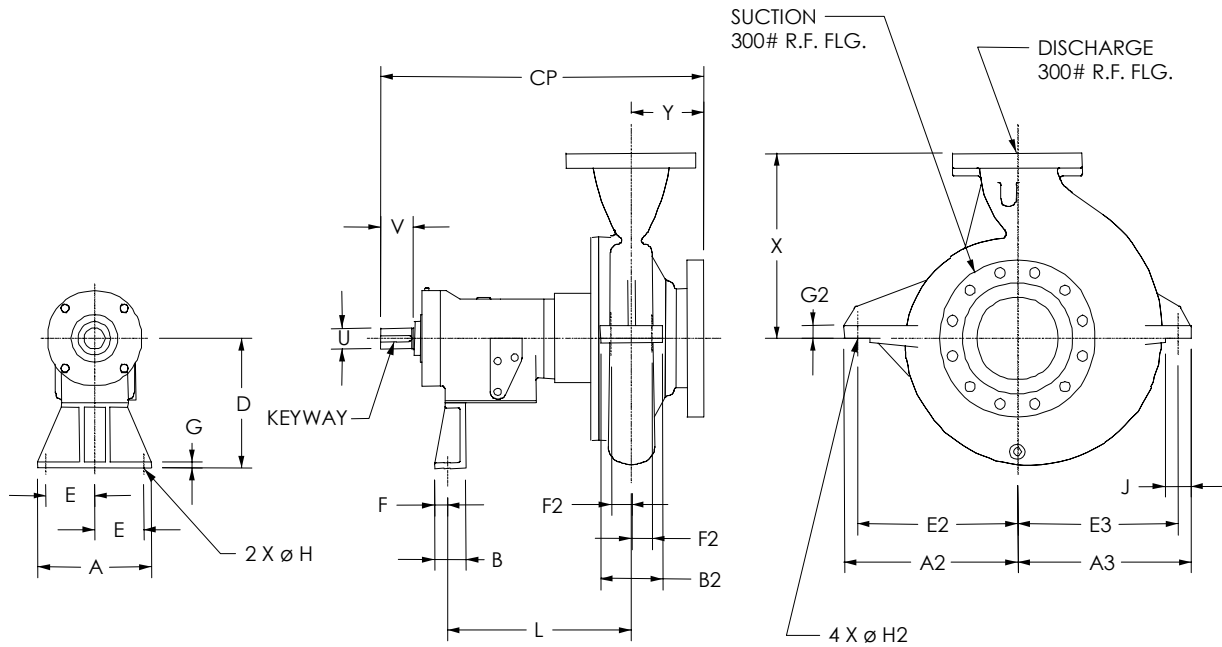

Dimension "B" = 2.00" for 6" through 10" impeller pumps and 3.00" for all other sizes

Pump Size	Pump Dimensions																					
	X	Y	CP	A	A2	A3	B2	D	E	E2	E3	F	F2	G	G2	H	H2	J	L	U	V	Keyway
1½ x 1 x 6	6.50	4.00	22.4	8.25	8.12	8.13	4.50	5.94	3.50	7.25	7.25	0.69	1.50	0.44	1.50	0.63	0.75	2.00	12.00	1.13	3.00	0.25 x 0.125
2 x 1½ x 6	6.50	4.00	22.5	8.25	8.12	8.13	4.50	5.94	3.50	7.25	7.25	0.69	1.50	0.44	1.50	0.63	0.75	2.00	12.13	1.13	3.00	0.25 x 0.125
3 x 1½ x 6	6.50	4.00	22.5	8.25	8.12	8.13	4.50	5.94	3.50	7.25	7.25	0.69	1.50	0.44	1.50	0.63	0.75	2.00	12.13	1.13	3.00	0.25 x 0.125
3 x 2 x 6	8.25	4.00	22.5	8.25	8.12	8.13	4.50	5.94	3.50	7.25	7.25	0.69	1.50	0.44	1.50	0.63	0.75	2.00	12.13	1.13	3.00	0.25 x 0.125
4 x 3 x 6	11.0	5.13	23.8	8.25	10.0	10.0	5.50	6.94	3.50	9.00	9.00	0.69	1.75	0.44	1.50	0.63	0.88	2.13	12.40	1.13	3.00	0.25 x 0.125
1½ x 1 x 8	6.50	4.00	23.1	8.25	8.75	8.75	4.50	6.94	3.50	7.88	7.88	0.69	1.50	0.44	1.50	0.63	0.75	2.00	12.69	1.38	3.00	0.31 x 0.156
2 x 1½ x 8	6.50	4.00	23.2	8.25	8.75	8.75	4.50	6.94	3.50	7.88	7.88	0.69	1.50	0.44	1.50	0.63	0.75	2.00	12.75	1.38	3.00	0.31 x 0.156
3 x 1½ x 8	8.50	4.00	23.2	8.25	8.75	8.75	4.50	6.94	3.50	7.88	7.88	0.69	1.50	0.44	1.50	0.63	0.75	2.00	12.75	1.38	3.00	0.31 x 0.156
3 x 2 x 8	9.50	4.00	23.2	8.25	8.75	8.75	4.50	6.94	3.50	7.88	7.88	0.69	1.50	0.44	1.50	0.63	0.75	2.00	12.75	1.38	3.00	0.31 x 0.156
4 x 3 x 8	11.0	4.00	23.4	8.25	9.87	9.87	5.13	7.81	3.50	9.00	9.00	0.69	1.75	0.44	1.50	0.63	0.88	2.13	13.00	1.38	3.00	0.31 x 0.156
6 x 4 x 8	11.3	5.50	25.2	8.25	11.5	11.5	5.50	7.81	3.50	10.5	10.5	0.69	2.00	0.44	1.50	0.63	0.88	2.50	13.25	1.38	3.00	0.31 x 0.156
2 x 1½ x 10	9.06	4.13	23.5	8.25	9.00	9.00	4.50	6.94	3.50	8.38	8.38	0.69	1.50	0.44	0.75	0.63	0.75	1.88	12.88	1.38	3.00	0.31 x 0.156
3 x 1½ x 10	8.88	5.00	24.2	8.25	9.00	9.00	4.50	6.94	3.50	8.38	8.38	0.69	1.50	0.44	0.75	0.63	0.75	1.88	12.88	1.38	3.00	0.31 x 0.156
3 x 2 x 10	9.50	4.00	23.2	8.25	9.00	9.00	4.50	6.94	3.50	8.38	8.38	0.69	1.50	0.44	1.50	0.63	0.88	1.88	12.75	1.38	3.00	0.31 x 0.156
4 x 3 x 10	10.5	5.25	24.6	9.50	11.5	11.5	5.00	8.81	3.50	10.5	10.5	0.69	1.50	0.44	1.50	0.63	0.88	2.75	12.88	1.38	3.00	0.31 x 0.156
6 x 4 x 10	11.5	5.88	25.4	9.50	14.0	14.0	6.00	8.81	3.50	12.5	12.5	0.69	2.00	0.44	1.50	0.63	0.88	3.50	13.00	1.38	3.00	0.31 x 0.156
6 x 6 x 10	15.1	6.88	26.5	9.50	15.5	15.5	7.25	10.9	3.50	14.0	14.0	0.69	2.56	0.44	2.00	0.63	1.00	3.25	13.25	1.38	3.00	0.31 x 0.156
8 x 6 x 10	15.0	6.63	26.6	9.50	15.5	15.5	7.25	10.9	3.50	14.0	14.0	0.69	2.56	0.44	2.00	0.63	1.00	3.25	13.56	1.38	3.00	0.31 x 0.156
2 x 1½ x 13	10.0	5.00	28.5	11.0	10.0	10.0	5.00	7.81	4.75	9.00	9.00	1.25	1.50	0.56	0.75	0.63	0.75	2.13	17.00	2.00	3.00	0.50 x 0.250
3 x 2 x 13	11.0	5.10	28.6	11.0	11.5	11.5	5.00	8.81	4.75	10.3	10.3	1.25	1.50	0.56	1.50	0.63	0.88	2.63	17.00	2.00	3.00	0.50 x 0.250
4 x 3 x 13	12.5	5.50	29.1	11.0	12.5	12.5	5.00	9.69	4.75	11.0	11.0	1.25	1.50	0.56	1.50	0.63	0.88	3.25	17.16	2.00	3.00	0.50 x 0.250
6 x 4 x 13	12.8	6.00	29.8	11.0	15.0	15.0	7.25	9.69	4.75	13.8	13.8	1.25	2.50	0.56	1.50	0.63	0.88	3.25	17.36	2.00	3.00	0.50 x 0.250
6 x 6 x 13	16.1	7.52	31.4	11.0	15.5	15.5	7.25	12.4	4.75	14.3	14.3	1.25	2.50	0.56	2.00	0.63	1.00	3.00	17.40	2.00	3.00	0.50 x 0.250
8 x 6 x 13	16.3	6.75	31.0	11.0	15.5	15.5	7.25	12.4	4.75	14.3	14.3	1.25	2.50	0.56	2.00	0.63	1.00	3.00	17.80	2.00	3.00	0.50 x 0.250
10 x 8 x 13	18.5	8.50	32.9	11.0	17.5	17.5	8.00	13.9	4.75	16.0	16.0	1.25	2.75	0.56	2.00	0.63	1.13	3.50	17.96	2.00	3.00	0.50 x 0.250
12 x 10 x 13	22.5	10.5	35.5	11.0	22.5	22.5	10.0	15.9	4.75	21.0	21.0	1.25	3.50	0.56	2.00	0.63	1.13	3.50	18.50	2.00	3.00	0.50 x 0.250
8 x 6 x 16	17.8	7.00	31.3	11.0	16.75	16.7	16.8	12.4	4.75	15.5	15.5	1.25	2.00	0.56	1.25	0.63	0.88	2.50	17.78	2.00	3.00	0.50 x 0.250
10 x 8 x 16	20.3	7.50	31.9	11.0	21.0	21.0	10.0	13.9	4.75	19.5	19.5	1.25	3.50	0.56	2.00	0.63	1.06	4.00	17.92	2.00	3.00	0.50 x 0.250
14 x 12 x 16	26.0	12.0	52.0	11.0	21.0	26.9	11.0	19.9	4.75	19.0	24.9	1.50	4.00	0.63	2.75	0.75	1.38	4.00	27.95	3.00	5.75	0.75 x 0.375
8 x 6 x 20	19.8	7.25	31.2	11.0	22.0	22.0	10.0	14.9	4.75	19.5	19.5	1.50	3.50	0.56	2.00	0.63	1.06	4.00	17.13	2.00	3.00	0.50 x 0.250
10 x 8 x 20	22.0	7.88	32.0	11.0	23.0	23.0	10.0	16.6	4.75	21.5	21.5	1.50	3.50	0.56	2.00	0.63	1.06	4.00	17.38	2.00	3.00	0.50 x 0.250
12 x 10 x 20	26.4	7.88	47.8	12.0	20.0	24.0	10.4	18.6	5.00	17.9	21.9	1.00	3.38	0.63	2.16	0.75	1.38	4.00	28.30	3.00	5.75	0.75 x 0.375
14 x 12 x 20	29.6	12.0	52.5	12.0	22.6	29.6	13.8	21.9	5.00	20.3	27.3	1.00	4.50	0.63	2.84	0.75	1.63	5.13	28.96	3.00	5.75	0.75 x 0.375



1. All dimensions in inches, unless otherwise noted.
2. All tolerances +/- 0.125 inch.
3. Not valid for construction unless certified.

Dwg: SP-MAX-5, Rev: 0

**Standard Pump / Motor Assembly Dimensions
All 6", 8", and 10" Impeller Sizes**

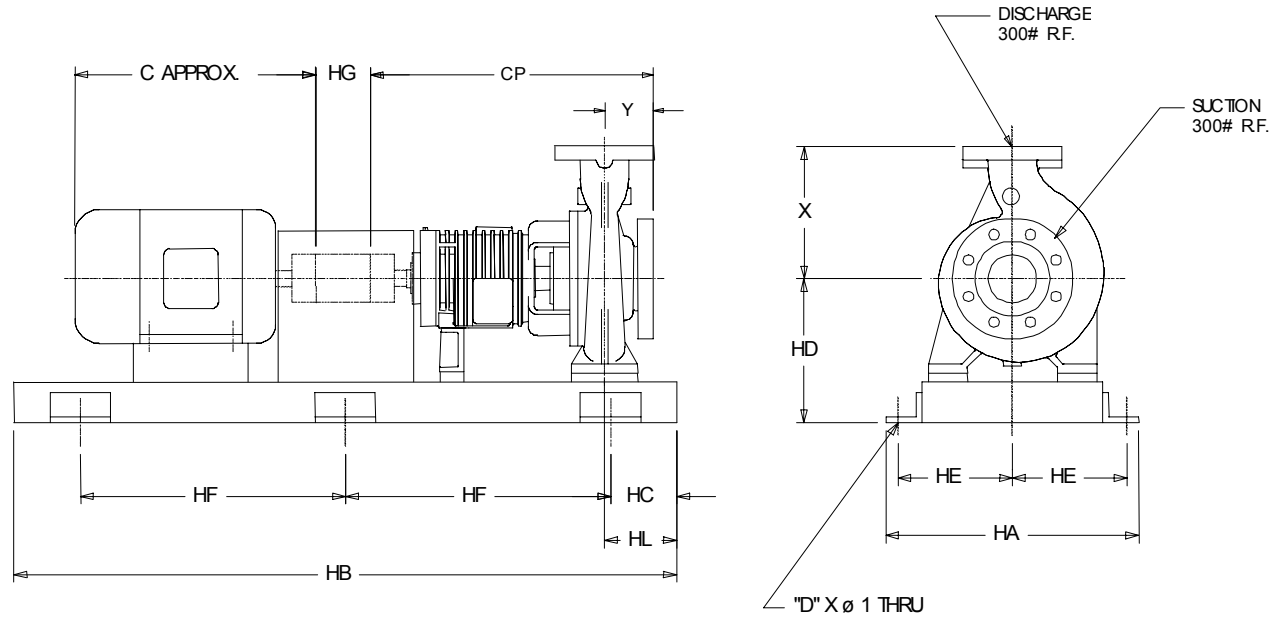

Pump Size	Pump Dimensions																		
	X	Y	CP	HG	HL	182 - 184 T		213 - 215 T		254 - 256 T		284 - 286 TS		324 - 326 TS		364 - 365 TS		404 - 405 TS	
						Base	HD	Base	HD	Base	HD	Base	HD	Base	HD	Base	HD	Base	HD
1½ x 1 x 6	6.50	4.00	22.4	5.00	6.00	1	10.0	-	-	-	-	-	-	-	-	-	-	-	-
2 x 1½ x 6	6.50	4.00	22.5	5.00	6.00	1	10.0	1	10.0	-	-	-	-	-	-	-	-	-	-
3 x 1½ x 6	6.50	4.00	22.5	5.00	6.00	1	10.0	1	10.0	-	-	-	-	-	-	-	-	-	-
3 x 2 x 6	8.25	4.00	22.5	5.00	6.00	1	10.0	1	10.0	2	10.5	2	11.0	-	-	-	-	-	-
4 x 3 x 6	11.0	5.13	23.8	5.00	7.00	1	11.0	1	11.0	2	11.0	2	11.0	4	13.0	-	-	-	-
1½ x 1 x 8	6.50	4.00	23.1	5.00	6.00	1	11.0	1	11.0	2	11.0	-	-	-	-	-	-	-	-
2 x 1½ x 8	6.50	4.00	23.2	5.00	6.00	1	11.0	1	11.0	2	11.0	2	11.0	-	-	-	-	-	-
3 x 1½ x 8	8.50	4.00	23.2	5.00	6.00	1	11.0	1	11.0	2	11.0	2	11.0	-	-	-	-	-	-
3 x 2 x 8	9.50	4.00	23.2	5.00	6.00	1	11.0	1	11.0	2	11.0	2	11.0	3	13.0	-	-	-	-
4 x 3 x 8	11.0	4.00	23.4	5.00	7.00	-	-	1	12.0	2	12.0	2	12.0	4	13.0	4	14.0	-	-
6 x 4 x 8	11.3	5.50	25.2	5.00	7.00	-	-	-	-	2	12.0	2	12.0	4	13.0	4	14.0	5	14.00
2 x 1½ x 10	9.06	4.13	23.5	5.00	6.00	1	11.0	1	11.0	2	11.0	2	11.0	3	12.5	-	-	-	-
3 x 1½ x 10	8.88	5.00	24.2	5.00	6.50	1	11.0	1	11.0	2	11.0	2	11.0	4	13.0	-	-	-	-
3 x 2 x 10	9.50	4.00	23.2	5.00	6.50	1	11.0	1	11.0	2	11.0	2	11.0	4	13.0	4	14.0	-	-
4 x 3 x 10	10.5	5.25	24.6	5.00	7.00	-	-	3	13.5	3	13.5	3	13.5	4	13.5	4	13.5	5	14.00
6 x 4 x 10	11.5	5.88	25.4	5.00	7.00	-	-	-	-	3	13.5	3	13.5	4	13.5	5	14.0	5	15.00
6 x 6 x 10	15.1	6.88	26.5	7.25	8.00	-	-	-	-	5	16.0	5	16.0	5	16.0	-	-	-	-
8 x 6 x 10	15.0	6.63	26.6	7.25	7.00	-	-	-	-	-	-	5	16.0	5	16.0	5	16.0	-	-

Baseplate Number	Baseplate Dimensions					
	HA	HB	HC	HE	HF	D
1	21.0	55.0	5.50	9.50	22.0	6.00
2	21.0	61.0	5.50	9.50	25.0	6.00
3	24.0	61.00	5.50	11.0	25.0	6.00
4	24.0	73.0	6.50	11.0	30.0	6.00
5	30.0	73.0	6.50	14.0	30.0	6.00

NEMA Motor Dimensions (Approximate)					
NEMA Frame	C	NEMA Frame	C	NEMA Frame	C
182T	15	256T	25	364TS	31
184T	16	284TS	25	365TS	32
213T	18	286TS	27	404TS	38
215T	19	324TS	28	405TS	40
254T	23	326TS	29		



1. All dimensions in inches, all tolerances +/- 0.125 inch.
2. All motor dimensions are approximate.
3. Not valid for construction unless certified.

Dwg: SP-MAX-6, Rev: 0

**Standard Pump / Motor Assembly Dimensions
All 13", 16", and 20" Impeller Sizes**

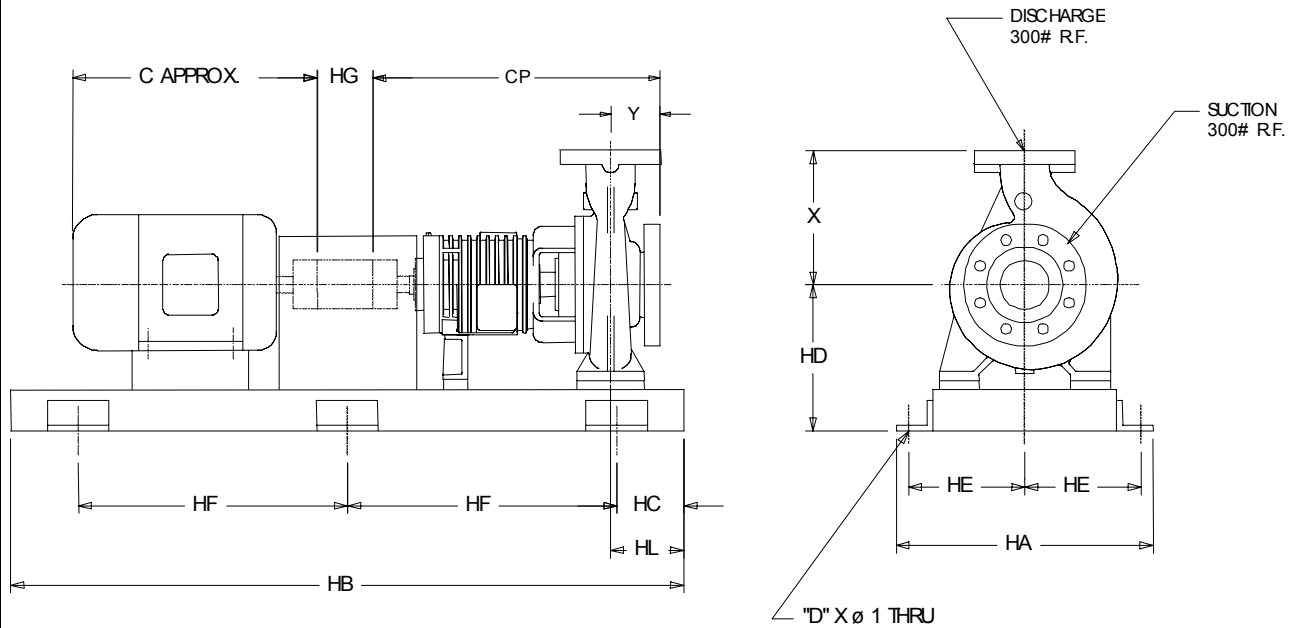

Pump Size	Pump Dimensions																		
	X	Y	CP	HG	HL	254 - 256 T		284 - 286 TS		324 - 326 TS		364 - 365 TS		404 - 405 TS		444 - 445 TS		447 TS	
						Base	HD	Base	HD	Base	HD	Base	HD	Base	HD	Base	HD	Base	HD
2 x 1½ x 13	10.0	5.00	28.5	5.00	6.50	2	12.0	4	12.5	4	12.5	4	13.5	-	-	-	-	-	-
3 x 2 x 13	11.0	5.10	28.6	5.00	6.50	2	13.0	4	13.5	4	13.5	4	14.0	5	14.00	6	15.00	-	-
4 x 3 x 13	12.5	5.50	29.1	5.00	7.00	3	14.5	4	14.5	4	14.5	4	14.5	6	14.00	6	15.00	-	-
6 x 4 x 13	12.8	6.00	29.8	5.00	7.50	-	-	4	14.5	4	14.5	4	14.5	6	14.00	6	15.00	6	15.0
6 x 6 x 13	16.1	7.52	31.4	7.25	9.00	-	-	-	-	5	16.5	5	16.5	6	16.50	-	-	-	-
8 x 6 x 13	16.3	6.75	31.0	7.25	8.00	-	-	-	-	5	16.5	5	16.5	6	16.50	-	-	-	-
10 x 8 x 13	18.5	8.50	32.9	7.25	10.0	-	-	-	-	-	-	5	18.0	6	18.00	6	18.00	-	-
12 x 10 x 13	22.5	10.5	35.5	8.00	13.0	-	-	-	-	-	-	28	25.3	29	25.25	30	25.25	-	-
8 x 6 x 16	17.8	7.00	31.3	7.25	8.50	-	-	-	-	-	-	6	16.5	6	16.50	6	16.50	-	-
10 x 8 x 16	20.3	7.50	31.9	7.25	8.50	-	-	-	-	-	-	-	6	18.00	6	18.00	6	18.0	
14 x 12 x 16	26.0	12.0	52.0	9.75	13.0	-	-	-	-	-	-	-	-	-	36	29.25	36	29.3	
8 x 6 x 20	19.8	7.25	31.2	7.25	8.50	-	-	-	-	-	-	-	6	19.0	6	19.0	6	19.0	
10 x 8 x 20	22.0	7.88	32.0	7.25	9.00	-	-	-	-	-	-	-	28	25.3	28	25.3	28	25.3	
12 x 10 x 20	26.4	7.88	47.8	7.25	9.00	-	-	-	-	-	-	-	30	27.8	30	27.8	30	27.8	
14 x 12 x 20	29.6	12.0	52.5	9.75	13.0	-	-	-	-	-	-	-	-	-	47	33.8	47	33.8	

Baseplate Number	Baseplate Dimensions					
	HA	HB	HC	HE	HF	D
2	21.0	61.0	5.50	9.50	25.0	6.00
3	24.0	61.0	5.50	11.0	25.0	6.00
4	24.0	73.0	6.50	11.0	30.0	6.00
5	30.0	73.0	6.50	14.0	30.0	6.00
6	30.0	85.0	6.50	14.0	36.0	6.00
28	36.0	84.5	6.00	16.5	24.1	8.00
29	36.0	90.5	6.00	16.5	26.1	8.00
30	36.0	96.5	6.00	16.5	28.1	8.00
36	42.0	96.5	6.00	19.5	28.1	8.00
47	48.0	108.5	6.00	22.5	24.1	10.0

NEMA Motor Dimensions (Approximate)					
NEMA Frame	C	NEMA Frame	C	NEMA Frame	C
254T	23	326TS	29	444TS	42
256T	25	364TS	31	445TS	44
284TS	25	365TS	32	447TS	46
286TS	27	404TS	38		
324TS	28	405TS	40		



1. All dimensions in inches, all tolerances +/- 0.125 inch.
2. All motor dimensions are approximate.
3. Not valid for construction unless certified.

Dwg: SP-MAX-7, Rev: 0



Since we built our first pumps in 1938, the Carver name has become synonymous with value. Today we are recognized as one of the world's leading centrifugal pump companies, building pumps to the most demanding engineering specifications and military standards in the world.

Our company is located in Muscatine, Iowa, 25 miles southwest of the Quad Cities area. Our operations there include some of the most modern manufacturing equipment and pump development software available, and we are committed to the highest quality possible in our products and our people. Along these lines, Carver was also one of the first American pump companies to attain ISO 9001 certification—the most recognized standard for quality in the world.

From an applications standpoint Carver has traditionally built pumps for water, oil, and chemicals for both the public and private sectors. Our product line includes both horizontal and vertical end suction, multi-stage, axial split case, self-priming, API, and solids-handling pumps that all carry the same Carver trademark: lasting value from solid, straightforward designs engineered to provide many years of service.

These pumps are also backed by unparalleled aftermarket support. Our network of stocking distributors, manufacturer's representatives and certified service centers throughout the world means that no matter where your pump may be installed, there are local sales and service people ready to support your aftermarket needs.



Carver Pump Company

2415 Park Avenue • Muscatine, IA 52761

563.263.3410 • Fax: 563.262.0510

www.carverpump.com