

# **RS Series**

*Technical Support  
Information*

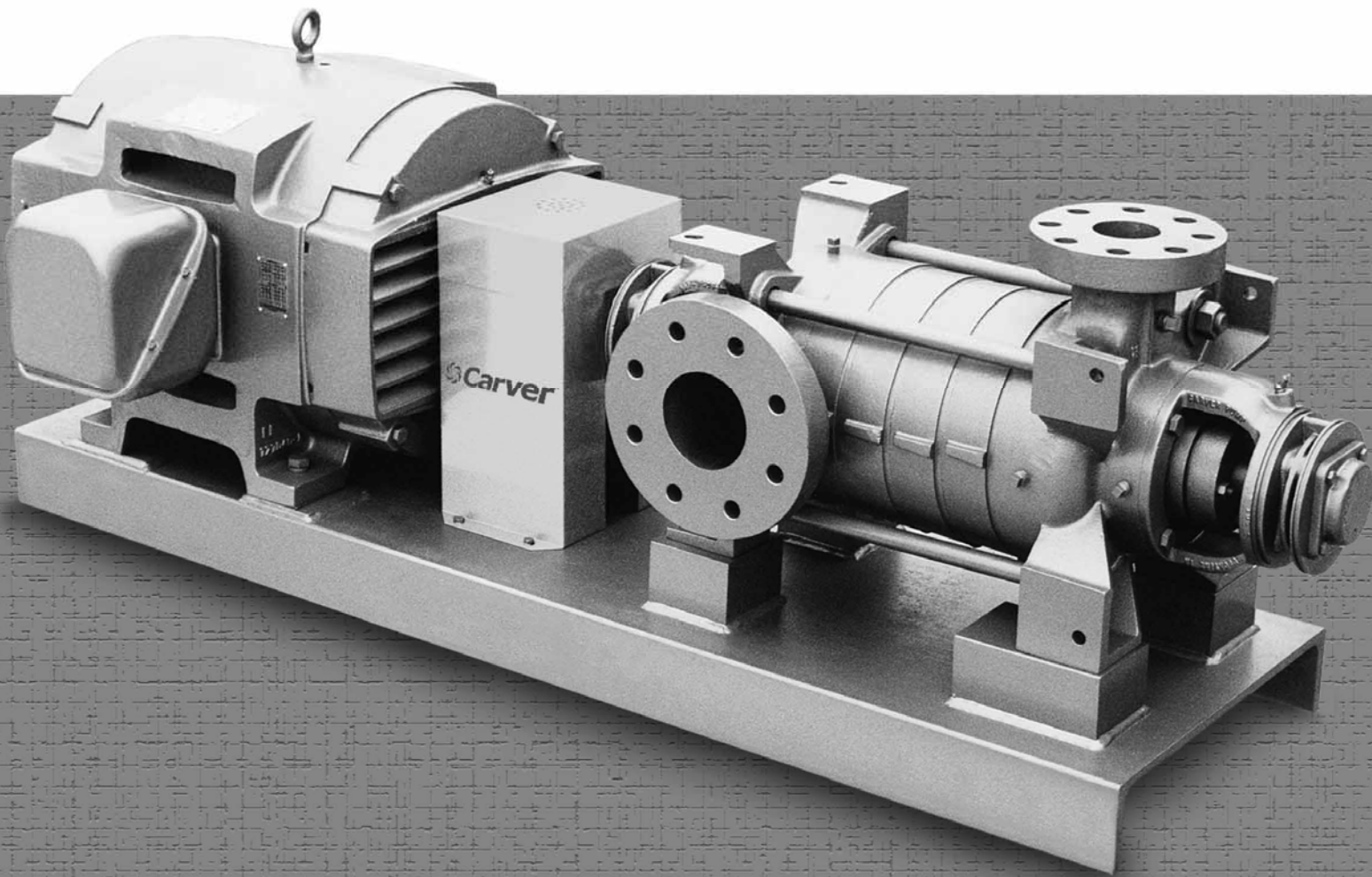

 **Carver<sup>®</sup>**

***Creating Value.***

MARCH  
2006

**1.0 Overview**

The RS Series is Carver’s multi-stage pump for fluids at moderate to high pressures. The standard RS pump is available in ductile iron or CD4MCu as either the **RS6** or **RS9**, depending on inlet and discharge pressures (the “6” or “9” refers to its ANSI 600 lb. or 900 lb discharge flange) in five basic sizes. There are four casing sizes, with the first two impeller sizes fitting in the same casing.

**1.1 Ordering Code**

When ordering an RS pump **this Ordering Code must be used**. Doing so enables us to accept orders quicker and to assure the timely and correct manufacture of the desired pump.

**RS 6 - BCG - AAA - APB**

**RS Multistage Ring Section Pump Series**

- 6 - 600 lb. discharge flange (assigned at time of order)
- 9 - 900 lb. discharge flange (assigned at time of order)

**Casing Nozzle and Impeller Sizes**

- A - 3 x 2 x 6 Low Flow
- B - 3 x 2 x 6 High Flow
- C - 4 x 2.5 x 7
- D - 6 x 3 x 8
- E - 6 x 4 x 10

**Basic Materials of Construction**

- A - Ductile iron casing with cast iron impellers
- B - Ductile iron casing with CD4 impellers
- C - CD4 casing and impellers
- X - Special

**Number of Stages**

- |              |               |               |
|--------------|---------------|---------------|
| A - 2 stages | G - 8 stages  | P - 14 stages |
| B - 3 stages | H - 9 stages  | Q - 15 stages |
| C - 4 stages | J - 10 stages | R - 16 stages |
| D - 5 stages | K - 11 stages | S - 17 stages |
| E - 6 stages | M - 12 stages | T - 18 stages |
| F - 7 stages | N - 13 stages |               |

**Bearing Lubrication Arrangement**

- A - Grease lubricated (standard)
- B - Oil lubricated
- C - Oil lubricated with jacketed casing for external cooling
- X - Special

**Inboard (Suction) End Sealing Arrangement**

- A - Type 1 seal w/ carbon on ni-resist, Viton and 316 SS parts (standard)
- B - Type 1 seal w/ carbon on Si C, EPDM and 316 SS parts
- X - Special seal and/or flush plan

**Outboard (Discharge) End Sealing Arrangement**

- A - No seal, antimony impregnated carbon sleeve bearing (standard)
- B - Type 8B -1 seal w/ carbon on Si C, EPDM and 316 SS components
- C - Type 8B -1 seal as above w/ Plan 21 flush and external heat exchanger
- X - Special seal and/or flush plan

**NEMA Motor @ 230/460 Volt, 60 Hz**

- A - 1750 RPM, ODP, standard efficiency
- B - 3500 RPM, ODP, standard efficiency
- C - 1750 RPM, ODP, premium efficiency
- D - 3500 RPM, ODP, premium efficiency
- E - 1750 RPM, TEFC, standard efficiency
- F - 3500 RPM, TEFC, standard efficiency
- G - 1750 RPM, TEFC, premium efficiency
- H - 3500 RPM, TEFC, premium efficiency
- J - 1750 RPM, Explosion proof, standard efficiency
- K - 3500 RPM, Explosion proof, standard efficiency

- X - Special
- Z - None

**Motor Size (for assemblies with base, etc.)**

- |            |                                     |
|------------|-------------------------------------|
| K - 25 HP  | T - 150 HP                          |
| L - 30 HP  | U - 200 HP                          |
| M - 40 HP  | V - 250 HP                          |
| N - 50 HP  | Y - 300 HP                          |
| P - 60 HP  |                                     |
| Q - 75 HP  | X - Special or above 300 HP         |
| R - 100 HP |                                     |
| S - 125 HP | Z - None or customer supplied motor |

**Base and Coupling**

- A - Standard base with standard coupling and guard
- B - Standard base with spacer-type coupling and guard

- X - Special
- Z - No base, coupling guard or motor - bare pump only

**1.2 Key Dimensions**

All RS suction flanges are ANSI Class 300 rated. The discharge flanges are either ANSI Class 600 or 900 rated, depending on the number of stages and pressures involved.

<b>Key RS Dimensions (inches)</b>				
Size	A, B	C	D	E
Inlet flange size	3"	4"	6"	6"
Discharge flange size	2"	2 1/2 "	3"	4"
Shaft diameter at impeller	1.437	1.437	1.574	1.771
Shaft diameter at coupling	1.250	1.250	1.500	1.625
Seal diameter - suction	1.750	1.750	2.125	2.375
Seal diameter - discharge	1.875	1.875	2.375	2.375
Front wear ring clearance - min	0.015	0.013	0.012	0.011
Front wear ring clearance - max	0.019	0.017	0.018	0.016
Rear wear ring clearance - min	0.015	0.013	0.017	0.011
Rear wear ring clearance - max	0.019	0.017	0.021	0.016

Replaceable wear rings are provided at each stage of the RS. One ring is at each impeller eye, held in place by the suction casing (first stage only) or interstage casing. The second ring is behind the impeller, held in place by the diffuser.

Wear rings are Rulon® for both cast iron and CD4MCu impellers.

<b>Key RS Mechanical Data</b>				
Size	A, B	C	D	E
Maximum speed	3500 RPM			
Max HP - (17-4 PH shaft)	370	370	603	900
Max HP - (416 SS shaft)	308	308	500	690
WR <sup>2</sup> of rotor - 1 <sup>st</sup> stage (lb-in <sup>2</sup> )	14.6	30.8	36.7	106.5
WR <sup>2</sup> of rotor - each stage (lb-in <sup>2</sup> )	10.2	26.7	31.1	94.4
Radial bearing type	307	307	308	309
Thrust bearing type	7307	7307	7308	7309

There is no minimum speed for RS pumps, but performance falls off with speed in accordance with the centrifugal pump affinity laws, and at some point it becomes more economical to use a smaller pump running faster. Maximum speeds, on the other hand, are well defined and must not be exceeded.

**1.3 Bearing and Seal Arrangements**

The standard RS design uses a pair of matched angular contact ball bearings for axial thrust loads and a product lubricated, antimony impregnated carbon sleeve bearing for the radial loads. For units with an optional outboard mechanical seal, a ball bearing is placed at the inboard end with the thrust bearings moved to the outboard end, behind the seal.

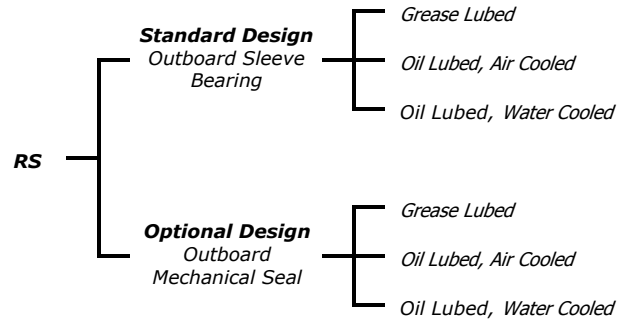

The standard ball bearings are grease lubricated and regreasable, with optional oil lubricated bearings for more effective lubricant penetration of the bearing internals. The oil lubricated bearings also carry the additional option of a jacketed bearing frame for external water cooling.

<b>Bearing Temperature Limits</b>			
Bearing	Cooling	Min	Max
Grease Lube	Air	-20° F	180° F
Oil Lube	Air	-20° F	225° F
	1 GPM water flush	225° F	285° F
	2 GPM water flush	285° F	410° F

<b>Seal Temperature Limits</b>			
Seal	Cooling	Min	Max
XF <sub>51</sub> 171	Air	-20° F	225° F
O <sub>28</sub> F <sub>147</sub> 10 <sub>58</sub> 1	Air	-20° F	285° F
	2 GPM water flush @ 60° F	285° F	410° F

These bearing and seal temperatures limits must be observed to avoid adversely effecting pump life, permanently degrading the fluid, bringing the pump out of alignment, and/or seizing the pump.

The RS warranty is also based on strict adherence to these limits.

**1.4 Pressure Limits**

The **minimum** net positive suction head (NPSH) required is the net amount of hydraulic energy above vapor pressure needed to overcome elevation and friction losses and deliver fluid into the eye of the impeller. If insufficient NPSH is present, cavitation occurs.

Cavitation is a serious problem, and some of its consequences are:

- a vacuum can occur in the stuffing box, drawing in air through the seal faces and causing an erratic loss of flow and/or prime
- the pump will be noisy, and the ensuing vibration will make it difficult to maintain pump/motor alignment
- there will be accelerated wear of the pump internals

The **maximum** suction pressure, on the other hand, is based on the shaft seal, balance line configuration and the structures limits of the pump. Too high an inlet pressure can cause the mechanical seal to leak, and/or create unbalanced forces on the impellers and bearings that will increase their wear rates.

Max Allowed Pressures		
Size	Inlet	Discharge
A	415 PSIG	1,475 PSIG
B		1,475 PSIG
C		1,475 PSIG
D		1,810 PSIG
E		1,460 PSIG

The maximum allowable working pressure (MAWP) for sizes A, B, and C is determined by the strength of the bolting that attaches the outboard (discharge) end gland or sleeve bearing cap. The MAWP for sizes D and E is determined by the strength of the threaded connections of the tie rods to the suction casing.

In all cases the maximum suction and discharge pressures must be independently observed, and a pump must **never be allowed to operate under a condition where either one of these guidelines by itself is exceeded, even if the other guideline is not.**

**1.5 Materials of Construction**

The standard RS materials and material specifications are given in the table below:

Key Component Materials			
Component	Material	Specification	
Casings	Ductile iron	ASTM A-536-70	
	CD4MCu	ASTM 890	
Impellers and Diffuser	Cast iron	ASTM A-48 Cl.30	
	CD4MCu	ASTM 890	
Shafts	416 SS	ASTM A-582	
	17-4 PH SS	ASTM A-564	
Shaft sleeves	Stainless Steel		
Tie rods	Steel	ASTM A-193	
	17-4 PH SS	ASTM A-564	
Sleeve bearing	Composite with Moly/PTFE additives		
Casing O rings	Viton		
Wear rings	Rulon®		
<b>Seal - Standard</b>	Type 1	XF <sub>51</sub> 171(316)	
Elastomers	Viton®		
Rotating face	Carbon		
Metal parts	316 SS		ASTM A-276
Stationary face	Ni-resist		
<b>Seal - Optional</b>	Type 1	O <sub>28</sub> P <sub>147</sub> 1O <sub>58</sub> 1(316)	
Elastomers	EPDM		
Rotating face	Antimony / carbon		
Metal parts	316 SS		ASTM A-276
Stationary face	Silicon carbide		

**1.6 Key Hydraulic Data**

The key hydraulic data for the standard pump with enclosed impellers is shown below.

Key RS Hydraulic Data					
Item	Pump Size				
	A	B	C	D	E
Max diameter (D <sub>2</sub> )	6.50"	6.50"	7.56"	8.68"	10.44"
Min diameter (D <sub>2</sub> )	5.25"	5.25"	6.50"	7.00"	8.00"
Max no. stages	18	18	12	12	8
Min flow (GPM)	35	50	100	200	200
Specific speed N <sub>s</sub>	988	1,233	1,272	1,216	1,608

Note that the max. stages listed are for pumps operating at 1750 RPM. Higher speeds may result in fewer stages allowed. Refer to Note 3 at the bottom of each Performance Curve, pgs. 6 – 10, for stage limitations at higher speeds.

## 2.0 A Typical Specification

Each pump shall be a horizontal ring section multi-stage pump capable of developing up to 2,800 ft of head without the use of special clearances, materials, or other internal or external modifications. The conditions of service for the pump shall be (500) US GPM at a total head of (2,000) feet when pumping (water) at a temperature of (100°) F with a fluid specific gravity of (1.00). In meeting these hydraulic conditions the pump shall have an NPSH requirement of not more than (10) feet and a hydraulic operating efficiency at the normal duty point of at least (60.0)% as defined by the Hydraulic Institute Level A requirements, which includes all mechanical seal losses.

The pump shall include individual suction, discharge and interstage casings. The suction connection shall be a raised face ANSI 300 lb flange and the discharge connection shall be a raised face ANSI 600 (900) lb. flange. The interstage casings shall be radially split and machined with 360° rabbet fits for minimal shaft deflection and easy removal and reassembly of the unit. The suction and discharge housings shall be integral with the pump feet and rotatable in 90° increments to accommodate varying field piping orientations. The entire assembly shall be secured with a minimum of four steel (17-4 PH stainless steel) tie rods and Viton O rings to assure complete hydraulic and structural integrity of the unit.

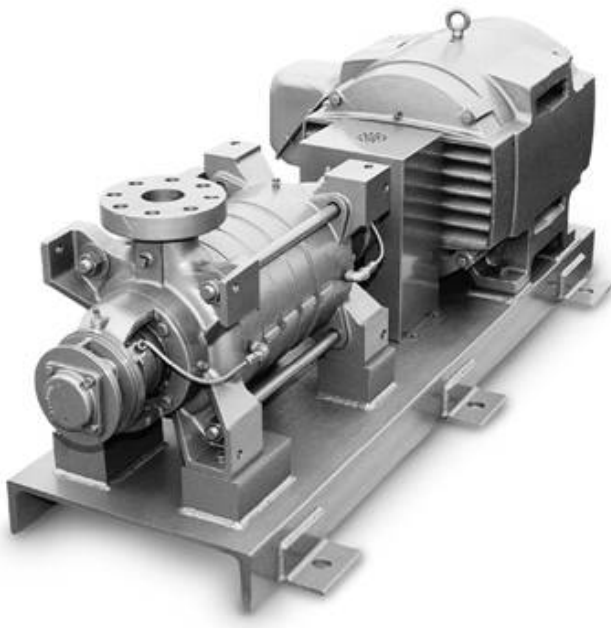

The impellers shall be enclosed type and positively keyed to the pump drive shaft. They shall be precision cast iron (CD4MCu duplex stainless steel) with all trimming limited to the impeller vanes only (no shroud trimming) for higher efficiencies. As a further means of assuring longer component life, all impellers shall be dynamically balanced in accordance with ISO G2.5 guidelines.

The pump shall have replaceable Rulon® front and rear wear rings at each pump stage. The front wear ring shall be at the impeller eye, held in place by the suction casing (first stage only) or interstage casing. The rear wear ring shall be behind the impeller, held in place by the diffuser. The diffusers shall be cast iron (CD4MCu duplex stainless steel) with unobstructed passageways for minimal interstage losses. They shall be separate from the interstage casing to allow for individual replacement without also requiring replacement of the interstage casing.

The pump shall have one inboard (suction) end mechanical seal and be capable of accepting either component or cartridge type mechanical seals. The seals shall have EPDM elastomers, 316 stainless steel metal components and carbon on ni-resist (silicon carbide) faces that are capable of operating up to 230° F without external cooling. When an outboard (discharge) end mechanical seal is provided, the pump shall be equipped with a 316 stainless steel balance line to facilitate flushing and equalize the pressure in the discharge stuffing box to that of the suction stuffing box.

The drive shaft shall be 416 stainless steel (17-4 PH stainless steel) with the impellers indexed on the shaft in 90° offsets for balancing and uniform stress relief during thermal shocking situations. The shaft shall be provided with replaceable 17-4 PH stainless steel interstage sleeves for protection from erosion and corrosion.

The thrust bearing shall consist of a pair of matched angular contact ball bearings to handle axial thrust in either direction. The radial bearing shall be a product lubricated, composite with Moly/PTFE additives sleeve type. For units with an outboard mechanical seal in place of the sleeve bearing, a deep grooved radial ball bearing shall be on the inboard end with the matched angular contact ball bearings moved to the outboard end. With either arrangement the ball bearings shall have the option of either oil or grease lubrication.

The pump shall be an RS Series heavy duty, process design pump 100% sourced and manufactured in the United States by the Carver Pump Company of Muscatine, Iowa, or approved US manufactured equal.

### 3.0 Conditions of Service Checklist

To successfully select an RS pump the following information must be known:

#### a. **Hydraulics**

- fluid to be pumped
- flow rate
- inlet pressure
- discharge pressure
- viscosity (min, normal and max)
- temperature (min, normal and max)
- specific gravity (min, normal and max)
- NPSH available
- vapor pressure
- preferred speed

#### b. **Materials**

- casing, stuffing box and end covers
- shafts
- impellers and diffusers
- seals
- wear rings

#### c. **Configurations / Accessories**

- driver (speed, type, rating, manufacturer)
- coupling (torque, type, manufacturer)
- bases (type, options)

### 3.1 Quick Selection Chart

With the above information, the pump selection can start by first referring to the Quick Selection Chart below for 60 hertz operation.

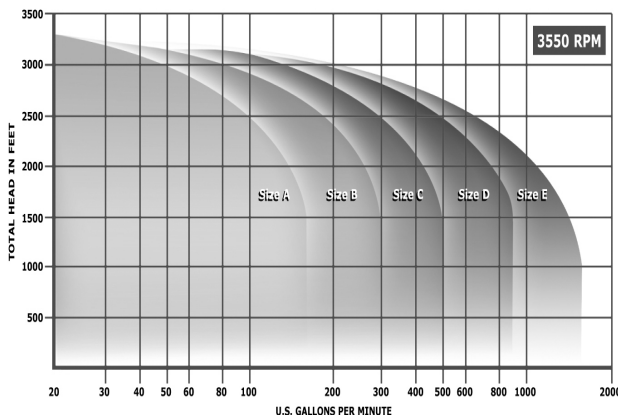

The selection can then be fine tuned by using the performance curves on the following pages to complete the process.

### 3.2 Using the Performance Curves

The performance curves for each size pump are at the 60 hertz synchronous motor speeds of 1750 and 3500 RPM. Each curve shows the power required, NPSH required, efficiencies and impeller diameters for their respective head and flow range with 60 °F water as the assumed fluid.

To select a pump find the curve for the pump size that meets the desired flow rate and speed. Next determine the number of stages needed to achieve the desired head

Since a multistage pump is analogous to a group of pumps operating in series (each stage acting as a separate pump), the flow rate remains unchanged with the number of stages, but the head developed increases with each stage. To determine the number of stages needed, divide the total head needed by the head developed per stage and round off to the next highest number. For instance, if 1,300 feet of head is needed and the pump in question develops 200 feet per stage, then seven (7) stages are required.

Once the number of stages is determined, the impeller trim (if necessary) is determined for the exact amount of head needed. In the above example, at 200 feet per stage a total of 1,400 feet would be developed, which is 100 feet more than is needed. Therefore, the last stage would be trimmed for only 100 feet of head. Then, with six untrimmed stages developing 200 feet per stage and the last stage developing 100 feet, the total desired head of 1,300 feet will be achieved.

Once head, flow, number of stages and impeller diameters are determined, the efficiency, power, and NPSH required can be determined. The efficiency is read directly off of the curves, and is the weighted average of the efficiency points for all the trimmed and untrimmed stages.

The power required is found in a similar fashion by adding all the individual power requirements per stage for the untrimmed and trimmed impellers. The NPSH required is then read off the same curves, with those values given on the right hand Y axis.

As a final step, any corrections for viscosities or specific gravities other than that of water can be made using the Hydraulic Institute charts and procedures. For conditions beyond the limits of the drawn curves, do not extrapolate – contact the Carver Sales and Marketing department.

**Hydraulic Performance – Size A: 3 x 2 x 6 (Low Flow)**

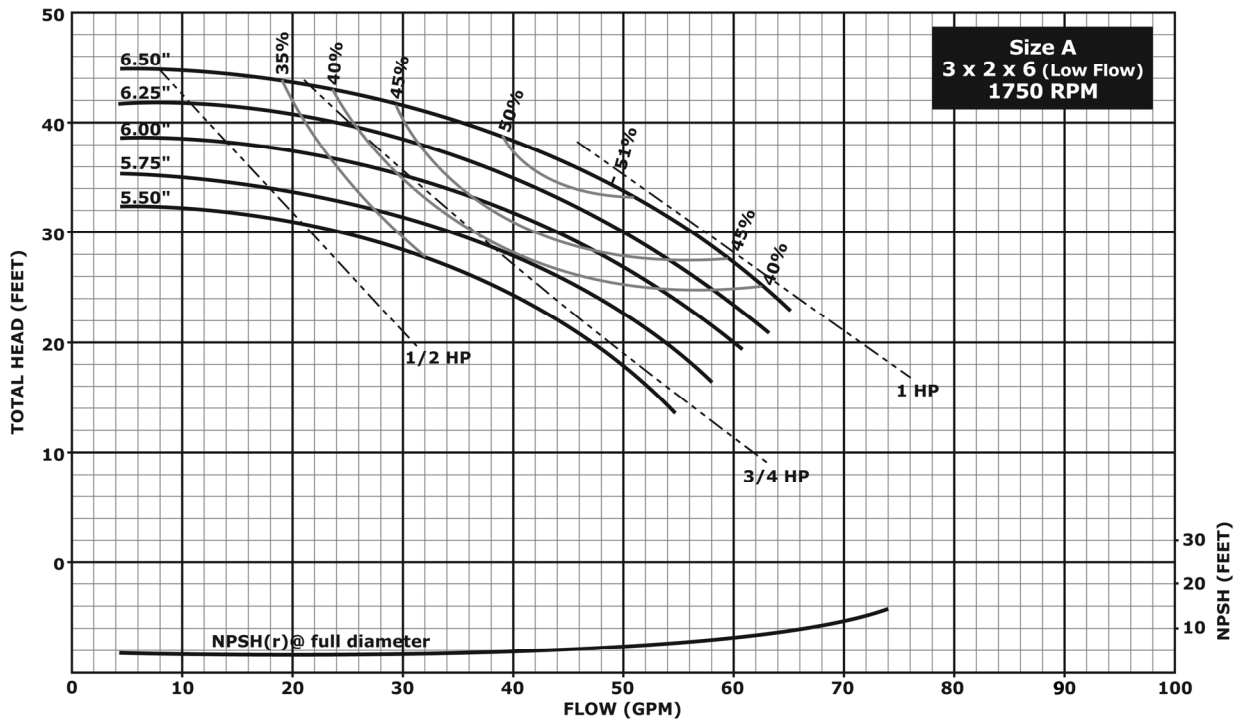
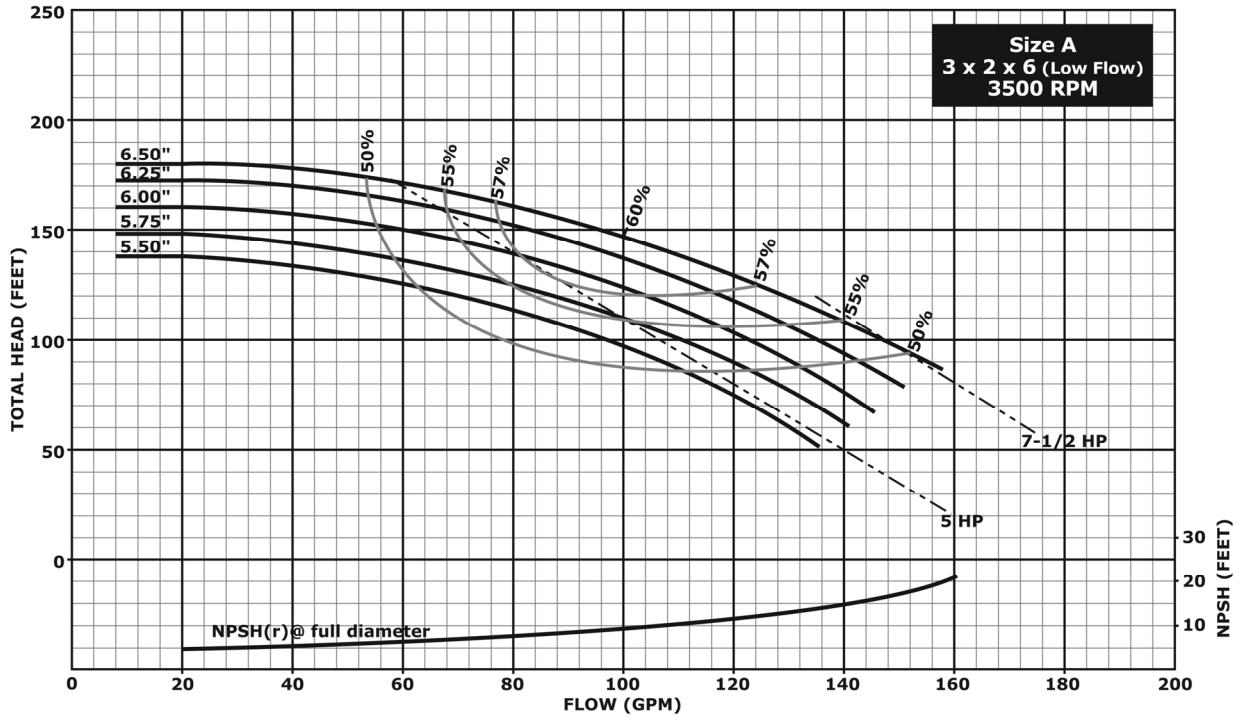

**Notes:**

1. Above curves show efficiency, flow and NPSHR performance on water at ambient temperature and atmospheric pressure.
2. For multi-stage performance, multiply head and power by the number of stages.
3. Size A available up to 18 stages at 1,750 RPM operating speed and up to 15 stages at 3,500 RPM operating speed.

Hydraulic Performance – Size B: 3 x 2 x 6 (High Flow)

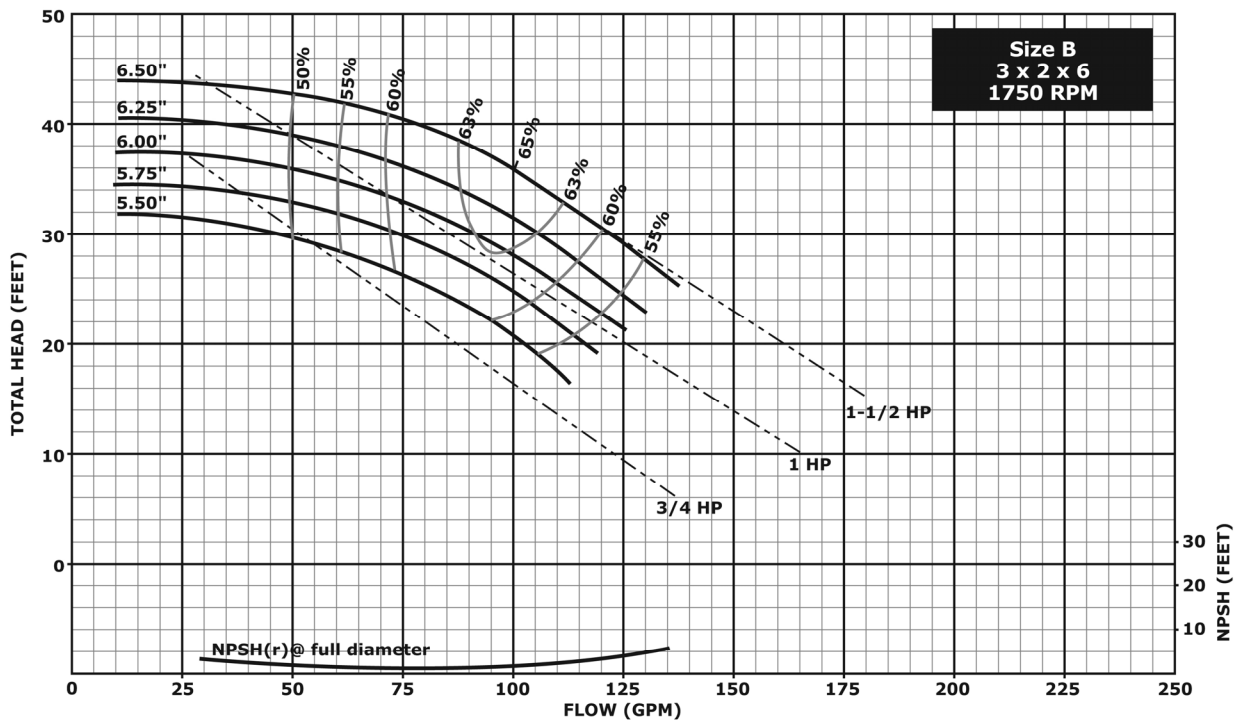
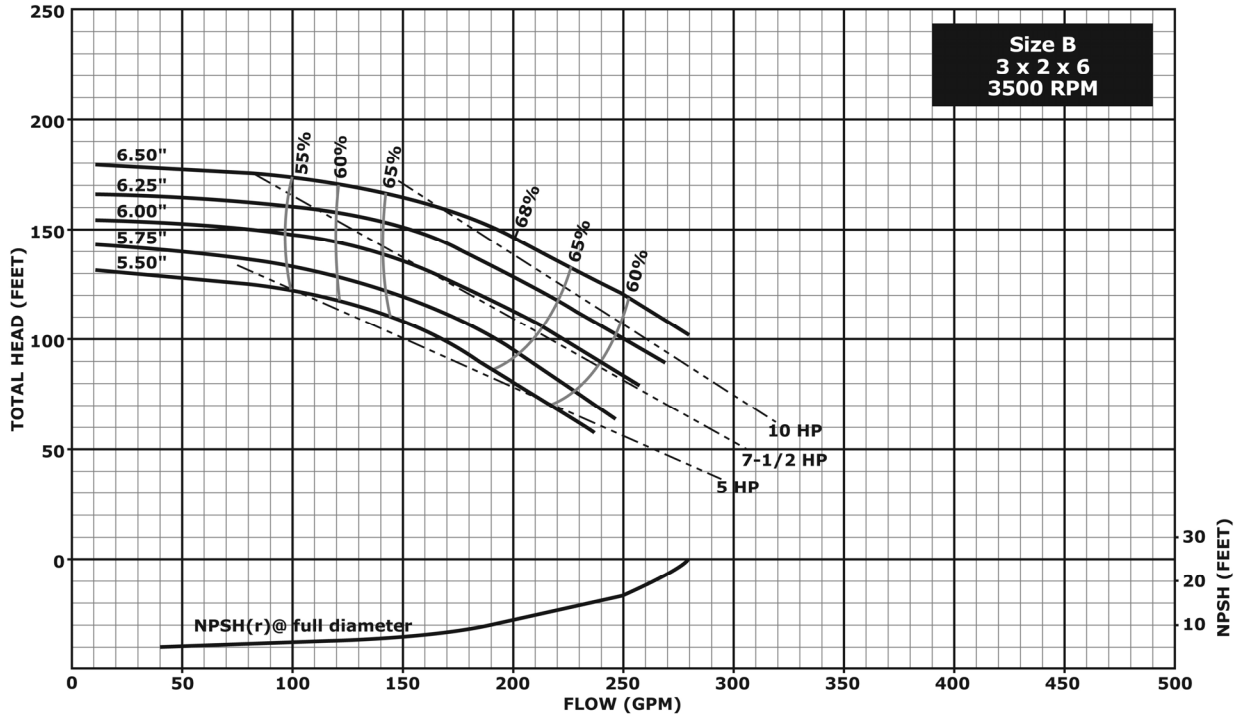

**Notes:**

1. Above curves show efficiency, flow and NPSHR performance on water at ambient temperature and atmospheric pressure.
2. For multi-stage performance, multiply head and power by the number of stages.
3. Size B available up to 18 stages at 1,750 RPM operating speed and up to 15 stages at 3,500 RPM operating speed.



Hydraulic Performance – Size C: 4 x 2 1/2 x 6

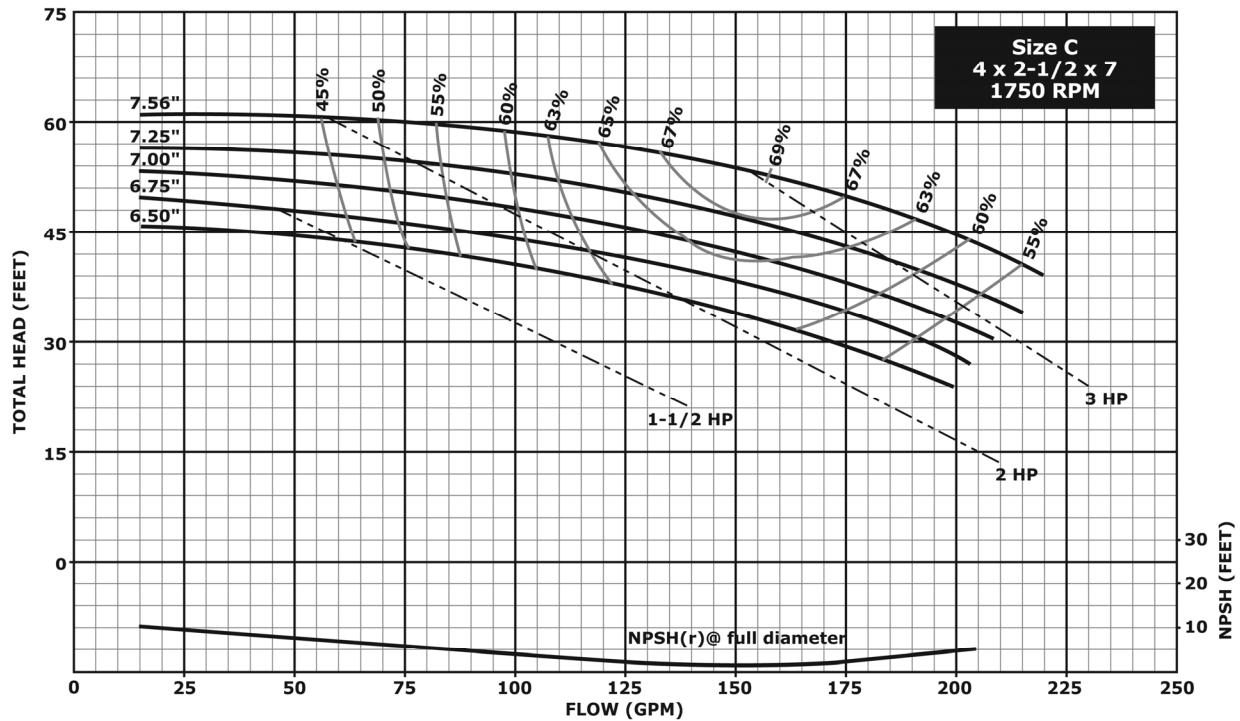
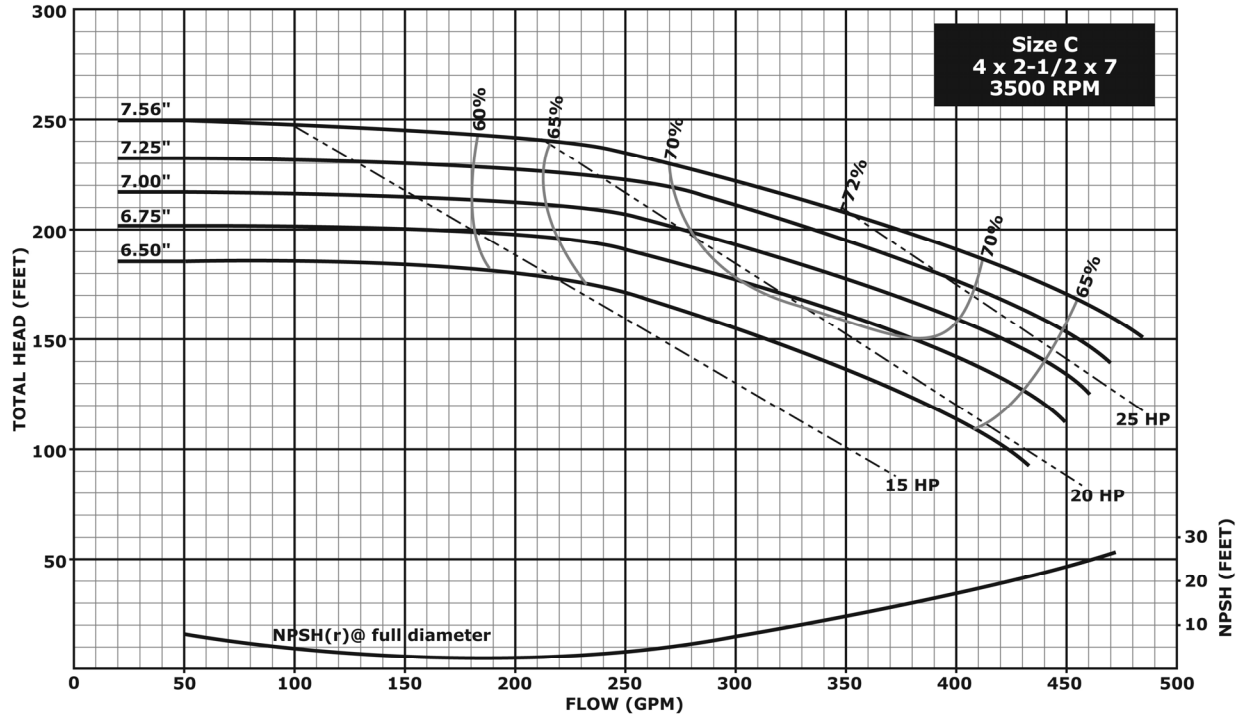

**Notes:**

1. Above curves show efficiency, flow and NPSHR performance on water at ambient temperature and atmospheric pressure.
2. For multi-stage performance, multiply head and power by the number of stages.
3. Size C available up to 12 stages for both 1,750 RPM and 3,500 RPM operating speeds.

Hydraulic Performance – Size D: 6 x 3 x 8

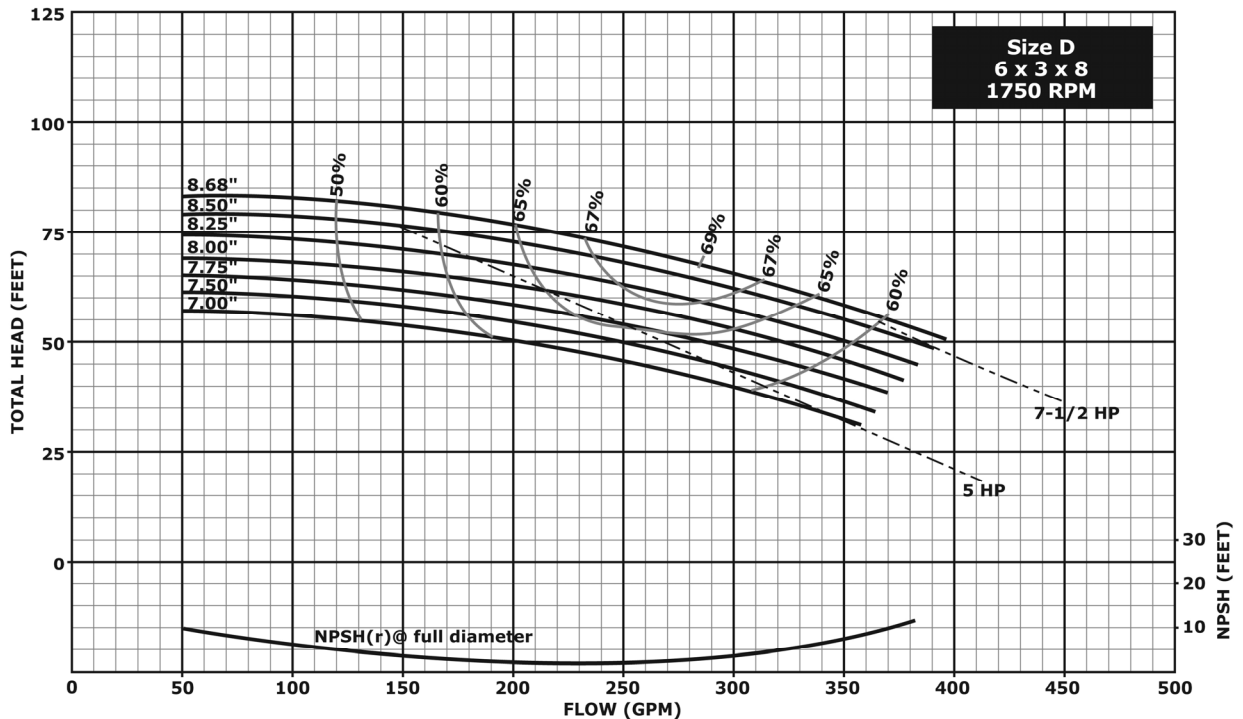
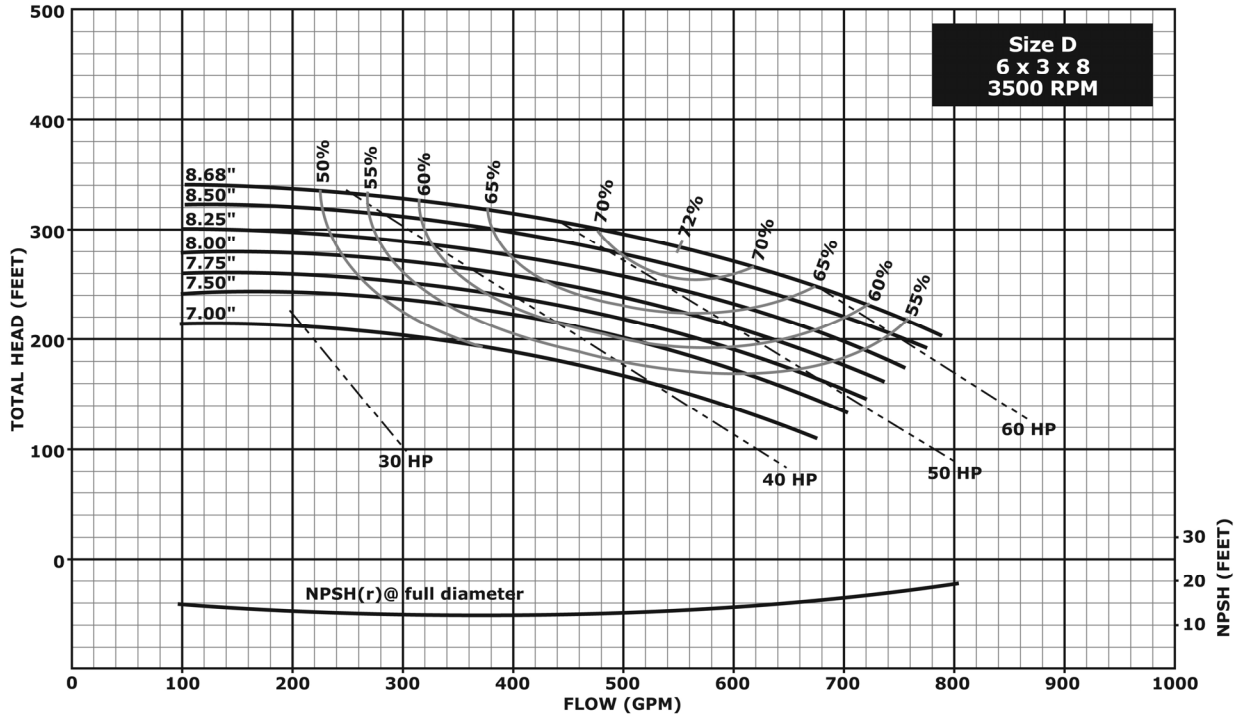

**Notes:**

1. Above curves show efficiency, flow and NPSHR performance on water at ambient temperature and atmospheric pressure.
2. For multi-stage performance, multiply head and power by the number of stages.
3. Size D available up to 10 stages at 1,750 RPM operating speed and up to 8 stages at 3,500 RPM operating speed.

Hydraulic Performance – Size E: 6 x 4 x 10

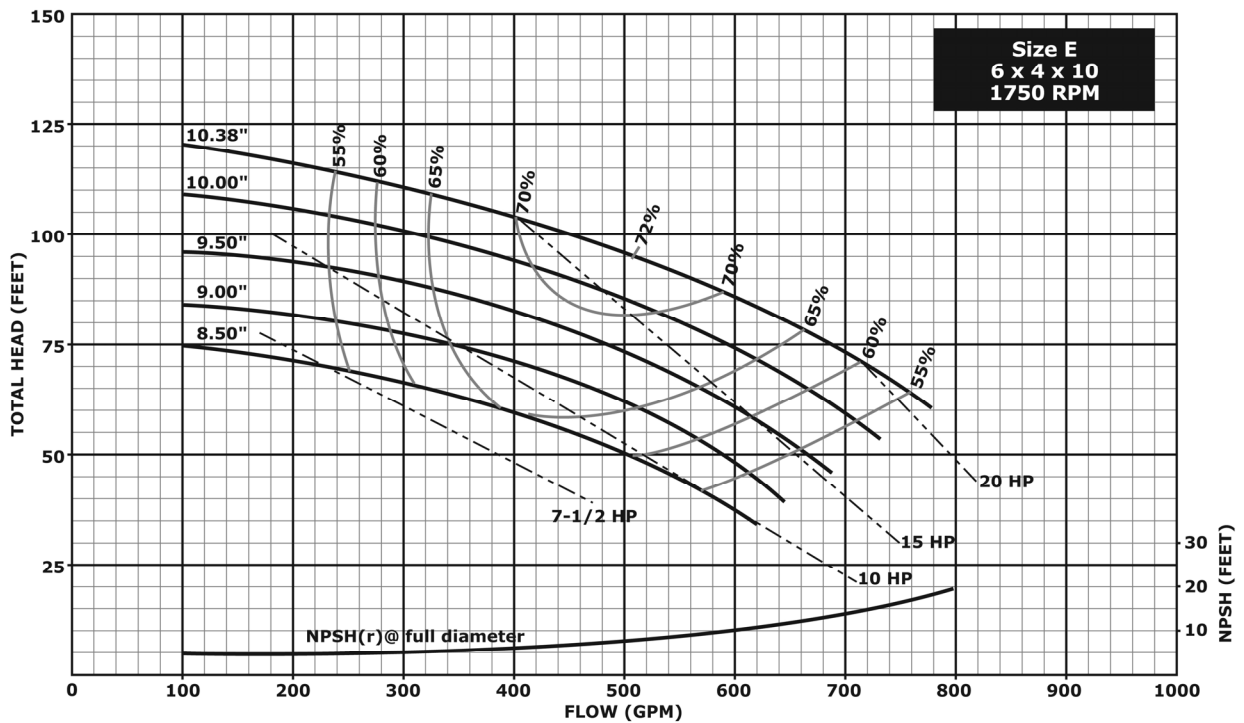
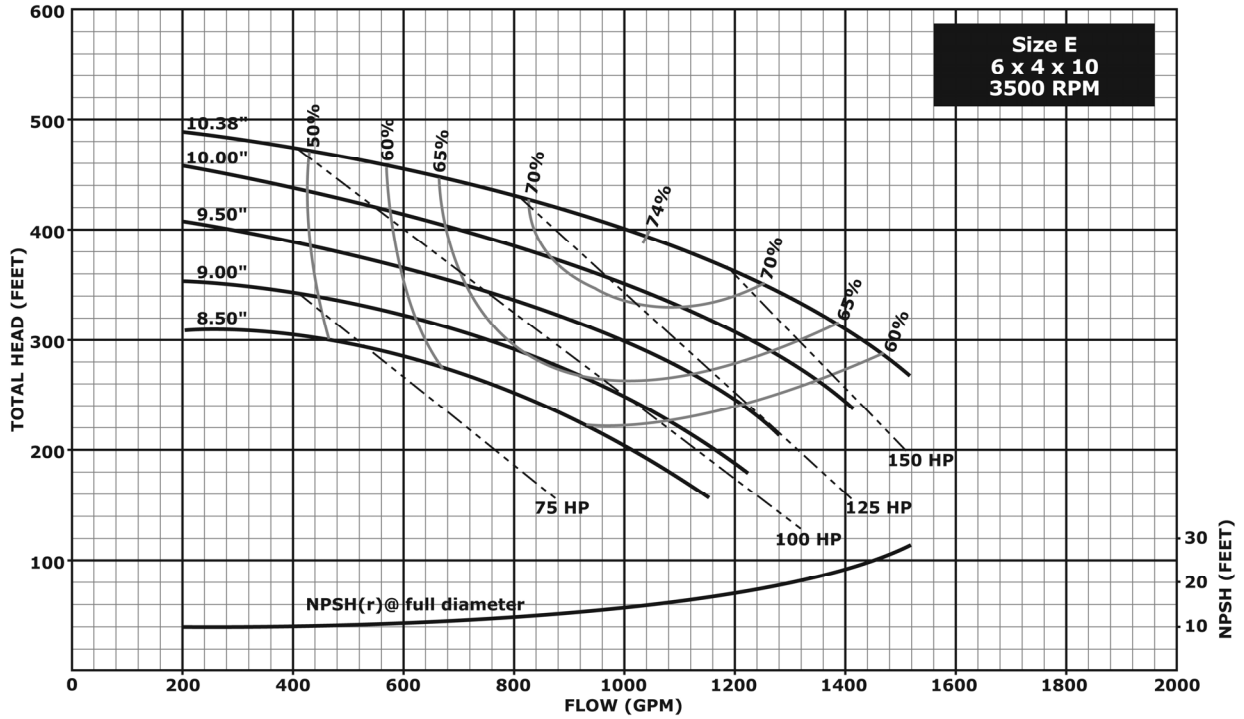

**Notes:**

1. Above curves show efficiency, flow and NPSHR performance on water at ambient temperature and atmospheric pressure.
2. For multi-stage performance, multiply head and power by the number of stages.
3. Size E available up to 8 stages at 1,750 RPM operating speed and up to 4 stages at 3,500 RPM operating speed.

**4.0 Casing Orientation and Maximum Allowable Flange Loading**

The flange positions shown are as viewed from shaft (drive) end of pump. The standard (default) flange position is C-2, with the suction facing the right (3 o'clock) position and discharge flanges in the top (12 o'clock) position with clockwise (CW) shaft rotation. Any other orientation must be specified when ordering. A minimum of four (4) stages are required for flanges to align the same position (i.e., A-1, B-2 or C-3).

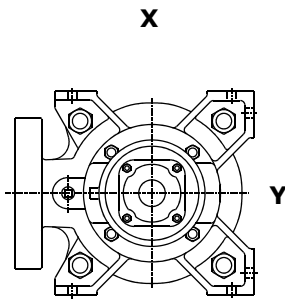

**Side Connection**  
Suction Position A  
Discharge Position 1

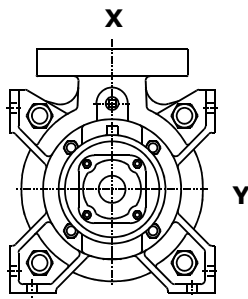

**Top Connection**  
Suction Position B  
Discharge Position 2

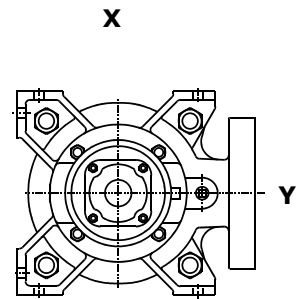

**Side Connection**  
Suction Position C  
Discharge Position 3

The maximum allowed forces and moments on the flanges will vary as a function of their orientation. The actual forces (F) and moments (M) for the flange positions are as shown in the table below, with the units of pounds (lbs) used for forces and foot-pounds (ft-lbs) for moments.

Maximum Allowable Flange Loading												
Size	Side Connection						Top Connection					
	F <sub>x</sub>	F <sub>y</sub>	F <sub>z</sub>	M <sub>x</sub>	M <sub>y</sub>	M <sub>z</sub>	F <sub>x</sub>	F <sub>y</sub>	F <sub>z</sub>	M <sub>x</sub>	M <sub>y</sub>	M <sub>z</sub>
A, B	256	555	567	643	839	370	710	232	732	552	839	266
C	266	573	595	746	988	414	710	244	778	649	988	311
D	399	822	827	1,290	1,599	801	1,130	352	997	1,082	1,599	565
E	599	1,228	1,281	2,361	3,003	1,411	1,673	530	1,575	2,007	3,003	1,011

**4.1 Standard Seal Flush Plan**

The standard seal flush plans provided with the optional outboard mechanical seal are shown below.

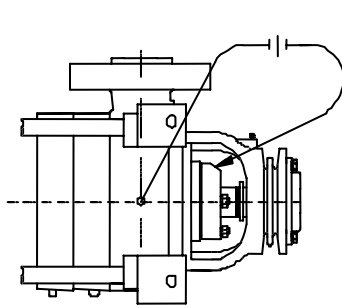

**Plan 11**  
Recirculation From Discharge Point to Seal

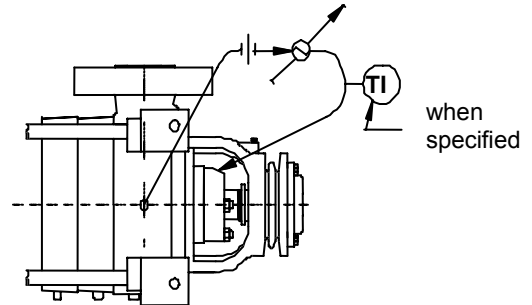

**Plan 21**  
Recirculation From Discharge Point Thru a TI and Heat Exchanger to Seal

**Inboard Stuffing Box Dimensions - Pumps With Outboard (Discharge) Sleeve Bearing**

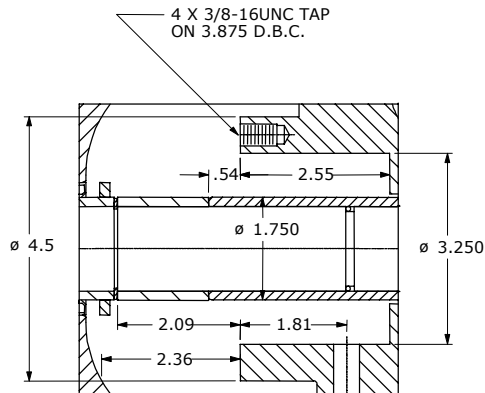

**Suction - Size A and B**

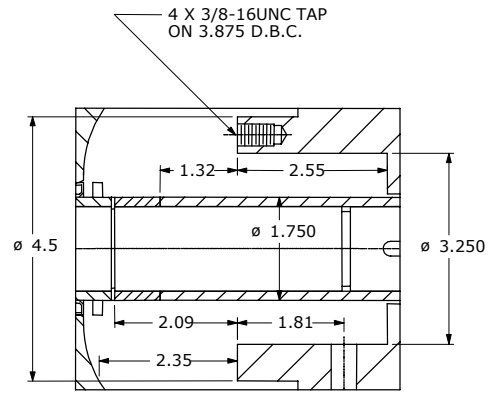

**Suction - Size C**

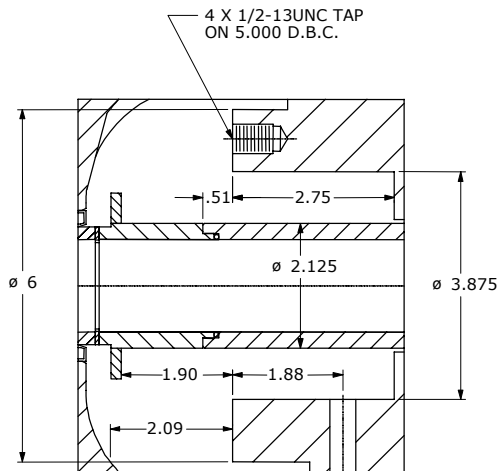

**Suction - Size D**

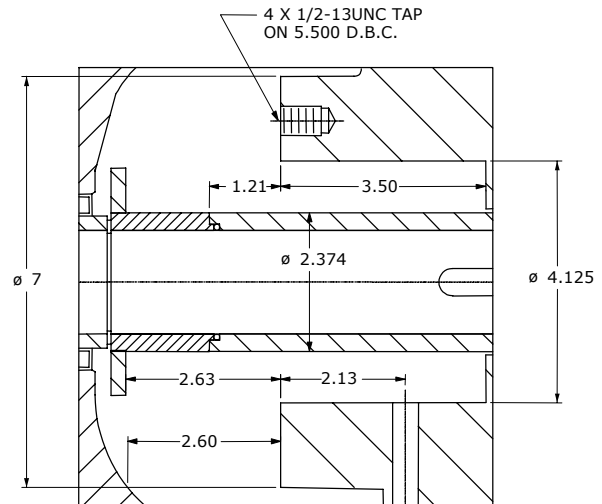

**Suction - Size E**



1. All dimensions in inches.
2. All tolerances are +/- 0.125 inch.
3. Not valid for construction unless certified.

**Inboard (Suction) End Stuffing Box Dimensions**

**Inboard and Outboard (Discharge) Stuffing Box Dimensions**

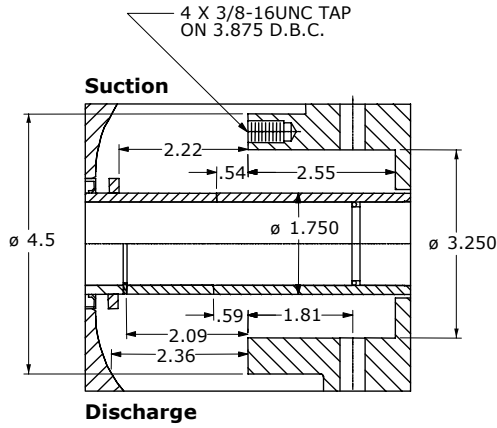

**Size A and B**

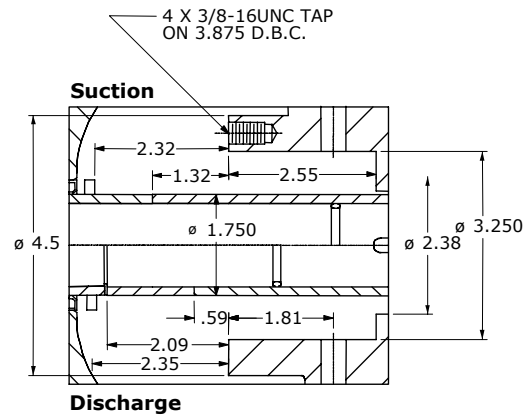

**Size C**

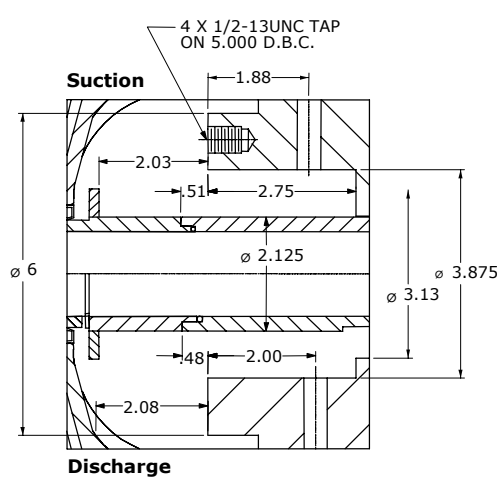

**Size D**

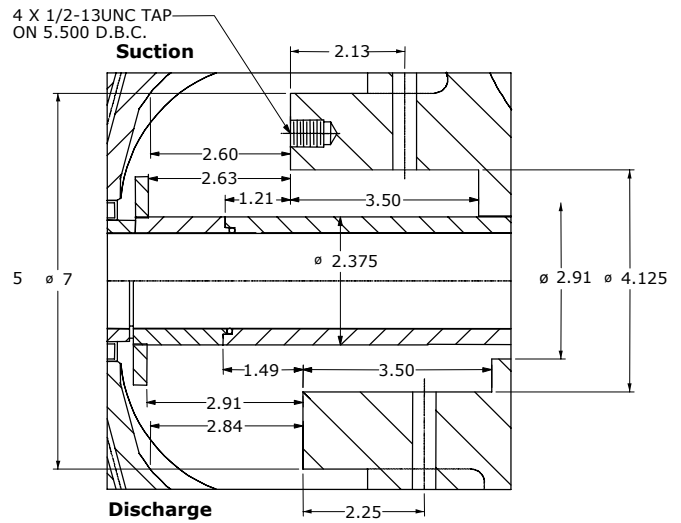

**Size E**



1. All dimensions in inches.
2. All tolerances are +/- 0.125 inch.
3. Not valid for construction unless certified.

**Inboard and Outboard  
Stuffing Box Dimensions**

**Bare Pump Dimensions**

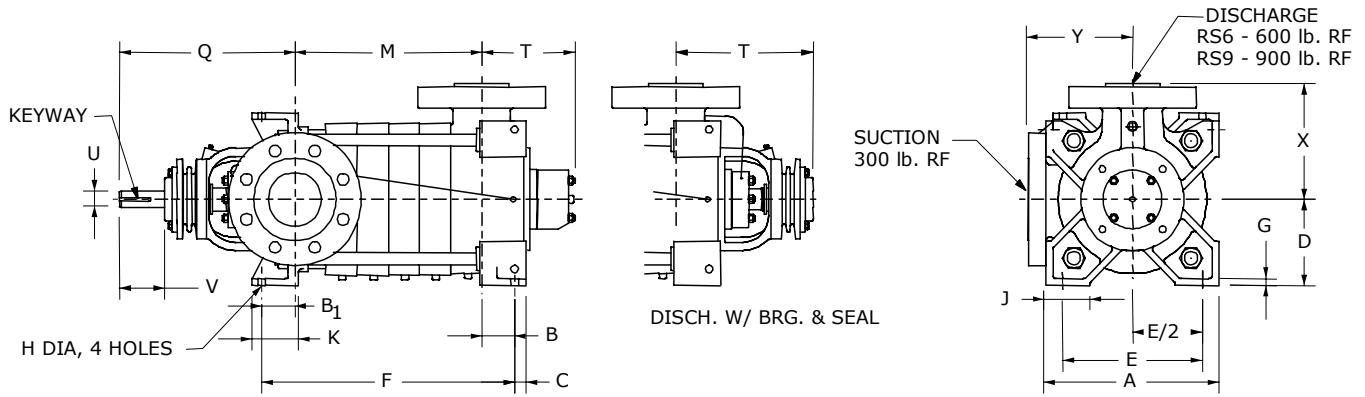

Size	Suction	Discharge	A	B	B1	C	D	E	Keyway
A & B	3	2	11.50	1.88	1.88	0.88	5.75	9.00	0.250 x 0.125 x 2.25
C	4	2 1/2	13.00	2.50	2.50	1.00	6.50	10.50	0.250 x 0.125 x 2.25
D	6	3	16.50	1.50	0.00	1.00	8.25	12.00	0.375 x 0.188 x 2.81
E	6	4	19.75	1.50	1.50	1.13	9.88	14.50	0.375 x 0.188 x 3.31

Size	G	J	K	Q	T			U	V		X	Y
					Slv Brg	Grease	Oil		Grease	Oil		
A & B	0.50	2.63	3.00	12.96	6.50	9.90	14.44	1.25	3.50	2.75	8.00	7.25
C	0.50	3.31	3.50	13.24	7.00	10.34	14.87	1.25	3.40	2.65	8.75	7.88
D	0.83	3.88	2.87	14.48	7.25	10.42	14.84	1.50	4.60	3.76	11.0	10.38
E	0.88	4.38	3.00	17.83	9.25	13.13	17.59	1.62	6.00	5.17	13.0	12.19

Size	M Dimension for Number of Stages																	
	2	3	4	5	6	7	8	9	10	11	12	13	14	15	16	17	18	
A & B	6.10	8.27	10.43	12.59	14.76	16.92	19.08	21.25	23.41	25.57	27.73	29.90	32.06	34.22	36.38	38.54	40.70	
C	7.00	9.35	11.71	14.07	16.43	18.79	21.16	23.52	25.88	28.24	30.60	-	-	-	-	-	-	
D	8.96	12.23	15.49	18.76	22.02	25.29	26.56	31.82	35.09	-	-	-	-	-	-	-	-	
E	10.67	14.61	18.54	22.48	26.41	30.35	34.28	-	-	-	-	-	-	-	-	-	-	

Size	F Dimension for Number of Stages																	
	2	3	4	5	6	7	8	9	10	11	12	13	14	15	16	17	18	
A & B	9.85	12.02	14.18	16.34	18.51	20.67	22.83	25.00	27.16	29.32	31.48	33.65	35.81	37.97	40.13	42.29	44.45	
C	11.99	14.35	16.71	19.07	21.43	23.79	26.16	28.52	30.88	33.24	-	-	-	-	-	-	-	
D	10.46	13.72	16.99	20.26	23.52	26.79	30.06	33.32	36.59	-	-	-	-	-	-	-	-	
E	13.67	17.61	21.54	25.48	29.41	33.35	37.28	-	-	-	-	-	-	-	-	-	-	

	1. All dimensions in inches.	<b>Dwg: SPRS-1, Rev: 1</b>
	2. All tolerances are +/- 0.125 inch.	
	3. Not valid for construction unless certified.	

RS Sizes A & B with NEMA Motor Frames 182T thru 405T

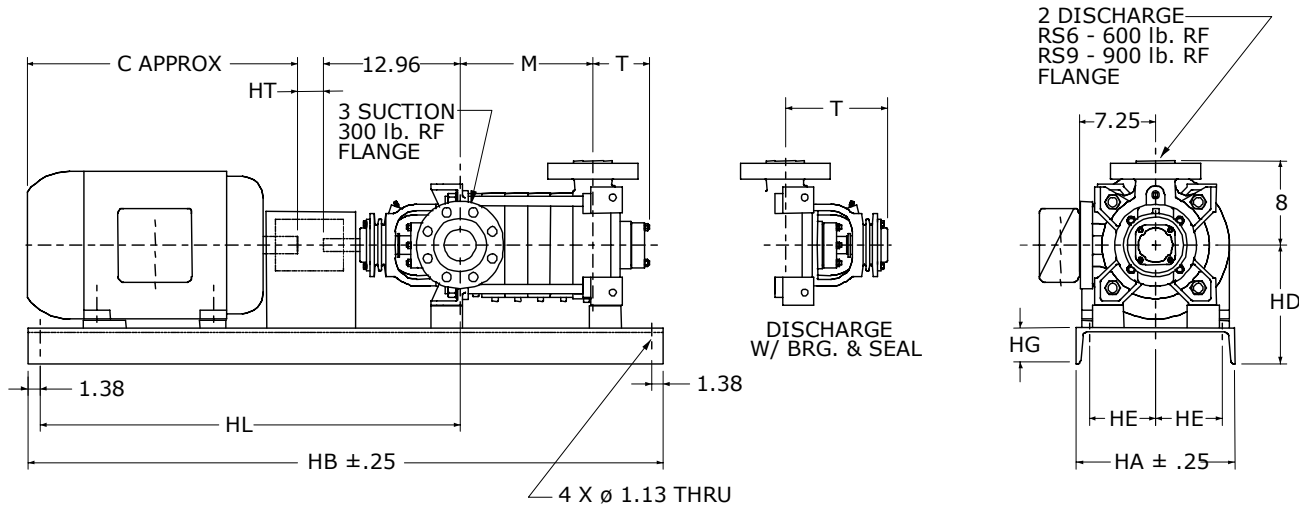

T			M Dimension for Number of Stages																
Slv Brg	Grease	Oil	2	3	4	5	6	7	8	9	10	11	12	13	14	15	16	17	18
6.50	10.00	14.50	6.10	8.27	10.43	12.59	14.76	16.92	19.08	21.25	23.41	25.57	27.73	29.90	32.06	34.22	36.38	38.54	40.70

Motor Frame	All Assemblies				Assemblies with STANDARD Shaft Couplings															
	C	HA	HD	HL	HB Dimension For Number Of Stages															
					2	3	4	5	6	7	8	9	10	11	12	13	14	15	16	17
182T / 184T	15.5	12.0	9.0	29.0	48	48	54	54	54	-	-	-	-	-	-	-	-	-	-	-
213T / 215T	20.0	12.0	9.8	30.5	52	52	52	58	58	58	64	64	64	70	70	70	-	-	-	-
254T / 256T	24.5	15.0	10.3	35.8	52	52	62	62	62	62	70	70	70	70	78	78	78	78	86	86
284T / 286T & TS	27.0	15.0	11.3	37.4	54	54	64	64	64	64	72	72	72	72	80	80	80	80	88	88
324T / 326T & TS	31.5	18.0	12.5	41.3	64	64	64	64	72	72	72	74	74	74	84	84	84	84	90	90
364T / 365T & TS	33.5	18.0	13.5	43.9	-	-	72	72	72	72	78	78	78	84	84	84	84	84	92	92
404T / 405T & TS	37.0	18.0	15.0	47.6	-	-	-	-	74	74	80	80	80	86	86	86	90	90	96	96

Motor Frame	All Assemblies				Assemblies with SPACER Shaft Couplings															
	HE	HG	HL	HT	HB Dimension for Number of Stages															
					2	3	4	5	6	7	8	9	10	11	12	13	14	15	16	17
182T / 184T	4.5	3.0	33.0	5.00	48	48	56	56	56	-	-	-	-	-	-	-	-	-	-	-
213T / 215T	4.5	3.0	36.5	5.00	56	56	56	62	62	62	68	68	68	74	74	74	-	-	-	-
254T / 256T	6.0	3.4	41.8	5.00	58	58	64	64	64	70	70	76	76	76	84	84	84	84	90	
284T / 286T & TS	6.0	3.4	43.4	5.00	64	64	64	64	72	72	72	78	78	78	86	86	86	86	92	92
324T / 326T & TS	7.5	4.0	45.3	5.00	66	66	66	66	74	74	74	80	80	80	88	88	88	88	94	94
364T / 365T & TS	7.5	4.0	47.9	5.00	-	-	70	70	76	76	76	82	82	82	90	90	90	90	96	96
404TS / 405TS	7.5	4.0	52.0	7.25	-	-	-	-	80	80	80	86	86	86	94	94	94	94	100	100
404T / 405T	7.5	4.0	53.4	7.25	-	-	-	-	82	82	82	90	90	90	98	98	98	98	104	104

	1. All dimensions in inches.	<p>Dwg: SP-RSA/B-1, Rev: 1</p>
	2. All tolerances +/- 0.125 inch.	
	3. Not valid for construction unless certified.	



Sizes A & B with NEMA Motor Frames 444TS thru 449T

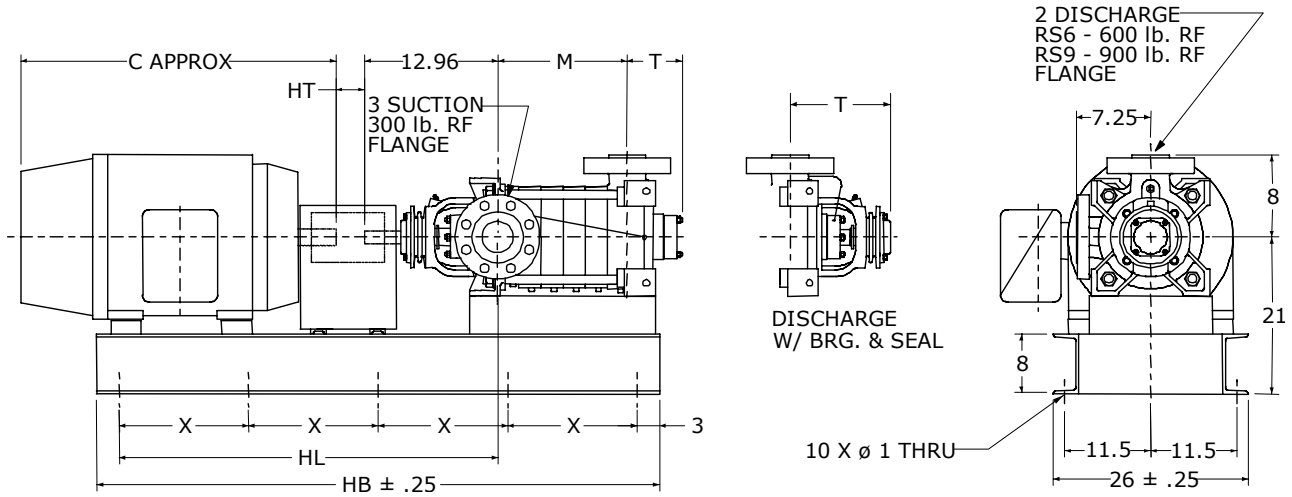

T			M Dimension for Number of Stages													
Slv Brg	Grease	Oil	5	6	7	8	9	10	11	12	13	14	15	16	17	18
6.5	10.0	14.5	12.59	14.76	16.92	19.08	21.25	23.41	25.57	27.73	29.90	32.06	34.22	36.38	38.54	40.70

Motor Frame	Assemblies with STANDARD Shaft Couplings																	
	C	HL	X	HB Dimension For Number Of Stages														
				5	6	7	8	9	10	11	12	13	14	15	16	17	18	
444T / 445T & TS	40.0	50.0	19.5	-	-	-	84	84	84	84	-	-	-	-	-	-	-	
444T / 445T & TS	40.0	50.0	22.0	-	-	-	-	-	-	-	94	94	94	94	-	-	-	
444T / 445T & TS	40.0	50.0	23.5	-	-	-	-	-	-	-	-	-	-	-	100	100	100	
447T & TS	49.0	57.1	23.5	-	-	-	-	-	-	-	-	-	100	100	100	-	-	
447T & TS	49.0	57.1	25.0	-	-	-	-	-	-	-	-	-	-	-	-	106	106	106

Motor Frame	Assemblies with SPACER Couplings																	
	C	HL	HT	X	HB Dimension For Number Of Stages													
					5	6	7	8	9	10	11	12	13	14	15	16	17	18
444T / 445T & TS	40.0	58.0	7.25	21.5	-	-	-	92	92	92	92	-	-	-	-	-	-	
444T / 445T & TS	40.0	58.0	7.25	24.0	-	-	-	-	-	-	-	102	102	102	102	-	-	
444T / 445T & TS	40.0	58.0	7.25	25.5	-	-	-	-	-	-	-	-	-	-	108	108	108	
447T & TS	49.0	65.1	7.25	25.5	-	-	-	-	-	-	-	-	108	108	108	-	-	
447T & TS	49.0	65.1	7.25	25.5	-	-	-	-	-	-	-	-	-	-	-	114	114	114

	1. All dimensions in inches.	<b>Dwg: SP-RSA/B-2, Rev: 1</b>
	2. All tolerances are +/- 0.125 inch	
	3. Not valid for construction unless certified.	

**Size C with NEMA Motor Frames 182T thru 405T**

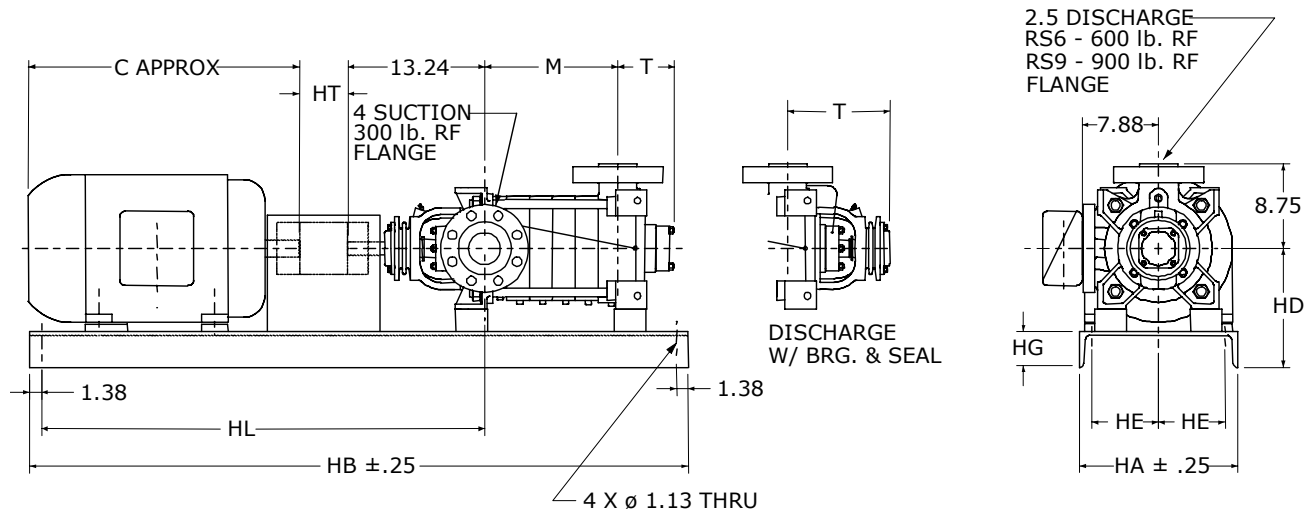

T			M Dimension for Number of Stages											
Slv Brg	Grease	Oil	2	3	4	5	6	7	8	9	10	11	12	
7.00	10.34	14.87	7.00	9.35	11.71	14.07	16.43	18.79	21.16	23.52	25.88	28.24	30.60	

Motor Frame	All Assemblies			Assemblies with STANDARD Shaft Couplings												
	C	HA	HD	HL	HB Dimension for Number of Stages											
					2	3	4	5	6	7	8	9	10	11	12	
182T / 184T	15.5	15.0	10.3	30.4	48	48	-	-	-	-	-	-	-	-	-	
213T / 215T	20.0	15.0	10.3	30.7	52	52	52	58	58	-	-	-	-	-	-	
254T / 256T	24.5	15.0	10.3	36.1	52	58	58	58	68	68	68	68	73	-	-	
284T / 286T & TS	27.0	15.0	11.3	37.6	58	58	58	68	68	68	68	76	76	76	76	
324T / 326T & TS	31.5	18.0	12.5	41.6	59	59	68	68	72	72	72	80	80	80	80	
364T / 365T & TS	33.5	18.0	13.5	44.1	-	68	68	68	76	76	76	84	84	84	84	
404T / 405T & TS	37.0	18.0	15.0	48.1	-	68	68	76	76	76	76	90	90	90	90	

Motor Frame	All Assys.		Assemblies with SPACER Shaft Couplings													
	HE	HG	HL	HT	HB Dimension for Number of Stages											
					2	3	4	5	6	7	8	9	10	11	12	
182T / 184T	6.0	3.4	34.4	5.00	52	52	-	-	-	-	-	-	-	-	-	
213T / 215T	6.0	3.4	36.7	5.00	58	58	58	64	64	64	-	-	-	-	-	
254T / 256T	6.0	3.4	40.1	5.00	58	64	64	64	72	72	72	72	78	-	-	
284T / 286T & TS	6.0	3.4	41.6	5.00	64	64	64	74	74	74	74	82	82	82	82	
324T / 326T & TS	7.5	4.0	45.6	5.00	64	64	74	74	76	76	84	84	84	86	86	
364T / 365T & TS	7.5	4.0	47.1	5.00	74	74	74	74	78	78	86	86	86	88	88	
404TS / 405TS	7.5	4.0	50.1	7.25	-	74	74	78	78	78	88	88	88	90	90	
404T / 405T	7.5	4.0	54.1	7.25	-	74	74	82	82	82	92	92	92	94	94	

	1. All dimensions in inches.	<b>Dwg: SP-RSC-1, Rev: 1</b>
	2. All tolerances are +/- 0.125 inch.	
	3. Not valid for construction unless certified.	

**Size C with NEMA Motor Frames 444T thru 449T**

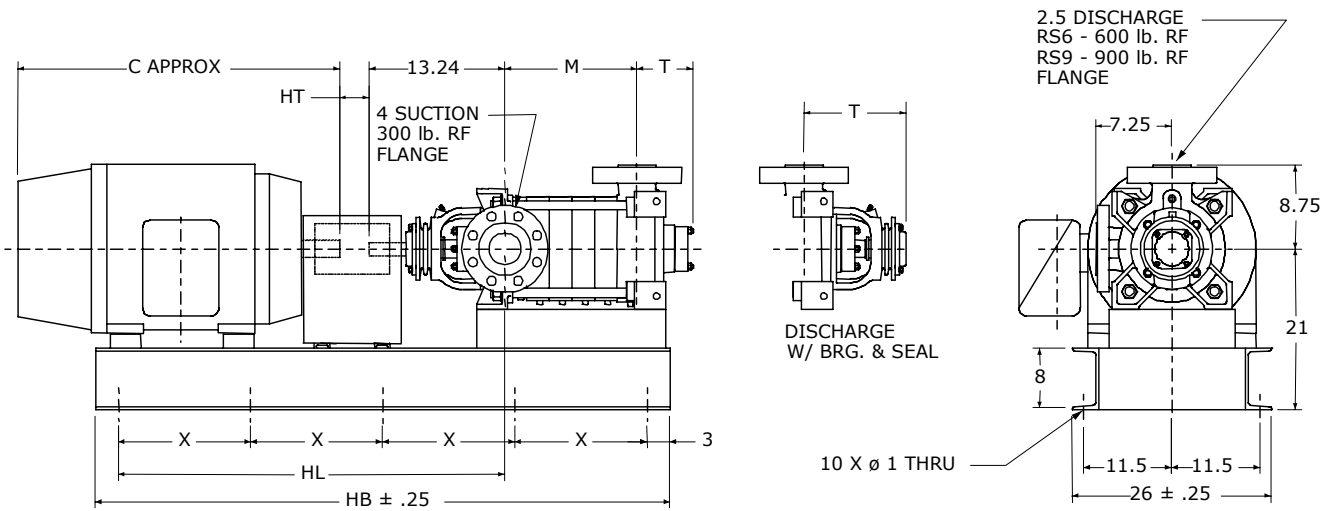

T			M Dimension for Number of Stages										
Slv Brg	Grease	Oil	2	3	4	5	6	7	8	9	10	11	12
7.00	10.34	14.87	7.0	9.4	11.7	14.1	16.4	18.8	21.2	23.5	25.9	28.2	30.6

Assemblies with STANDARD Shaft Couplings															
Motor Frame	C	HL	X	HB Dimension for Number of Stages											
				2	3	4	5	6	7	8	9	10	11	12	
444T / 445T & TS	40.0	50.4	17.25	-	-	75	75	-	-	-	-	-	-	-	
444T / 445T & TS,	40.0	50.4	19.50	-	-	-	-	84	84	84	84	-	-	-	
447T & TS / 449TS	50.0	57.4	20.50	-	-	-	-	88	88	88	-	-	-	-	
447T & TS / 449TS	50.0	57.4	22.25	-	-	-	-	-	-	-	95	95	95	95	
449T	54.0	62.4	21.75	-	-	-	-	93	93	93	-	-	-	-	
449T	54.0	62.4	23.50	-	-	-	-	-	-	-	100	100	100	100	

Assemblies with SPACER Shaft Couplings														
Motor Frame	C	HL	HT	X	HB Dimension for Number of Stages									
					2	3	4	5	6	7	8	9	10	11
444T / 445 T & TS	40.0	57.4	7.25	19.0	-	-	82	82	-	-	-	-	-	-
444T / 445 T & TS	40.0	56.4	7.25	21.0	-	-	-	-	90	90	90	90	-	-
447T & TS / 449TS	50.0	63.4	7.25	22.0	-	-	-	-	94	94	94	-	-	-
447T & TS / 449TS	50.0	62.4	7.25	23.5	-	-	-	-	-	-	100	100	100	100
449T	54.0	67.4	7.25	23.0	-	-	-	-	98	98	98	-	-	-
449T	54.0	68.4	7.25	25.0	-	-	-	-	-	-	106	106	106	106

	<ol style="list-style-type: none"> <li>All dimensions in inches.</li> <li>All tolerances are +/- 0.125 inch.</li> <li>Not valid for construction unless certified.</li> </ol>	<b>Dwg: SP-RSC-2, Rev: 2</b>
--	---	------------------------------

**Size D Pump with NEMA Motor Frames 213T thru 405T**

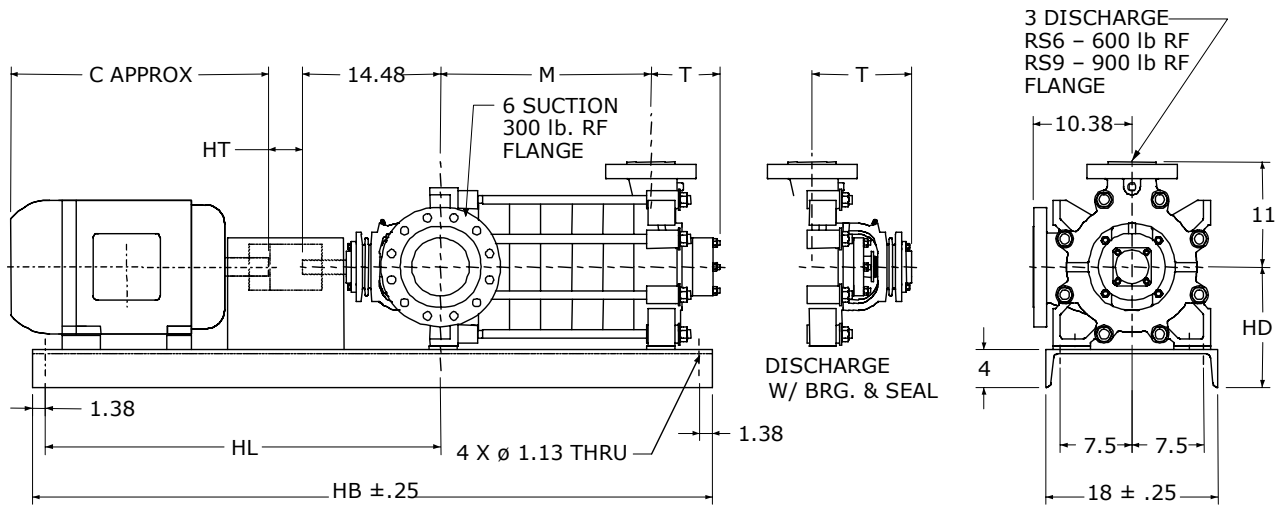

T			M Dimension for Number of Stages									
Slv Brg	Grease	Oil	1	2	3	4	5	6	7	8	9	10
7.25	10.42	14.84	8.96	12.23	15.49	18.76	22.02	25.29	26.56	31.82	35.09	8.96

Assemblies with STANDARD Shaft Couplings													
Motor Frame	C	HD	HL	HB Dimension for Number of Stages									
				2	3	4	5	6	7	8	9	10	
213T, 215T	20.0	12.63	29.63	48	55	-	-	-	-	-	-	-	
254T, 256T	24.5	12.63	35.63	58	58	58	-	-	-	-	-	-	
284T / 286 T & TS	27.0	12.63	38.12	58	62	62	68	68	-	-	-	-	
324T / 326 T & TS	31.5	12.63	40.63	58	62	70	70	70	78	78	84	84	
364T / 365 T & TS	33.5	13.50	42.63	62	62	70	70	80	80	80	86	86	
404T / 405T & TS	37.0	15.00	46.63	68	68	74	74	82	82	90	90	90	

Assemblies with SPACER Shaft Couplings														
Motor Frame	C	HD	HL	HT	HB Dimension for Number of Stages									
					2	3	4	5	6	7	8	9	10	
213T, 215T	20.0	12.63	35.63	5.00	54	62	-	-	-	-	-	-	-	
254T, 256T	24.5	12.63	41.63	5.00	64	64	64	-	-	-	-	-	-	
284T / 286 T & TS	27.0	12.63	44.12	5.00	64	68	68	74	74	-	-	-	-	
324T / 326 T & TS	31.5	12.63	46.63	5.00	64	68	76	76	76	84	84	90	90	
364T / 365 T & TS	33.5	13.50	46.63	5.00	68	68	76	76	86	86	86	92	92	
404TS / 405TS	37.0	15.00	50.75	7.00	72	72	78	78	86	86	94	94	94	
405T / 405TS	40.0	15.00	54.75	7.00	76	76	82	82	90	90	98	98	98	

	1. All dimensions in inches.	<b>Dwg: SP-RSD-1, Rev: 1</b>
	2. All tolerances are +/- 0.125 inch	
	3. Not valid for construction unless certified.	

Size D with NEMA Motor Frames 444T thru 449TS

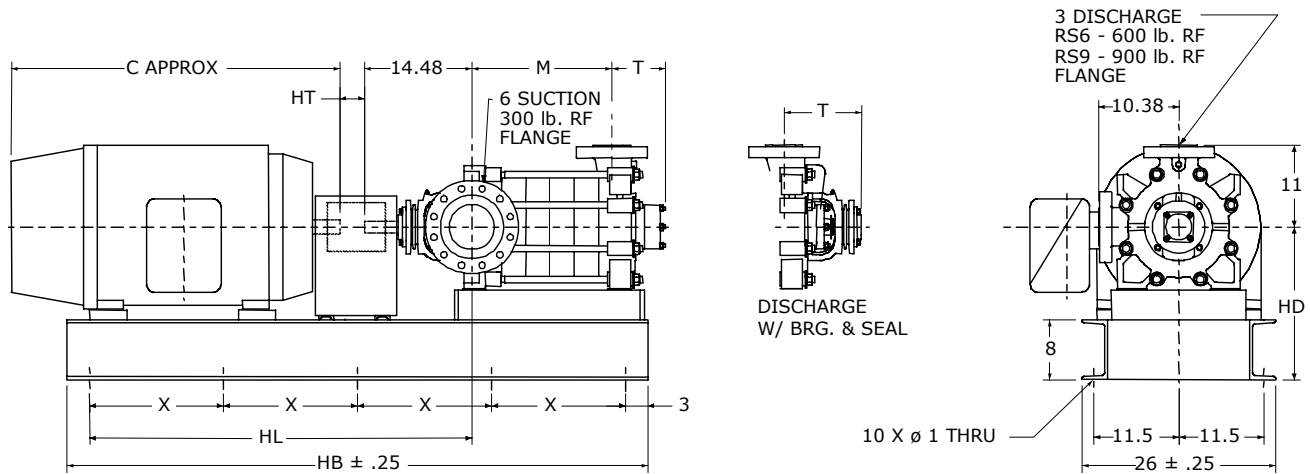

T			M Dimension for Number of Stages									
Slv Brg	Grease	Oil	2	3	4	5	6	7	8	9	10	
7.25	10.42	14.84	8.96	12.23	15.49	18.76	22.02	25.29	26.56	31.82	35.09	

Assemblies with STANDARD Shaft Coupling														
Motor Frame	C	HD	HL	X	HB Dimension For Number Of Stages									
					2	3	4	5	6	7	8	9	10	
444T / 445T & TS	40	20.5	51.4	18.0	78	78	78	78	-	-	-	-	-	
447TS	45	20.5	51.4	18.0	78	78	78	78	-	-	-	-	-	
449TS	50	21.0	59.1	21.0	90	90	90	90	90	-	-	-	-	
449TS	50	21.0	59.1	22.5	-	-	-	-	-	100	100	100		

Assemblies with SPACER Shaft Couplings															
Motor Frame	C	HD	HL	HT	X	HB Dimension For Number Of Stages									
						2	3	4	5	6	7	8	9	10	
444T / 445T & TS	40	20.5	59.4	7.25	20.0	86	86	86	86	-	-	-	-	-	
447TS	45	20.5	59.4	7.25	20.0	86	86	86	86	-	-	-	-	-	
449TS	50	21.0	67.1	7.25	23.0	98	98	98	98	98	-	-	-	-	
449TS	50	21.0	67.1	7.25	24.5	-	-	-	-	-	108	108	108		

	1. All dimensions in inches.	<b>Dwg: SPRSD-2, Rev. 1</b>
	2. All tolerances are +/- 0.125 inch.	
	3. Not valid for construction unless certified.	

**Size E with NEMA Motor Frames 254T thru 405T**

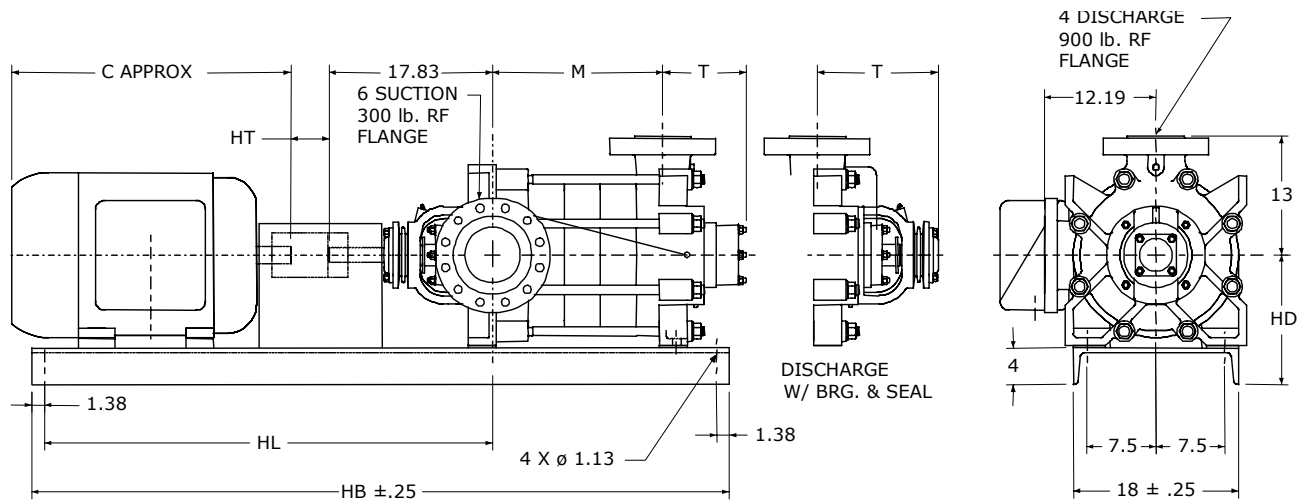

T		
Slv Brg	Grease	Oil
9.25	13.13	17.59

M Dimension for Number of Stages			
1	2	3	4
6.74	10.67	14.61	18.54

Assemblies with STANDARD Shaft Couplings										
Motor Frame	C	HD	HL	HB Dimension for Number of Stages						
				2	3	4	5	6	7	8
254T, 256T	24.5	14.25	38.88	60	-	-	-	-	-	-
284T, 286T	27.0	14.25	42.88	64	-	-	-	-	-	-
324T, 326T	31.5	14.25	44.88	68	68	72	76	-	-	-
364T, TS & 365T, TS	33.5	14.25	44.88	72	72	72	80	80	88	88
404T, TS & 405T, TS	40.0	14.63	48.88	-	76	76	84	84	92	92

Assemblies with SPACER Shaft Couplings											
Motor Frame	C	HD	HL	HT	HB Dimension for Number of Stages						
					2	3	4	5	6	7	8
254T, 256T	24.5	14.25	46.88	7.25	68	-	-	-	-	-	-
284T, 286T	27.0	14.25	48.88	7.25	70	-	-	-	-	-	-
324T, 326T	31.5	14.25	52.88	7.25	76	76	80	84	-	-	-
364T, TS & 365T, TS	33.5	14.25	52.88	7.25	80	80	80	88	88	96	96
404T, TS & 405T, TS	40.0	14.63	56.88	7.25	-	84	84	92	92	100	100

	1. All dimensions in inches.	<b>Dwg: SPRSE-1, Rev. 1</b>
	2. All tolerances are +/- 0.125 inch.	
	3. Not valid for construction unless certified.	

**Size E with NEMA Motor Frames 444T thru 449T**

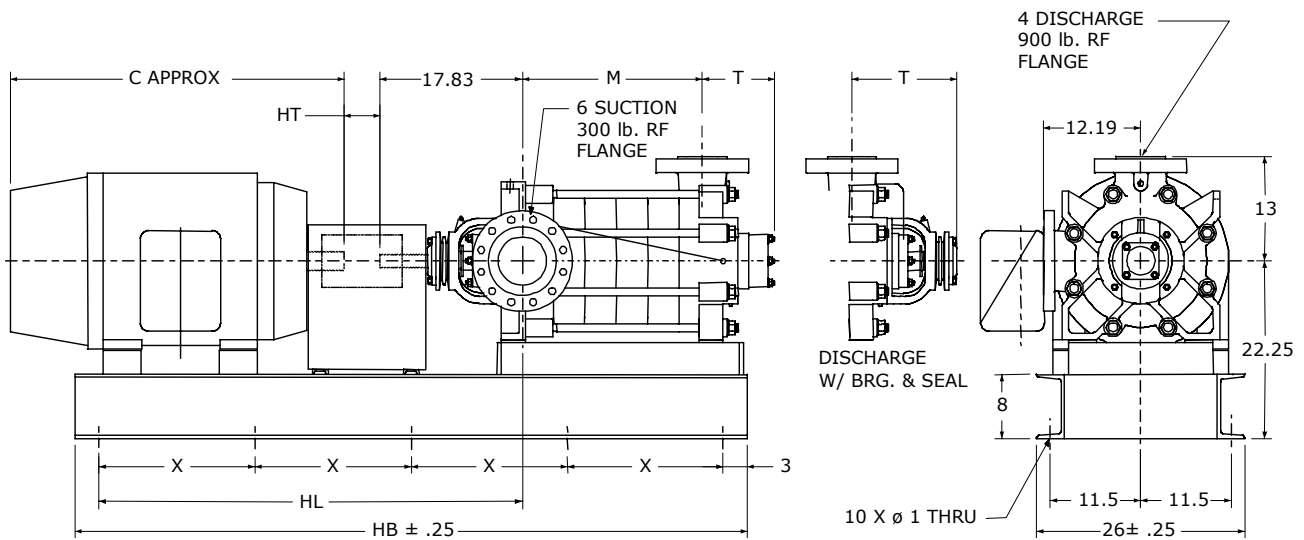

T			M Dimension for Number of Stages							
Slv Brg	Grease	Oil	1	2	3	4	5	6	7	8
9.75	13.13	17.59	6.74	10.67	14.61	18.54	22.48	26.41	30.35	34.28

Assemblies with STANDARD Shaft Couplings										
Motor Frame	C	HL	X	HB Dimension for Number of Stages						
				2	3	4	5	6	7	8
444T, TS & 445T, TS	40	52.88	19.5	-	84	84	84	-	-	-
444T, TS & 445T, TS	40	52.88	22.5	-	-	-	-	96	96	96
447T, TS	49	60.75	20.0	86	86	-	-	-	-	-
447T, TS	49	60.75	22.5	-	-	96	96	96	-	-
449T, TS	54	60.75	22.0	94	94	-	-	-	-	-
449T, TS	54	60.75	24.0	-	-	102	102	102	-	-

Assemblies with SPACER Shaft Couplings											
Motor Frame	C	HL	HT	X	HB Dimension for Number of Stages						
					2	3	4	5	6	7	8
444T, TS & 445T, TS	40	60.9	7.25	21.5	-	92	92	92	-	-	-
444T, TS & 445T, TS	40	60.9	7.25	24.5	-	-	-	-	104	104	104
447T, TS	49	66.8	7.25	21.5	92	92	-	-	-	-	-
447T, TS	49	66.8	7.25	24.0	-	-	102	102	102	-	-
449T, TS	54	72.8	7.25	23.5	100	100	-	-	-	-	-
449T, TS	54	72.8	7.25	25.5	-	-	108	108	108	-	-

	1. All dimensions in inches.	<b>Dwg: SPRSE-2, Rev. 1</b>
	2. All tolerances are +/- 0.125 inch.	
	3. Not valid for construction unless certified.	



**S**ince we built our first pumps in 1938, the Carver name has become synonymous with value. Today we are recognized as one of the world's leading centrifugal pump companies, building pumps to the most demanding engineering specifications and military standards in the world.

Our company is located in Muscatine, Iowa, 25 miles southwest of the Quad Cities area. Our operations there include some of the most modern manufacturing equipment and pump development software available, and we are committed to the highest quality possible in our products and our people. Along these lines, Carver was also one of the first American pump companies to attain ISO 9001 certification—the most recognized standard for quality in the world.

From an applications standpoint Carver has traditionally built pumps for water, oil, and chemicals for both the public and private sectors. Our product line includes both horizontal and vertical end suction, multistage, axial split case, self-priming, API, and solids-handling pumps that all carry the same Carver trademark: lasting value from solid, straightforward designs engineered to provide many years of service.

These pumps are also backed by unparalleled aftermarket support. Our network of stocking distributors, manufacturer's representatives and certified service centers throughout the world means that no matter where your pump may be installed, there are local sales and service people ready to support your aftermarket needs.



**Carver Pump Company**

2415 Park Avenue • Muscatine, IA 52761  
563.263.3410 • Fax: 563.262.0510

[www.carverpump.com](http://www.carverpump.com)